



LG-021

RU	Подставка для гипсокартона Руководство по эксплуатации и технике безопасности
GB	Drywall panel hoist Original instruction manual
PL	Podnośnik płyt gipsowych Instrukcja obsługi i bezpieczeństwa

Данное изображение предназначено для ознакомления. Конструкция и комплектация могут отличаться.

This image is for reference only. Design and equipment may vary.

Ten obraz ma charakter wyłącznie poglądowy. Wygląd i wyposażenie mogą się różnić.

PLASTERBOARD LIFT

To get the most out of your new plasterboard lift, please read through these instructions and the attached safety instructions before use.

Please also save the instructions in case you need to refer to them at a later date.

Using the plasterboard lift, one person can lift a covering board with a size of up to 122x488 cm without any additional help. The covering board can be lifted a maximum of 335 cm from the floor to flat ceilings, sloping walls or other walls when the tilt function is used.

The cradle of the plasterboard lift can be lowered to 120 cm from the floor so that it is easy to load a board onto it. The plasterboard lift can tolerate loads up to 68 kg.

These instructions describe how the plasterboard lift is assembled, used and dismantled for transport and storage. Please read these user and safety instructions carefully before using the plasterboard lift for the first time.

TECHNICAL DATA

Plasterboard size	Max. 122x488 cm
Max. Load	68 KG
Max. Lifting Height	330 CM
Loading Height	120 CM
Weight	39 KG

SPECIAL SAFETY INSTRUCTIONS

- ALWAYS read the instructions before use, and observe all warnings.
- ALWAYS inspect the plasterboard lift each day before use and pay particular attention to the condition of the wire.
- ALWAYS allow the plasterboard lift to reach room temperature before use. If you move the plasterboard lift from a cold room to a warm one, condensation may form, which may affect the function of the brake!
- Check before use that the brake drum is clean and dry.
- NEVER use the plasterboard lift unless both arms are secured with the lock tab.
- ALWAYS keep the work area free of obstructions.
- ALWAYS wear a helmet when using the plasterboard lift.
- ALWAYS be aware of obstructions above the plasterboard lift when lifting boards.
- NEVER use the plasterboard lift for lifting objects other than plasterboards and similar.
- NEVER lift more than one board at a time. Never lift more than 68 kg

Parts

The plasterboard lift is supplied in parts which must be assembled before use:

- Base
- Frame including hoist and 120 cm telescopic sections
- Cradle, without removable support arms
- Two support arms

Assembly instructions

1. Set the base up:
Place the base on the floor so that it rests on its wheels.

Press the lock ring down. Hold the lock ring down while you swing the two front legs out so that the lock ring engages with the hole at the bottom of the tube. (See figure 1).

To prevent the base rolling backwards while assembling it, flip the reverse brake down as shown.

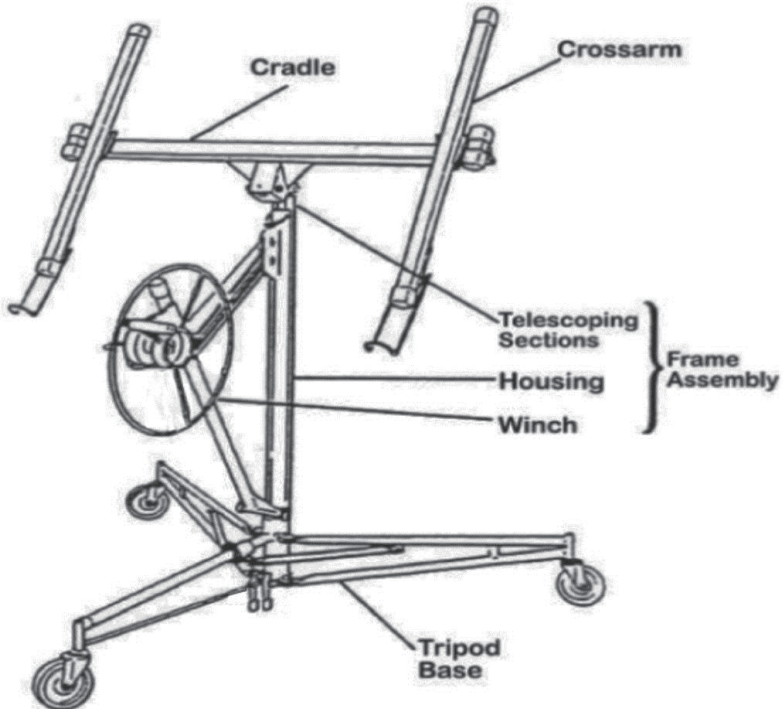
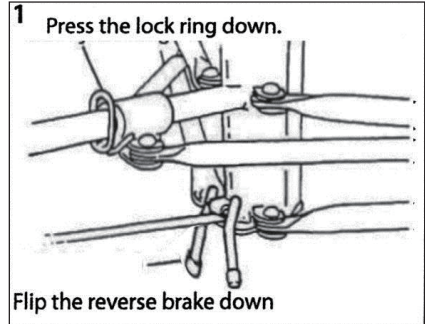

- Position the frame on the two "V" angles on the base and lower the frame around 2.5 cm until it sits firmly in the angles. Before continuing, make sure that the frame is pushed fully down and that it is secure in the angles.
- Attach the handle to the handwheel for the hoist. Tighten the nut and then loosen it slightly so that the handwheel rotates freely.
- Move the hoist to the working position: Hold the handwheel and brake lever as shown in figure 2.

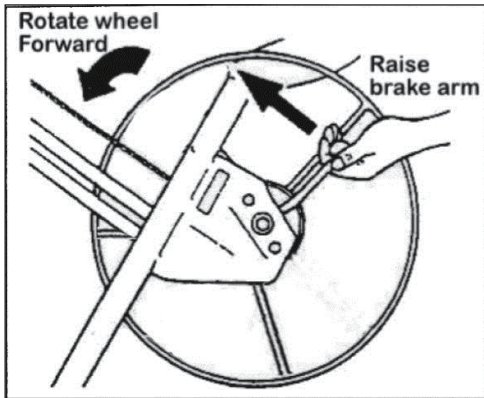

Turn the handwheel slightly forward while lifting the brake lever to release the brake.

Lift the brake lever up fully. Take hold of the strut by the hoist and hold the brake lever with your thumb. (See figure 3).

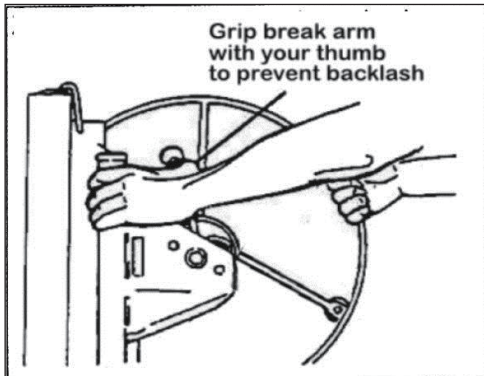

Place your right hand at the top of the frame. Continue to hold the brake lever to avoid the wire retracting and pull the hoist towards you. (See figure 4).

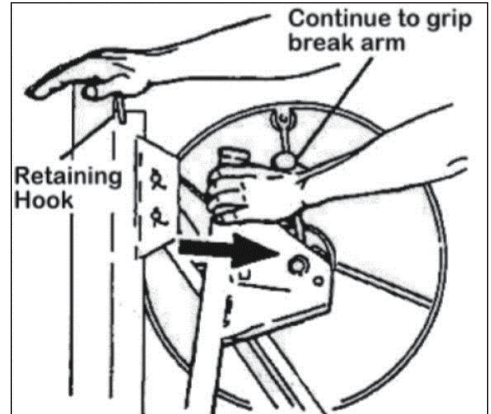

Once the hoist has been drawn completely out (away from the frame), release the brake lever and flip the lock hook away so that it no longer holds the telescopic sections inside the frame.

- Press the hoist gently back towards the frame. This allows the lock arm to engage with the hoist and keep it fully out. (See figure 5).

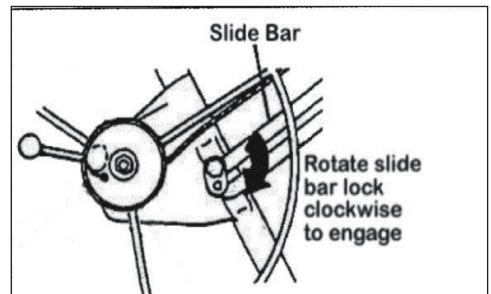

IMPORTANT! Before proceeding, make sure that the lock arm has engaged correctly, i.e. has turned as far clockwise as possible.

WARNING! In order to avoid an accident, the lock arm must be fully engaged when the hoist is pulled out.

6. Attach the cradle to the frame (figure 6):

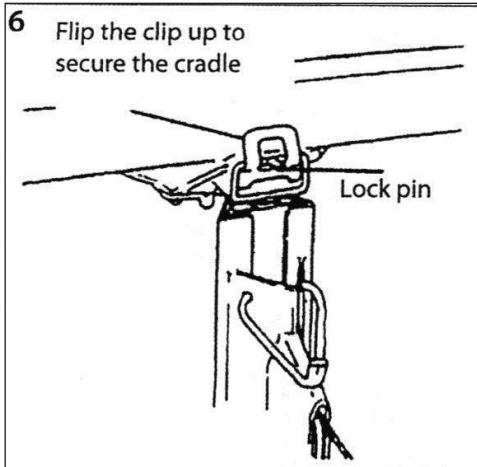

- a. Insert the cradle strut into the opening at the top of the frame.
 - b. Secure the cradle to the frame by pressing the clip up over the lock pin so that it clamps the cradle tight.
7. Attach the support arms to the cradle:

NOTE! The support arms are identical.

- a. Push the tapered plates on the support arms into the tapered sockets on the cradle. (See figure 7).

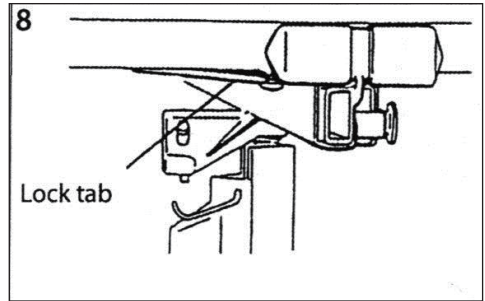
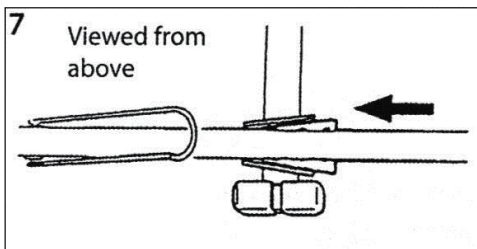

- b. Push both support arms into the sockets until the lock tab at the bottom of each support arm engages. (See figure 8).

Operating parts

Lock ring

Press the lock ring down to release the two front legs so that they can be rotated out to the working position or in to the storage position. A spring-loaded tab engages with a hole at the bottom of the tube to lock the legs in position.

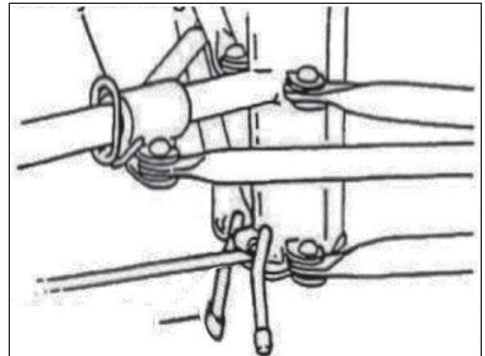

Reverse brake

Flip the reverse brake down to prevent the base from rolling backwards or flip it up to allow it to move freely.

Outriggers

The outriggers on the support arms can be pulled out so that the plasterboard lift can support a larger covering board.

Pull the lock pin with your right hand and pull the outrigger out using your left hand. The lock pin can secure the outrigger in one of three positions: Folded in or extended by 53 or 84 cm.

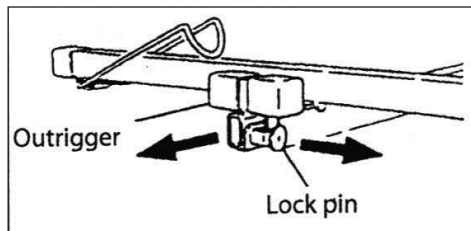

IMPORTANT! Never load a covering board on the cradle and never use the lift if the lock pins have not engaged in one of these three positions or if the outriggers have been pulled out more than 84 cm.

To avoid damaging the outriggers push them in fully before transporting or storing the plasterboard lift.

Support hooks for boards

Flip the support hooks on each support arm out to support the covering board when placed on the cradle or when the cradle is tilted.

In order to avoid damaging the support hooks, push them in fully before transporting or storing the plasterboard lift.

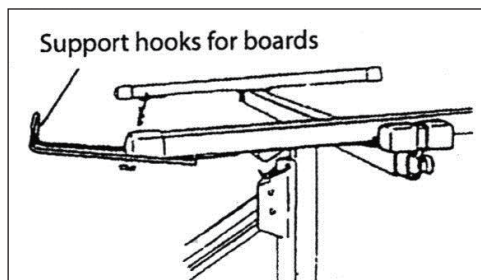

Lock arm

The lock arm keeps the hoist in the working position (fully extended).

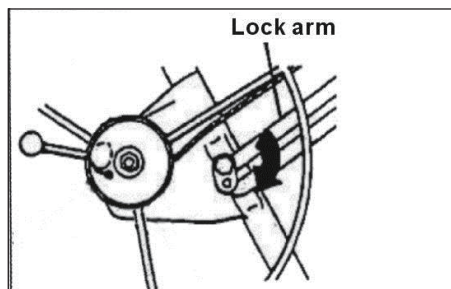

To fold the hoist in towards the frame (when dismantling or for transport), turn the hoist anticlockwise while lifting the lock arm. When you reassemble the plasterboard lift, pull the hoist out fully and then push it back in slightly so that it automatically engages with the lock arm.

Never tighten the nut on the lock arm, as you will then not be able to fold the hoist for transport and storage.

Clip for tilt

Flip the clip out and down to tilt the cradle (to apply covering boards or lifting covering boards for sloping walls or ceilings) or to remove the cradle. You can secure the cradle on the frame without tilt by flipping the clip up so that it engages with the lock pin on the cradle.

Note! When the cradle is in the horizontal position (not tilted), the cradle can tilt up to +/- 10 degrees.

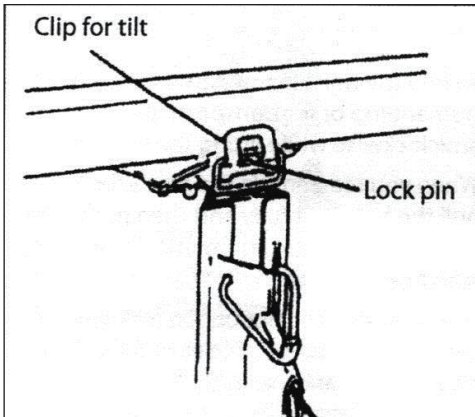

Handwheel, handle and strut

When turning the hoist's handwheel, the wire will wind in or out and thus raise or lower the cradle.

Hold the strut to provide resistance as you turn the handwheel.

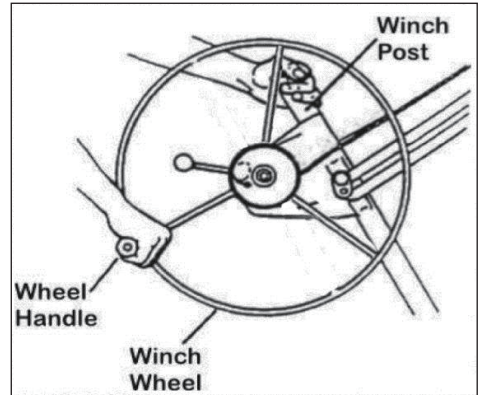

Lock hook

The lock hook secures the telescopic sections inside the frame for transport and storage.

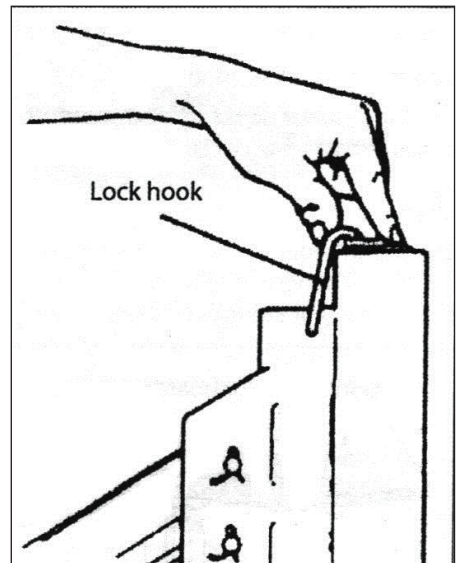

Brake lever

A spring-loaded brake holds the cradle securely at the required height by locking the hoist's handwheel. When lowering the cradle, control the rotation of the hoist by holding the handwheel as you carefully lift the brake lever to release the brake.

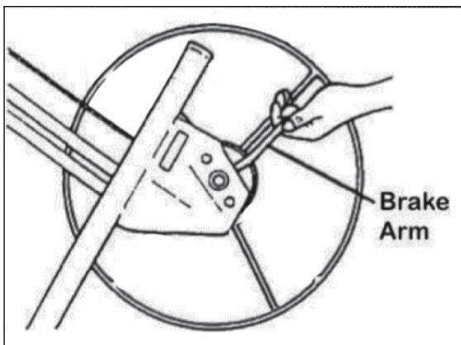

Use

IMPORTANT! Read the section 'Special safety instructions' before using the plasterboard lift.

WARNING! ALWAYS wear a helmet when using the plasterboard lift.

WARNING! Only use the plasterboard lift for lifting covering boards. Only lift ONE board at a time!

Safety check before use

Each working day, perform the following checks before using the plasterboard lift:

- Inspect the plasterboard lift thoroughly for wear and tear. Pay particular attention to the condition of the wire.
- Make sure the plasterboard lift has reached room temperature before use.
- Check that the brake drum is clean and dry.

Loading a covering board

1. Flip the reverse brake down so that the plasterboard lift does not roll backwards.
2. Flip the support hooks on the support arms out. Make sure that the cradle is turned so that the support hooks are furthest away from the handwheel.
3. Pull the outriggers on the support arms out so that they can provide optimum support for the covering boards.

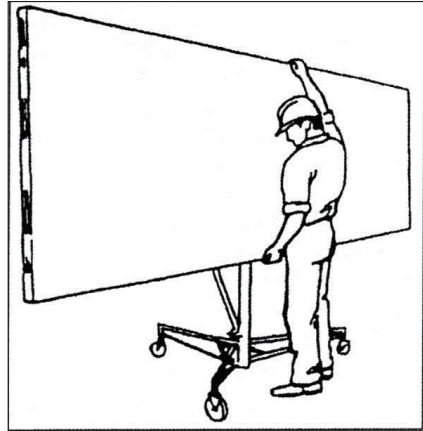

4. Release the clip so that the cradle can tilt.
5. Hold the covering board against the tilted cradle with the outer side facing down. Lower the covering board onto the support hooks and lay it carefully against the support arms.
6. If the covering board is to be mounted on a flat ceiling, tip the cradle up to the horizontal position and tighten the clip so that the cradle does not tilt. If the covering board is to be installed on a sloping wall or a sloping ceiling, the cradle should remain tilted.
7. Lift the reverse brake on the base and carefully roll the plasterboard lift to the spot where the covering board is to be installed.

Lifting the covering board

IMPORTANT! Always flip the reverse brake down before lifting the covering board up towards a sloped wall or other wall.

Turn the handwheel round in the direction shown (hold the strut to provide resistance) until the covering board is at the required height.

The brake is spring-loaded and automatically holds the cradle securely at the required height when you stop turning the handwheel.

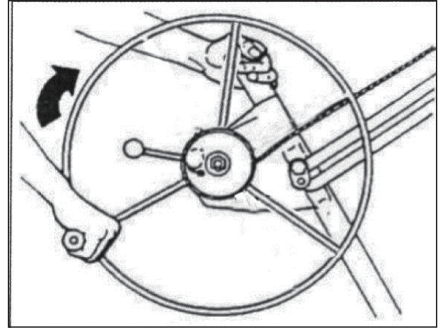

Lowering the covering board

1. Take hold of the handwheel handle with your right hand so that you can control the rotation of the hoist.
2. Keep tight hold of it. Carefully release the brake with your left hand and turn the handwheel slowly back to lower the cradle to the required height.

WARNING! To avoid accidents, be aware of any obstructions above the lift when lifting boards.

CAUTION! The cradle drops quickly once the brake lever is released. So grip the handle on the handwheel firmly with your right hand BEFORE releasing the brake!

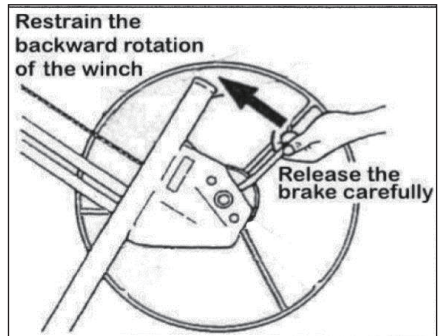
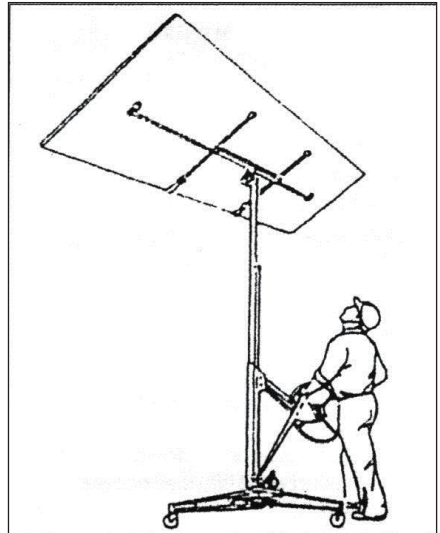

Dismantling

How to dismantle the plasterboard lift for transport and storage:

1. Lower the cradle fully.
2. Push the outriggers in fully until they engage. Fold the support hooks in.
3. Detach the support arms from the cradle by pressing the lock tab at the bottom and pulling the support arms out of the tapered sockets.

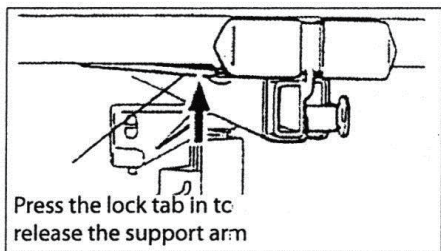

4. Release the clip for the tilt function. Lift the cradle about 7.5 cm until you can remove it from the frame.
5. Turn the handle forward one full revolution as shown. This lifts the inner telescopic section.

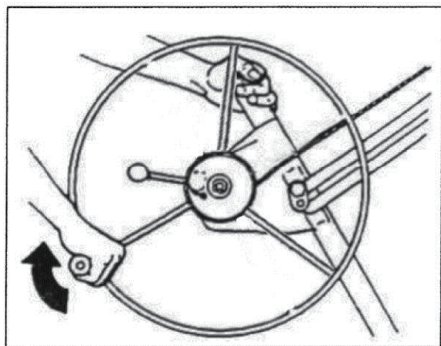

6. Release the hoist by lifting the lock arm with your left hand and turning the lock arm's lock anticlockwise with your right hand.

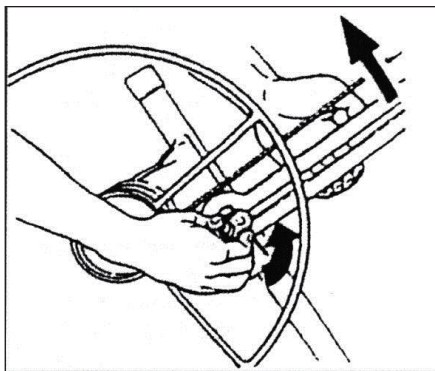

7. Hold the lock arm's lock in the released position (step 6), and push the telescopic sections down into the frame using your left hand. The hoist is now pulled towards the frame.
8. Lower the telescopic sections fully. Flip the lock hook up and turn the telescopic sections up slightly until they are held by the lock hook.
9. Hold the lock hook in this position with your left hand and turn the handwheel forward with your right hand. The hoist is pressed forward towards the frame. When the lock arm touches the frame, tighten the wire by turning the handwheel slightly (just enough to hold the hoist in that position).

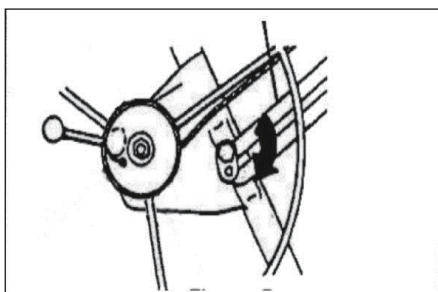

10. Carefully lift the frame and hoist around 2.5 cm to release it from the base.
11. Fold the frame up by pressing the lock ring down and pressing the front legs in until they engage in the folded position.

Maintenance

- Inspect the wire before each work day. If it shows signs of wear, replace it immediately (see the instructions which accompany the new wire).
- Lubricate the wire rollers occasionally. Raise the telescopic sections to access the internal wire rollers. The brake drum must not come into contact with any oil or grease!
- Lubricate the wheel bearings on the base occasionally.
- If the telescopic sections do not run smoothly, lubricate the exteriors with paraffin.
- Store the plasterboard lift in a clean, dry location.

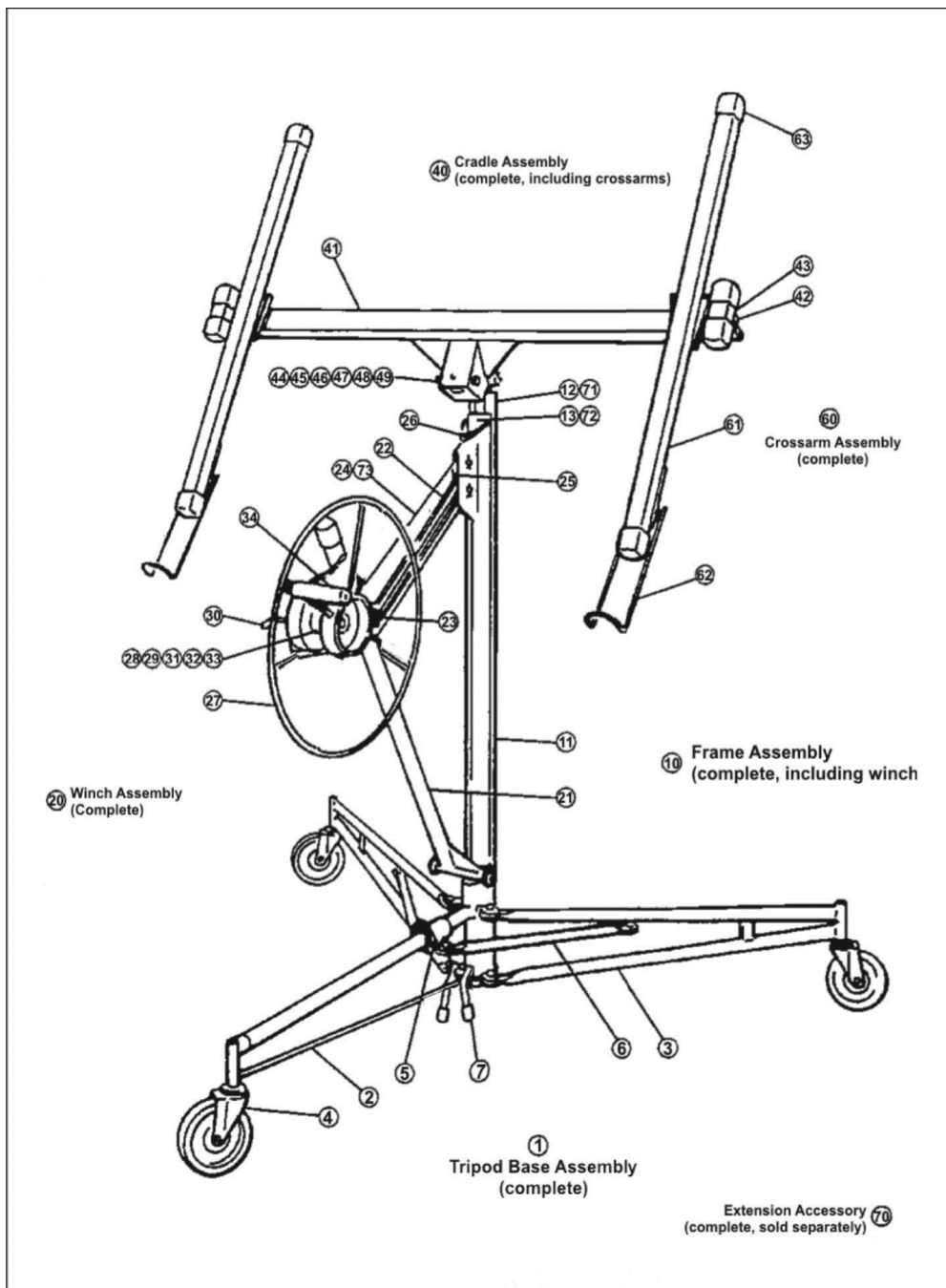

Ref. No.	Description	Qty
Tripod Base		
1	Tripod base assembly	1
2	Center Leg (with fasteners)	1
3	Outer Leg (with fasteners)	2
4	4-in Caster	3
5	Slide Yoke Ring Tension Spring	1
6	Tie Arm (with fasteners)	2
7	Rubber Backstop Tip	2

Frame Assembly		
10	Frame Assembly (Includes Winch Assembly)	1
11	Frame Housing	1
12	4-ft Inner Telescoping Section	1
13	4-ft Outer Telescoping Section (with pulley)	1

Winch Assembly		
20	Winch Assembly	1
21	Winch Host (with pin and fastener)	1
22	Slide Bar (with axle and cotter pin)	1
23	Slide Bar Lock (with fasteners)	1
24	13 ¹ / ₂ -ft Cable*	1
25	Cable Pulley (with axle and cotter pin)	3
26	Retaining Hook	1
27	Winch Wheel (with flange bearings)	1
28	7/8-in Bushing	1
29	M12x125 Bolt (with fasteners)	1
30	Brake Arm Assembly	1
31	Brake Lining (with fasteners)	1
32	Brake Arm Tension Spring	1
33	Brake Hub (with bolts)	1
34	Winch Wheel Handle	1

Ref. No.	Description	Qty
Cradle Assembly		
40	Cradle Assembl	1
41	Cradle Body	1
42	Outrigger Lock Pin (with spring & clip)	2
43	Outrigger (with end caps)	2
44	Cradle Mounting Lead Assembly	1
45	Mounting Head Body	1
46	Cradle Tilt Latch (with fasteners)	1
47	Tension Spring	1
48	Compression Spring	2
49	Hinge Pin (with bolts)	1

Cradle Crossarms		
60	Crossarm Assembly	2
61	Crossarm Body	2
62	Panel Support Lock (with fasteners)	2
63	Crossarm End Cap	2

Warranty card

Serial number	
Date of sale	
Signature and seal of the seller	

Warranty workshop marks

Date of admission	Repair completion date	Number of the defective statement	Signature

Note:

