

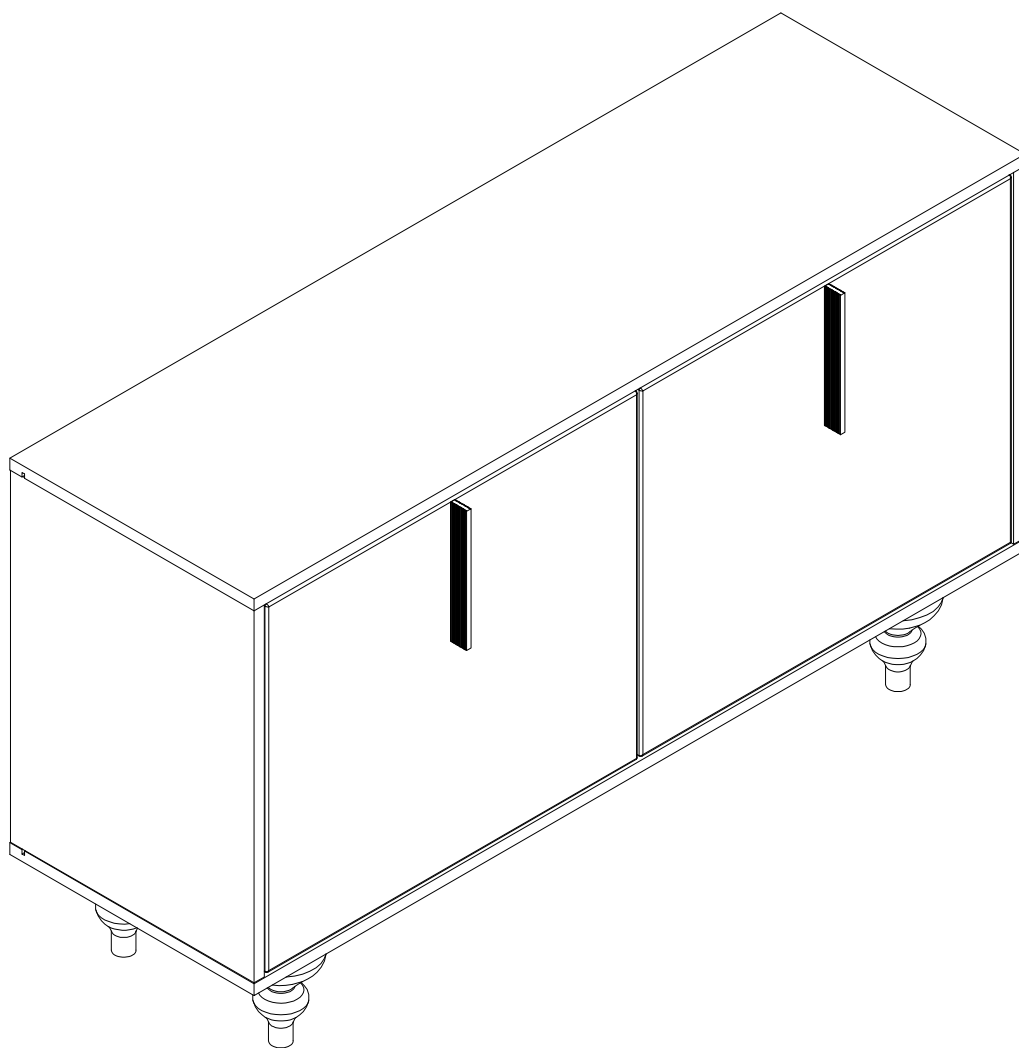

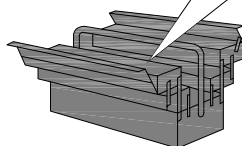

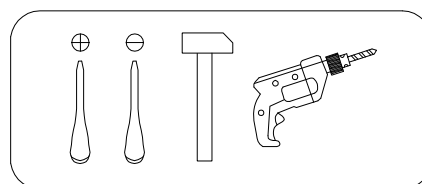

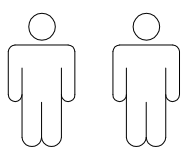



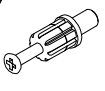

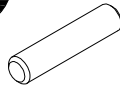

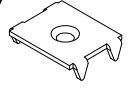
Art. Nr. 212T004 / 212T014

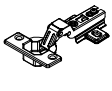

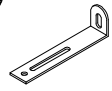
- | | |
|---|-------------------------------------|
| (D) Montageanleitung | (GB) Assembly instructions |
| (FR) Notice de montage | (IT) Istruzioni di montaggio |
| (NL) Handleiding voor de montage | (PL) Instrukcja montazu |
| (CZ) Montážní návod | (SK) Návod na montáž |
| (HU) Szerelési útmutató | (RO) Instrukțiuni de montaj |
| (TR) Montaj talimatı | (RU) Инструкция по монтажу |



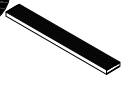
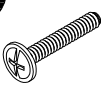

A 090913  7x32 x12	B 000146  15x12 x12	C 100640  20x0.5 x12	D 000151  8x35 x12	E 135021  x12	F 062367  x2
G 000759  3x20 x14	H 125913  x8	I 168231  x4	J 235594  6.3x16 x8	K 010942  4x16 x8	L 155999  x1
M 000754  3.5x16 x2	N 090185  4.5x45 x1	O 013859  8x40 x1	P 320188  x2	Q 005960  M4x25 x4	R 213618  11x10M8 x4

N	Size/MaB (mm)	Qty	✓	N	Size/MaB (mm)	Qty	✓
1	1202x381x16	1		6	497x579x19	1	
2	1202x381x16	1		7	497x579x19	1	
3	503x380x16	2		8	160x100x100	4	
4	503x339x16	1		9	588x513x3	1	
5	576x334x16	2		10	588x513x3	1	

Service - Dienstverlening - Serwis - Servis - Сервисная служба



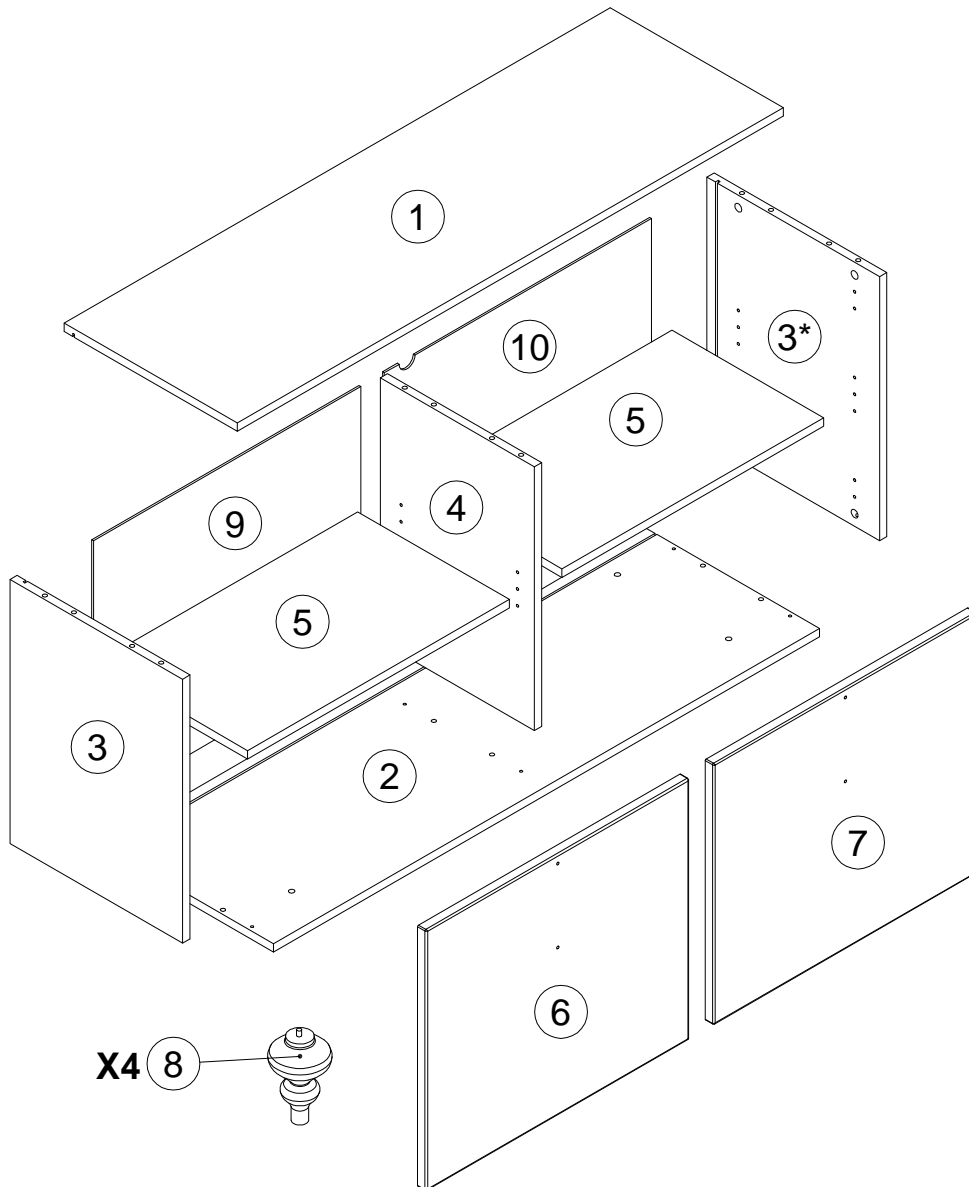
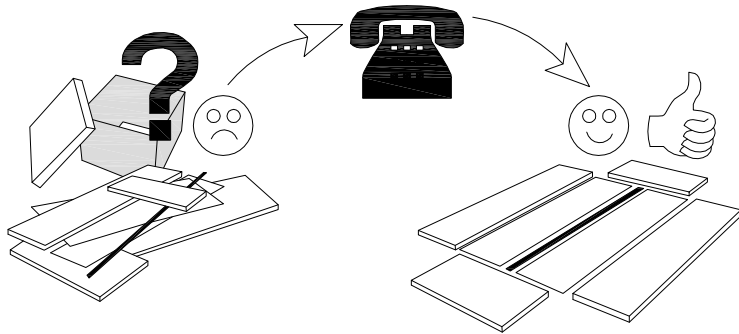
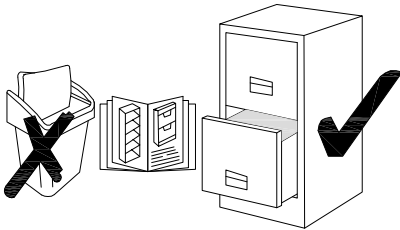

Name - Naam - Nazwa - Isim - Название

Nr. - No. - Номер

Typ - Type - Тип - Тип



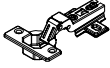

1

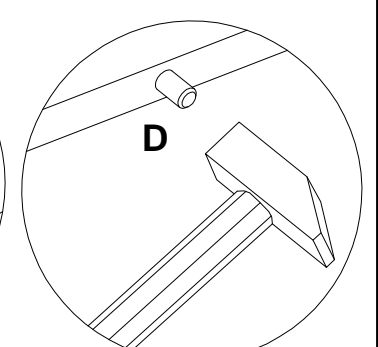
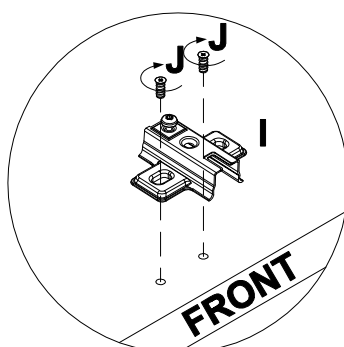
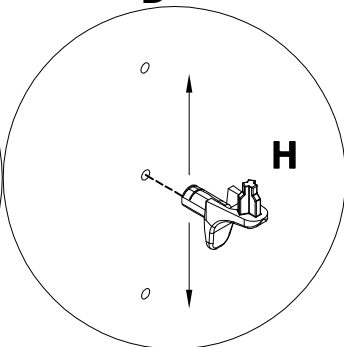
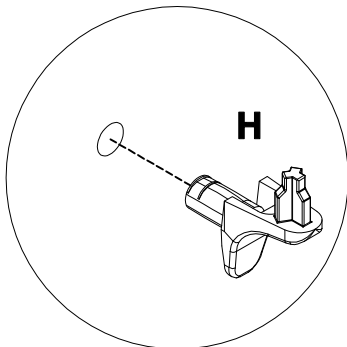
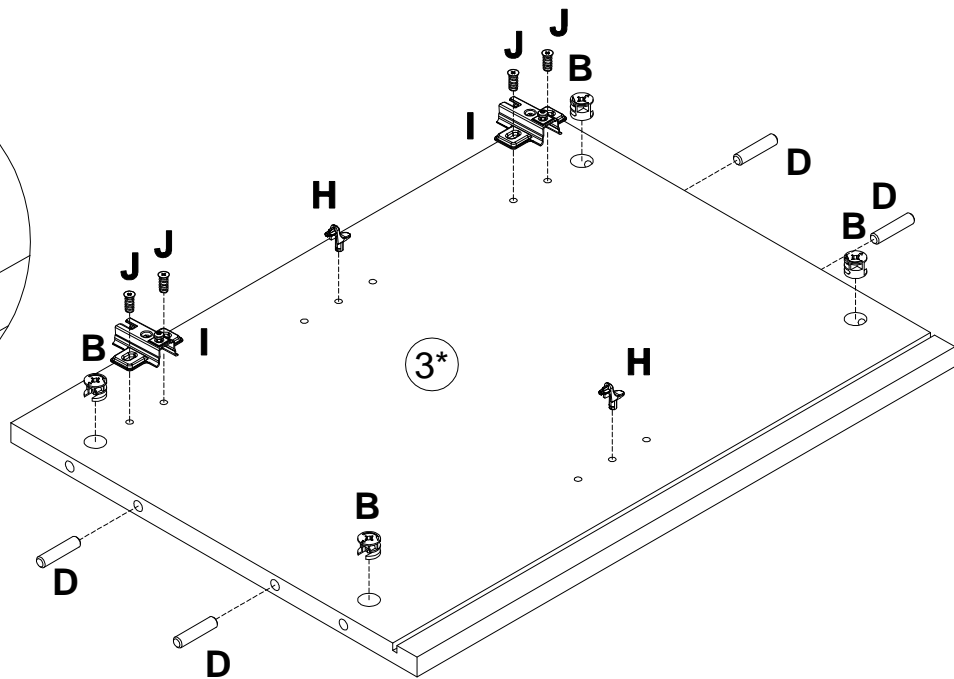
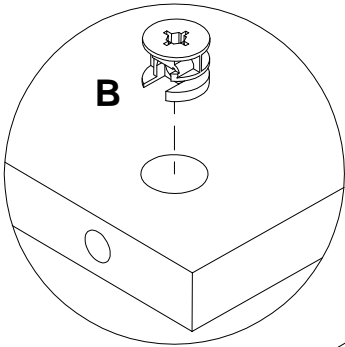
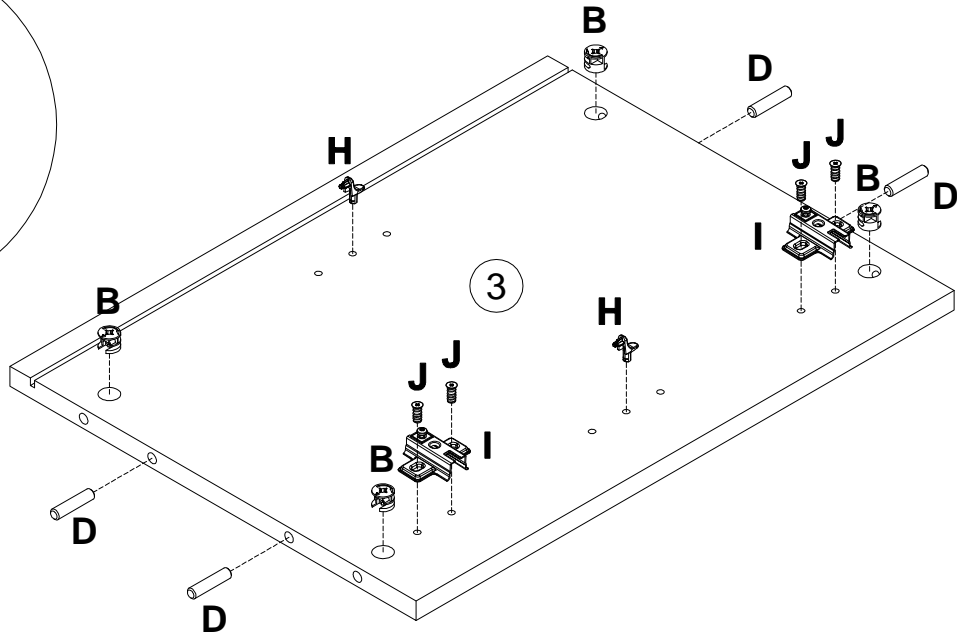
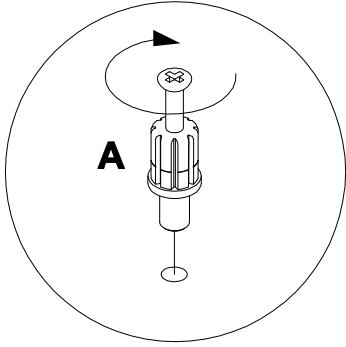
B 000146		15x12	D 000151		8x35	H 125913		x4	I 168231		x4	J 235594		6.3x16	x8
--------------------	---	-------	--------------------	---	------	--------------------	---	----	--------------------	---	----	--------------------	---	--------	----



2

B 000146  15x12 x4	D 000151  8x35 x4	H 125913  x4
---	--	--

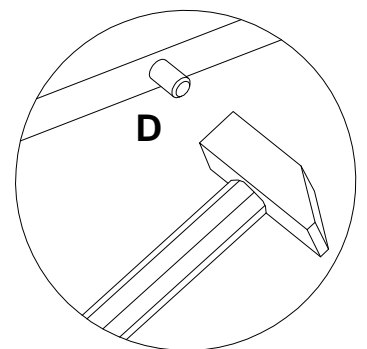
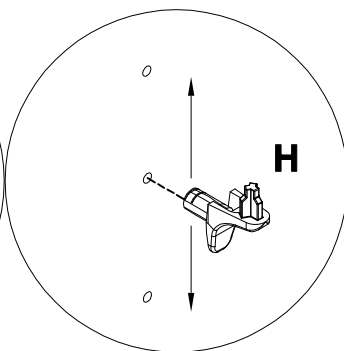
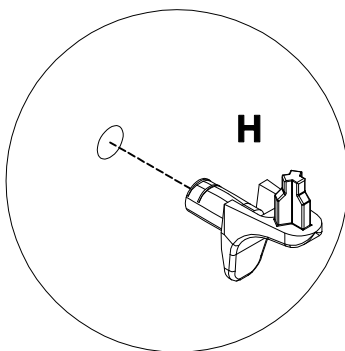
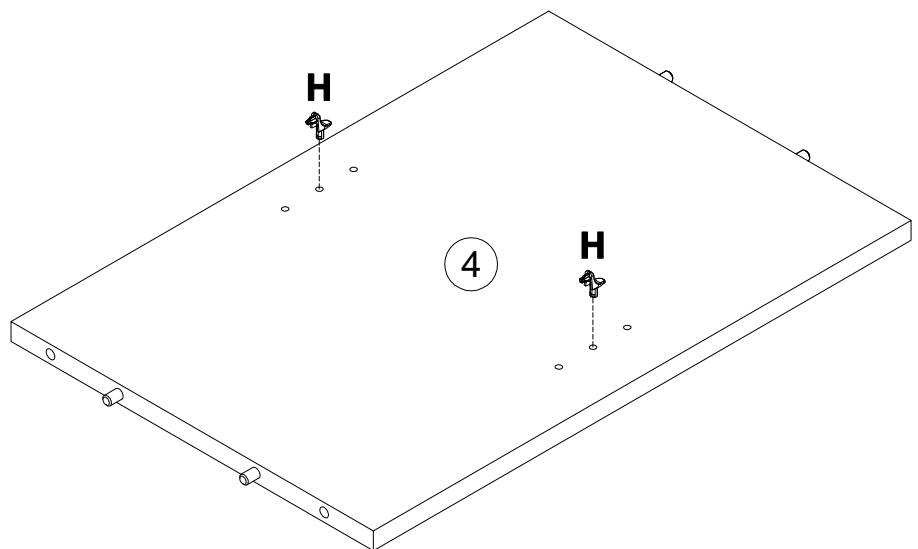
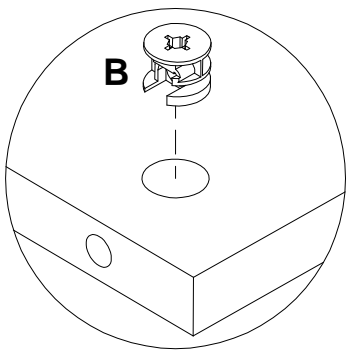
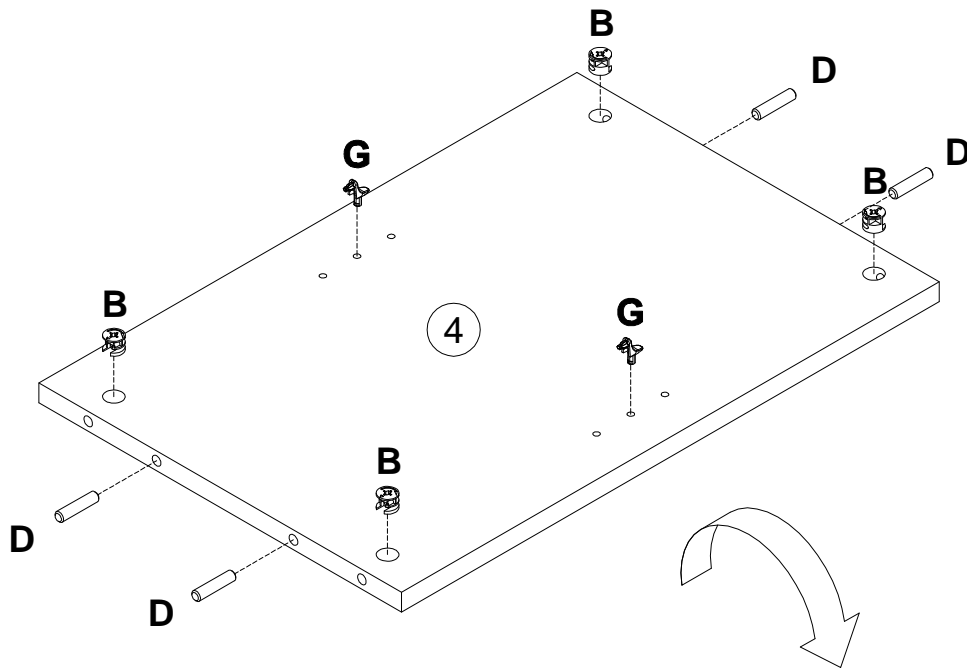

5

3

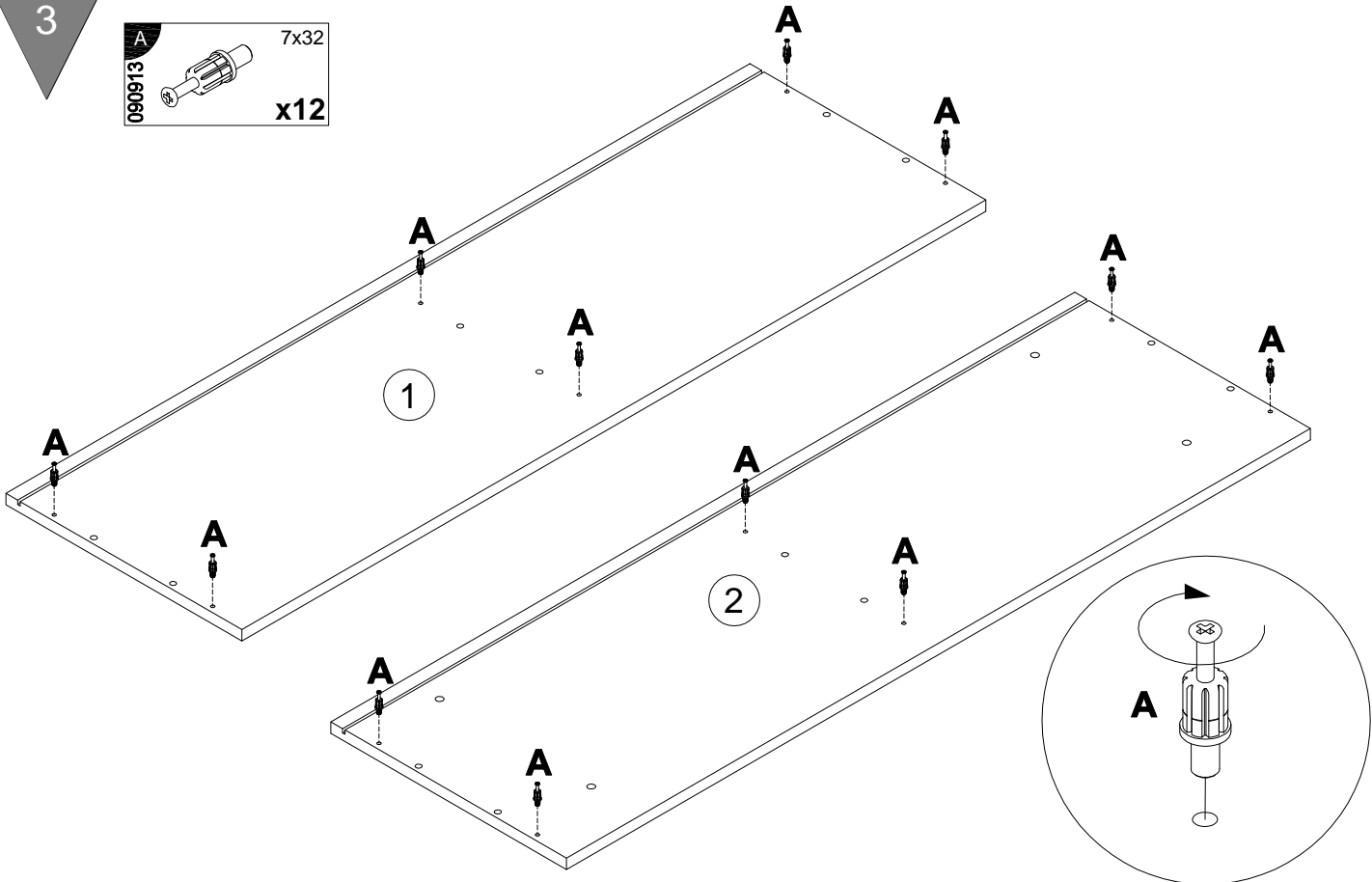
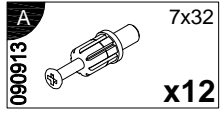

4

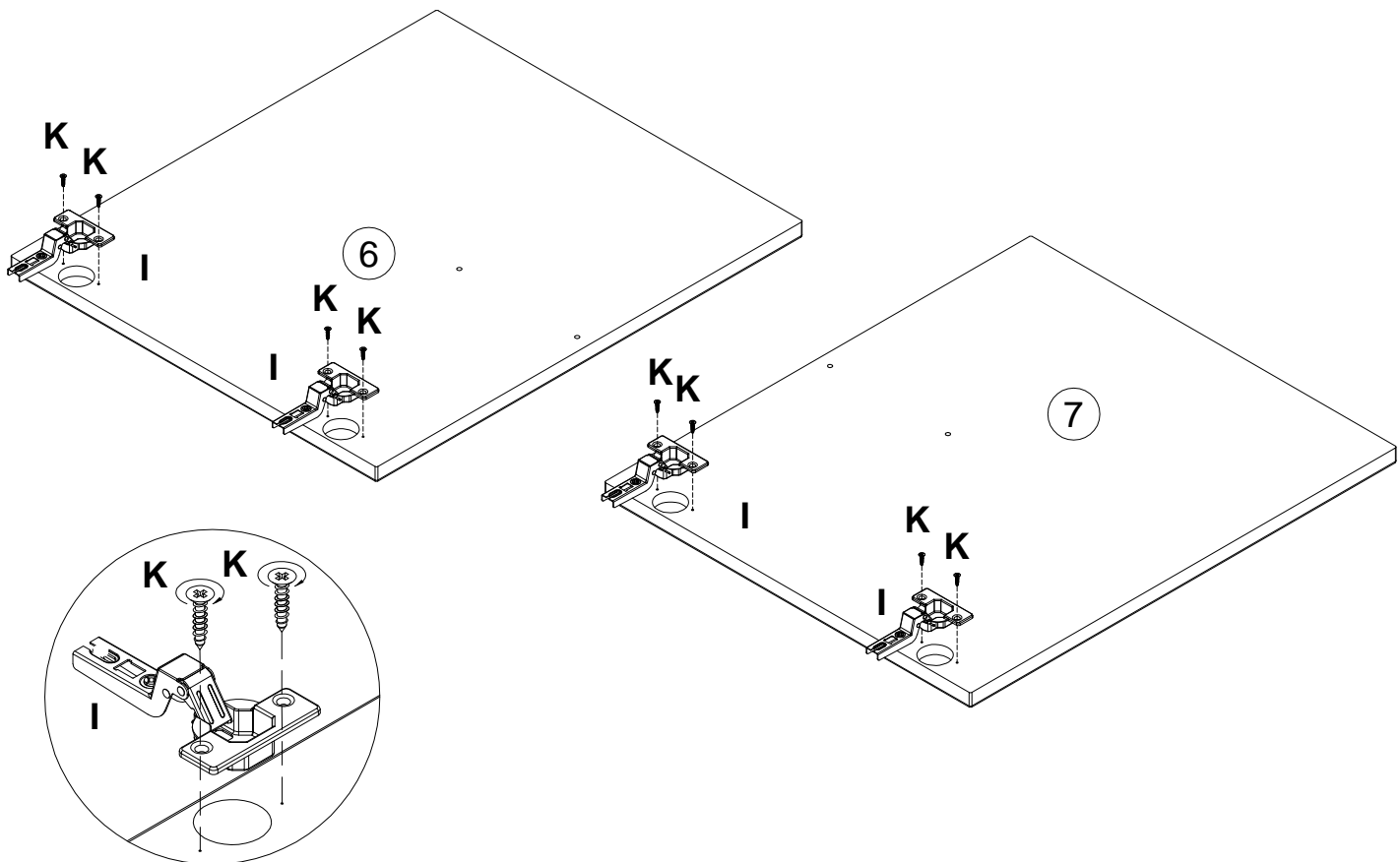
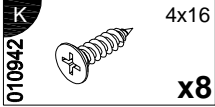
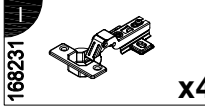

5

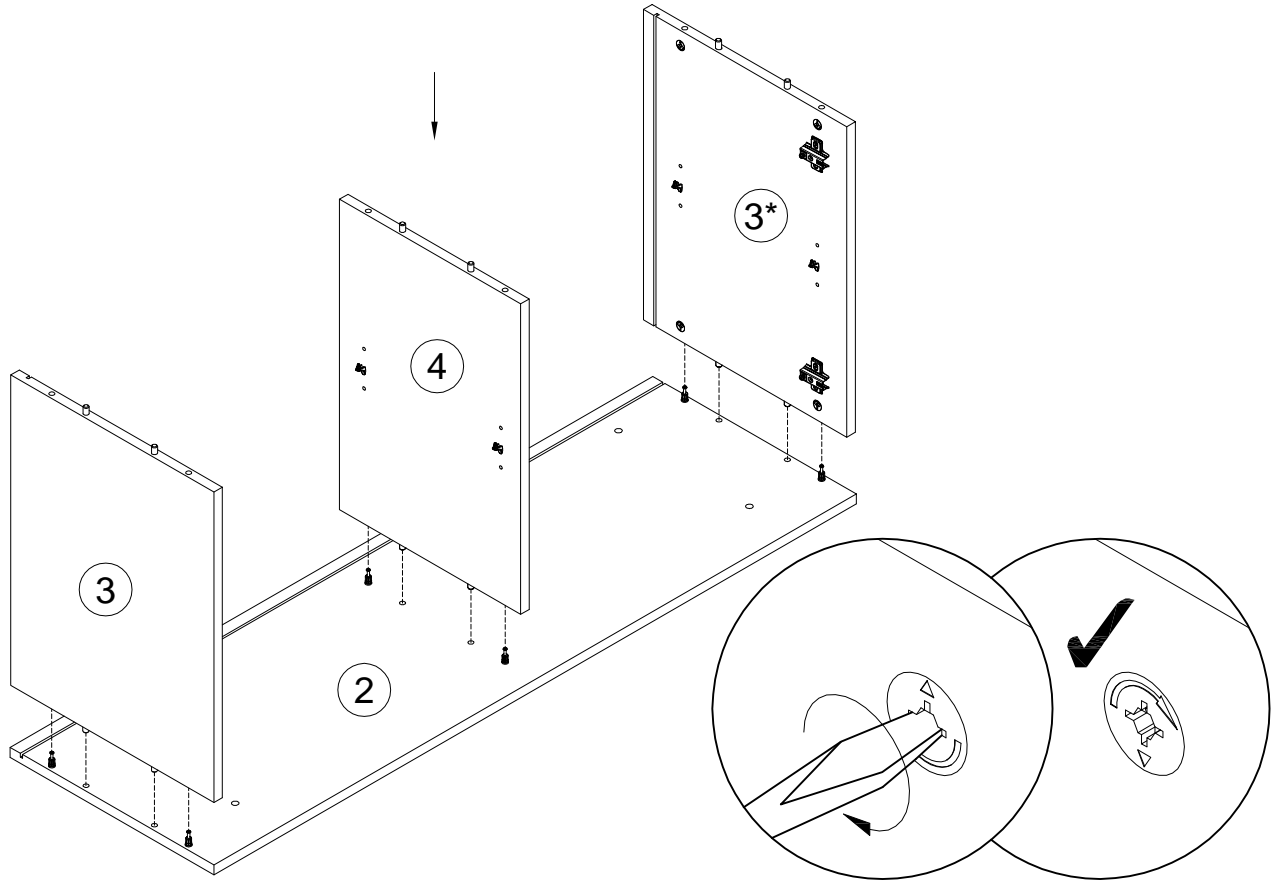

6

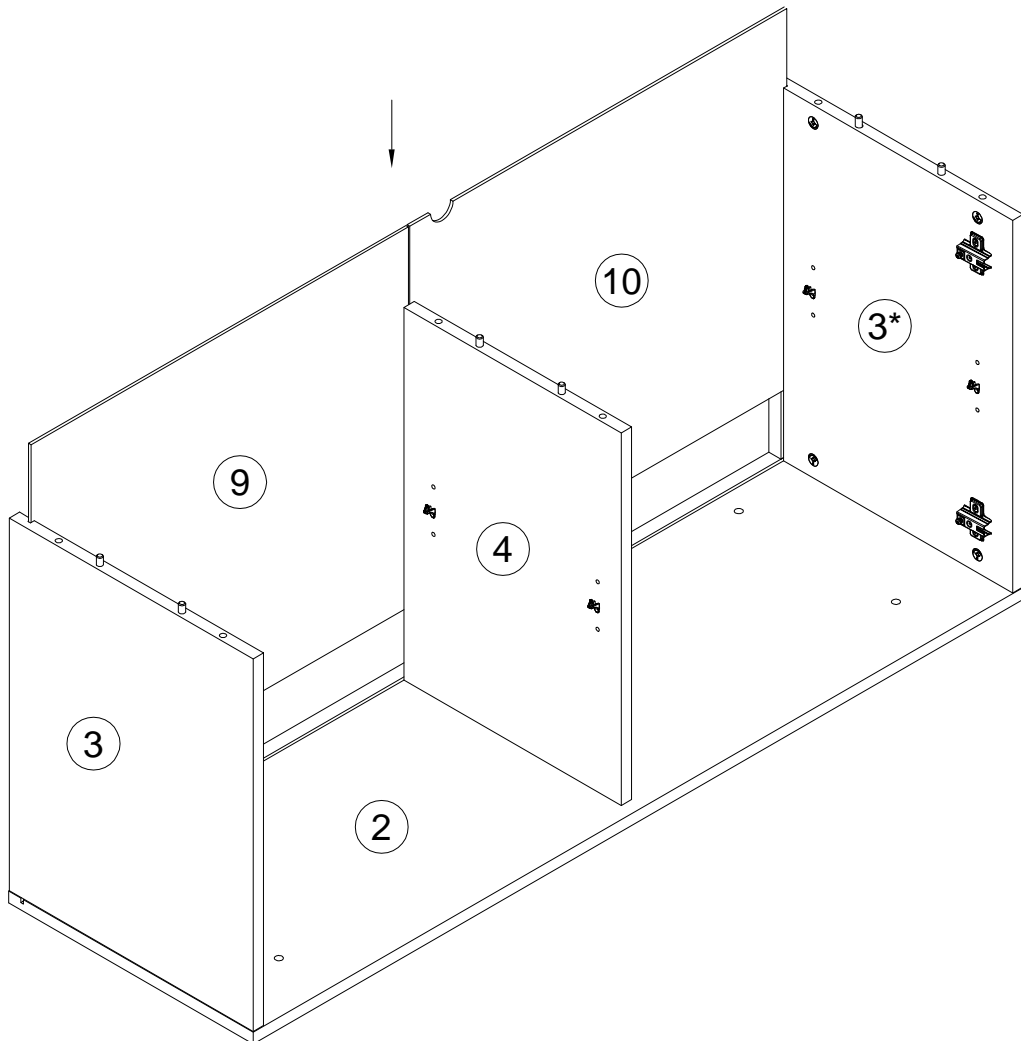

7

7

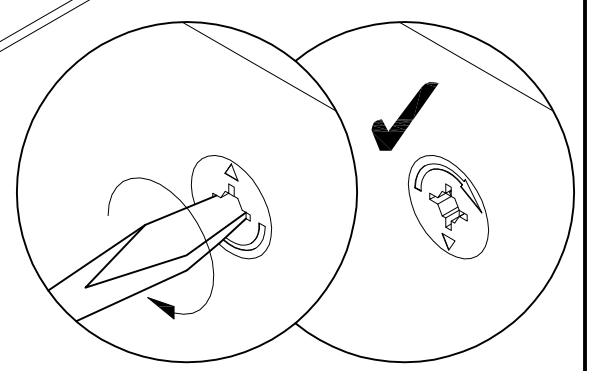
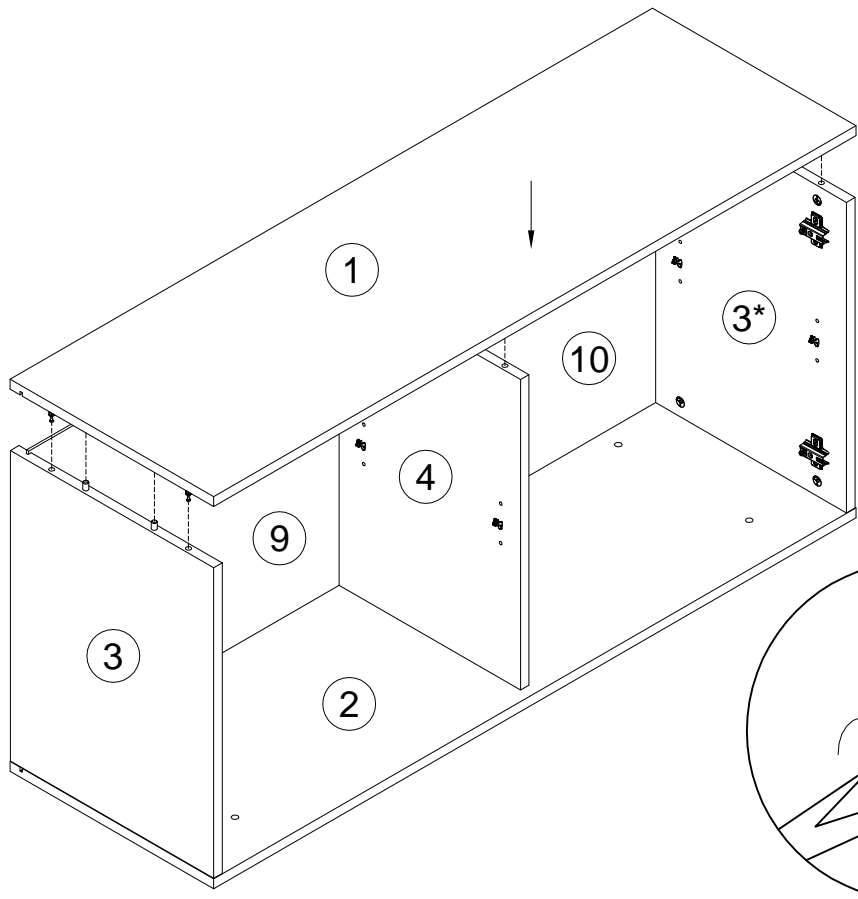

8

- | | | | | | | | | | |
|--------|--|-----|--------|--|----|--------|--|------|-----|
| 135021 | | x12 | 062367 | | x2 | 000759 | | 3x20 | x14 |
|--------|--|-----|--------|--|----|--------|--|------|-----|

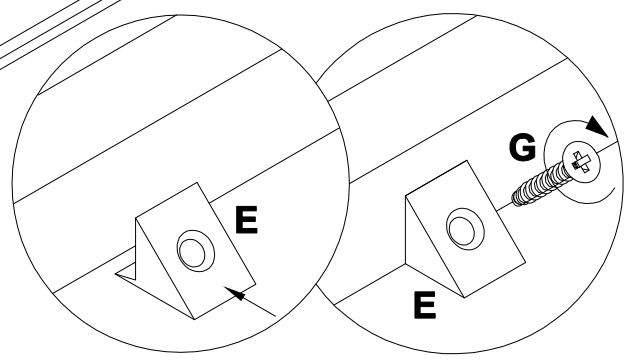
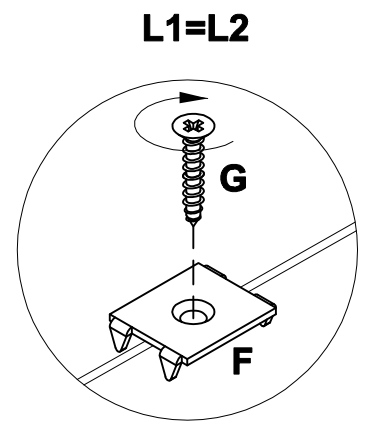
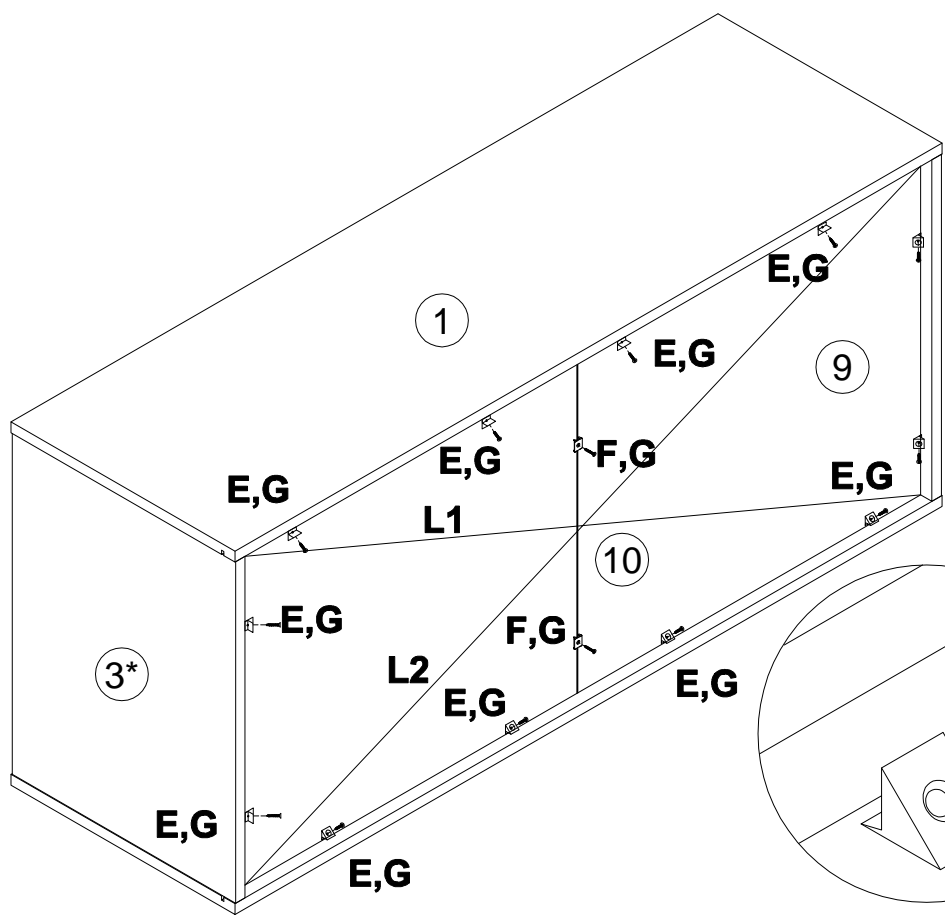

8

9

213618 **R** 11x10M8 **x4**

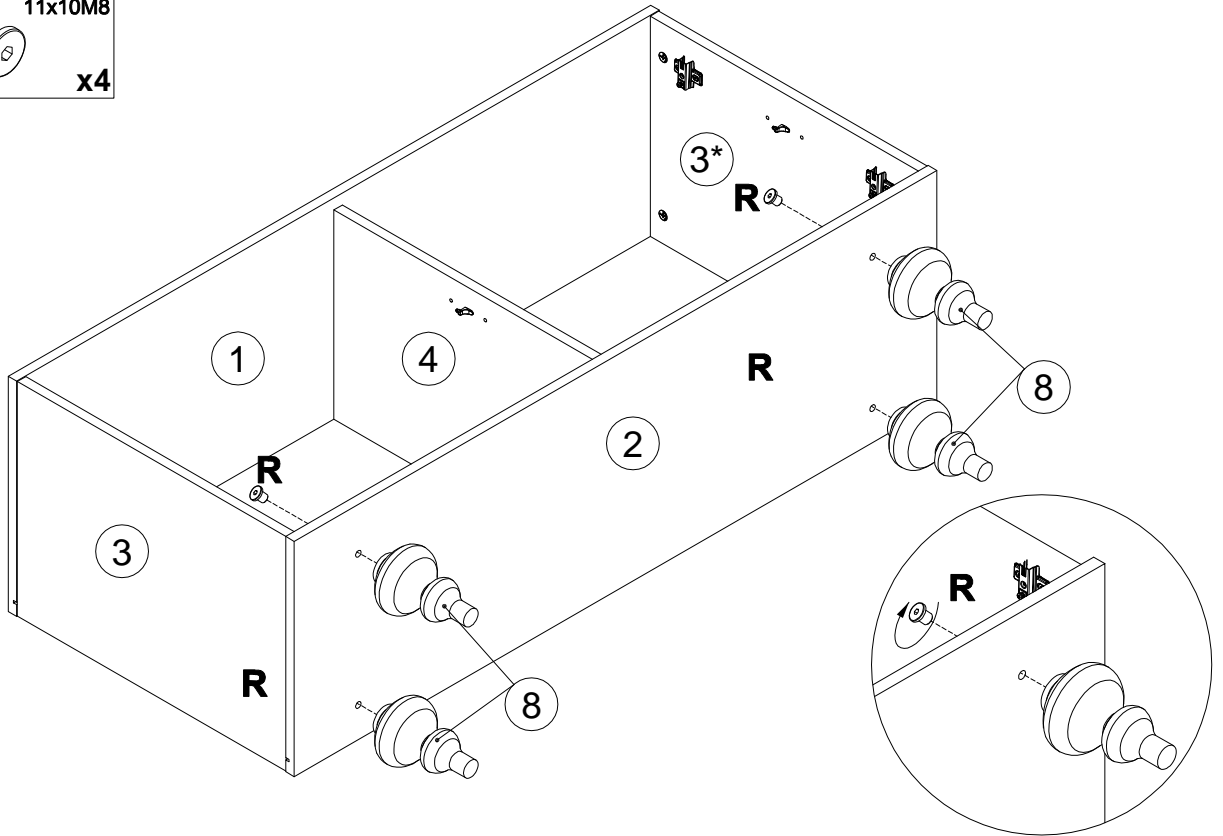

10

155999 **L** **x1**

000754 **M** 3.5x16 **x2**

090185 **N** 4.5x45 **x1**

013859 **O** 8x40 **x1**

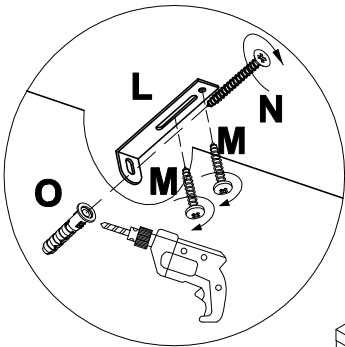

L,M,N,O

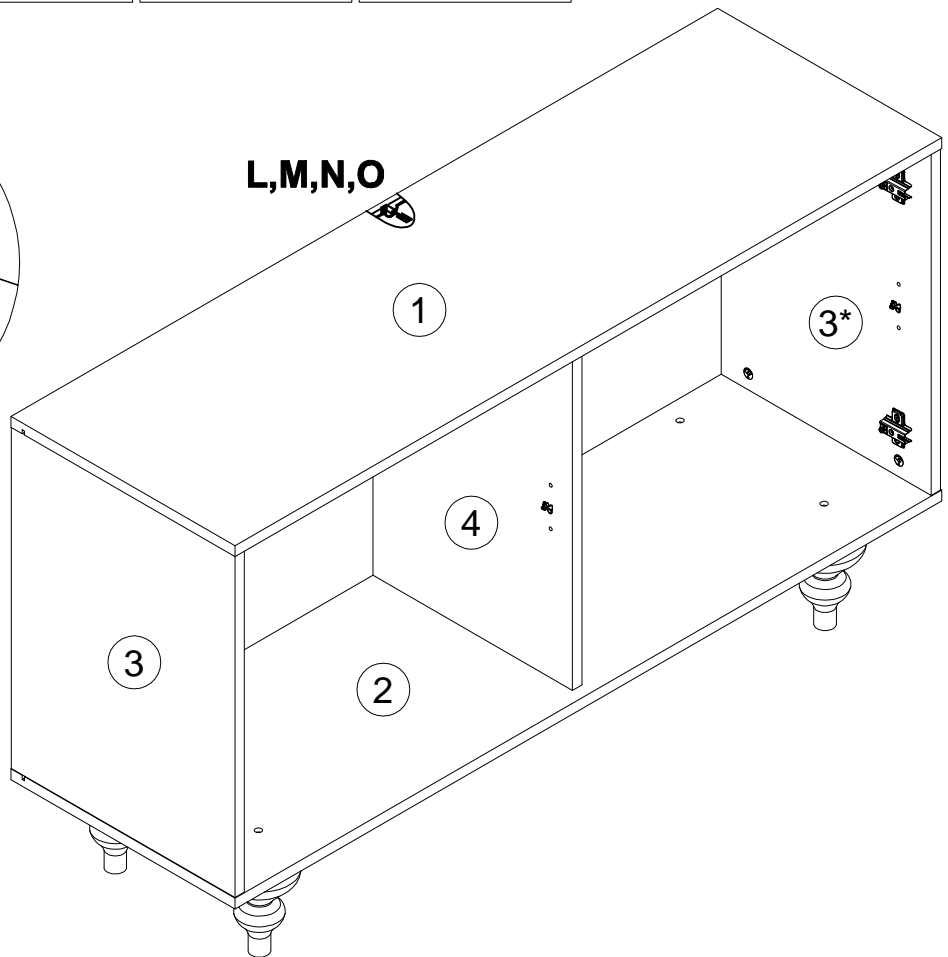

11

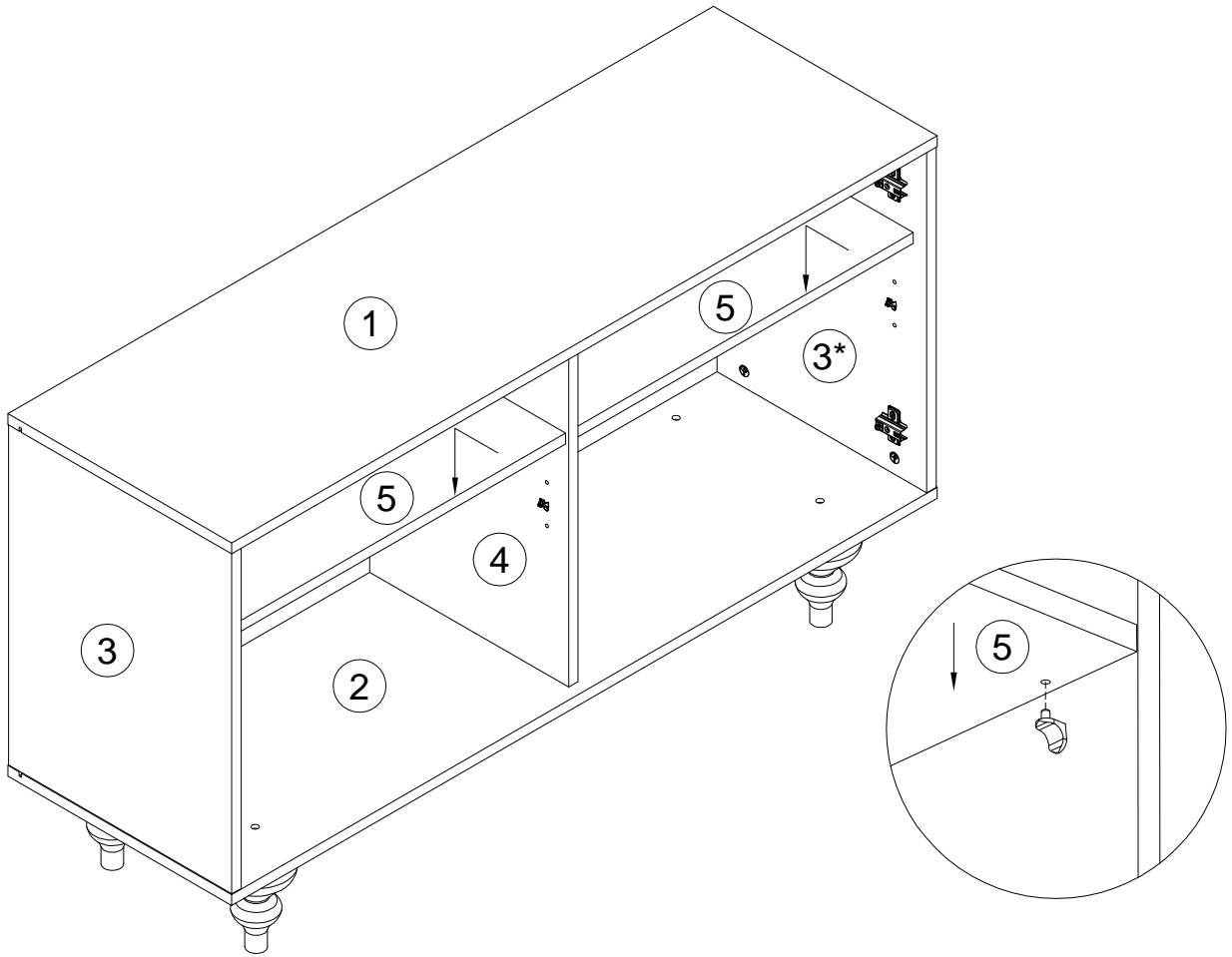

12

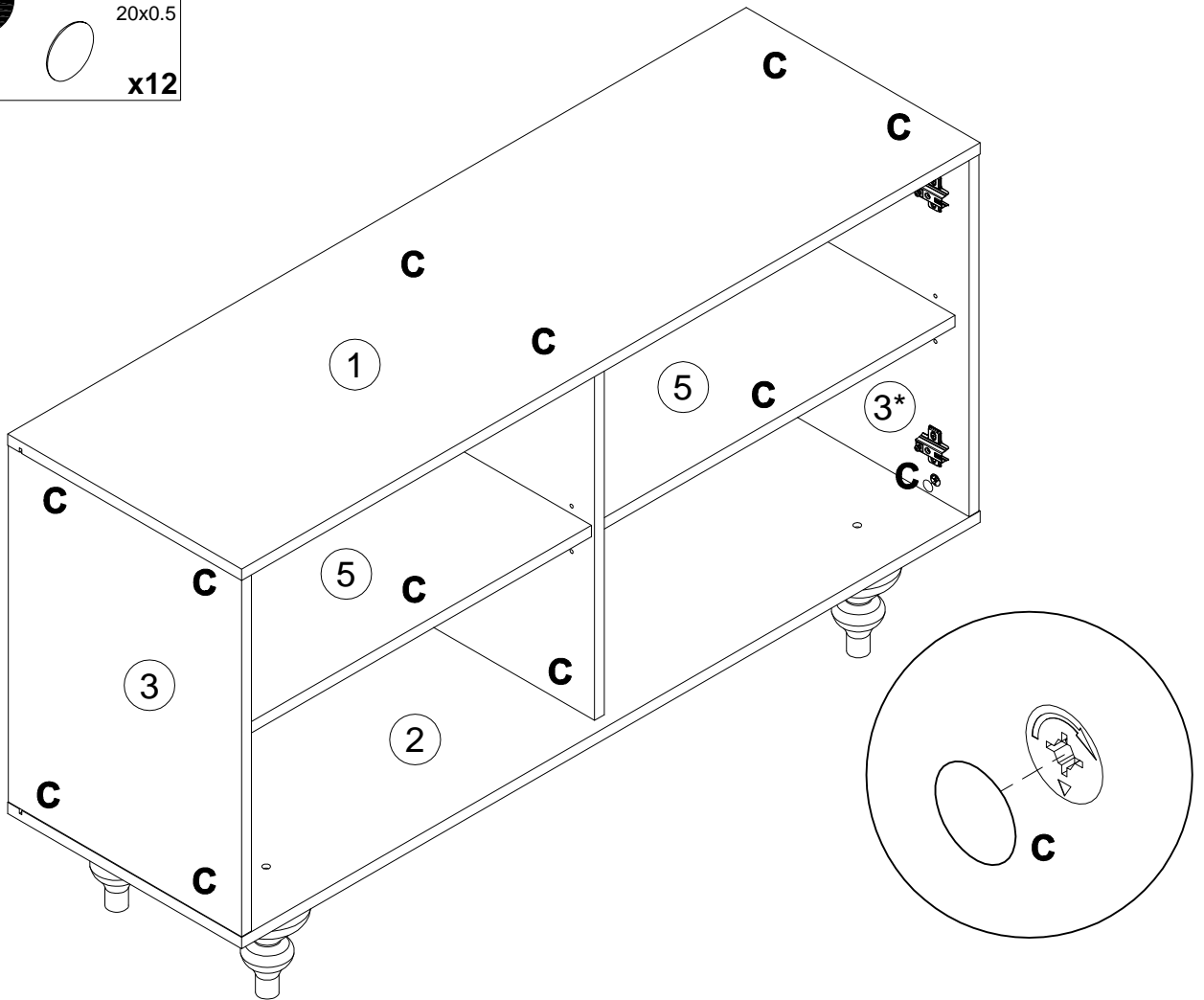
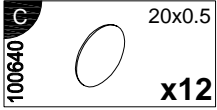

13

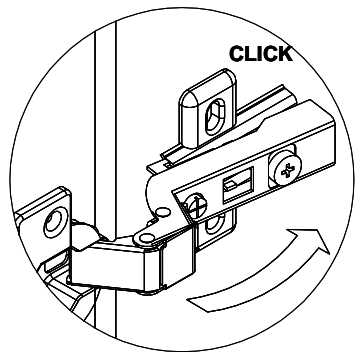
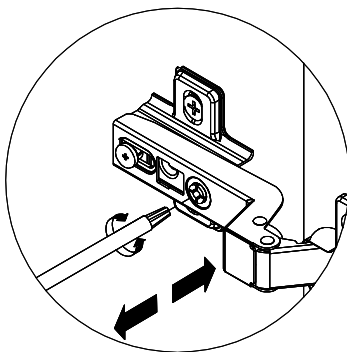
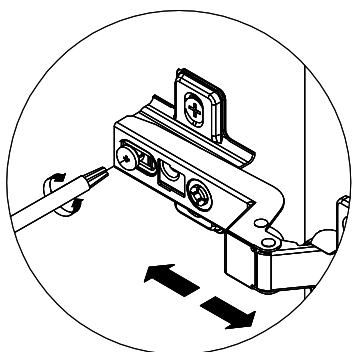
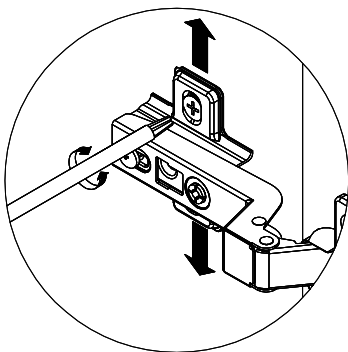
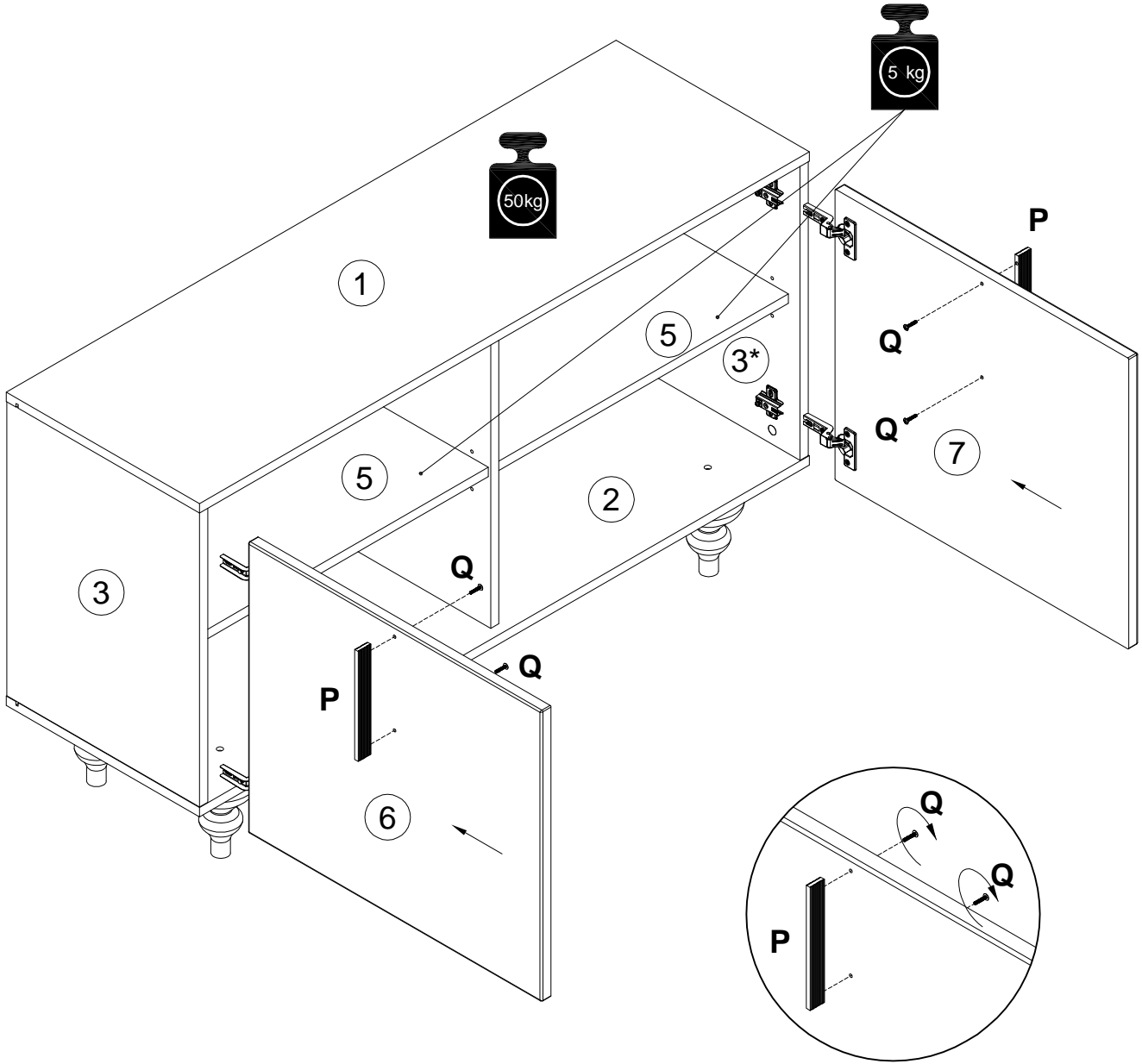
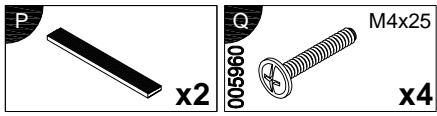

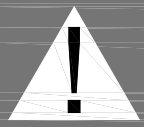

Achtung • Attention • Attenzione
Opgelet • Uwaga • Pozor • Figyelem
Atenție • Dikkat • Внимание



(D)	Wandbefestigung dient als Kippschutz – unbedingt anbringen! Bei einigen Wandtypen kann ein Spezialdübel erforderlich sein!
(GB)	The wall fastening serves to prevent tipping – be absolutely sure to mount it! For certain wall types, a special wall plug may be necessary!
(FR)	La fixation murale sert de protection contre le basculement – à installer impérativement ! Pour certains types de murs il faut des chevilles spéciales !
(IT)	Il fissaggio alla parete serve da protezione anti-ribaltamento – attaccarla assolutamente ! Per alcune strutture di parete può essere necessario un tassello speciale !
(NL)	Bevestiging aan de muur dient als kantelbescherming – zeker en vast bevestigen ! Bij enkele muurtypes is een speciale plug misschien vereist !
(PL)	Mocowanie do ściany jest jednocześnie zabezpieczeniem przed przewróceniem – koniecznie zamontować! Do niektórych rodzajów ścian koniecznie zastosować specjalne kołki mocujące.
(CZ)	Montáž na stěnu slouží jako ochrana proti převrhnuti – bezpodmienečně umístěte! Uněkterých typů stěn může být zapotřebí speciální hmoždinka !
(SK)	Upevnenie na stenu slúži ako ochrana proti prevráteniu – bezpodmienečne použite! Pre niektoré druhy stien môže byť potrebná špeciálna hmoždenka !
(HU)	A terméket a falhoz kel rögzíteni, különben az felborulhat! Egyes faltípusoknál speciális tiplit kell használni !
(RO)	Sistemul de fixare la perete servește ca protecție la răsturnare – de montat obligatoriu! Pentru unele tipuri de pereți este posibil să fie necesar un diblu special !
(TR)	Duvardaki sabitleme, devrilmeye karşı bir emniyet tedbiridir ve mutlaka monte edilmelidir! Bazı duvar tiplerinde bunun için özel bir düble gerekli olabilir !
(RU)	Обязательно установите крепление на стене во избежание опрокидывания ! Для некоторых типов стен может потребоваться специальный дюбель !