

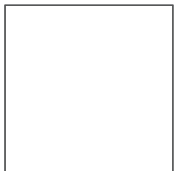

Disney



Booklet available in English on  
Livret disponible en français sur  
Folleto disponible en español en





## WE'RE MAKING OUR PACKAGING MORE SUSTAINABLE

We're transitioning from single-use plastic to paper-based packaging. As we progress, you may find a mix of paper and plastic in our boxes.

## NOUS RENDONS NOS EMBALLAGES PLUS DURABLES

Nous passons des emballages en plastique à usage unique aux emballages à base de papier. Durant la transition, vous pourriez trouver un mélange de papier et de plastique dans nos boîtes.

## QUEREMOS HACER MÁS SUSTENTABLES NUESTROS MATERIALES DE EMBALAJE

Estamos cambiando las bolsas de plástico desechables por bolsas con base de papel. Conforme avanzamos en este propósito, puedes encontrar una mezcla de papel y de plástico en nuestras cajas.

[LEGO.com/sustainable-packaging](https://www.lego.com/sustainable-packaging)

# LEGO® VIP

- 1.** SIGN UP  
INSCRIVEZ-VOUS  
REGÍSTRATE



- 2.** EARN POINTS FOR PURCHASES  
GAGNEZ DES POINTS POUR  
VOS ACHATS  
GANA PUNTOS POR TUS  
COMPRAS

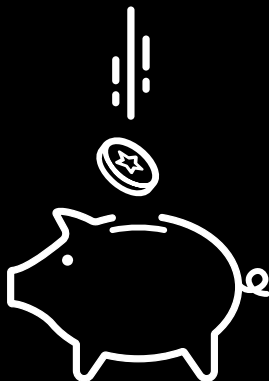

- 3.** REDEEM POINTS FOR  
REWARDS, EXPERIENCES,  
DISCOUNTS & MORE  
ÉCHANGEZ DES POINTS  
CONTRE DES RÉCOMPENSES,  
DES EXPÉRIENCES, DES  
RÉDUCTIONS ET PLUS ENCORE  
CANJEA PUNTOS POR  
RECOMPENSAS, EXPERIENCIAS,  
DESCUENTOS Y MUCHO MÁS

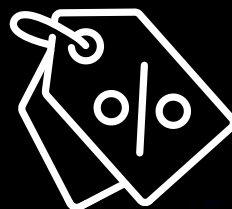
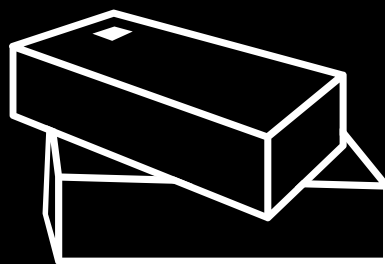



## Lights, camera, imagination

Since the Walt Disney Studios were founded in 1923, the name has been synonymous with spellbinding stories and groundbreaking animated movies. From *Steamboat Willie* to *Encanto* and beyond, Disney's characters and technological inventions continue to spark joy, awe and imagination in fans of all ages. Enjoy building, as we pay tribute to Walt Disney, his legacy in movie history and the innovations that made his dreams come true.

## Lumières, caméra, imagination

Depuis sa création en 1923, la société Walt Disney Studios est reconnue pour ses histoires envoûtantes et ses films d'animation révolutionnaires. De *Steamboat Willie* à *Encanto* et plus loin encore, les personnages et les inventions technologiques de Disney continuent à inspirer joie, admiration et imagination aux amateurs de tous âges. Amusez-vous à construire cet hommage à Walt Disney, à l'empreinte qu'il a laissée sur l'histoire du cinéma et aux innovations qui ont permis de concrétiser ses rêves.

## Luces, cámara, ¡imaginación!

Desde la fundación de Walt Disney Studios en 1923, su nombre se ha convertido en sinónimo de fascinantes historias y revolucionarias películas animadas. Desde *El barco de vapor Willie* hasta *Encanto* y todo lo que está por venir, los personajes e inventos tecnológicos de Disney continúan despertando alegría, admiración e imaginación en fans de todas las edades. Disfruta de la construcción mientras honras a Walt Disney, su legado para la historia del cine y las innovaciones que hicieron realidad sus sueños.



## Recreating the magic

Inspired by 1920s-style movie cameras, we incorporated distinct details that help bring the Disney movie magic to life.

## Recréer la magie

Inspirés par les caméras de cinéma des années 1920, nous avons incorporé des détails distincts qui contribuent à donner vie à la magie des films Disney.

## Cómo recrear la magia

Tomando como inspiración las cámaras de cine de la década de 1920, agregamos algunos de los detalles distintivos que hacen realidad la magia de las películas Disney.



See how Disney's cutting-edge multiplane camera worked /  
Découvrez comment fonctionnait la caméra multiplan de pointe de Disney /  
Descubre cómo operaba la innovadora cámara multiplano de Disney



Turn the crank to hear the sound of film recording /  
Tournez la manivelle pour entendre le son de l'enregistrement d'un film /  
Gira la palanca para escuchar cómo sonaba la grabación de la película

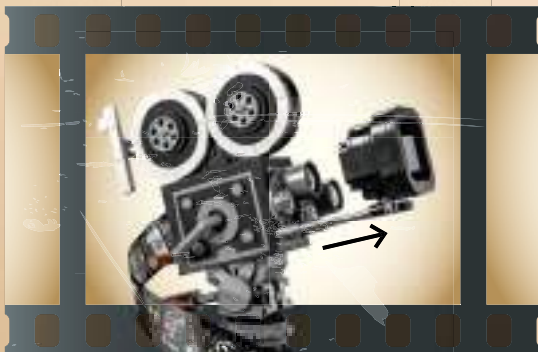

Slide the matte box back and forth /  
Faites glisser le parasoleil d'avant en arrière /  
Mueve la matte box hacia atrás y hacia adelante



Rotate the disc to switch between the three lenses /  
Tournez le disque pour passer d'un objectif à l'autre /  
Gira el disco para cambiar entre los tres lentes

# Movies that move us

# Des films qui nous touchent

# El cine que nos inspira

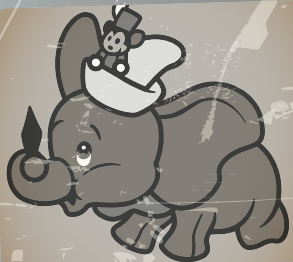

1941  
*Dumbo*



1942  
*Bambi*

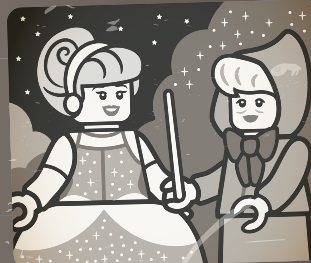

1950  
*Cinderella /  
Cendrillon /  
Cenicienta*



1951  
*Alice in Wonderland /  
Alice au pays des  
merveilles / Alicia en el  
país de las maravillas*



1977  
*The Rescuers / Les Aventures  
de Bernard et Bianca /  
Bernardo y Bianca*

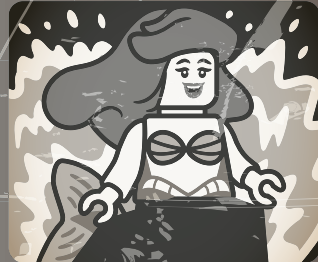

1989  
*The Little Mermaid /  
La Petite Sirène /  
La sirenita*



1990  
*Beauty and the Beast /  
La Belle et la Bête /  
La bella y la bestia*



1994  
*The Lion King /  
Le Roi Lion /  
El rey león*

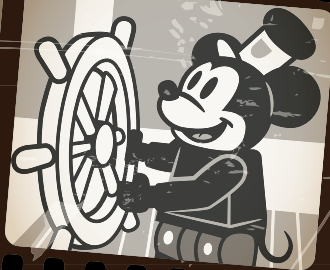

**1928**  
*Steamboat Willie /  
El barco de vapor Willie*



**1937**  
*Snow White /  
Blanche-Neige /  
Blancanieves*



**1940**  
*Pinocchio /  
Pinocho*

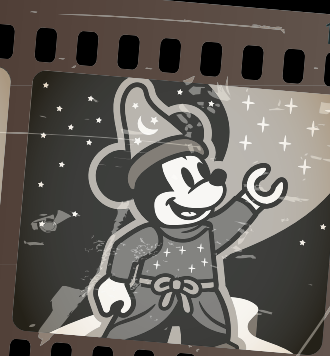

**1940**  
*Fantasia /  
Fantasia*



**1959**  
*Sleeping Beauty /  
La Belle au bois dormant /  
La bella durmiente*



**1963**  
*The Sword in the Stone /  
Merlin l'Enchanteur /  
La espada en la piedra*



**1967**  
*The Jungle Book /  
Le Livre de la jungle /  
El libro de la selva*



**1973**  
*Robin Hood /  
Robin des Bois*



**1998**  
*Mulan /  
Mulán*



**2009**  
*The Princess and the Frog /  
La Princesse et la Grenouille /  
La princesa y el sapo*

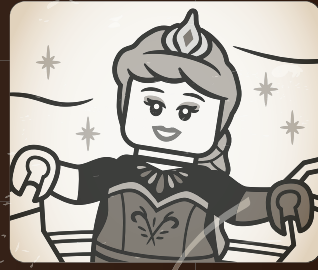

**2013**  
*Frozen /  
La Reine des neiges*

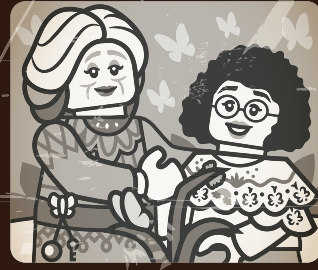

**2021**  
*Encanto*

# A note from the LEGO® designers

## Un mot des concepteurs LEGO®

## Una nota de los diseñadores de LEGO®

"The model is designed as a tribute to Walt Disney himself, so adding LEGO® brick versions of the tools and inventions he used for his animated movies seemed like a good place to start. With the classic vintage movie camera as the central display piece, we included a clapperboard, a small, hidden office and a minifigure-scale multiplane camera that was used for the early 2D animated movies. The three-layered scene from Walt Disney's short, *The Old Mill* (1937), is depicted just as it was in the real thing!"

- Wes Talbott,  
LEGO® Design Master

« Le modèle a été conçu comme un hommage à Walt Disney lui-même. Ajouter des versions en briques LEGO® des outils et inventions qu'il utilisait donc être un bon point de départ. Avec la caméra de cinéma classique d'époque comme pièce centrale, nous avons inclus une claquette, un petit bureau caché et une version à l'échelle de figurine de la caméra multiplane qui était utilisée pour les premiers films d'animation en 2D. La scène à trois niveaux du court métrage *Le Vieux Moulin* (1937) de Walt Disney est représentée telle qu'elle était dans la vraie vie ! »

- Wes Talbot,  
maître de la conception LEGO®

"El modelo está diseñado como un homenaje al mismo Walt Disney, por lo que agregar versiones de bricks LEGO® de las herramientas e inventos que utilizó en sus películas animadas parecía un buen punto de partida. Con la clásica cámara de cine retro como elemento central, incluimos una claqueta, una pequeña oficina oculta y una cámara multiplano a escala de minifigura como las que se utilizaron en las primeras películas animadas en 2D. ¡La escena de tres capas del cortometraje de Walt Disney *El viejo molino* (1937) está reproducida tal y como realmente se filmó!"

- Wes Talbot,  
maestro de diseño de LEGO®

**Camilla Thorsted Cording**  
LEGO Graphic Designer /  
graphiste LEGO /  
diseñadora gráfica de LEGO





**Wes Talbott**

LEGO Design Master /  
maître de la conception LEGO /  
maestro de diseño de LEGO



"In our graphic design team, we worked with hundreds of assets to narrow down every detail you see in the set. For the multiplane camera, each layer is a detailed graphic on its own. From dozens of Disney classics, we selected some of the milestone movies from the past 100 years that we know fans love. And for the first time, we are excited to present Dumbo and Bambi as LEGO® figures!"

- Camilla Thorsted Cording,  
LEGO® Graphic Designer

« Notre équipe de conception graphique a utilisé des centaines de ressources pour affiner chaque détail présent dans l'ensemble. Pour la caméra multiplane, chaque couche est une image détaillée à part entière. Parmi des dizaines de classiques de Disney, nous avons sélectionné certains des films les plus marquants et appréciés des amateurs au cours des 100 dernières années. Et nous sommes ravis de présenter Dumbo et Bambi sous forme de figurines LEGO® pour la première fois !

- Camilla Thorsted Cording,  
graphiste LEGO®

"En el equipo de diseño gráfico, trabajamos con cientos de materiales para elegir cuidadosamente todos los detalles que se pueden ver en el set. En la cámara multiplano, cada capa tiene un gráfico detallado diferente. De las docenas de clásicos de Disney, elegimos los hitos cinematográficos de los últimos 100 años que sabíamos que más apreciarían los fans. ¡También nos emociona haber presentado por primera vez a Dumbo y Bambi como figuras LEGO®!"

- Camilla Thorsted Cording,  
diseñadora gráfica de LEGO®

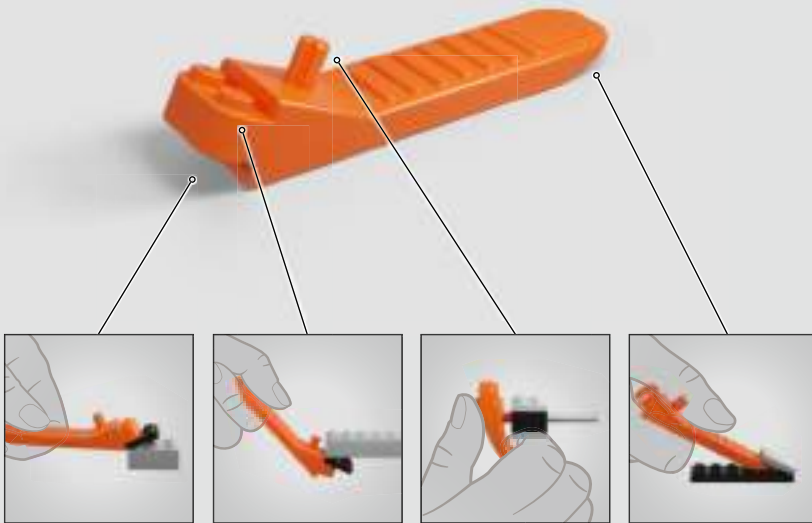

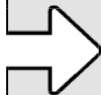
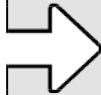
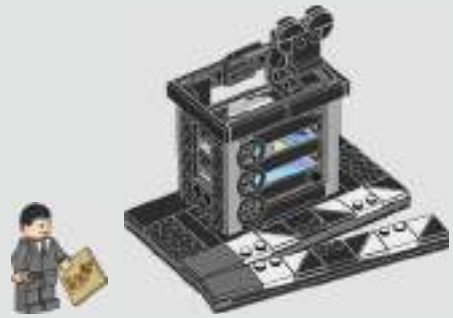
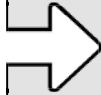

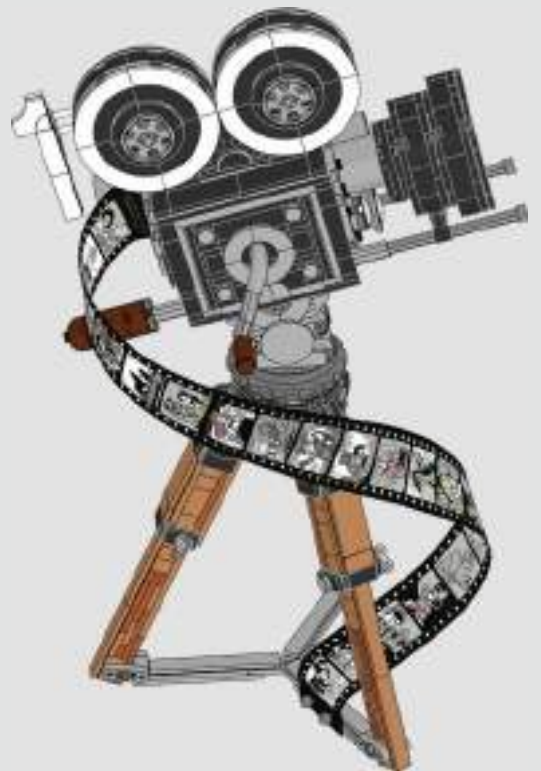
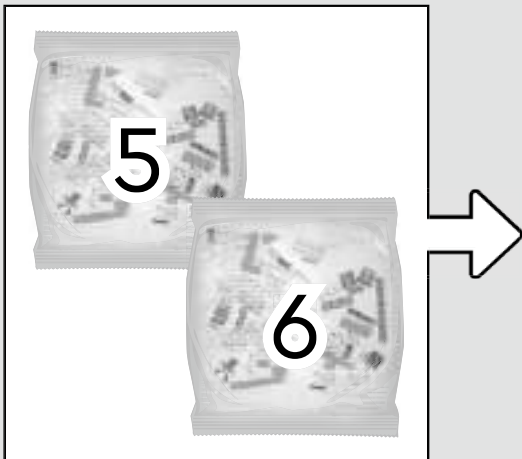
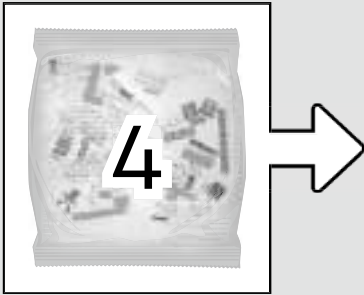

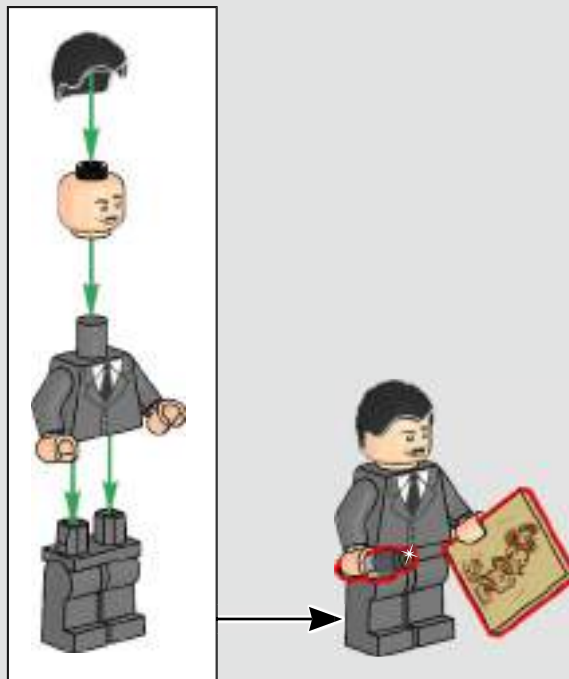

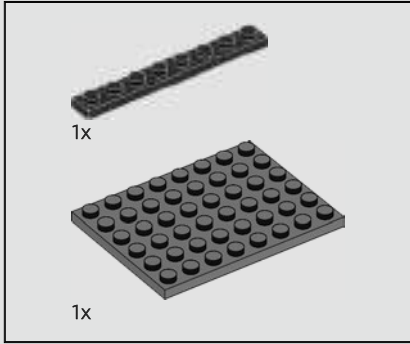
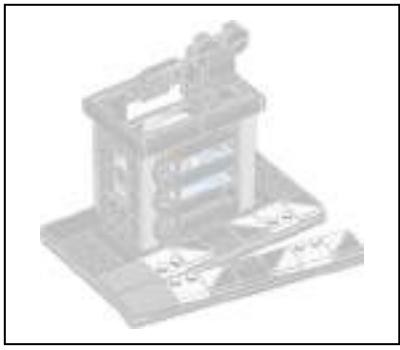

1

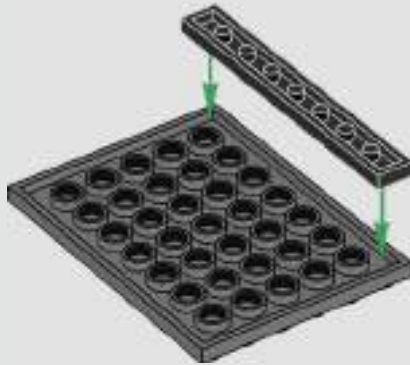



2

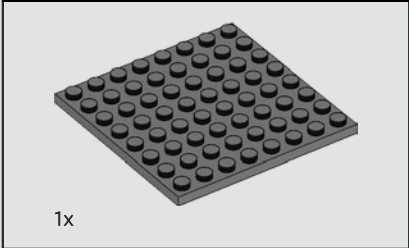
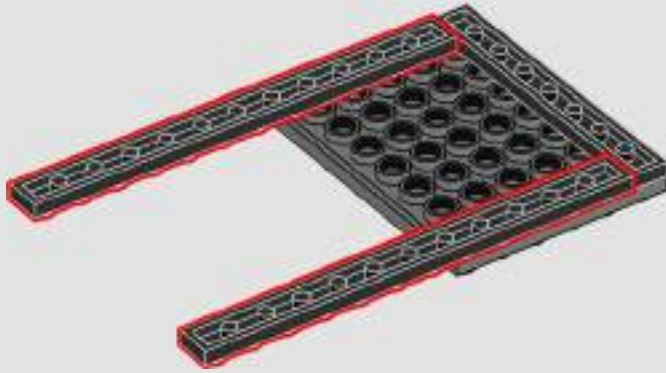

3



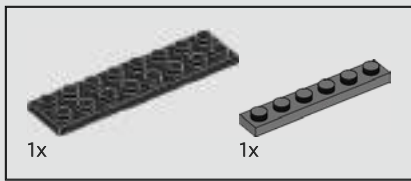

4

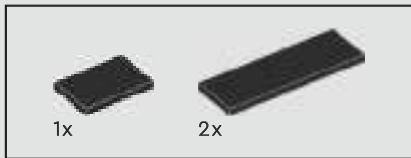
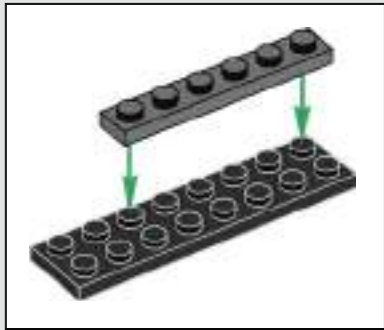

5

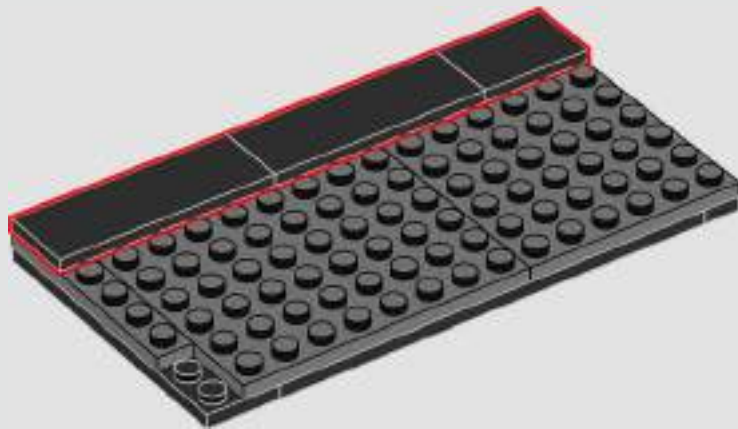



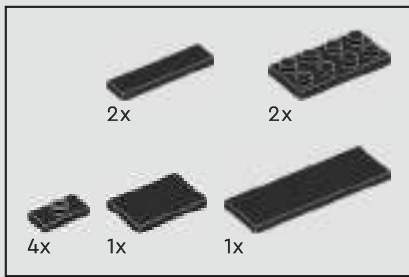

6

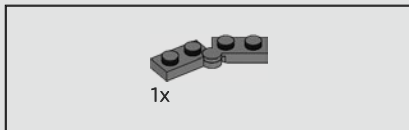
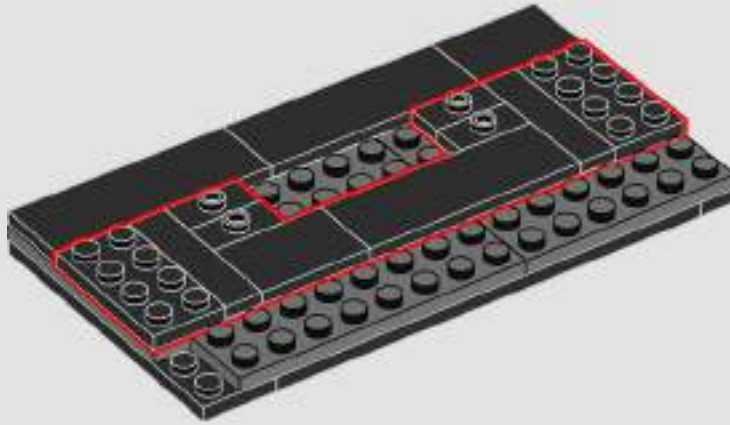

7

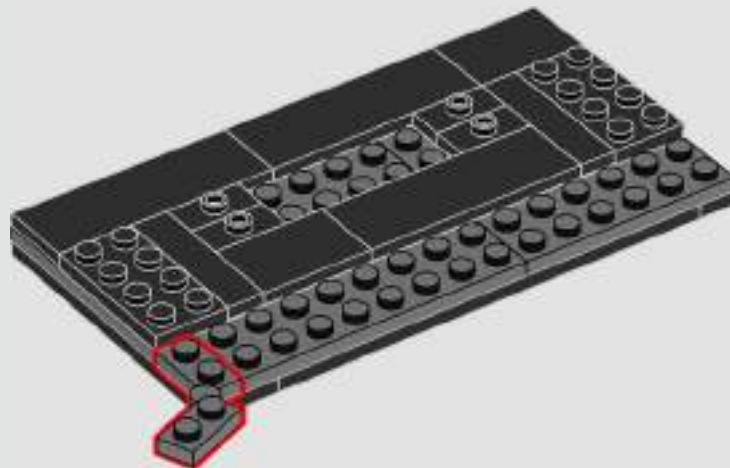

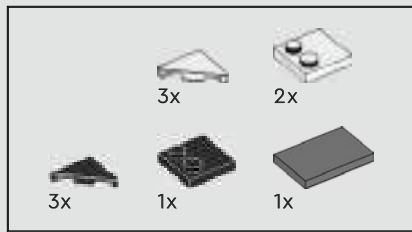

8

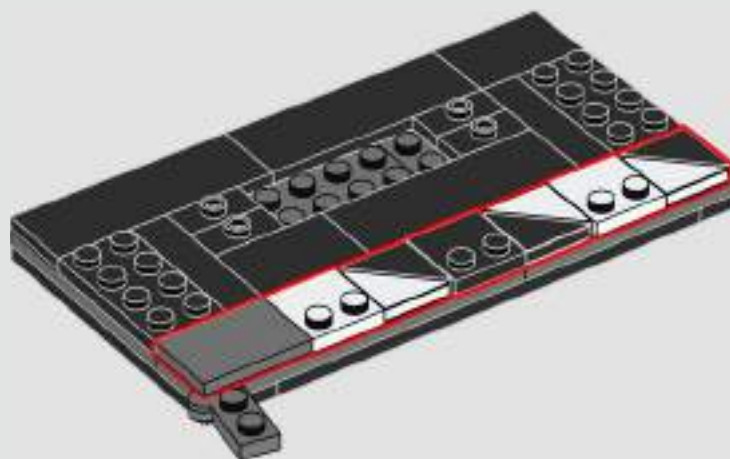

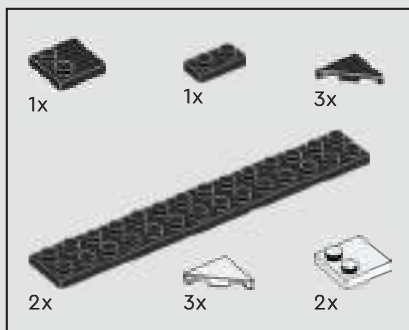

9

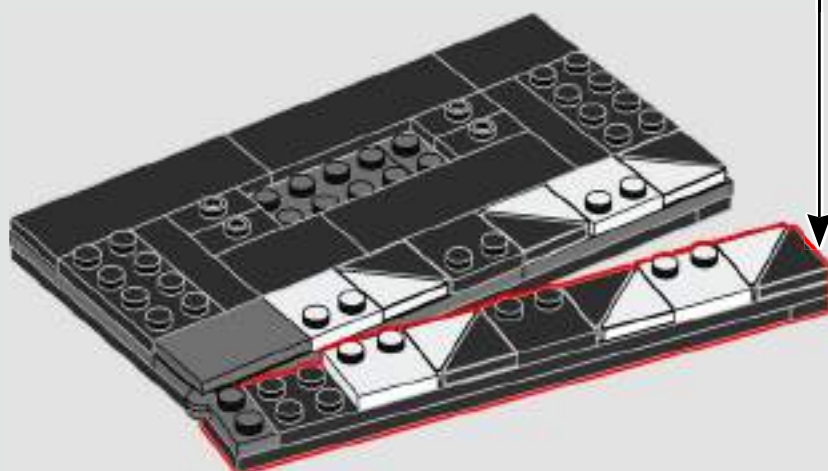
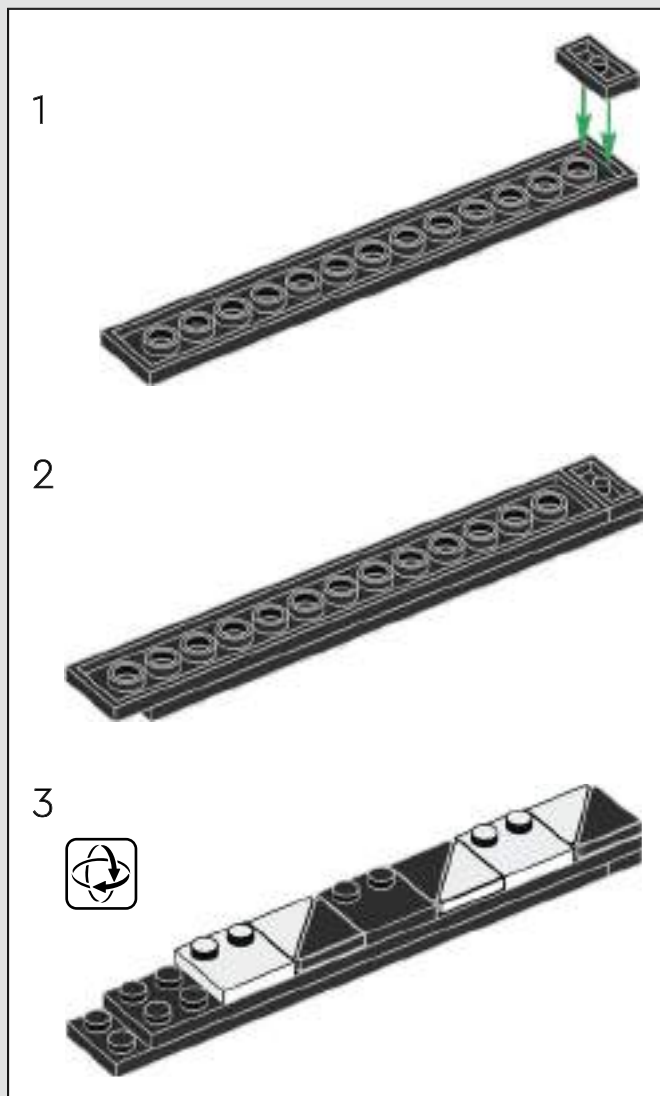

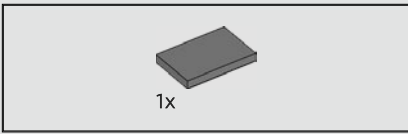

10

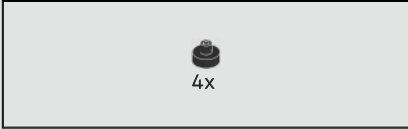
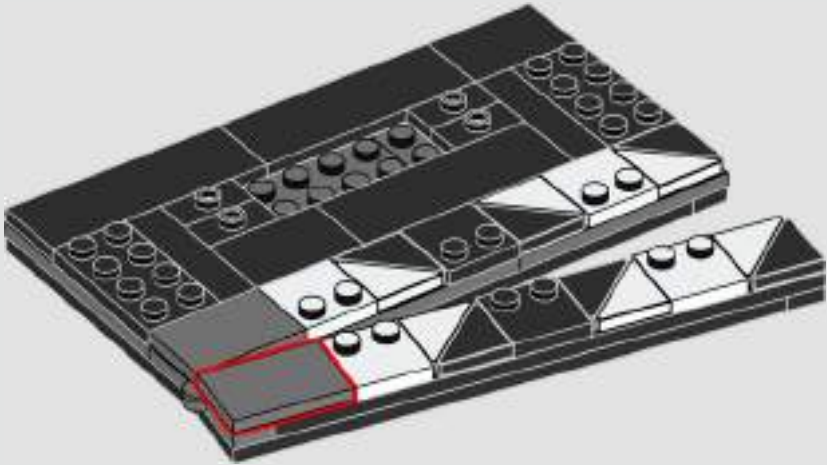

11

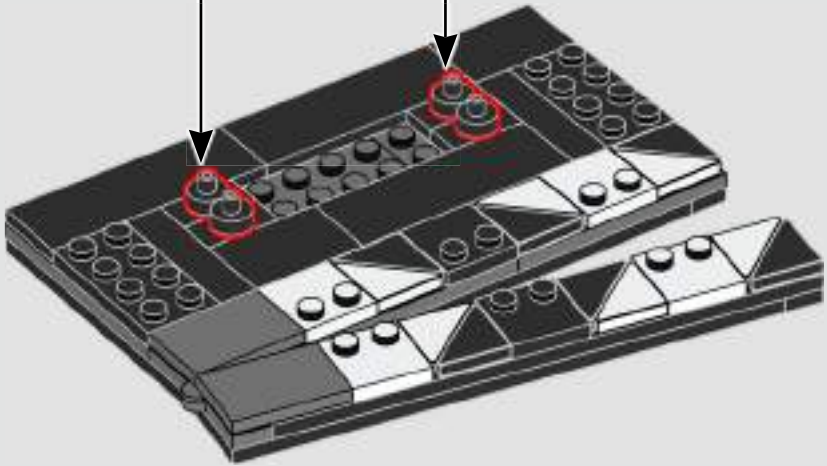

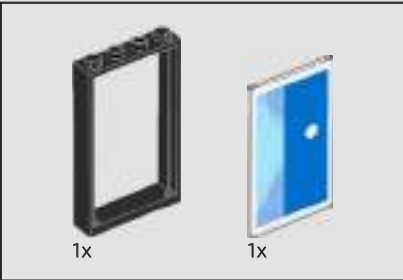

12

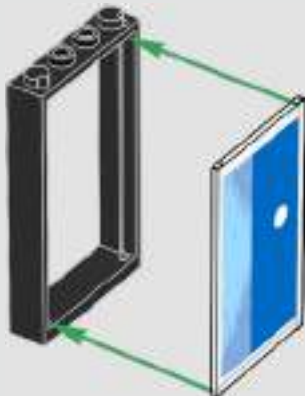

13

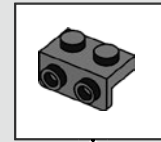

14

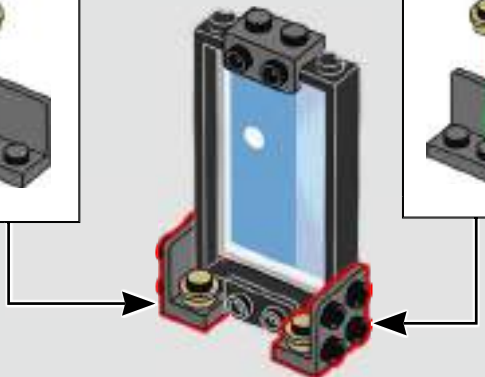
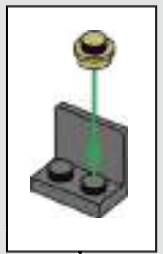
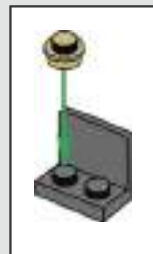
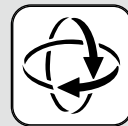



15

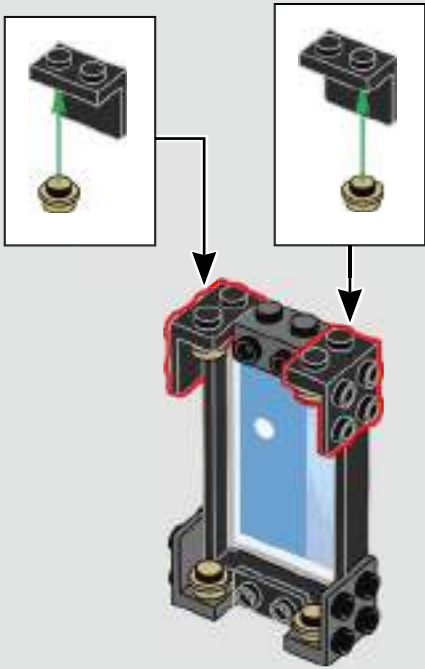

16

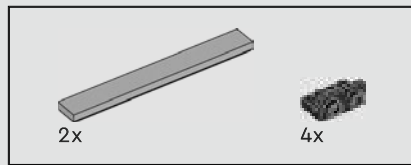
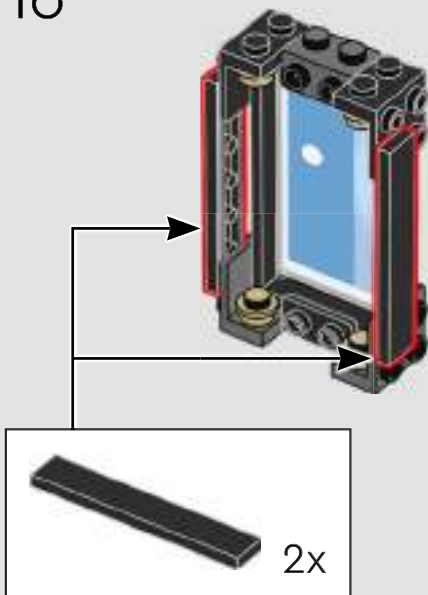

17

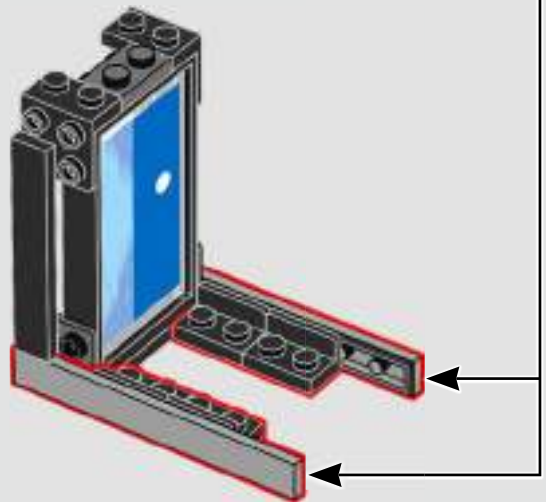
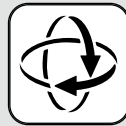
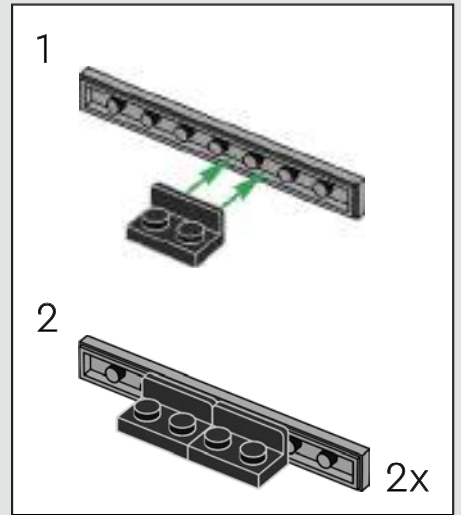



18

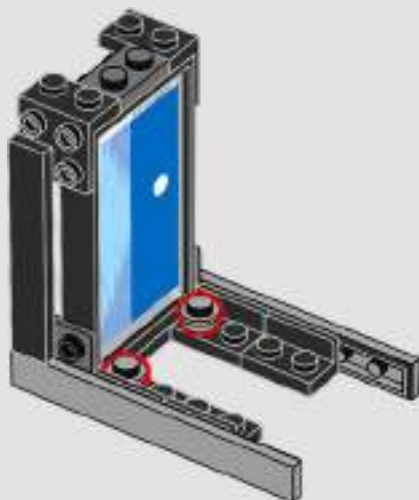

19

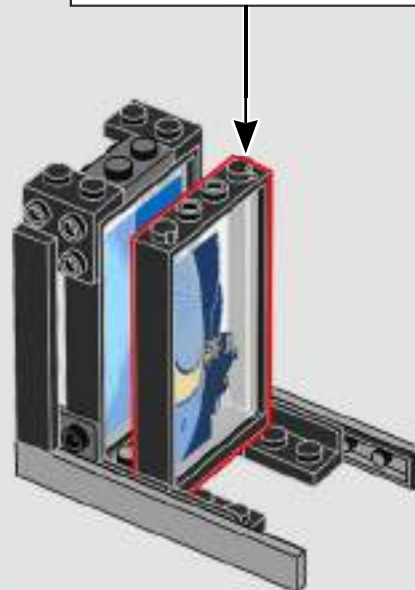
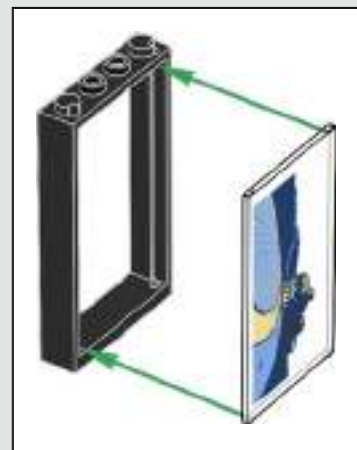



20



21

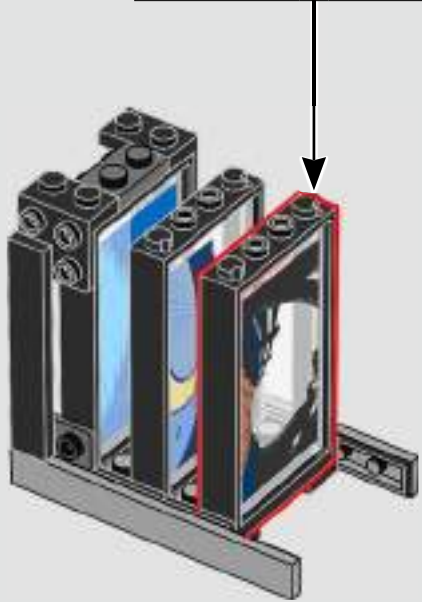
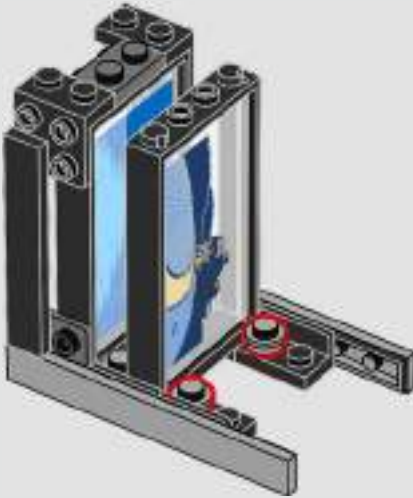
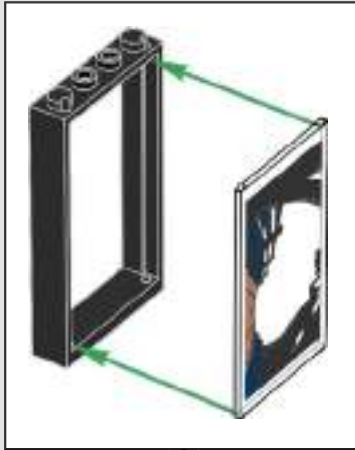





22

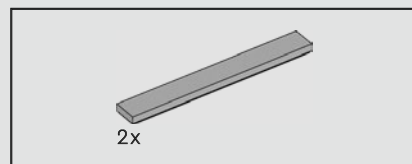
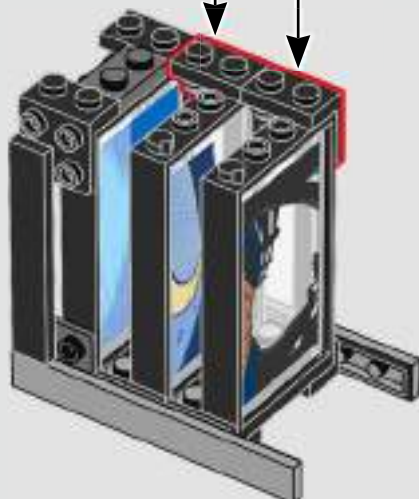
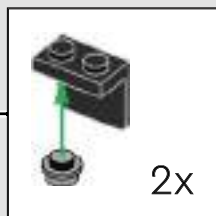

24

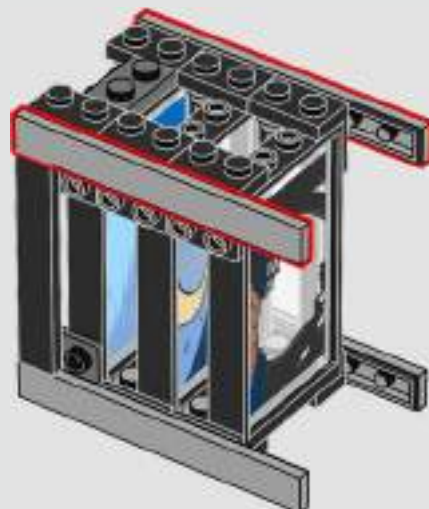

23

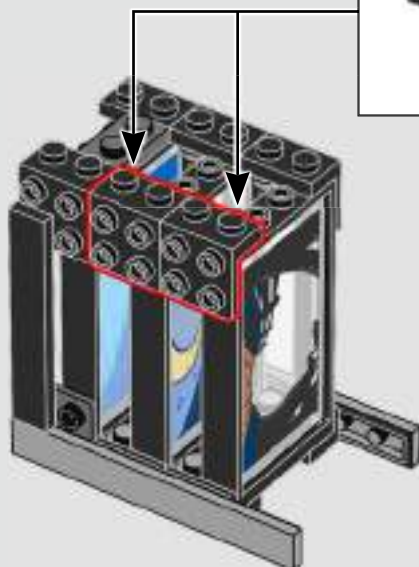
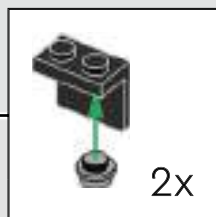

25

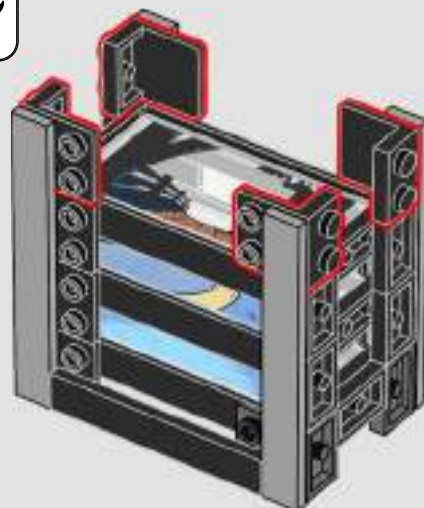

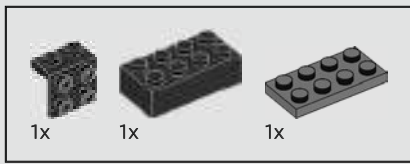

26

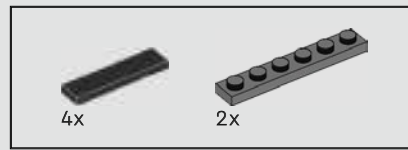
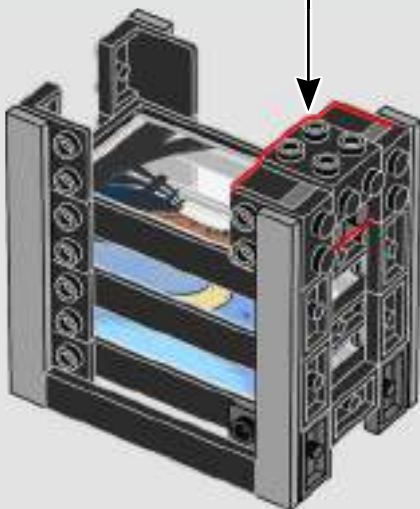
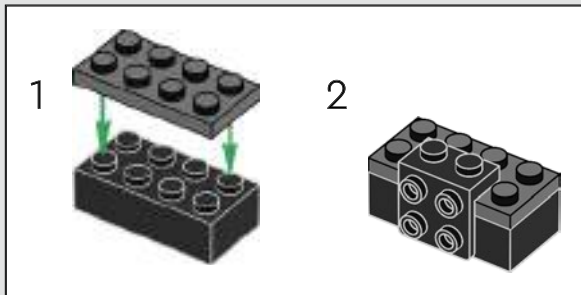

27

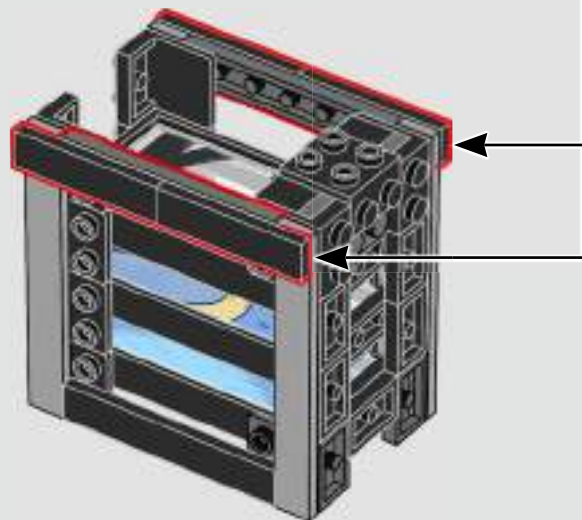
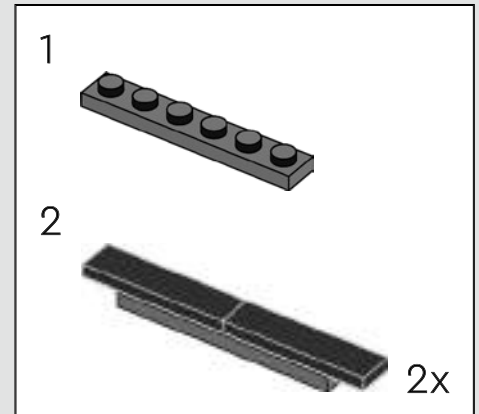



28

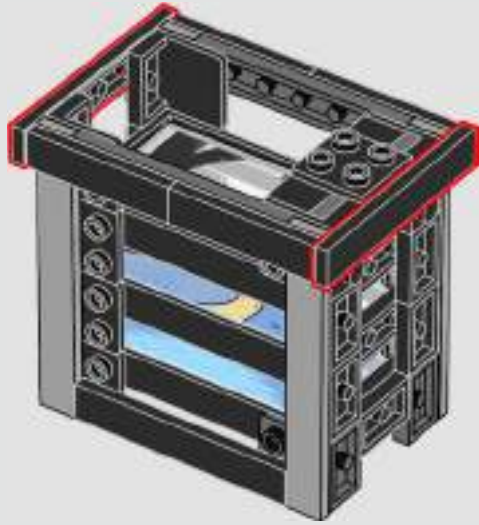

29

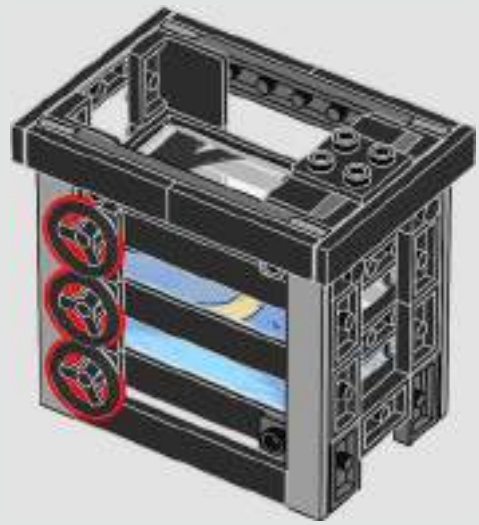

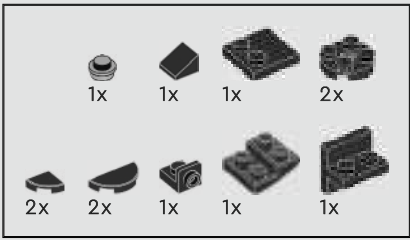

30

1



2



3



4



5



6



7

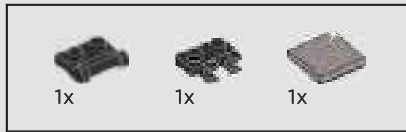
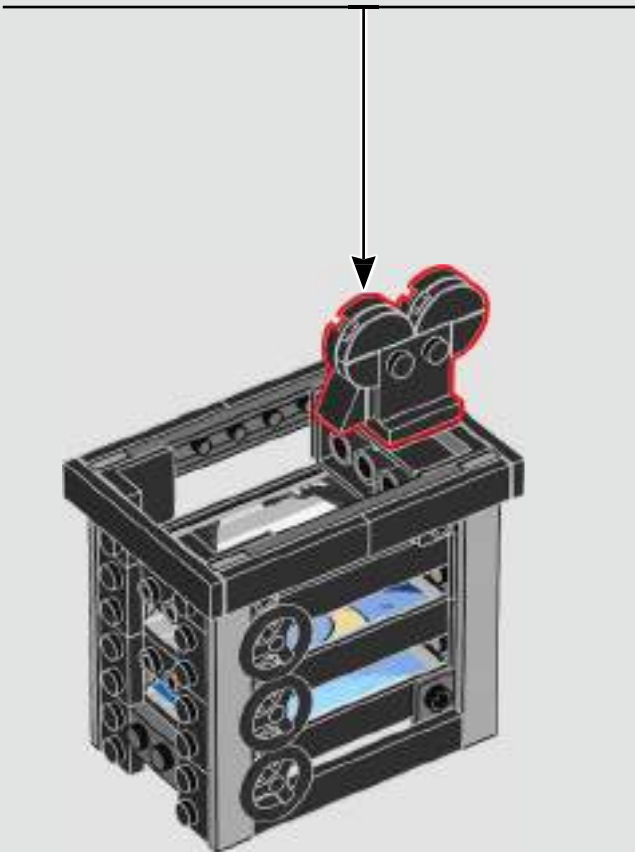

31

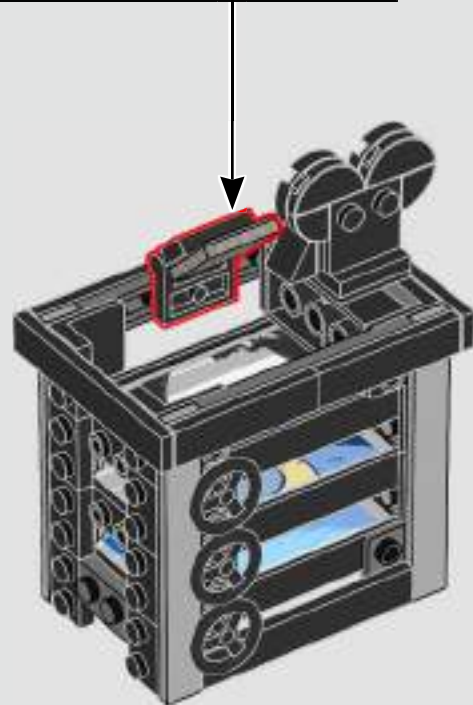
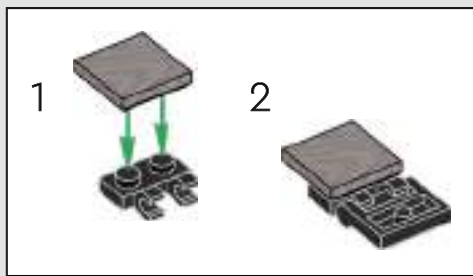

32

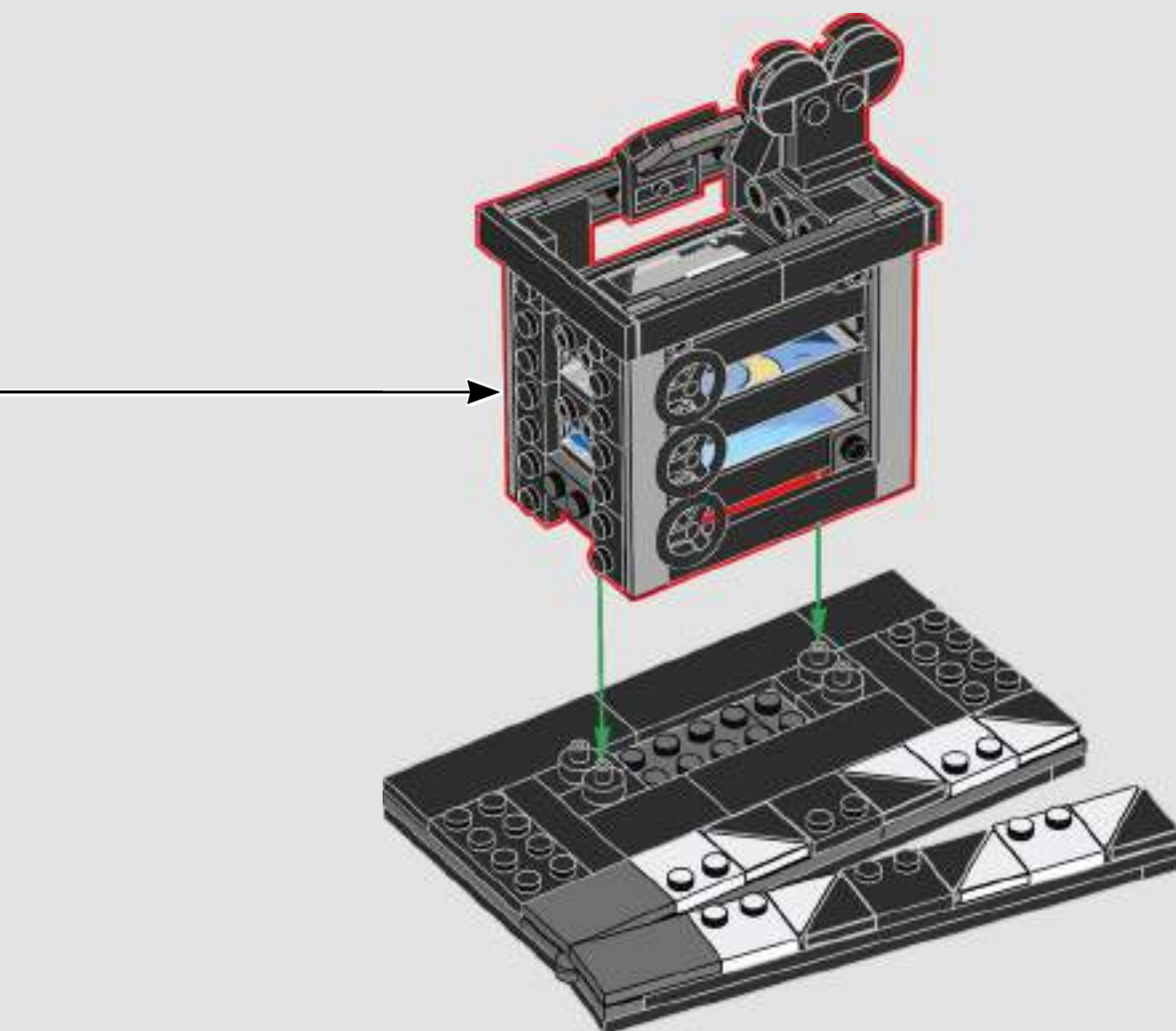

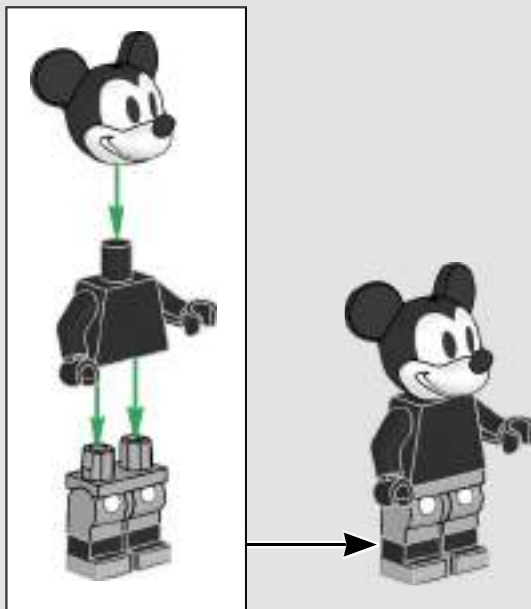



2

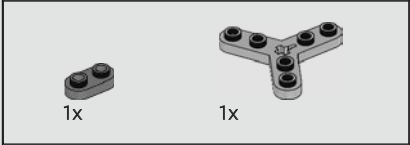

1





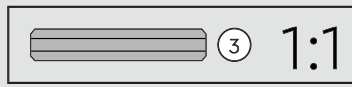

3

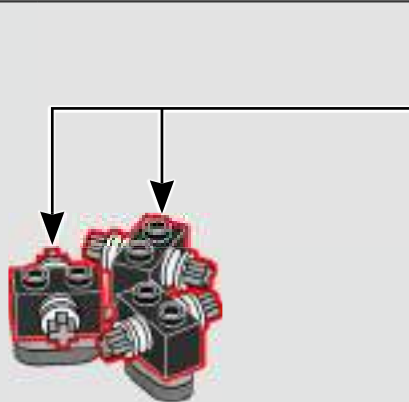
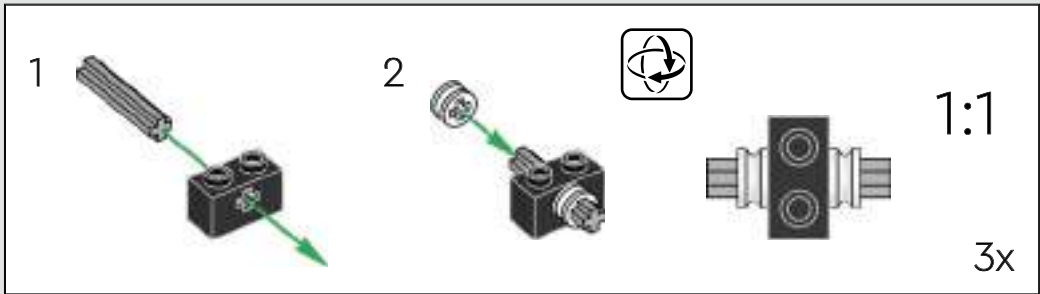

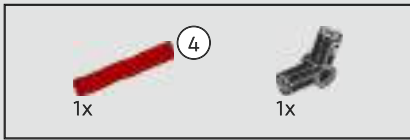

4

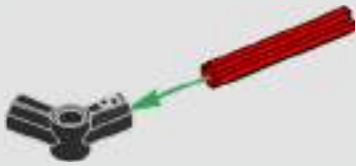

5

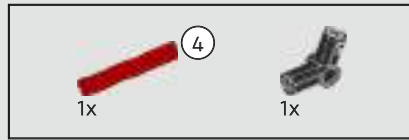
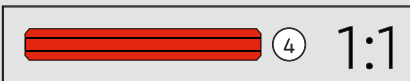
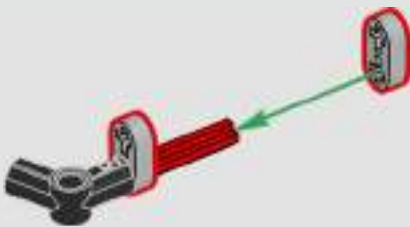

6

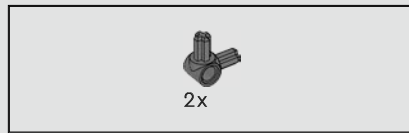
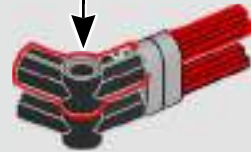
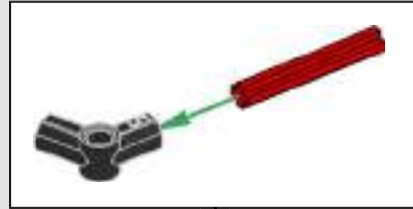

7

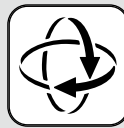

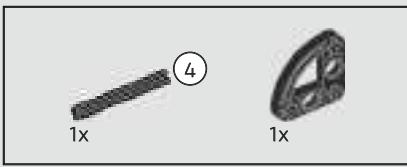

8

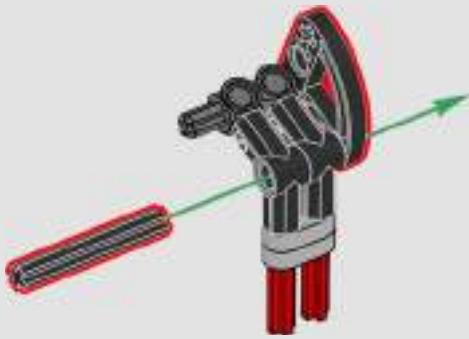

10

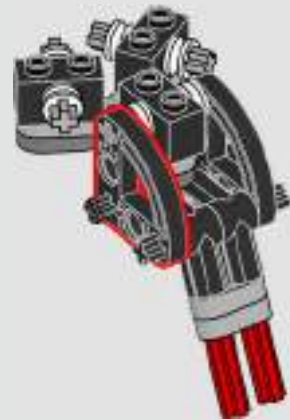

9



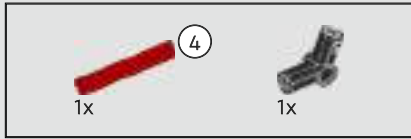

11

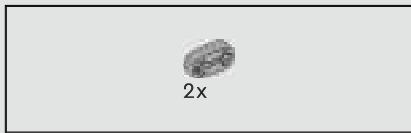

12

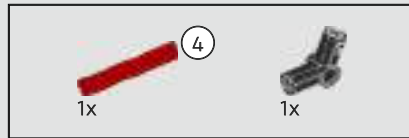
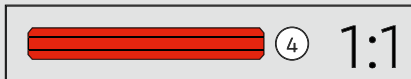
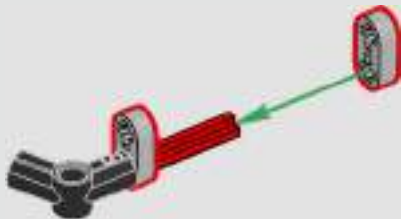

13

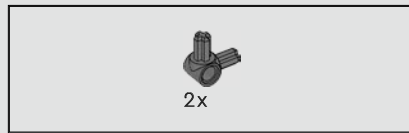
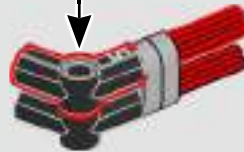
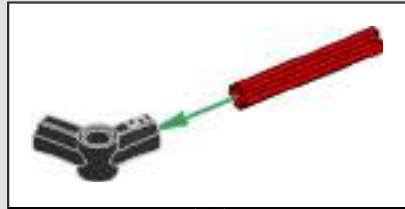

14

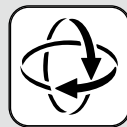

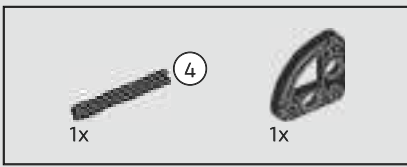

15

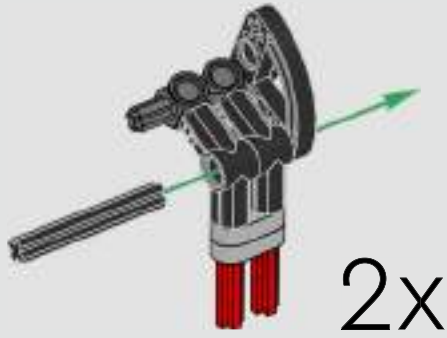

17

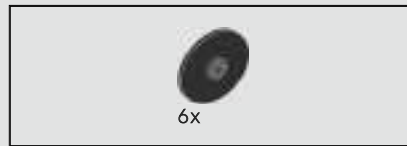
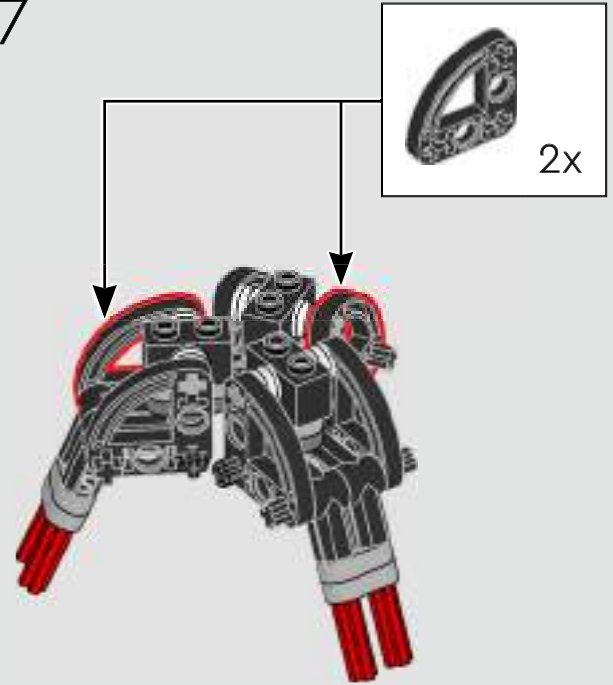

18

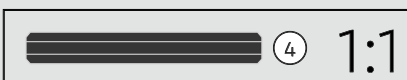
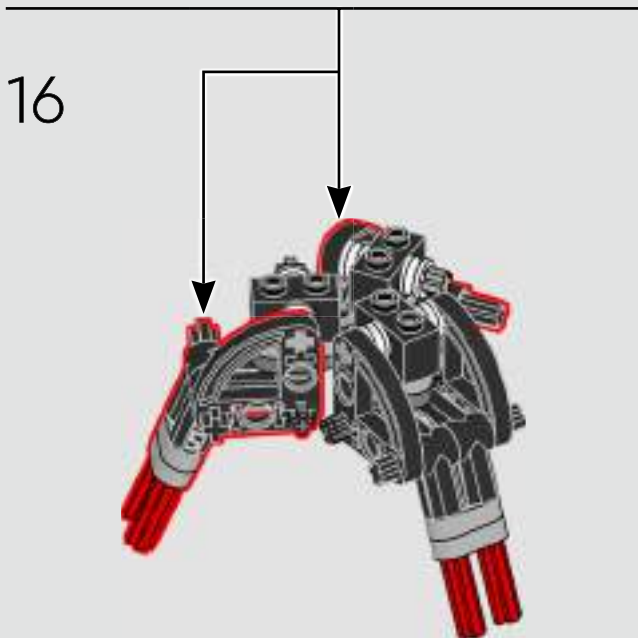
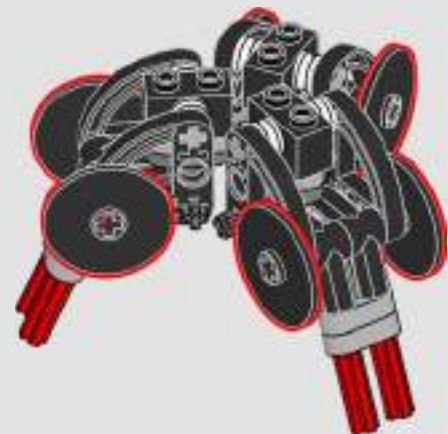

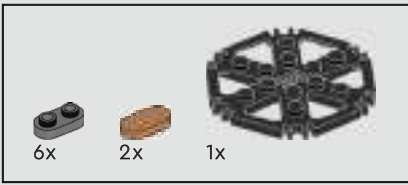

19

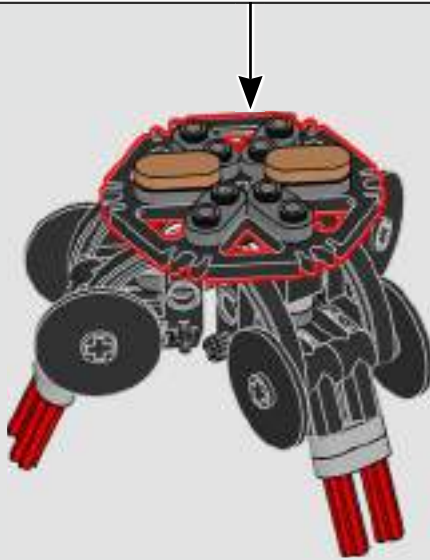
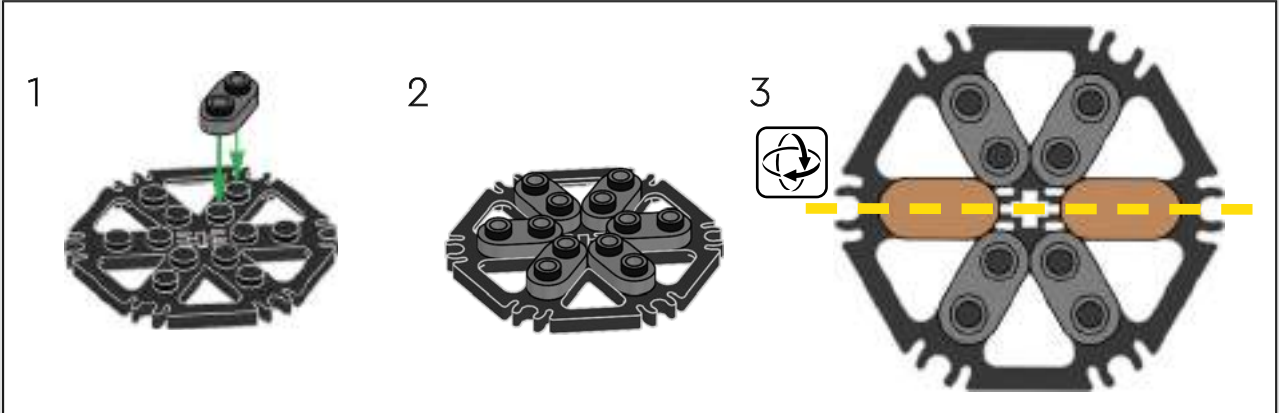
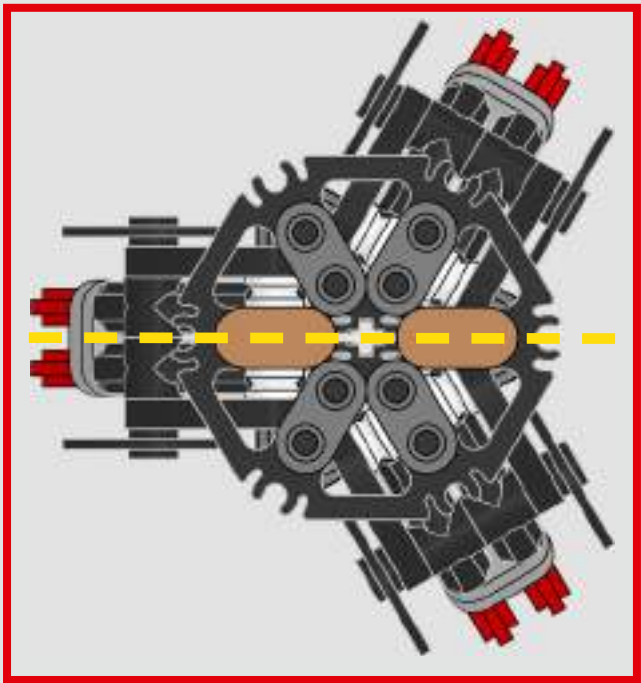

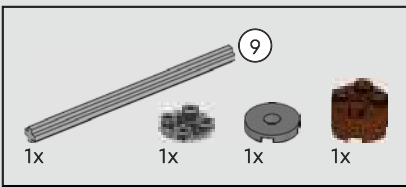

20

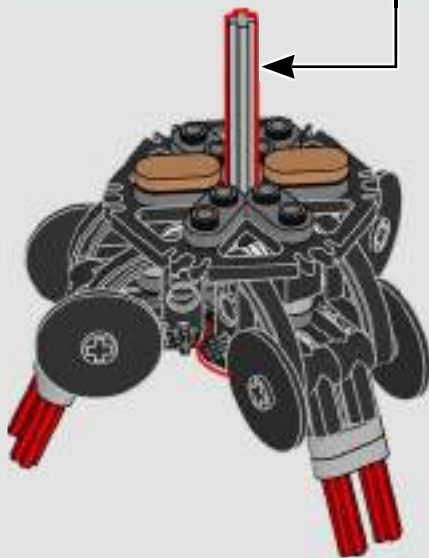
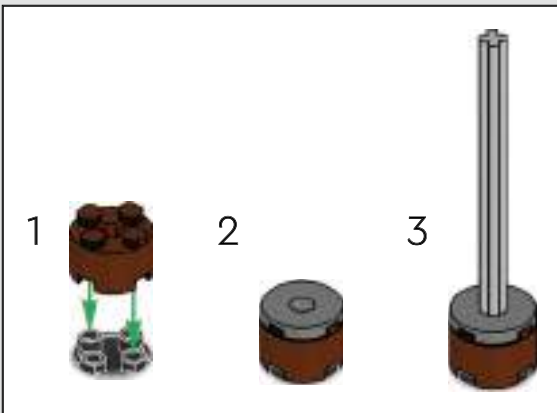

21

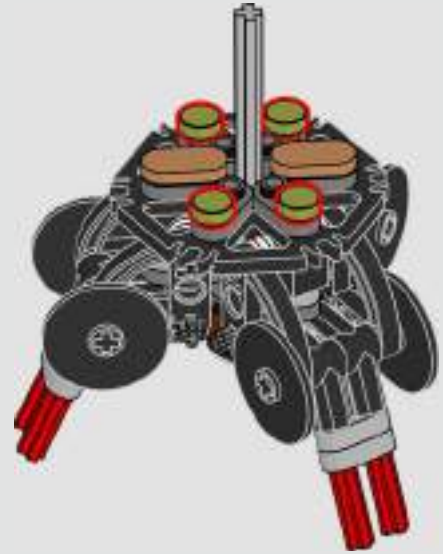

22

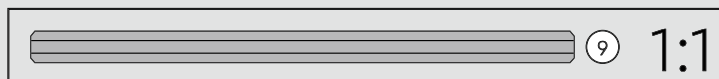
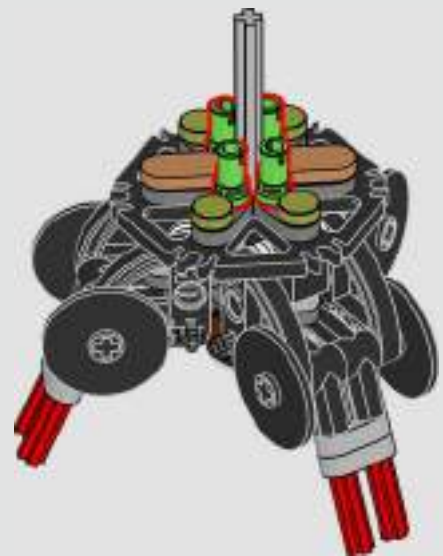

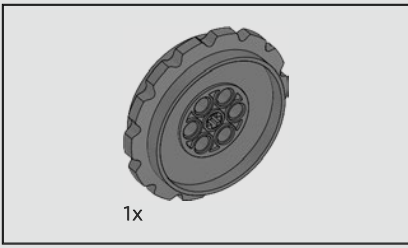

23

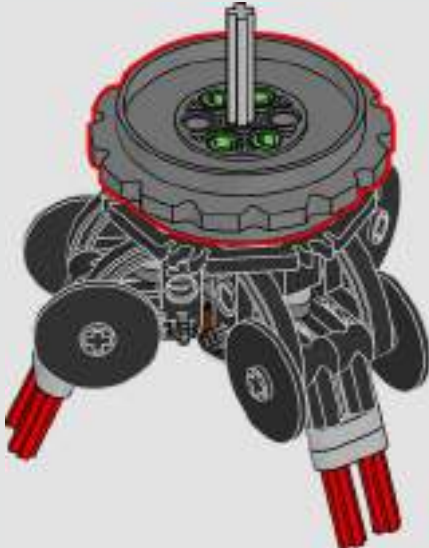
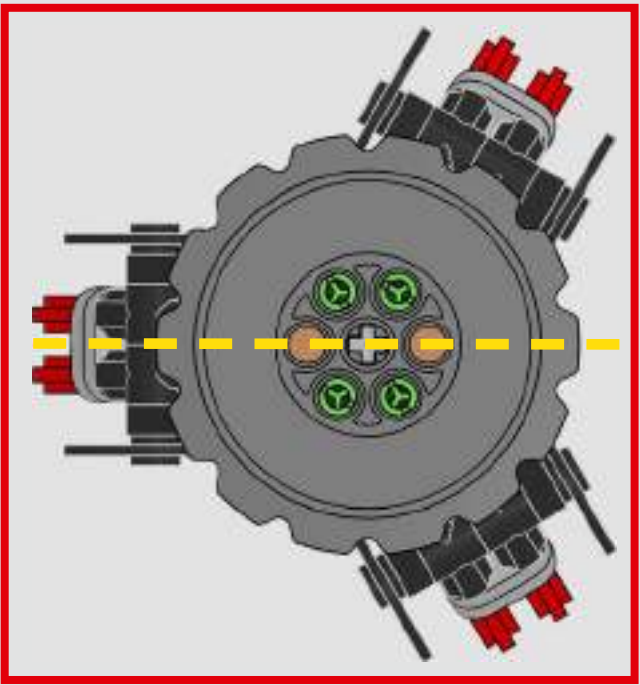





24

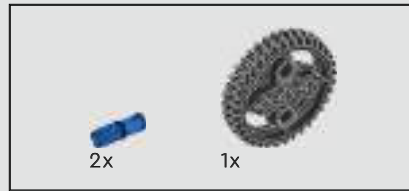
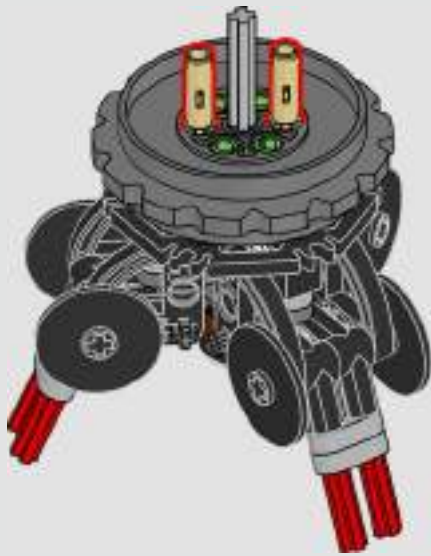

25

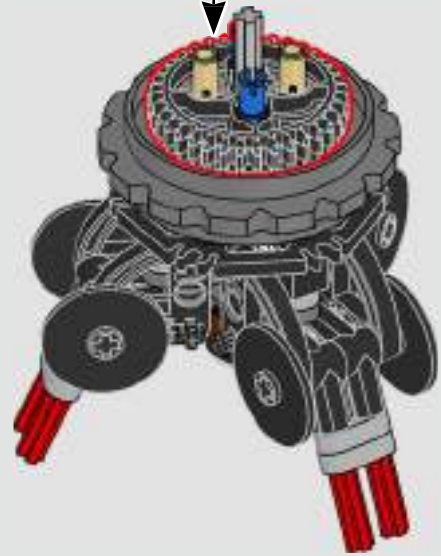

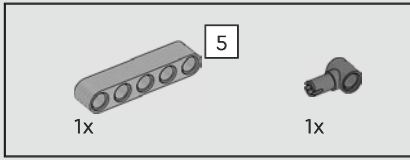

26

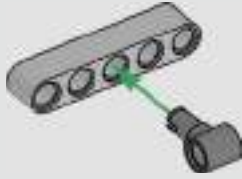

27

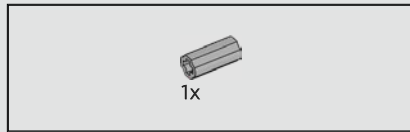
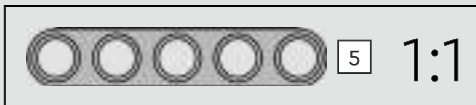
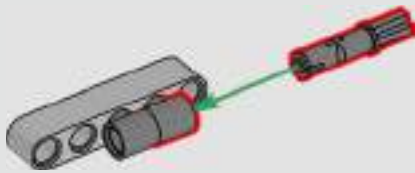

28

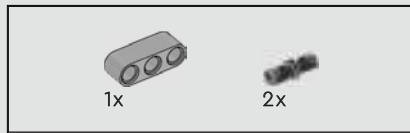
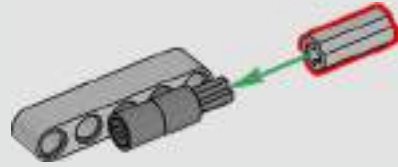

29

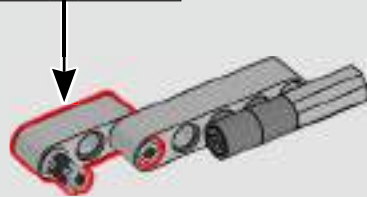

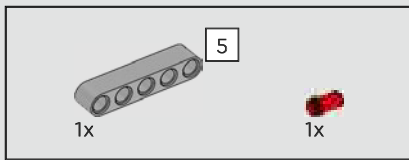

30

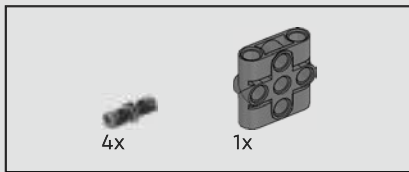
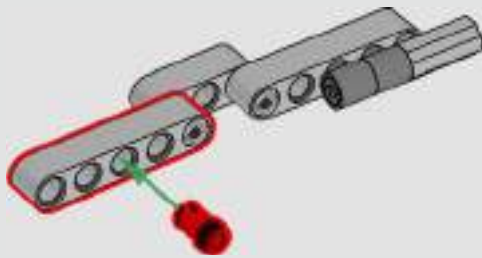

31

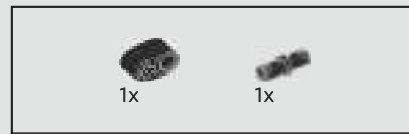
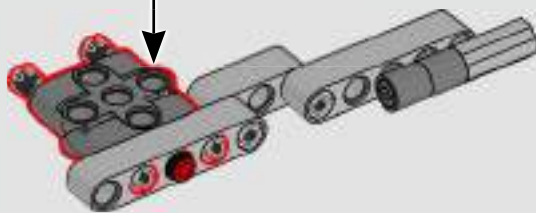
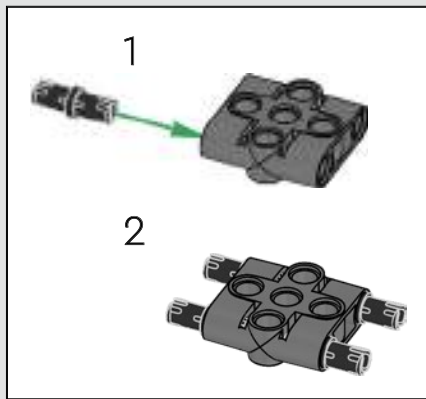

32

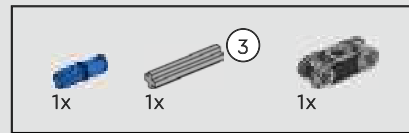
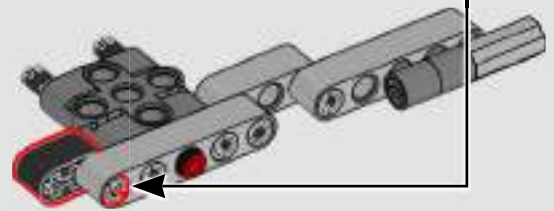

33

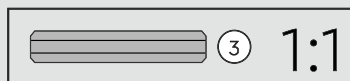
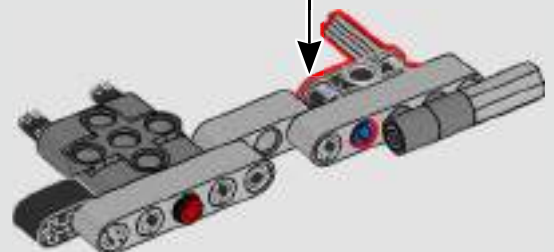

34

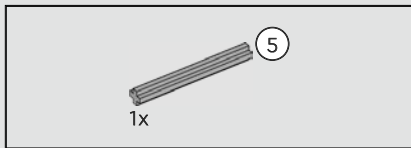
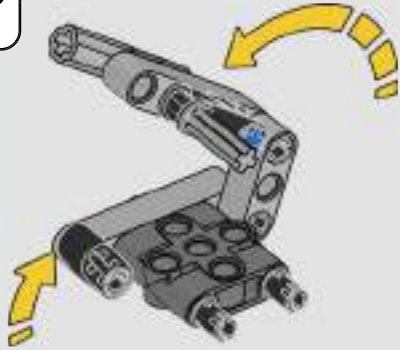

35

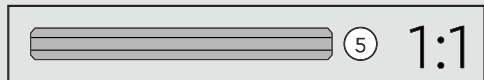
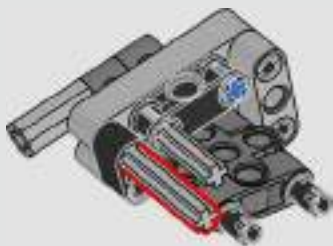

36

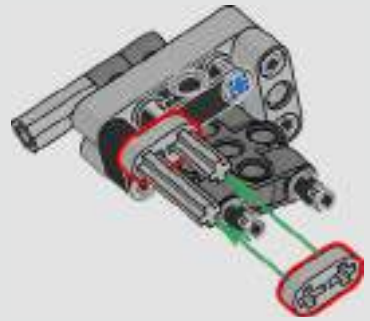

37

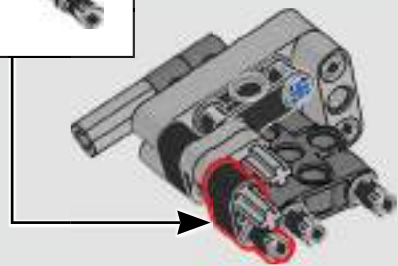

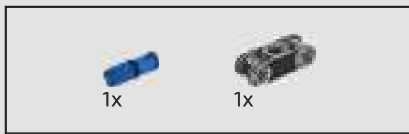

38

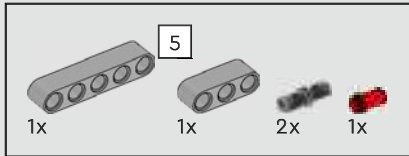
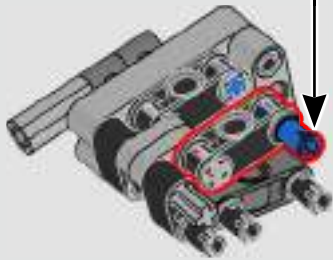
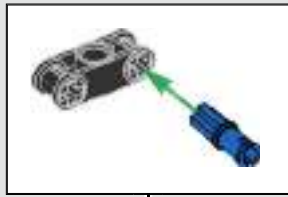

39

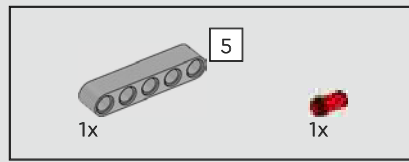
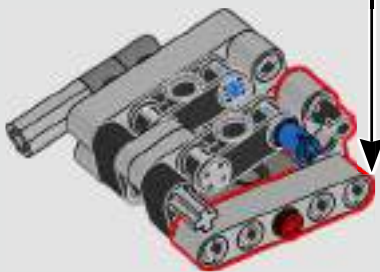
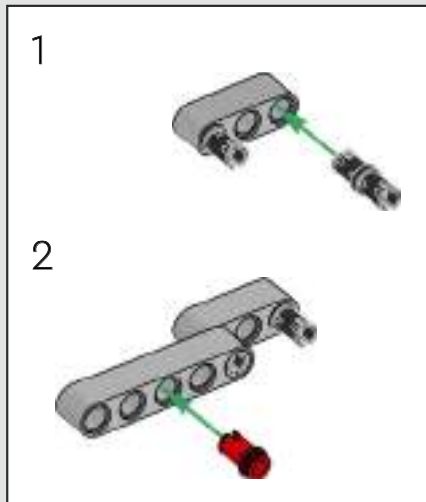

40

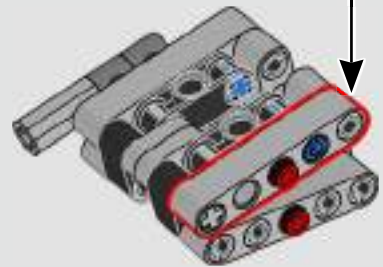
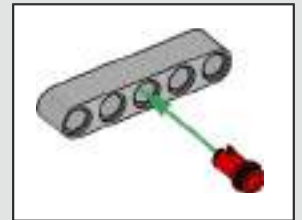

41

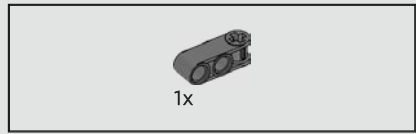
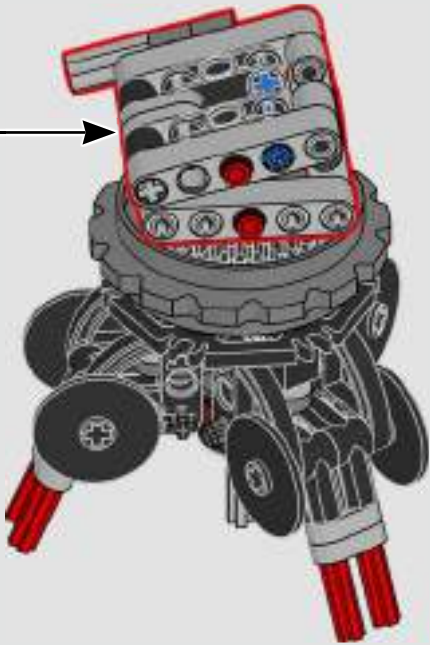

42

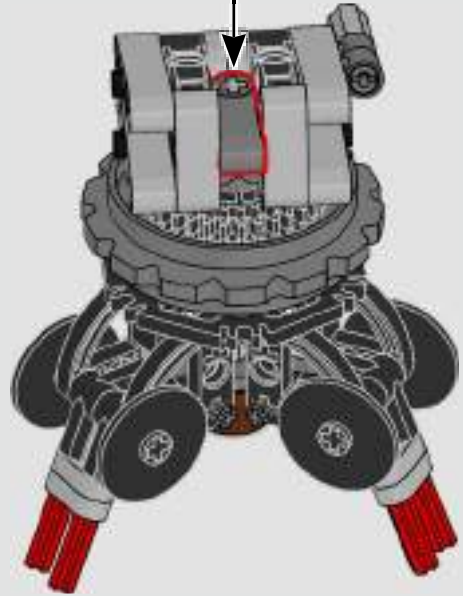
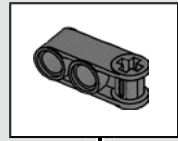

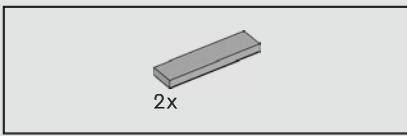

43

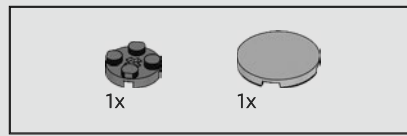
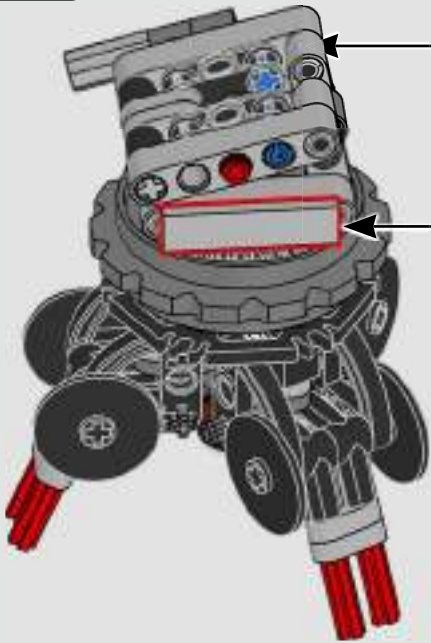
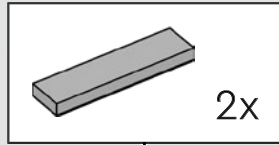

44

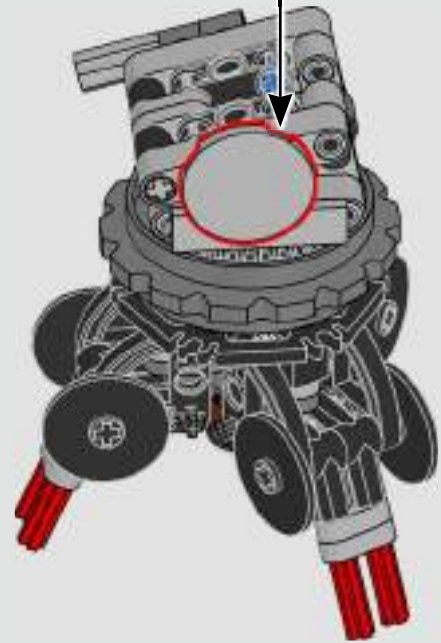
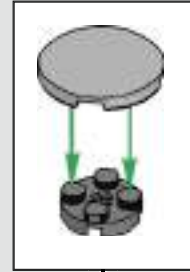

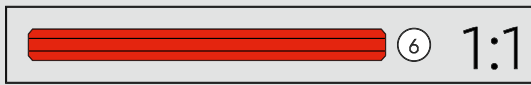
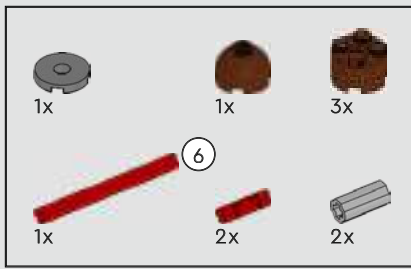

45

1

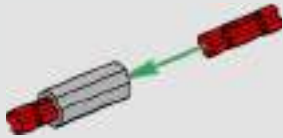

2

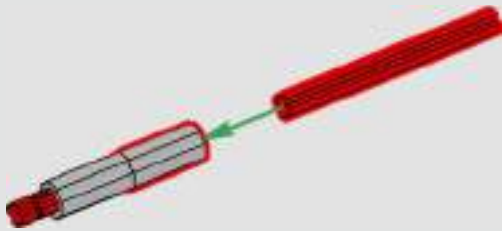

3

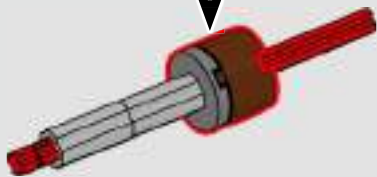

4

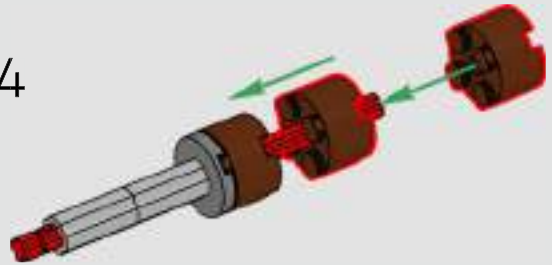

5

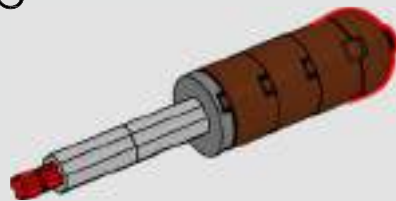



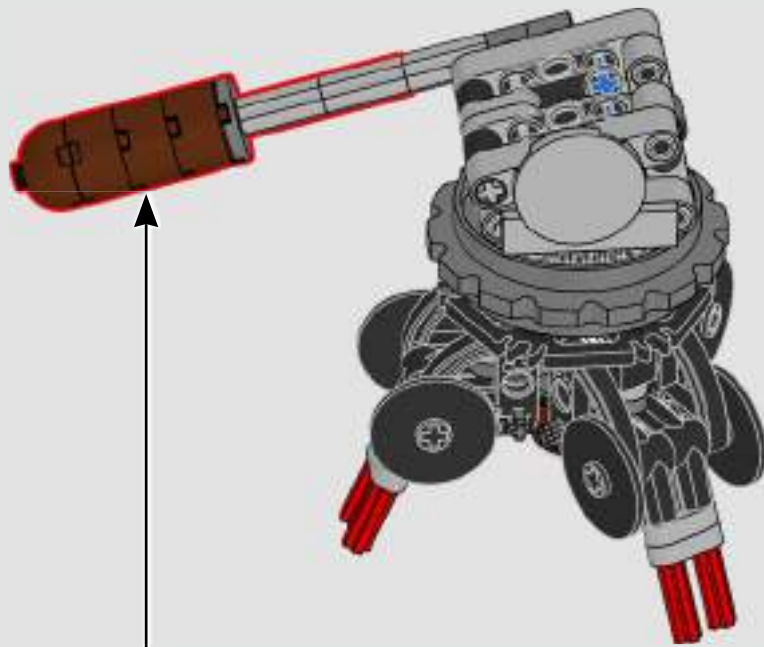



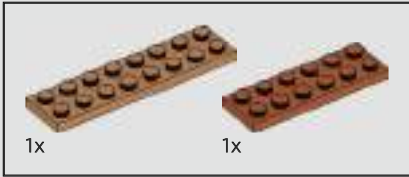

46

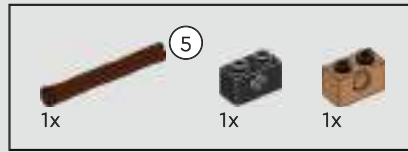
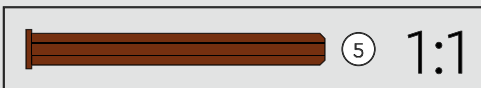
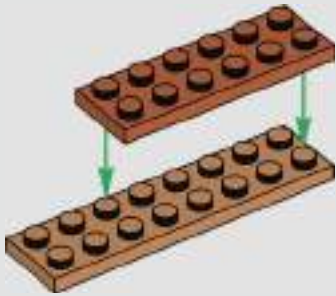

47

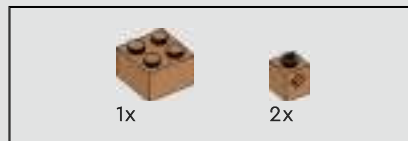
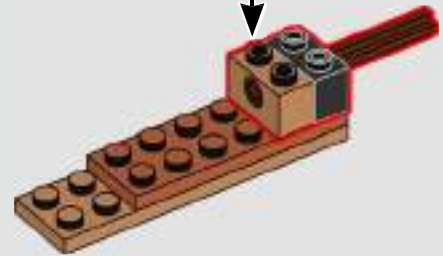
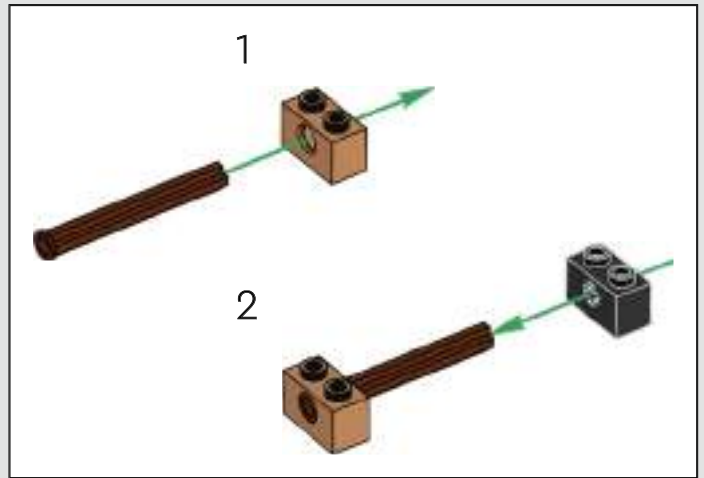

48

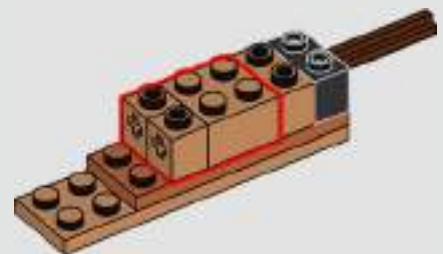

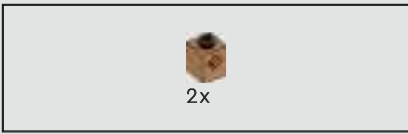

49

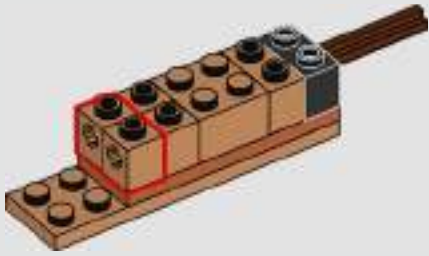

51

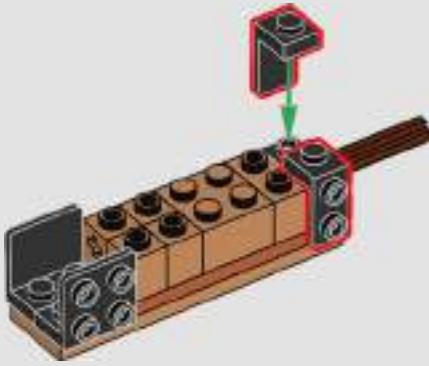

50

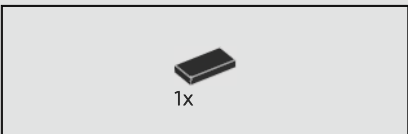
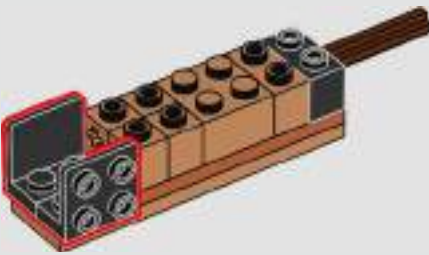

52

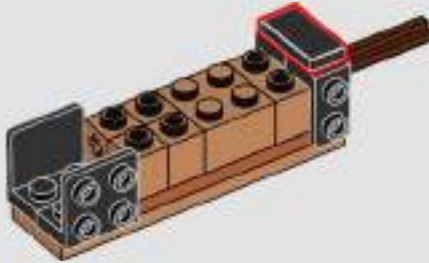

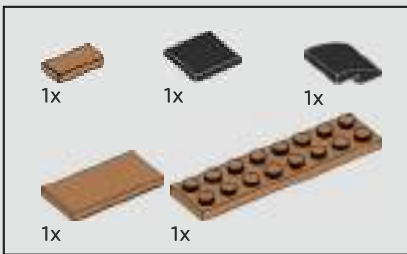

53

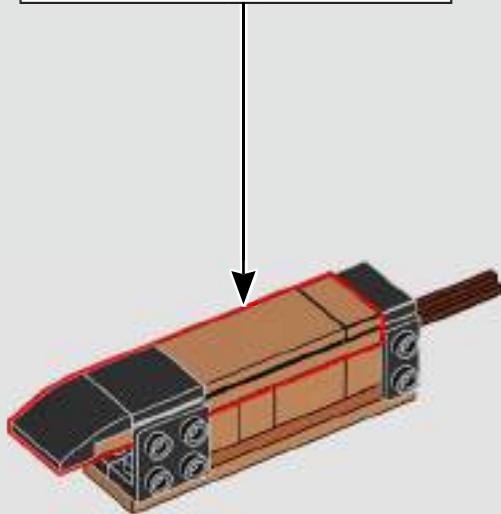
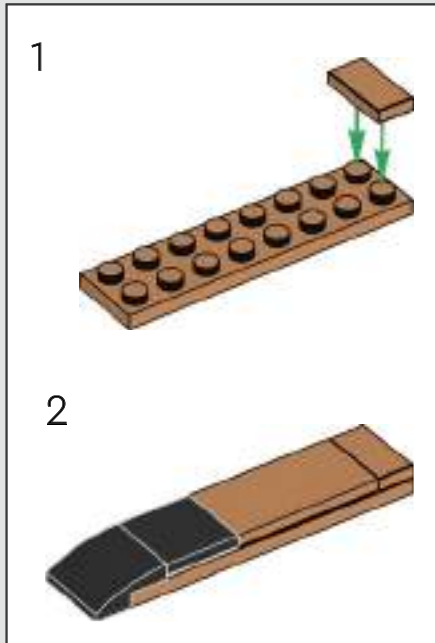

54

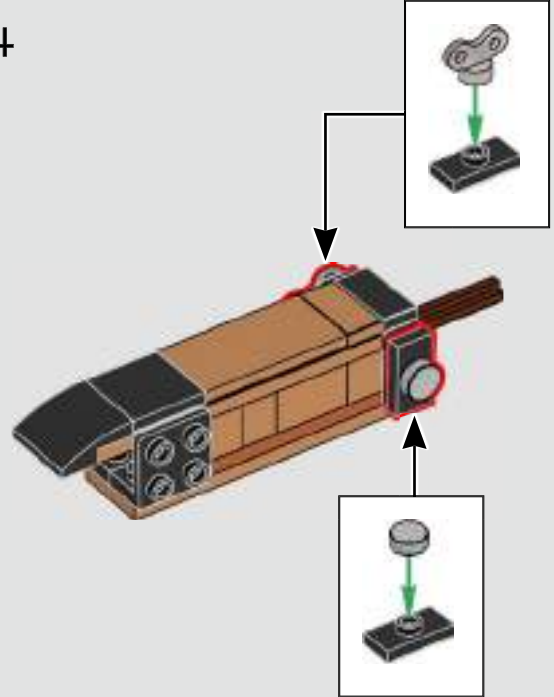

55

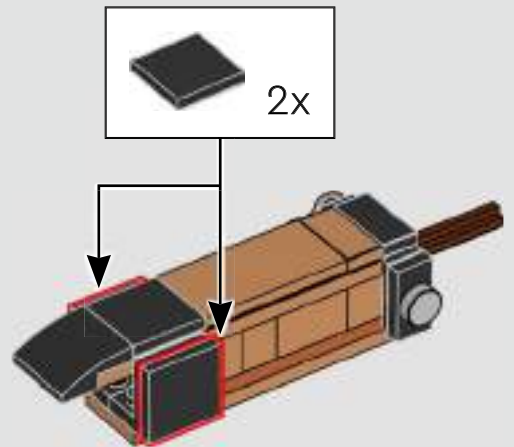

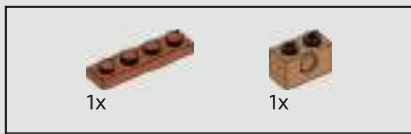

56

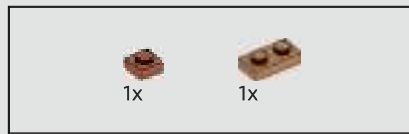
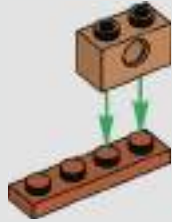

58

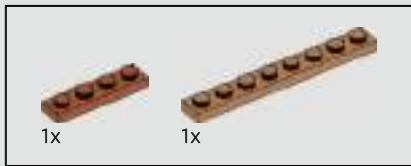
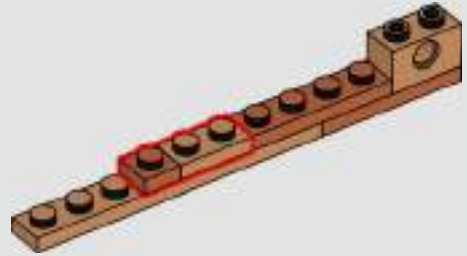

57

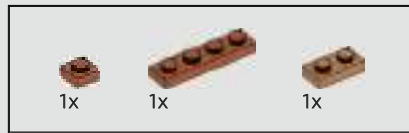
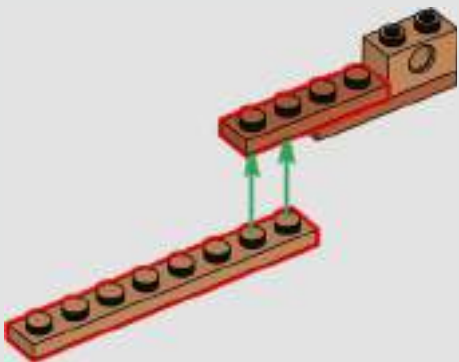

59

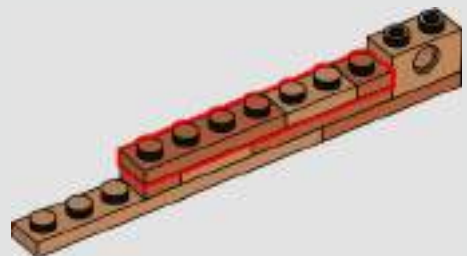

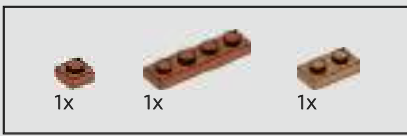

60

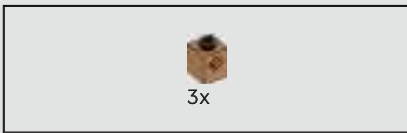
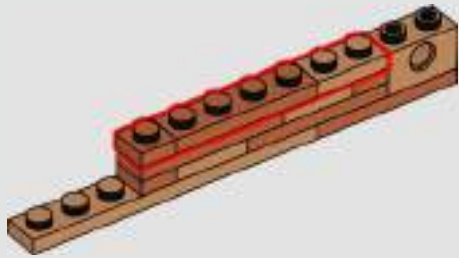

61

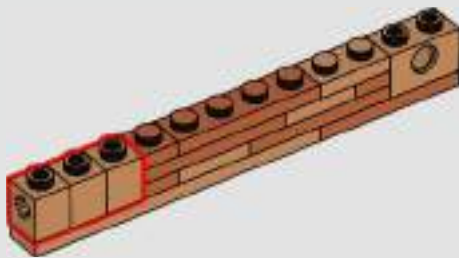

62

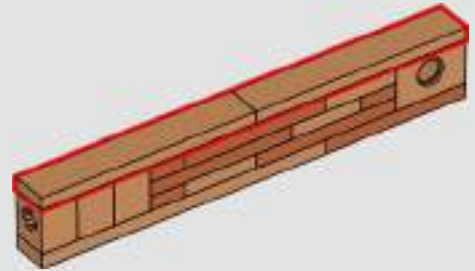

63

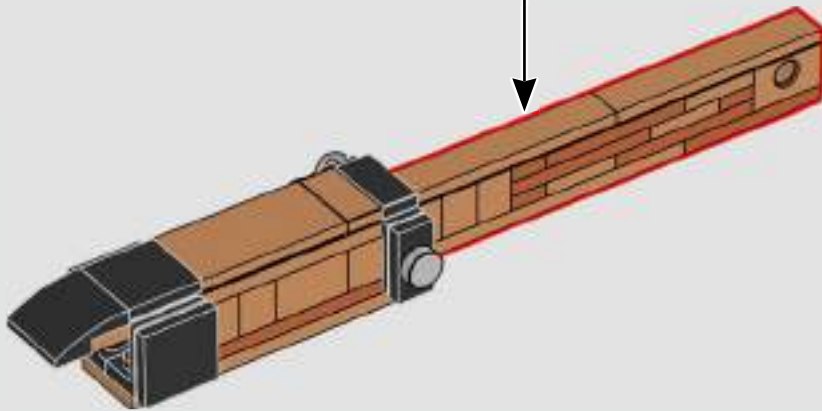

3x





64

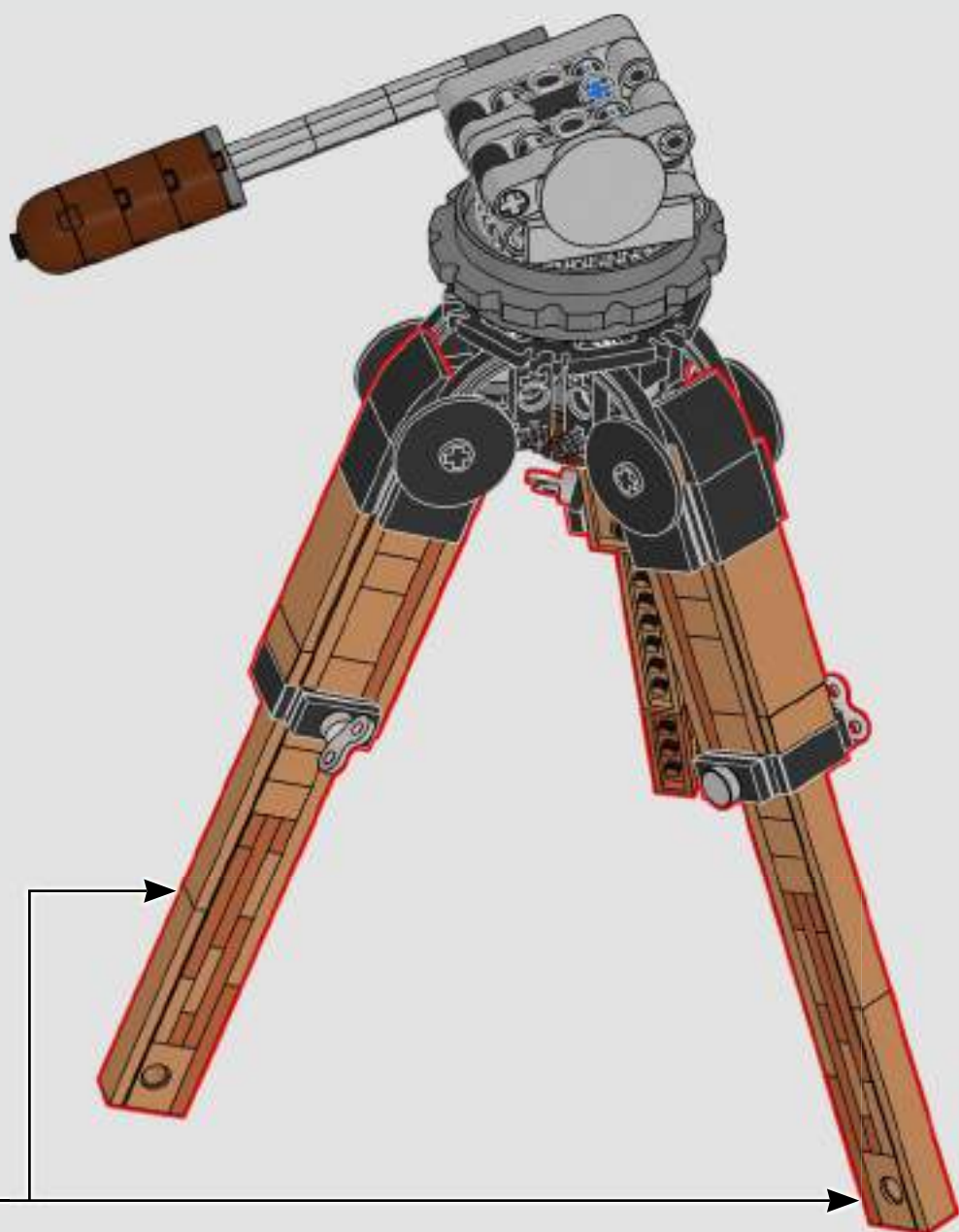

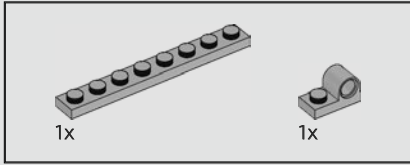
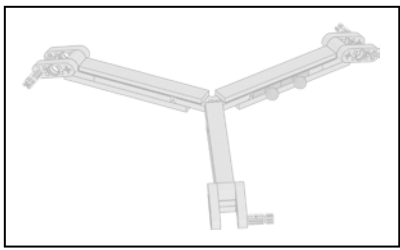

65

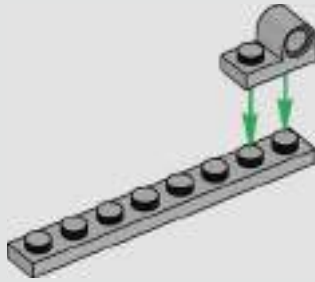

66

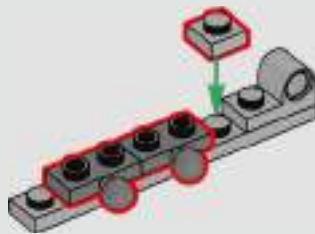

67

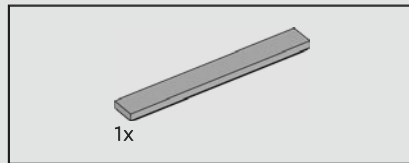
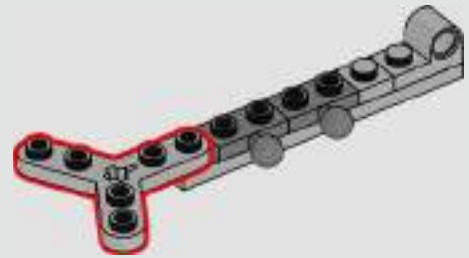

68

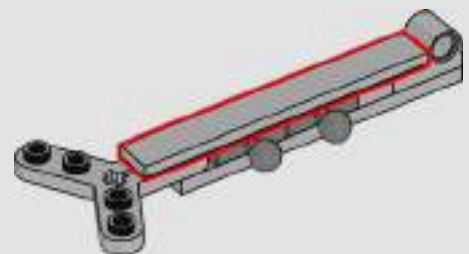

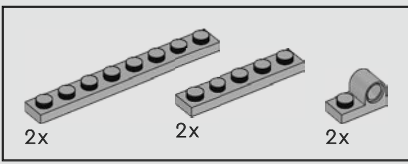

69

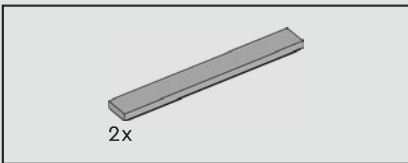
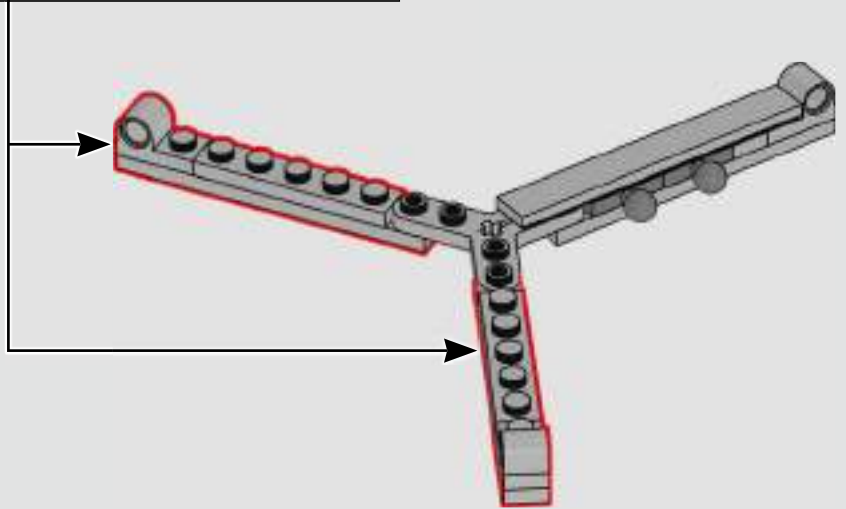
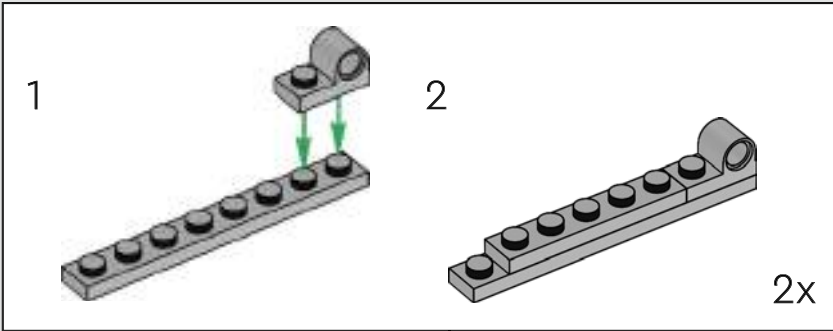

70

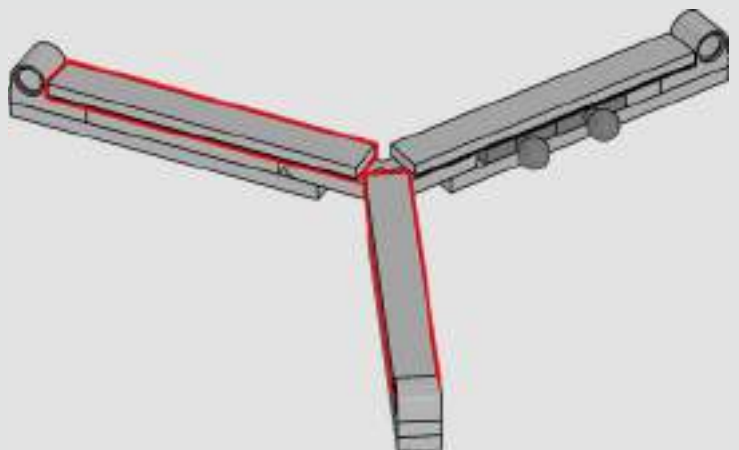

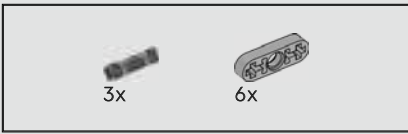

71

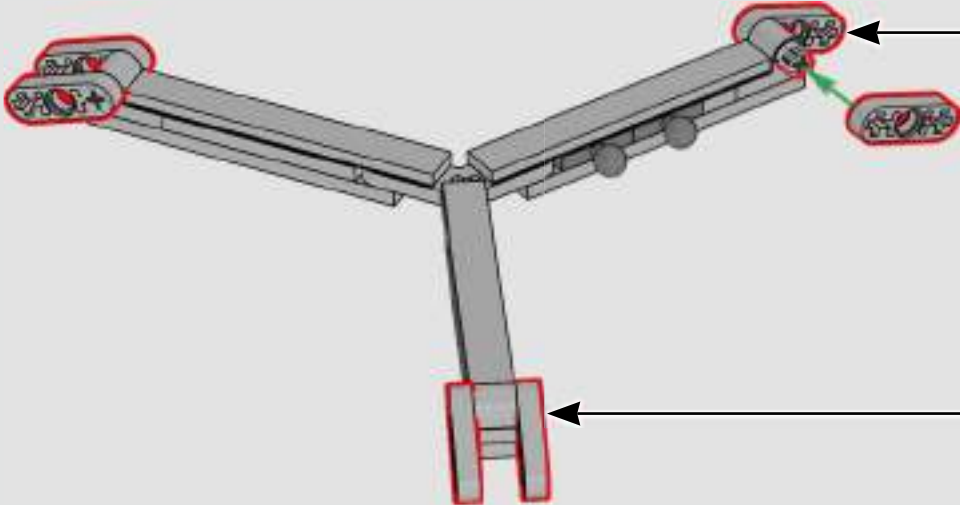
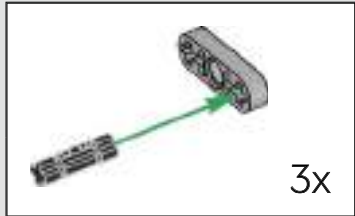

72

