

Стол журнальный АСТИ / Coffee table ASTI

Код ТН ВЭД ЕАЭС

9403 60 100 1
9403 90 300 0



отрезать
и приклеить

Паспорт изделия

500	470	450

000000 / 0000

max
15 KG

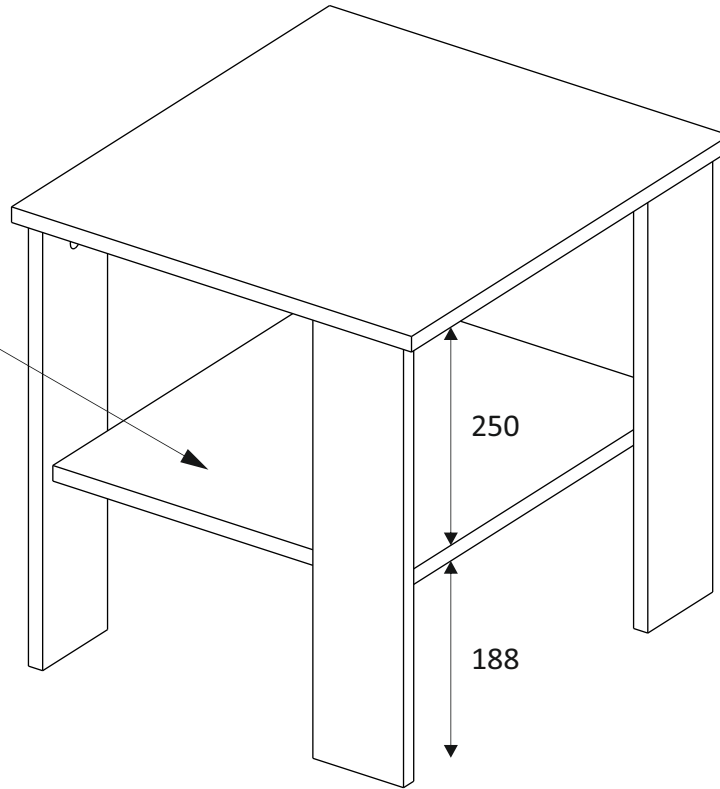





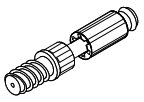

Комплектовочная ведомость / Set package sheet

Упак/ Package	Наименование	Description	Цвет детали/ Décor					Размер / Size, mm	Кол-во/ Quantity	№
			White	Beton	Wenge	Craft gold	Sonoma			
1	Крыша	Top	White	Beton	Wenge	Craft gold	Sonoma	450x500	1	2
	Бок	Side	White	Beton	Wenge	Craft gold	Sonoma	454x102	4	1
	Фурнитура	Furniture/Cabinetry hardware	-	-	-	-	-	-	1	-
	Вязка	Connecting element	White	Beton	Wenge	Craft gold	Sonoma	454x390	1	3

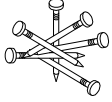
Упак/ Package	Наименование	Description	Цвет детали/ Décor				Размер / Size, mm	Кол-во/ Quantity	№
			Beton-White	Wenge-White	Craft gold-White	Sonoma-White			
1	Крыша	Top	Beton	Wenge	Craft gold	Sonoma	450x500	1	2
	Бок	Side	White	White	White	White	454x102	4	1
	Фурнитура	Furniture/Cabinetry hardware	-	-	-	-	-	1	-
	Вязка	Connecting element	Beton	Wenge	Craft gold	Sonoma	454x390	1	3

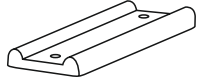
2

1	2	48	2x20	73	76
					
8 x	8 x	8 x	8 x	4 x	

15

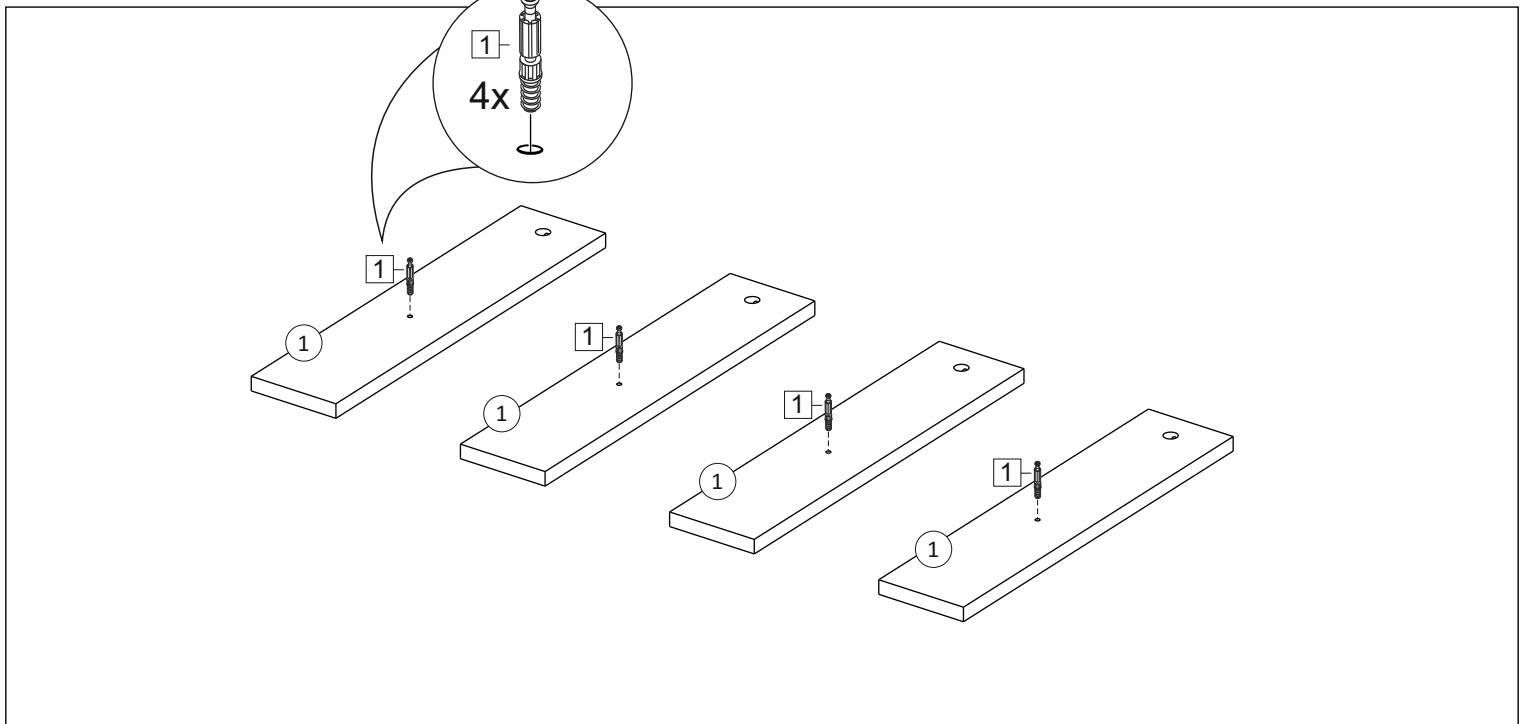
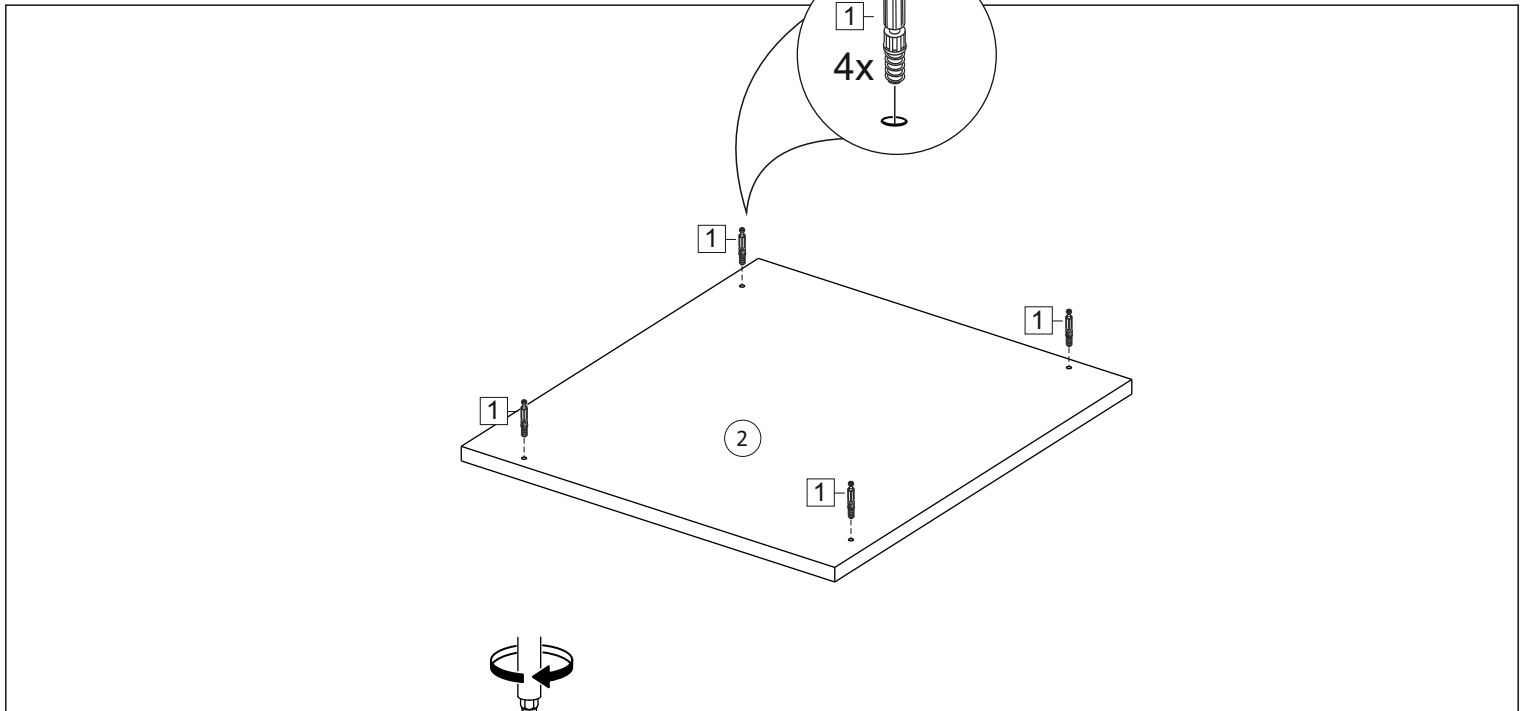
1 x

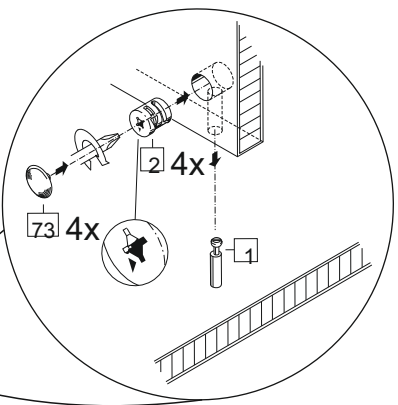
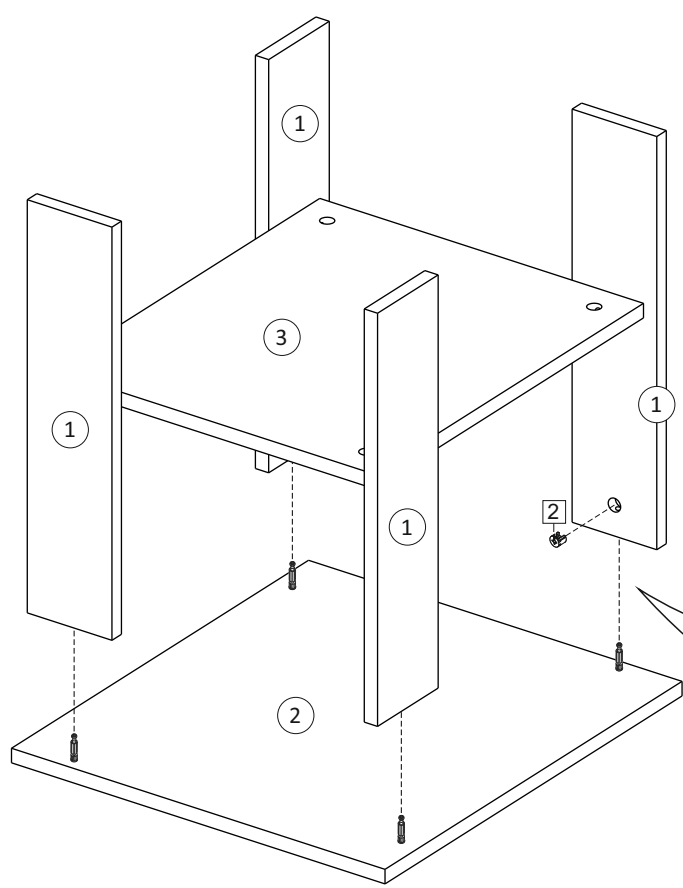
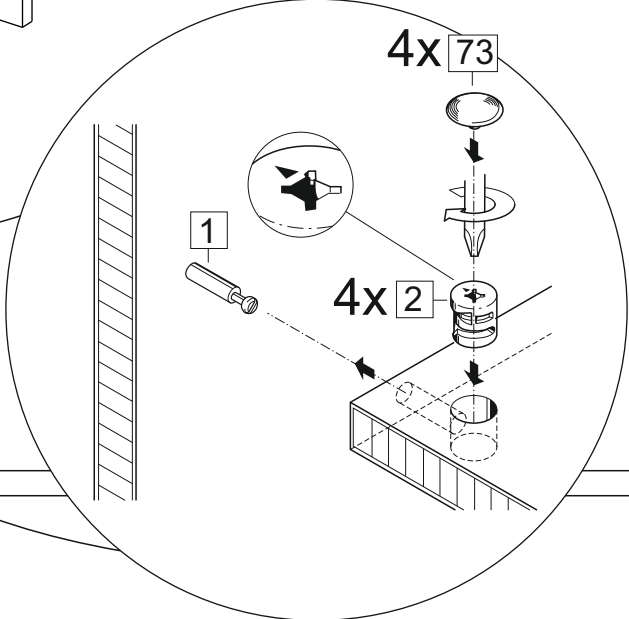
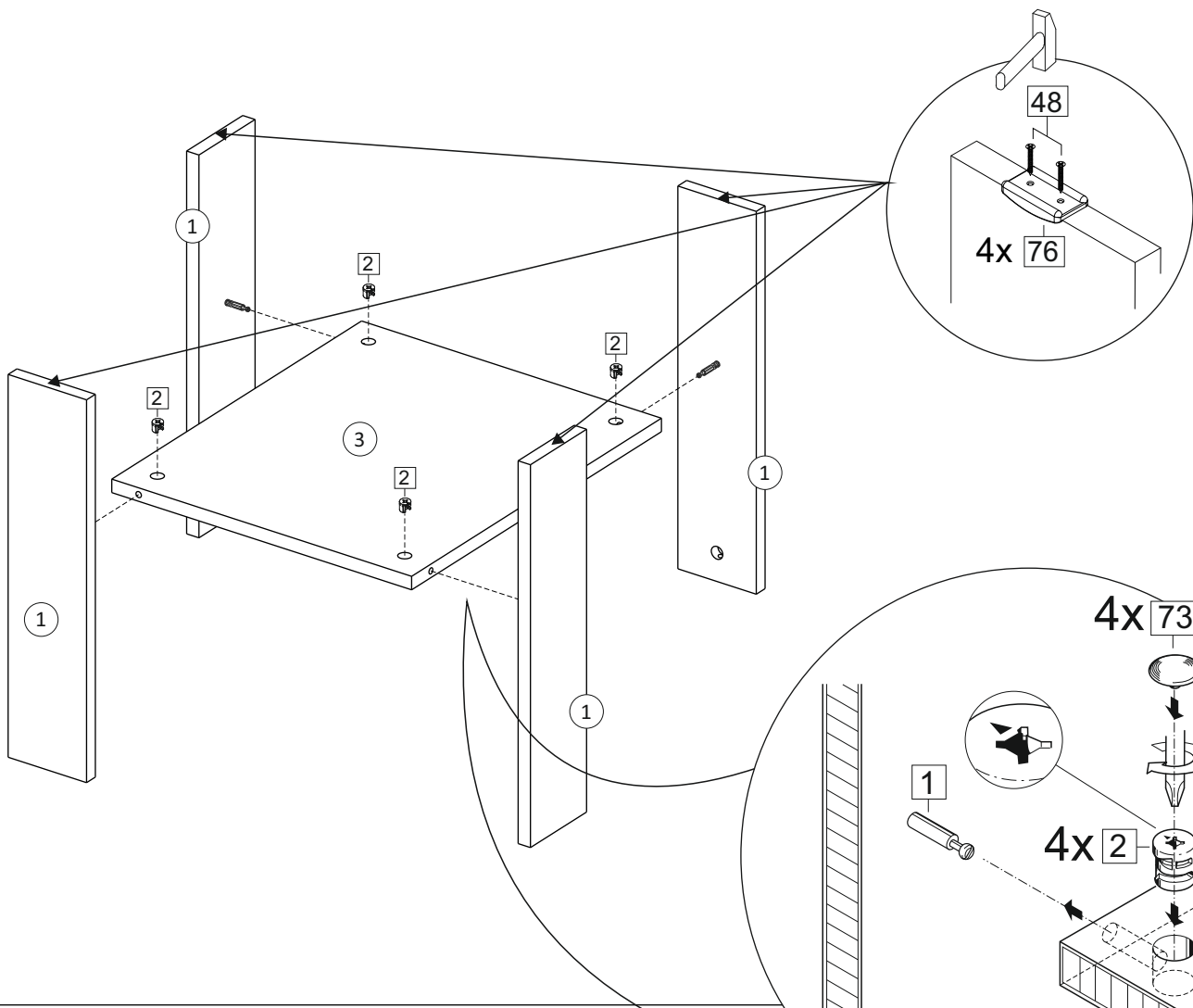



(PL) Instrukcja montażu

(CZ) Návod k montáži

(D) Montageanleitung

(GB) Assembly instruction

(F) Model d'emploi

(HU) Szerelési útmutató

(I) Istruzione di montaggio

(NL) Handleiding voor de montage



(RU) Инструкция по монтажу

(RO) Instrucțiuni de montare

(SK) Návod k montáži

(TR) Montaj talimatı

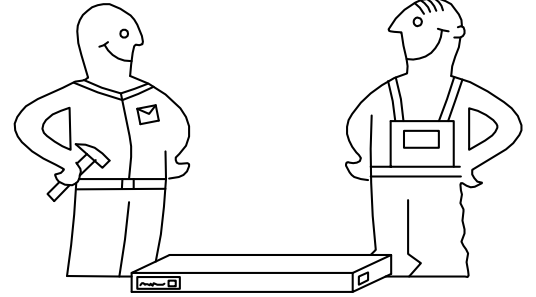
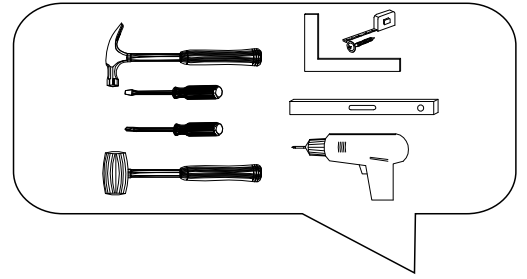

⚠ Uwaga • Upozornění • Achtung • Attention • Caution • Figyelem ⚠ Attenzione • Opgelet • Внимание • Atenție • Upozornenie • Dikkat	
PL	Czyszczenie należy wykonać wyłącznie za pomocą ściereczki lub lekko nawilżonego ręcznika. Nie stosować środków czyszczących do szorowania.
CZ	Čistění je nutné vykonávat výhradně pomocí utěrky nebo lehce navlhčeného ručníku. Nepoužívejte čističí prostředky obsahující abrazivní částice.
D	Bitte nur mit einem Staubtuch oder leicht feuchtem Lappen reinigen. Keine scheuernden Putzmittel verwenden.
GB	Please only clean with a duster or a damp cloth. Do not use any abrasive cleaners.
F	Le nettoyage se fait uniquement à l'aide d'un torchon ou d'une serviette légèrement mouillée.
HU	A tisztítás kizárólag törülköh vagy enyhén nedvesített törölköző segítségével végezhető. Súroló hatású tisztítószerket nem szabad használni.
I	Pulire esclusivamente con un panno o un asciugamano umido.
NL	Reinig alleen met een stofdoek of een lichtjes vochtige doek. Gebruik geen schurende poetsmiddelen.
RU	Очищайте от пыли тряпкой или слегка влажной ветошью. Не допускается применение чистящих средств, не предназначенных для ухода за мебелью.
RO	Curățarea trebuie efectuată numai cu o cârpă sau cu un prosop ușor umezit. Nu utilizați agenți de curățare abrazivi.
SK	Čistení je nutné vykonávať výhradne pomocí utierky alebo ľahko zvlhnutým ručníkom. Nepoužívajte čistiace prostriedky obsahujúce abrazívne častice.
TR	Lütfen sadece bir toz bezilye veya hafif nemli yumuşak bir bezle siliniz. Aşındırıcı temizlik malzemeleri kullanmayınız.

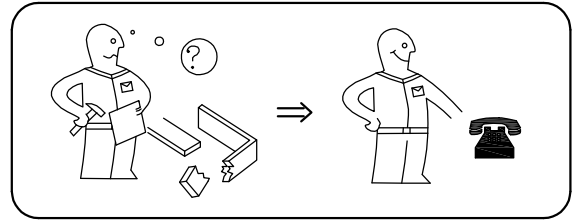
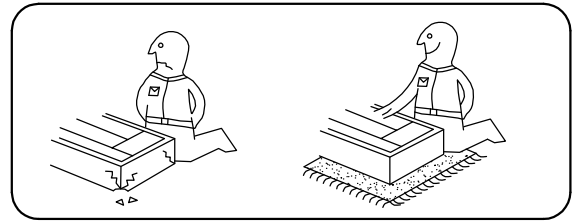

**Karta serwisowa • Servisní list • Service Karte • Service card • Carte de service • Szervizkártya
Scheda di servizio • Service kaart • Сервисная карта • Fisa service • Servisný list • Servis karti**

