

封面

封底



2.0 High-Level Bookshelf Speaker Operating Instructions

CAUTION

- 1. All the safety and operating instructions should be read before the appliance is used.
2. The appliance should not be used near water...

PACKAGE CONTENTS

Table listing package contents: Speaker (1pc), Operation manual (1pc), VCD cable (1pc).

Specifications

Power Output: 35W+35W, Speaker Unit: 3.5" x 4cm x 10W, Frequency Response: 60Hz-20KHz, SN Ratio: >80dB, Power Supply: 220V~50Hz 0.3A, Product Dimension: W125*D125*H223mm

OSTROŻNIĘCIE

- 1. Przed uruchomieniem urządzenia należy zapoznać się ze wszystkim instrukcjami dotyczącymi bezpieczeństwa i obsługi.
2. Należy przestrzegać wszystkich ostrzeżeń i instrukcji.

ZAWARTOŚĆ OPAKOWANIA

Table listing contents: Głośnik (1szt), Podręcznik obsługi (1szt), Kabel VCD (1szt).

Specyfikacja

Moc wyjściowa: 35W+35W, Jednostka głośnikowa: 3,5" x 4 cm, 10W, Częstotliwość pasmowa: 60Hz-20kHz, Stosunek sygnału do szumu: >80dB, Zasilanie: 220V~50Hz 0,3A, Wymiary produktu: W125xD125xH223mm

VORSICHT:

- 1. Lesen Sie alle Sicherheits- und Bedienungsanleitungen, bevor Sie das Gerät in Betrieb nehmen.
2. Alle Bedienungsanleitungen müssen beachtet werden.

INHALT DER VERPACKUNG

Table listing contents: Lautsprecher (1 Stk), Bedienungsanleitung (1 Stk), VCD-Kabel (1 Stk).

Technische Daten

Leistungsausgang: 35W+35W, Lautsprechertrieb: 3,5" x 4 cm, 10 W, Frequenzbereich: 60 Hz - 20 kHz, SN-Verhältnis: >80 dB, Netzspannung: 220 V ~ 50 Hz, 0,3 A, Produktmaße: B125xT125xH223 mm

ATTENTION:

- 1. Il est nécessaire de lire toutes les instructions d'utilisation et consignes de sécurité avant d'utiliser cet appareil.
2. Toutes les instructions d'utilisation et autres doivent être suivies.

CONTENU DE L'EMBALLAGE

Table listing contents: Émetteur (1), Câble pour VCD (1).

Caractéristiques

Puissance de sortie: 35 W + 35 W, Transducteur: 3,5 pouces, 4 cm, 10 W, Bande passante: de 60 à 20 000 Hz, Rapport signal/bruit: >80 dB, Alimentation: 220 V ~ 50 Hz, 0,3 A, Dimensions du produit: L 125 x P 125 x H 223 mm

ATENCIÓN:

- 1. Lea de utilizar cualquier aparato antes de leer todas las instrucciones de seguridad y de operación.
2. Lea todas las instrucciones de seguridad y de operación.

CONTENIDO DEL PAQUETE

Table listing contents: Altavoz (1 unidad), Manual de usuario (1 pc), Cable VCD (1 pc).

Características

Potencia de salida: 35 W + 35 W, Altavoz: 3,5" de diámetro, 4 cm, 10 W, Frecuencia de respuesta: 60 Hz - 20 kHz, Relación Señal/Ruido: >80 dB, Fuente de alimentación: 220V-50Hz 0,3A, Dimensiones del producto: L 125 x P 125 x H 223 mm

PRECAUTION:

- 1. Read all the instructions on safety and operation before using the equipment.
2. Read all the instructions on safety and operation.

CONTÉUDO DA EMBALAGEM

Table listing contents: Alto-falante (1 unidade), Manual de utilização (1 pc), Cabo VCD (1 pc).

Especificações

Potência de saída: 35 W + 35 W, Alto-falante: 3,5" de diâmetro, 4 cm, 10 W, Faixa de frequência: 60 Hz - 20 kHz, Relação Sinal/Ruído: >80 dB, Fonte de energia: 220 V - 50 Hz, 0,3 A, Dimensões do produto: Larg 125 x Prof 125 x Alt 223 mm

PRECAUTIONS:

- 1. Read all the instructions on safety and security before using the equipment.
2. Read all the instructions on safety and security.

CONTENIDOS DEL PAQUETE

Table listing contents: Altoparlante (1 pieza), Manual de operación (1 pieza), Cable VCD (1 pieza).

Especificaciones

Potencia de salida: 35 W + 35 W, Altavoz: 3,5" de diámetro, 4 cm, 10 W, Frecuencia de respuesta: 60 Hz - 20 kHz, Relación Señal/Ruido: >80 dB, Fuente de alimentación: 220V-50Hz 0,3A, Dimensiones del producto: L 125 x P 125 x H 223 mm

ATTENZIONE:

- 1. Prima di utilizzare l'apparecchio leggere tutte le istruzioni di sicurezza e di funzionamento.
2. Leggere attentamente le istruzioni per l'uso e per l'utente.

CONTENUTO DELLA CONFEZIONE

Table listing contents: Altoparlante (1 pezzo), Manuale operativo (1 pezzo), Cabo VCD (1 pezzo).

Specifiche tecniche

Potenza in uscita: 35 W + 35 W, Unità altoparlante: 3,5" x 4 cm, 10 W, Frecuencia de respuesta: 60 Hz - 20 kHz, Relación Señal/Ruido: >80 dB, Alimentación: 220V-50Hz 0,3A, Dimensiones del producto: larghezza 125 x profundidad 125 x altura 223 mm

OSTORNOŽENJE

- 1. Pred korišćenje ovog uređaja pažljivo pročitajte sve uputstvo po bezbednosti i uputstvo za korišćenje ovog uređaja.
2. Sve uputstvo po bezbednosti i uputstvo za korišćenje ovog uređaja morate pažljivo pročitati.

Содержимое упаковки

Table listing contents: Колонка (1 шт), Руководство по эксплуатации (1 шт), Кабель VCD (1 шт).

Технические характеристики

Мощность выходная: 35 Вт + 35 Вт, Диаметр динамика: 89 мм, Частотный диапазон: 60 Гц - 20 000 Гц, Соотношение сигнал/шум: >80 дБ, Питание: 220 В ~ 50 Гц, 0,3 А, Размеры: 125x125x223 мм

注意事項

- 1. 必ず電源を使用する前に安全上の注意事項をよく読んでください。
2. 必ず電源を使用する前に安全上の注意事項をよく読んでください。

パッケージ内容

Table listing contents: スピーカー (1), ユーザーマニュアル (1), VCDケーブル (1).

仕様

出力: 35W+35W, スピーカーユニット: 3.5" x 4cm, 10W, 周波数特性: 60Hz-20kHz, SN比: >80dB, 電源: 220V-50Hz 0.3A, 製品寸法: W125xD125xH223mm

BUTTON CONTROLS

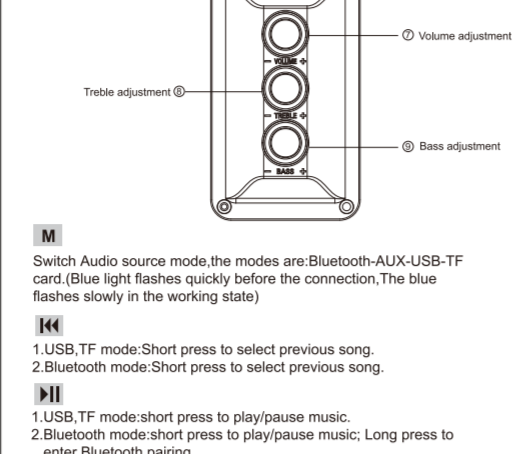

PRZYKISKI STERUJĄCE

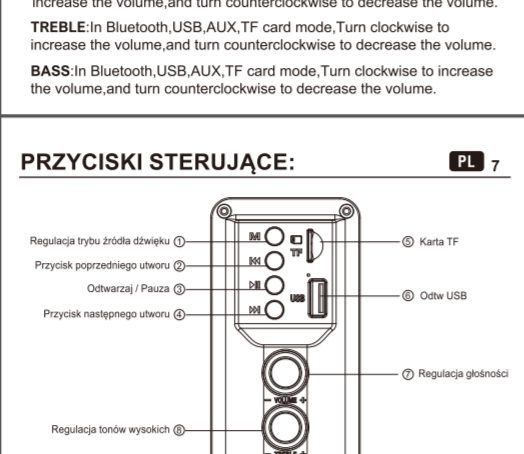

TASTENSTEUERUNG:

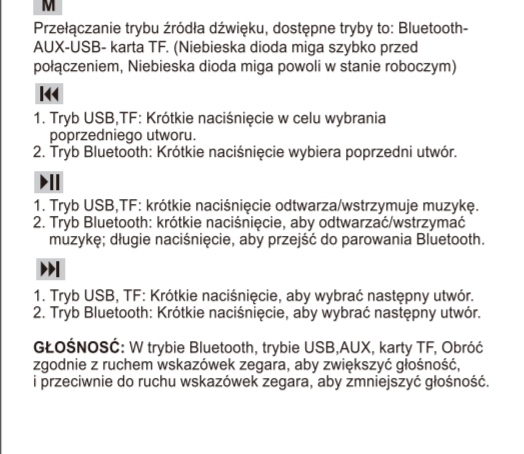

BUTTONS DE COMMANDE

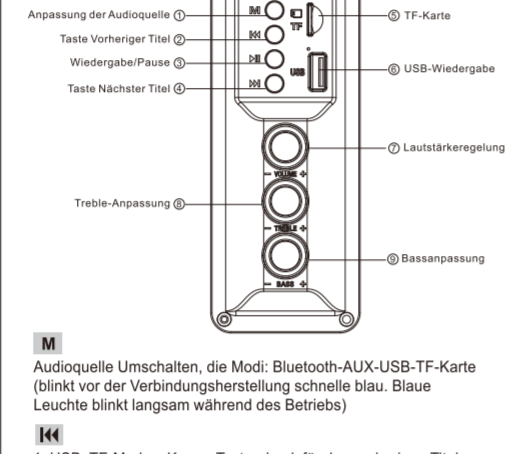

БУТОНА ОПЕРАТОРА

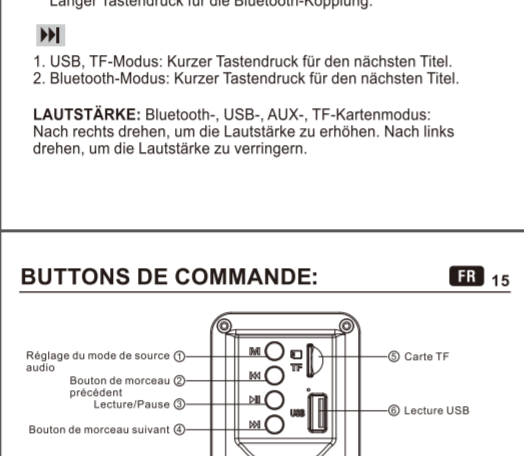

CONTROLES POR BOTONES

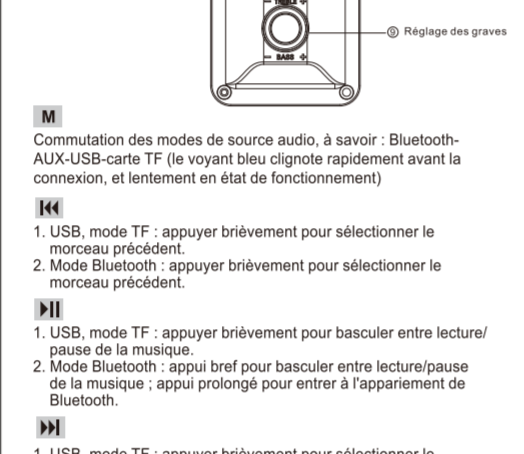

COMMANDI A PULSANTE

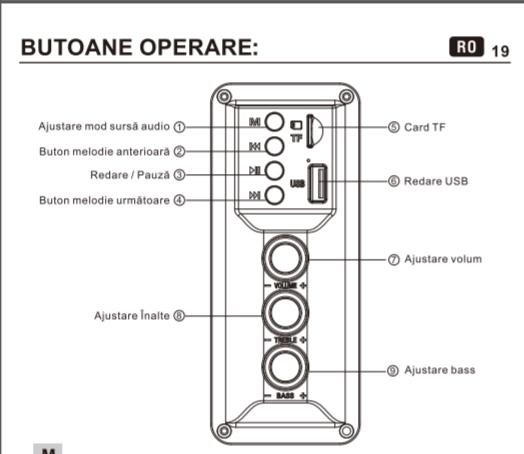

КНОПКИ УПРАВЛЕНИЯ

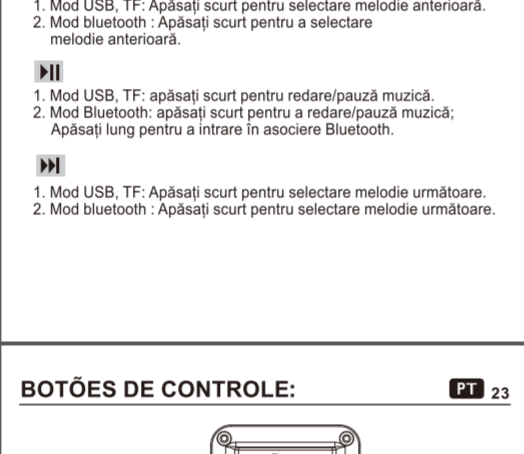

ボタンの操作

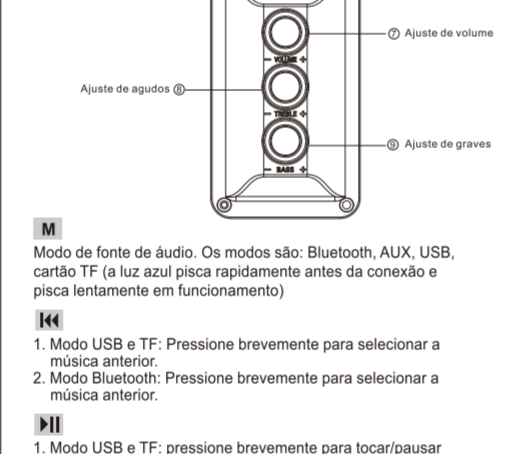

CONTROL PANEL FUNCTIONS:

- Power switch, Power cable, Left channel input, Right channel input, Left channel output, Right channel output.

OPERATE FUNCTIONS:

- Bluetooth mode, Turn on the speaker and default Bluetooth, Turn on your Bluetooth function on your device, Enter 00007F as the PIN code to connect with GSE13.

OPERATE FUNCTIONS:

- Bluetooth mode, Turn on the speaker and default Bluetooth, Turn on your Bluetooth function on your device, Enter 00007F as the PIN code to connect with GSE13.

OPERATE FUNCTIONS:

- Bluetooth mode, Turn on the speaker and default Bluetooth, Turn on your Bluetooth function on your device, Enter 00007F as the PIN code to connect with GSE13.

OPERATE FUNCTIONS:

- Bluetooth mode, Turn on the speaker and default Bluetooth, Turn on your Bluetooth function on your device, Enter 00007F as the PIN code to connect with GSE13.

OPERATE FUNCTIONS:

- Bluetooth mode, Turn on the speaker and default Bluetooth, Turn on your Bluetooth function on your device, Enter 00007F as the PIN code to connect with GSE13.

OPERATE FUNCTIONS:

- Bluetooth mode, Turn on the speaker and default Bluetooth, Turn on your Bluetooth function on your device, Enter 00007F as the PIN code to connect with GSE13.

OPERATE FUNCTIONS:

- Bluetooth mode, Turn on the speaker and default Bluetooth, Turn on your Bluetooth function on your device, Enter 00007F as the PIN code to connect with GSE13.

OPERATE FUNCTIONS:

- Bluetooth mode, Turn on the speaker and default Bluetooth, Turn on your Bluetooth function on your device, Enter 00007F as the PIN code to connect with GSE13.

OPERATE FUNCTIONS:

- Bluetooth mode, Turn on the speaker and default Bluetooth, Turn on your Bluetooth function on your device, Enter 00007F as the PIN code to connect with GSE13.

OPERATE FUNCTIONS:

- Bluetooth mode, Turn on the speaker and default Bluetooth, Turn on your Bluetooth function on your device, Enter 00007F as the PIN code to connect with GSE13.

OPERATE FUNCTIONS:

- Bluetooth mode, Turn on the speaker and default Bluetooth, Turn on your Bluetooth function on your device, Enter 00007F as the PIN code to connect with GSE13.

OPERATE FUNCTIONS:

- Bluetooth mode, Turn on the speaker and default Bluetooth, Turn on your Bluetooth function on your device, Enter 00007F as the PIN code to connect with GSE13.

OPERATE FUNCTIONS:

- Bluetooth mode, Turn on the speaker and default Bluetooth, Turn on your Bluetooth function on your device, Enter 00007F as the PIN code to connect with GSE13.

OPERATE FUNCTIONS:

- Bluetooth mode, Turn on the speaker and default Bluetooth, Turn on your Bluetooth function on your device, Enter 00007F as the PIN code to connect with GSE13.

OPERATE FUNCTIONS:

- Bluetooth mode, Turn on the speaker and default Bluetooth, Turn on your Bluetooth function on your device, Enter 00007F as the PIN code to connect with GSE13.

OPERATE FUNCTIONS:

- Bluetooth mode, Turn on the speaker and default Bluetooth, Turn on your Bluetooth function on your device, Enter 00007F as the PIN code to connect with GSE13.

CONNECTION DIAGRAM:

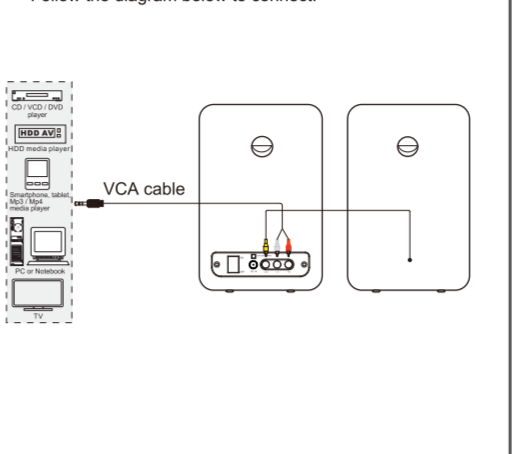

CONNECTION DIAGRAM:



CONNECTION DIAGRAM:

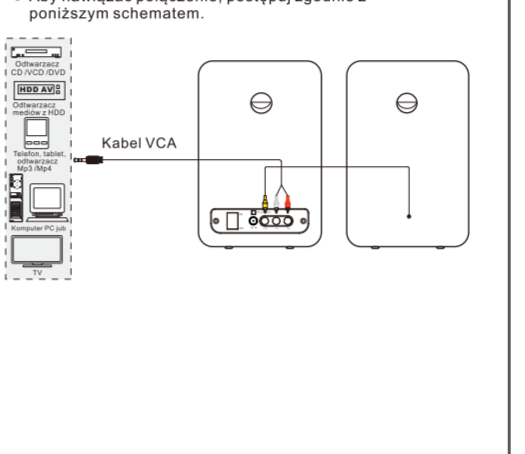

CONNECTION DIAGRAM:

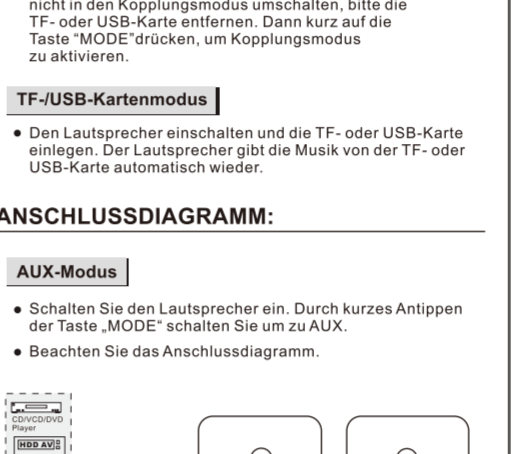

CONNECTION DIAGRAM:

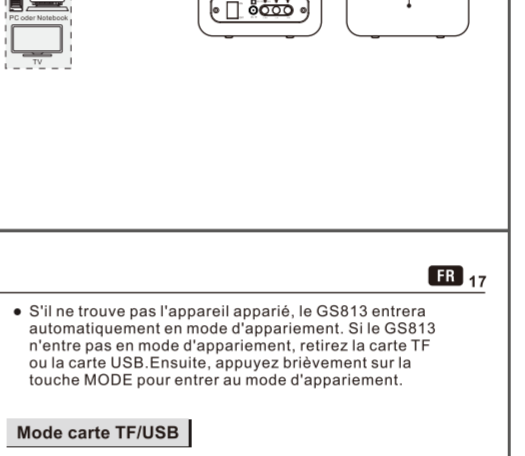

CONNECTION DIAGRAM:

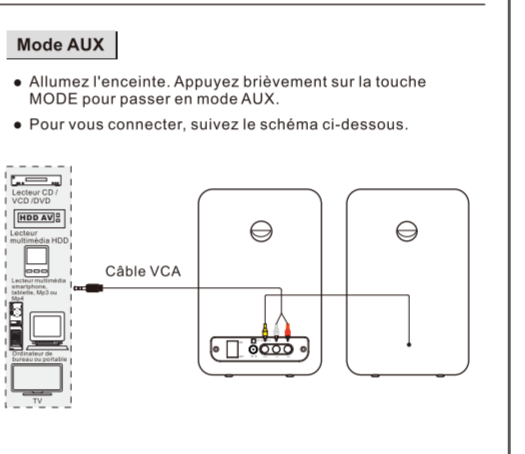

CONNECTION DIAGRAM:

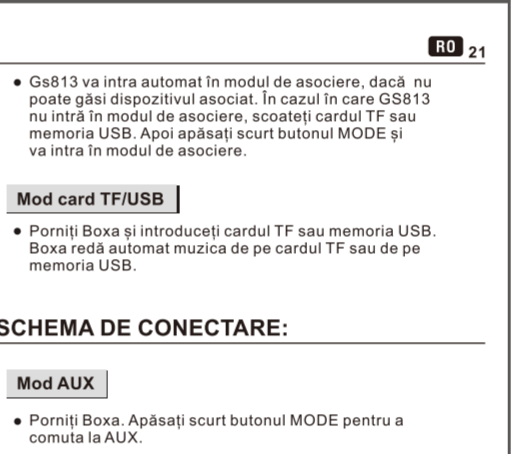

CONNECTION DIAGRAM:

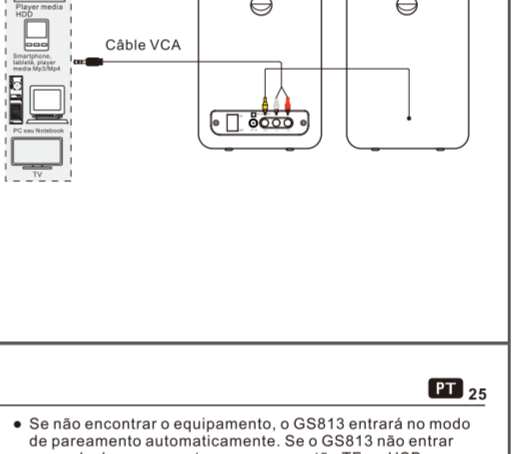

CONNECTION DIAGRAM:

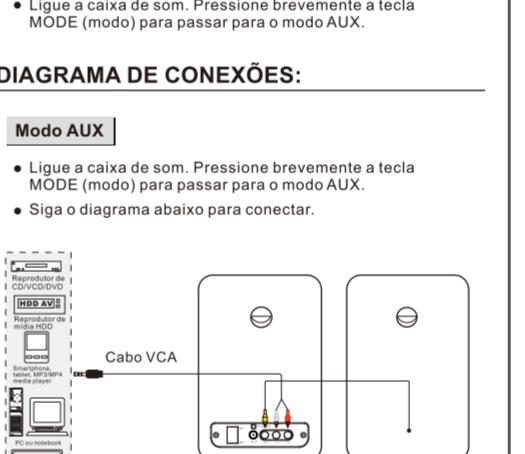

CONNECTION DIAGRAM:

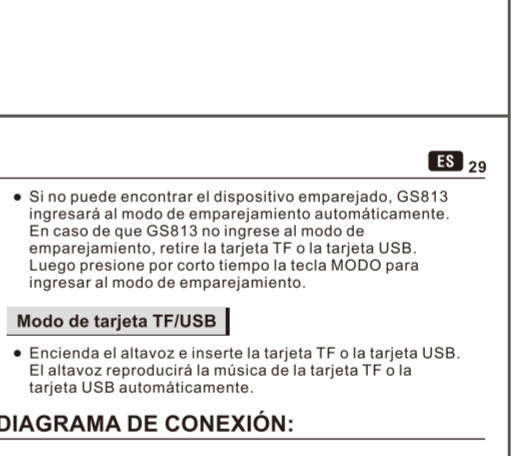

CONNECTION DIAGRAM:

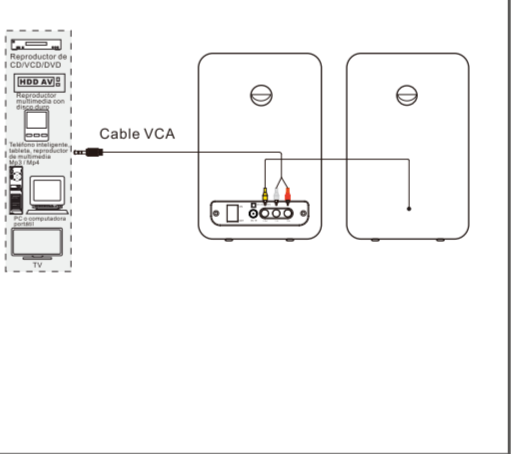

CONNECTION DIAGRAM:

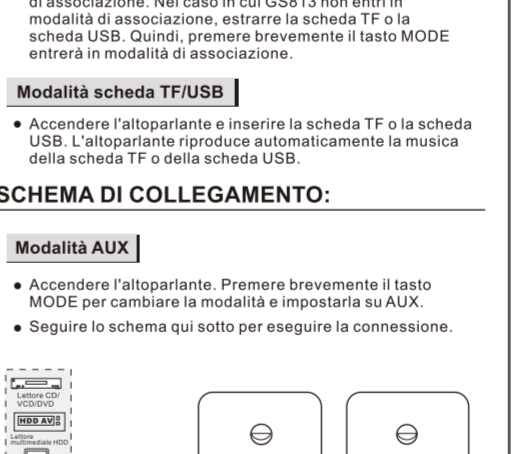

CONNECTION DIAGRAM:

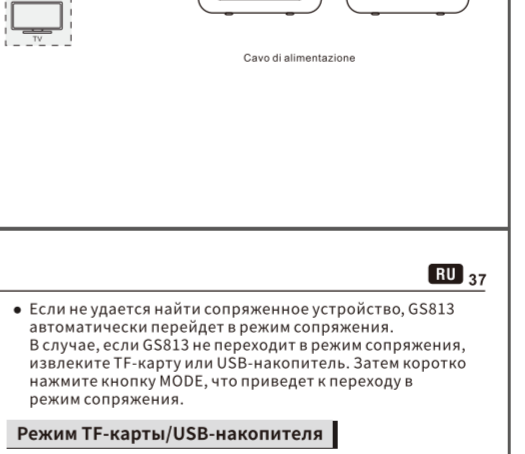

CONNECTION DIAGRAM:

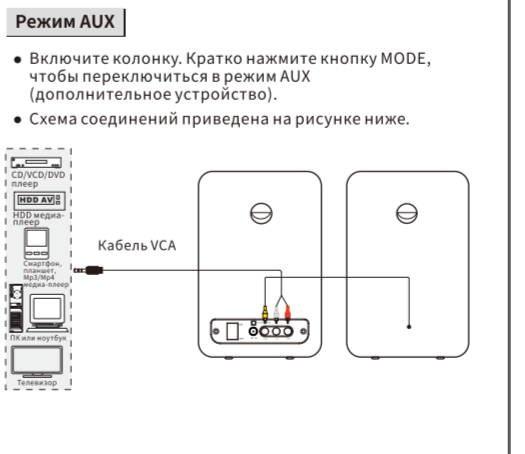

CONNECTION DIAGRAM:

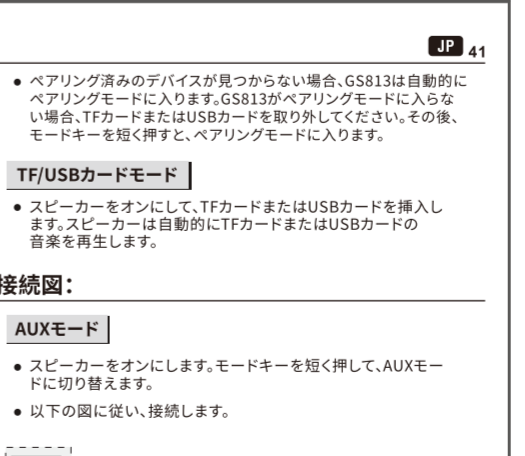

CONNECTION DIAGRAM:

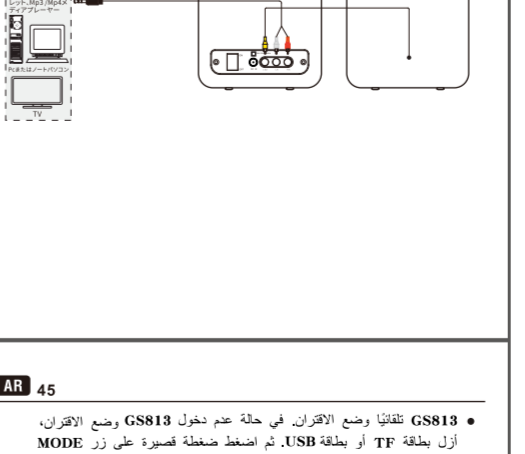

CONNECTION DIAGRAM:

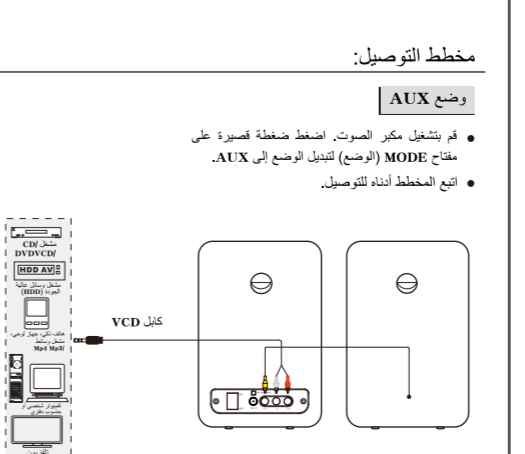

FCC STATEMENT:

Changes or modifications not expressly approved by the party responsible for compliance could void the user's authority to operate the equipment.

FCC STATEMENT:

Changes or modifications not expressly approved by the party responsible for compliance could void the user's authority to operate the equipment.

FCC STATEMENT:

Changes or modifications not expressly approved by the party responsible for compliance could void the user's authority to operate the equipment.

FCC STATEMENT:

Changes or modifications not expressly approved by the party responsible for compliance could void the user's authority to operate the equipment.

FCC STATEMENT:

Changes or modifications not expressly approved by the party responsible for compliance could void the user's authority to operate the equipment.

FCC STATEMENT:

Changes or modifications not expressly approved by the party responsible for compliance could void the user's authority to operate the equipment.

FCC STATEMENT:

Changes or modifications not expressly approved by the party responsible for compliance could void the user's authority to operate the equipment.

FCC STATEMENT:

Changes or modifications not expressly approved by the party responsible for compliance could void the user's authority to operate the equipment.

FCC STATEMENT:

Changes or modifications not expressly approved by the party responsible for compliance could void the user's authority to operate the equipment.

FCC STATEMENT:

Changes or modifications not expressly approved by the party responsible for compliance could void the user's authority to operate the equipment.

FCC STATEMENT:

Changes or modifications not expressly approved by the party responsible for compliance could void the user's authority to operate the equipment.

FCC STATEMENT:

Changes or modifications not expressly approved by the party responsible for compliance could void the user's authority to operate the equipment.

FCC STATEMENT:

Changes or modifications not expressly approved by the party responsible for compliance could void the user's authority to operate the equipment.

FCC STATEMENT:

Changes or modifications not expressly approved by the party responsible for compliance could void the user's authority to operate the equipment.

FCC STATEMENT:

Changes or modifications not expressly approved by the party responsible for compliance could void the user's authority to operate the equipment.

FCC STATEMENT:

Changes or modifications not expressly approved by the party responsible for compliance could void the user's authority to operate the equipment.

FCC STATEMENT:

Changes or modifications not expressly approved by the party responsible for compliance could void the user's authority to operate the equipment.