

N1800

1800x2150x600

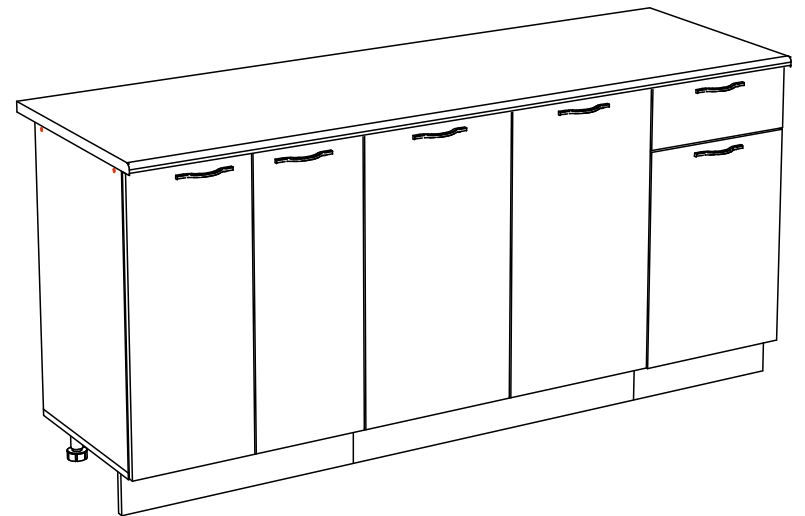

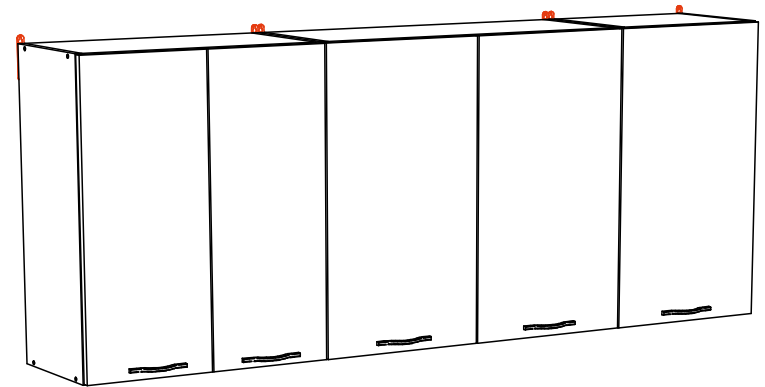
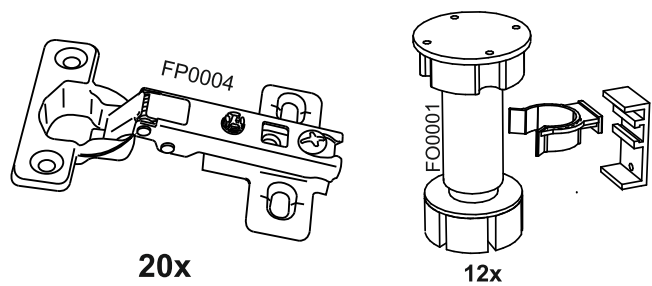
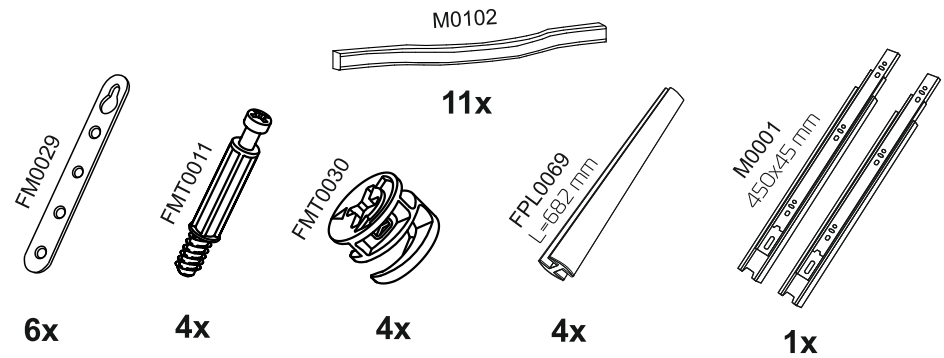
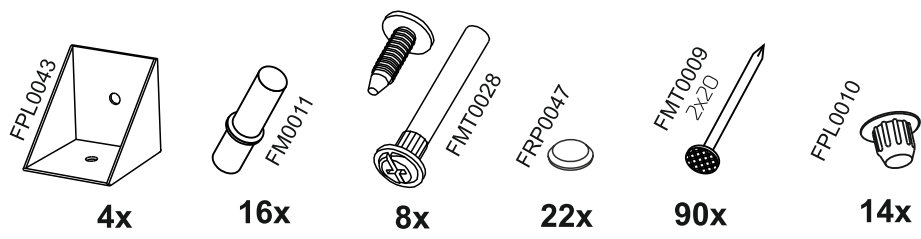
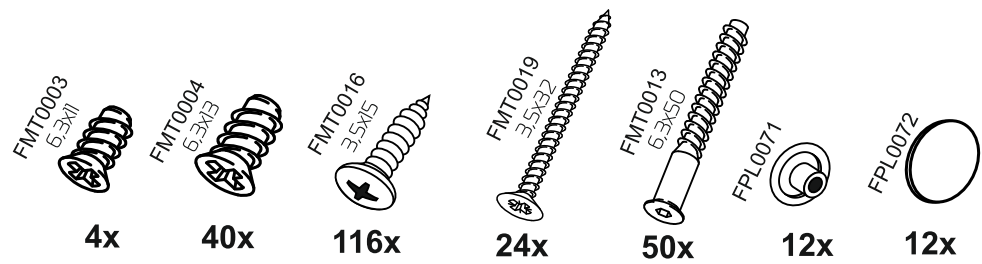

FMT0014 see in furniture under the sink
 FMT0014 ищите в каркасе под мойку



1x

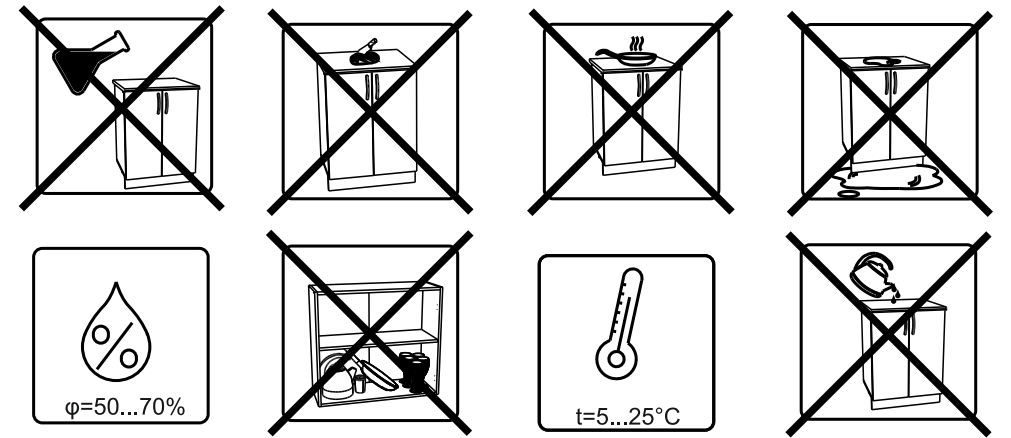
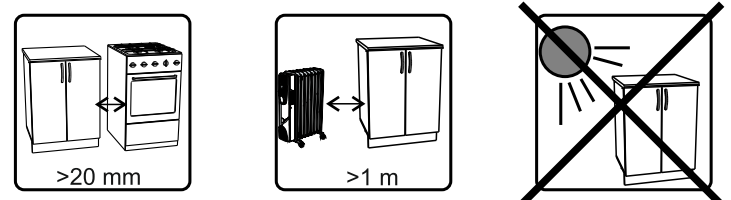
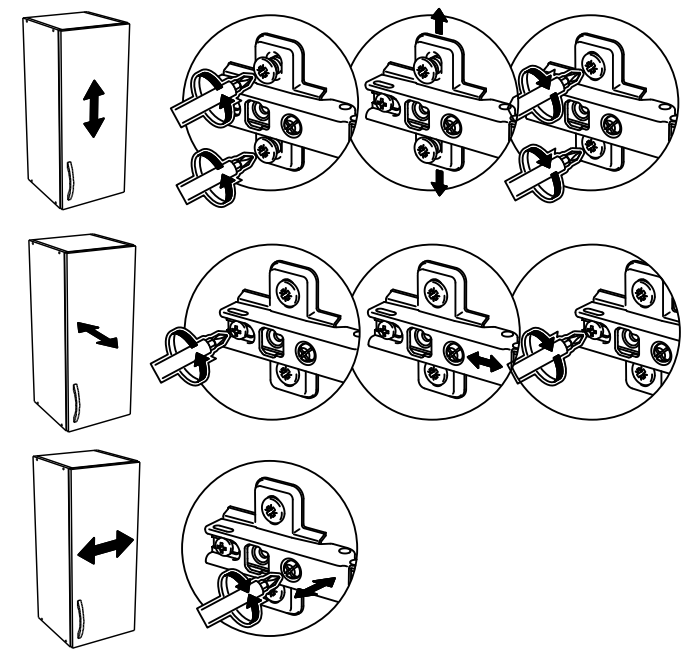
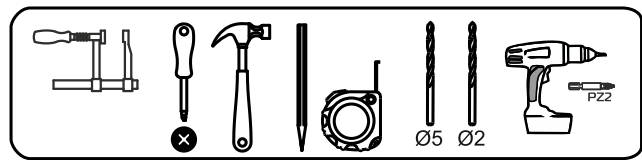

40

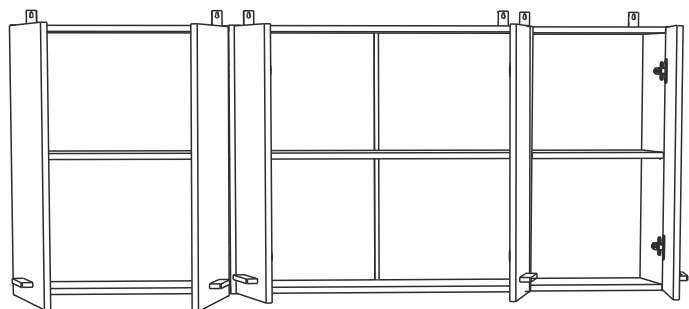

22x

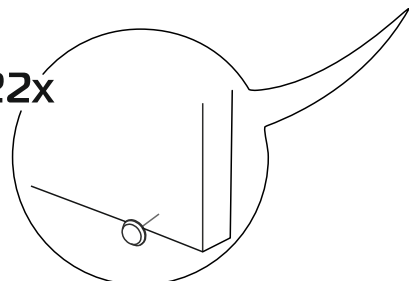

FRP0047

FPL0071

12x

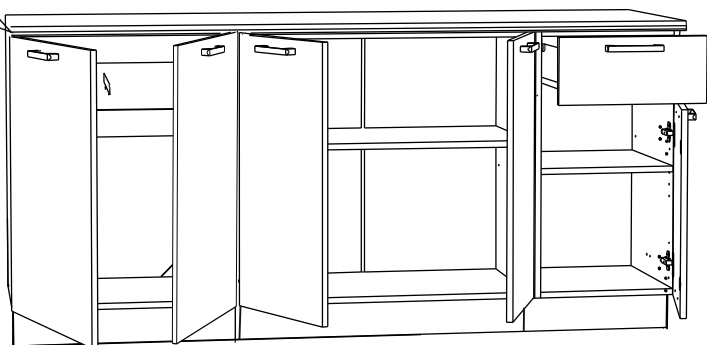
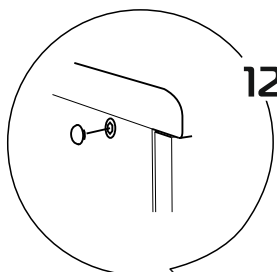

V400
V600
V800

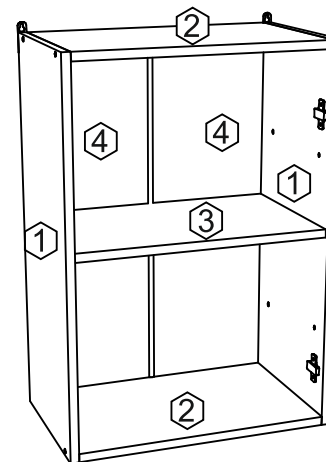

No	code	a*b	module		
			V400	V600	V800
1	V300.01	716*298	2	2	2
2	V400.01	368*298	2		
	V600.01	568*298		2	
	V800.01	768*298			2
3	V400.02	368*290	1		
	V600.02	568*290		1	
	V800.02	768*290			1
4	V300.04	715*295		2	
	V400.03	715*197	2		
	V800.03	715*395			2
5	V300.01	716*296		2	
	V400.01	716*396	1		2

1

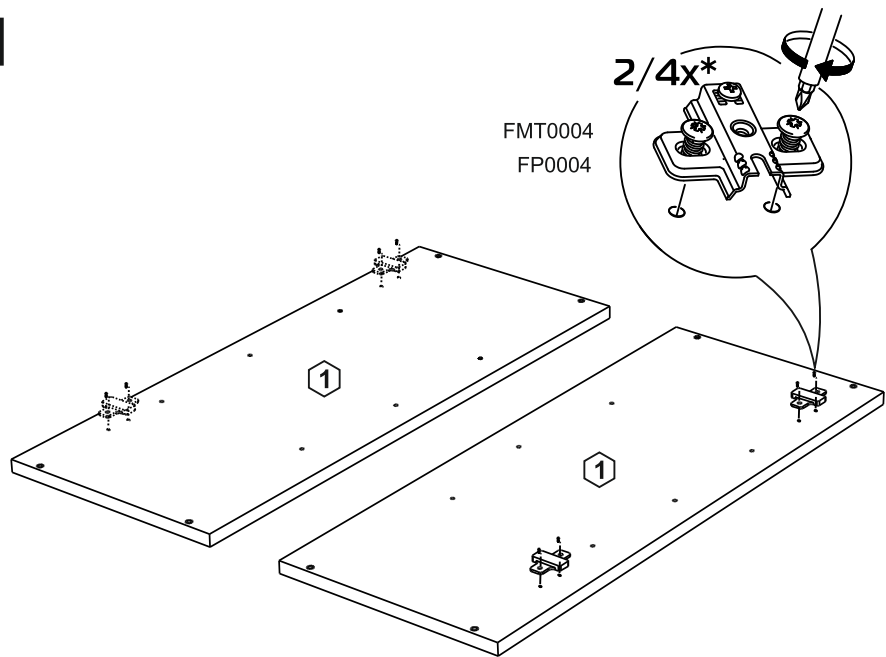

2

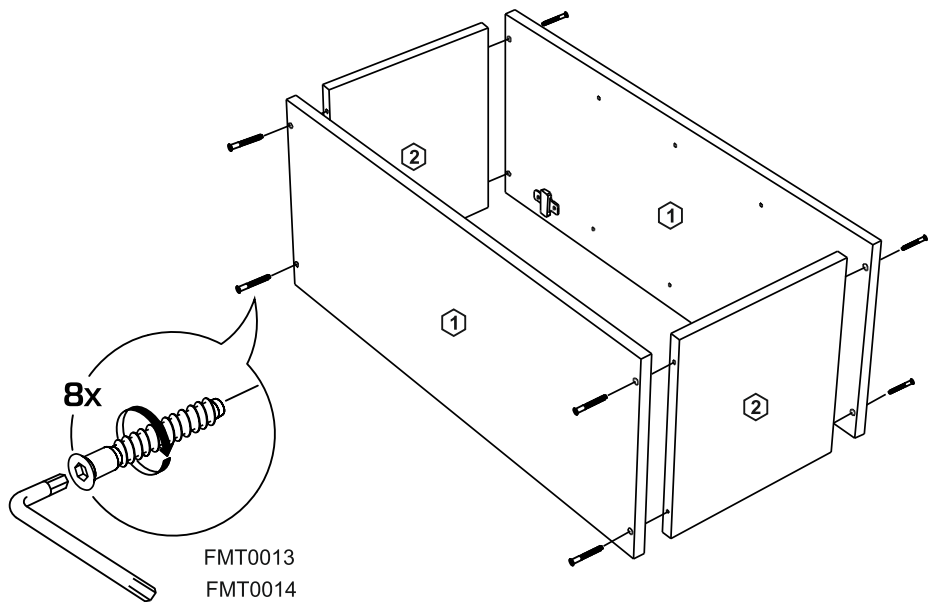

39

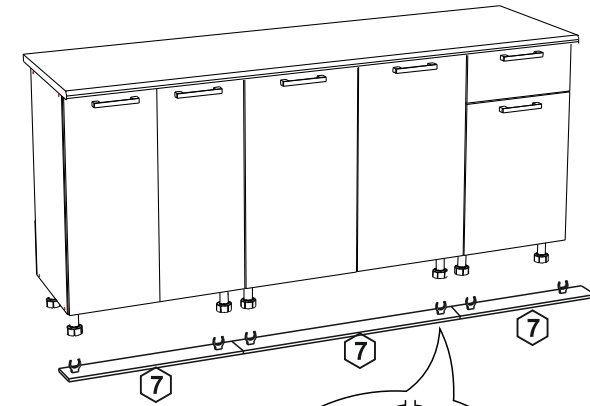
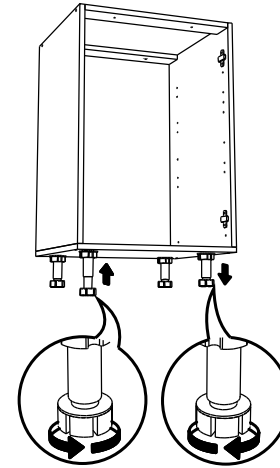

38

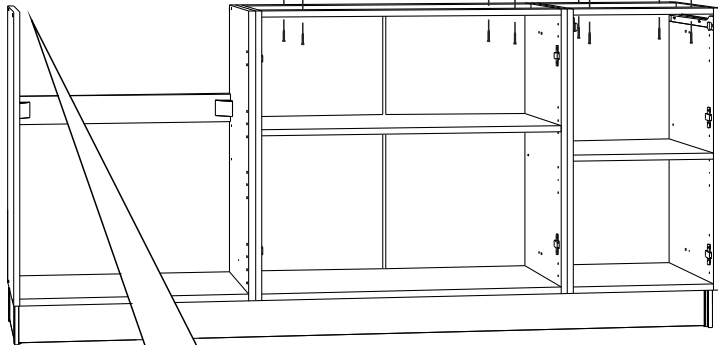
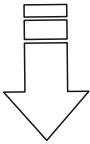
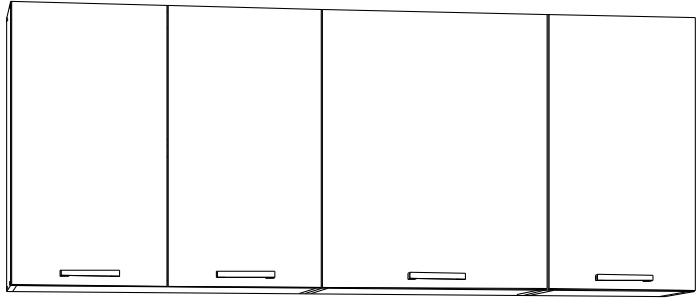

FMT0019

8x

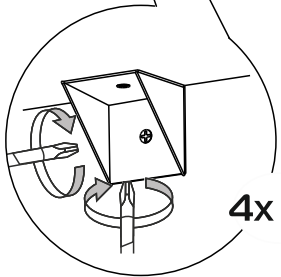
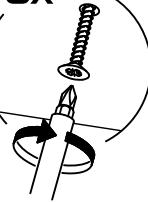

FPL0043
FMT0016

4x

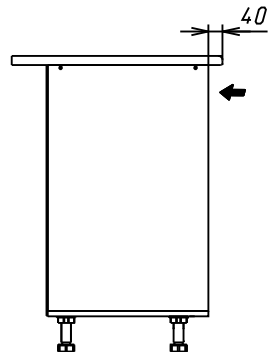

3

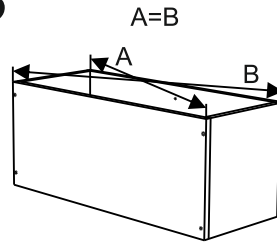

A=B

FMT0009

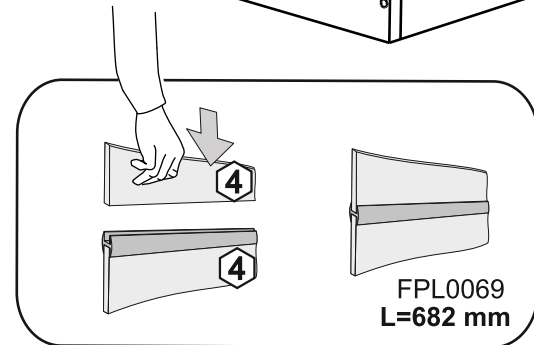
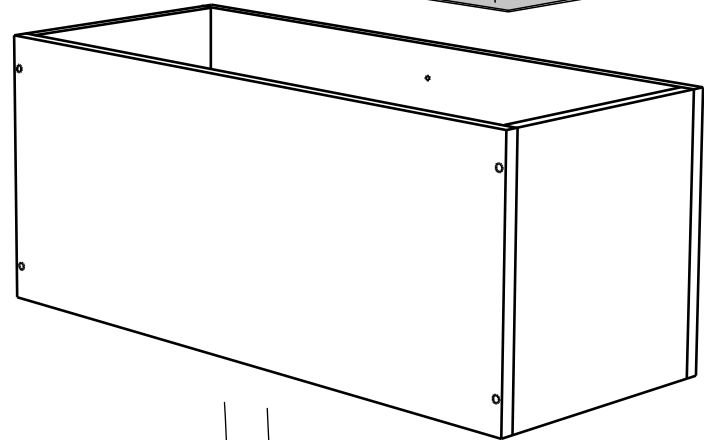
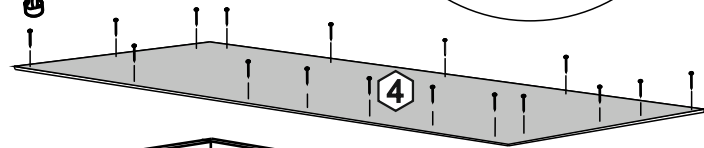
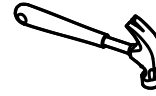
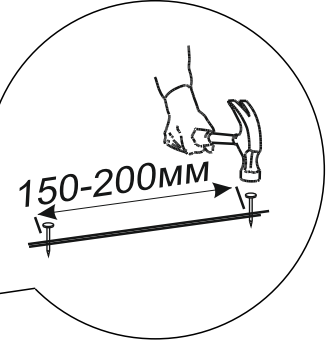

FPL0069
L=682 mm

4

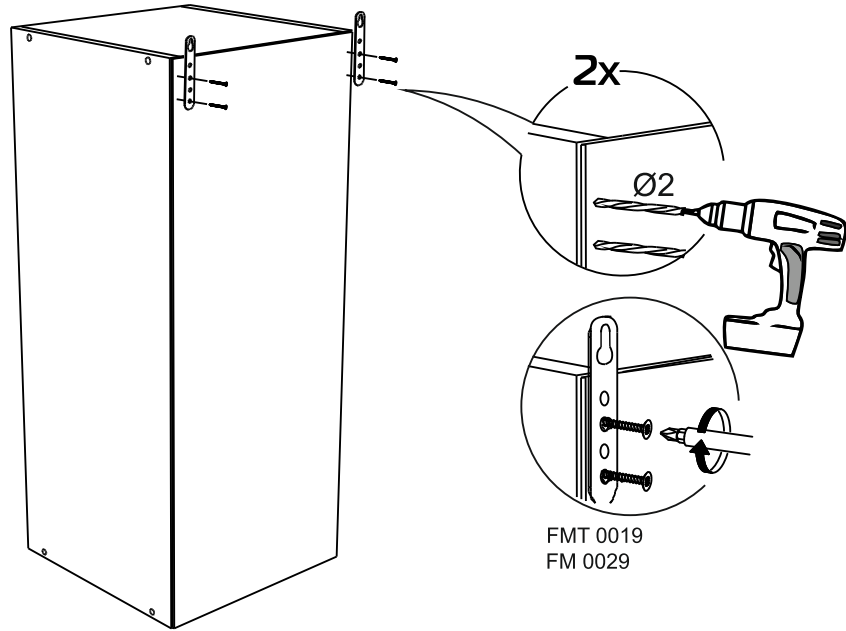

5

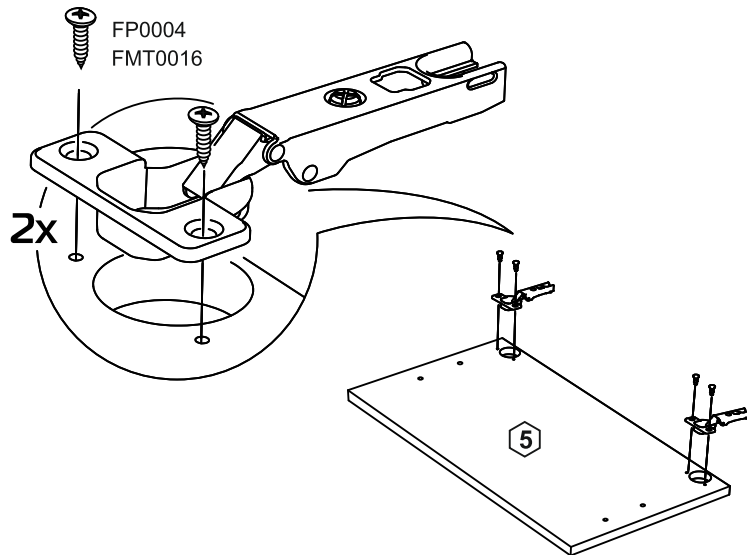

37

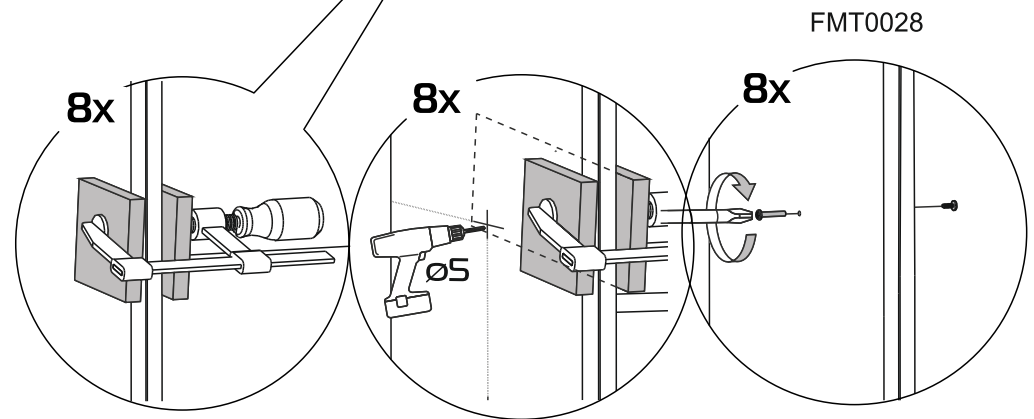
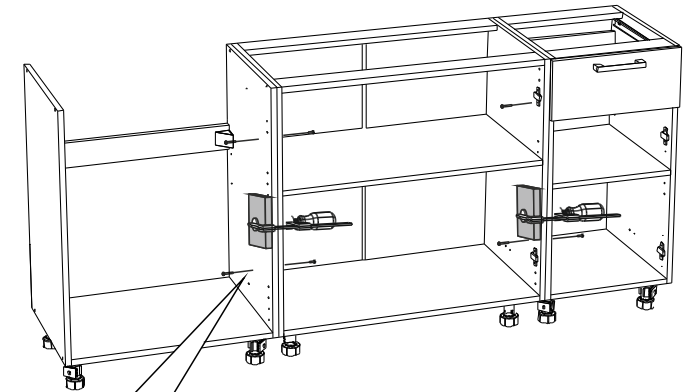
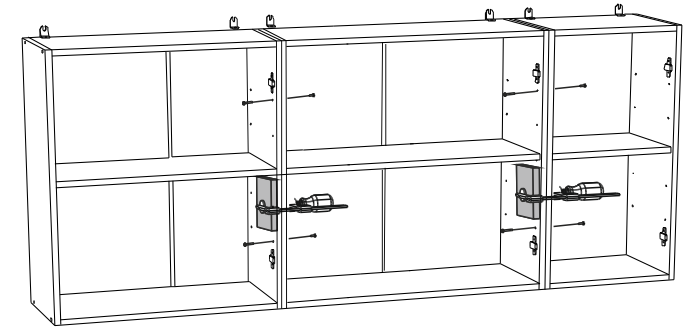

35

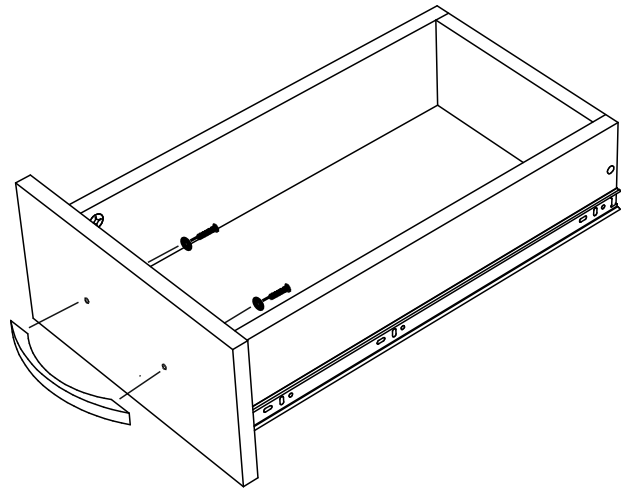

6

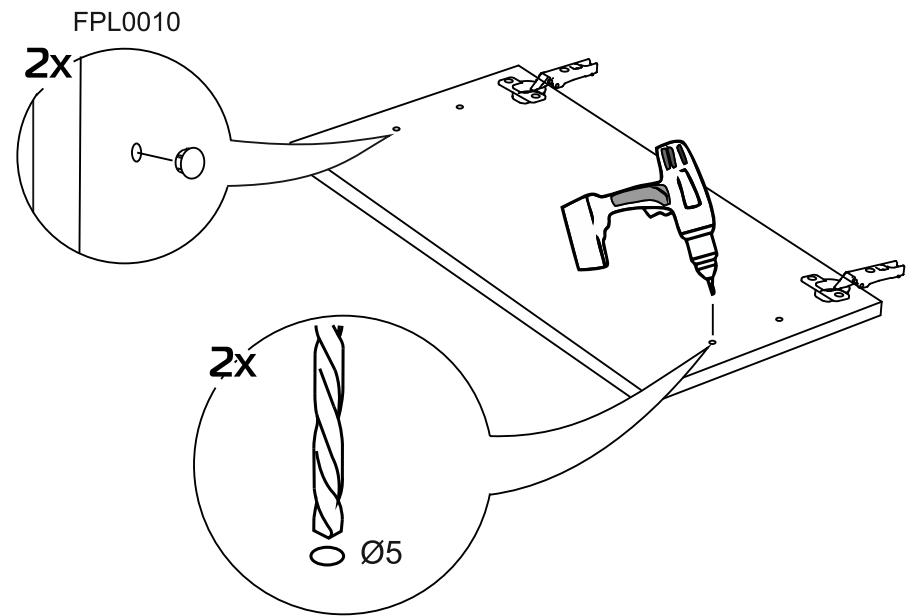

36

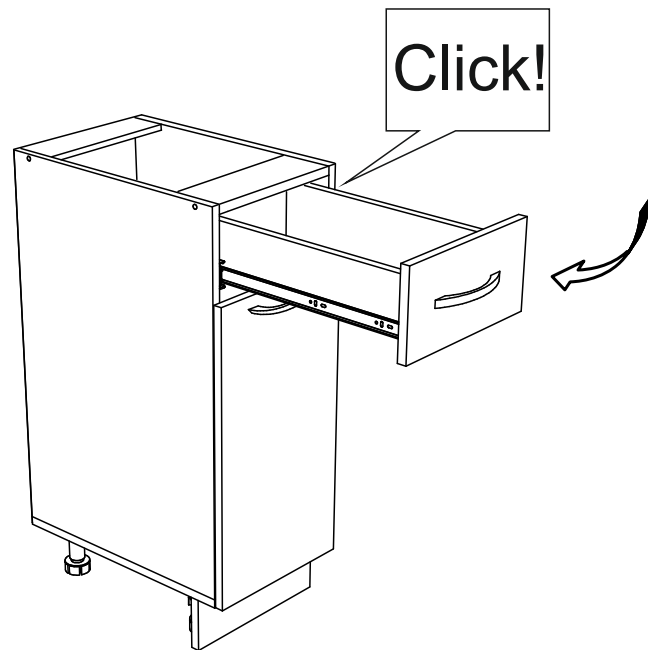

7

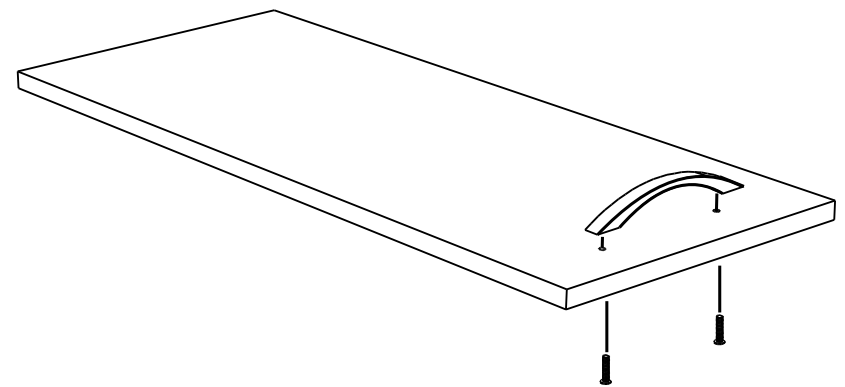

8

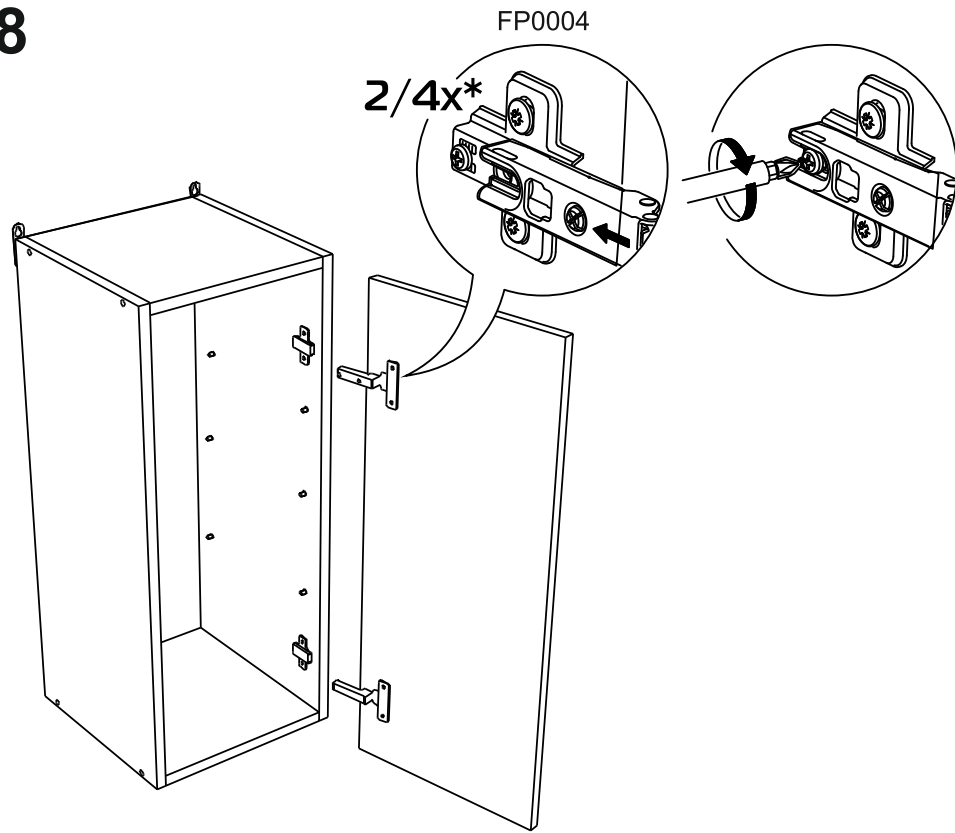

33

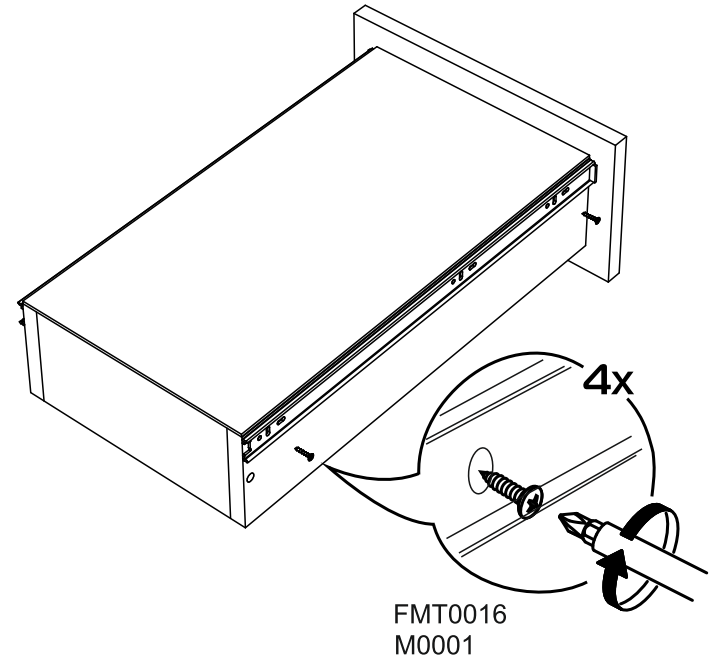

9

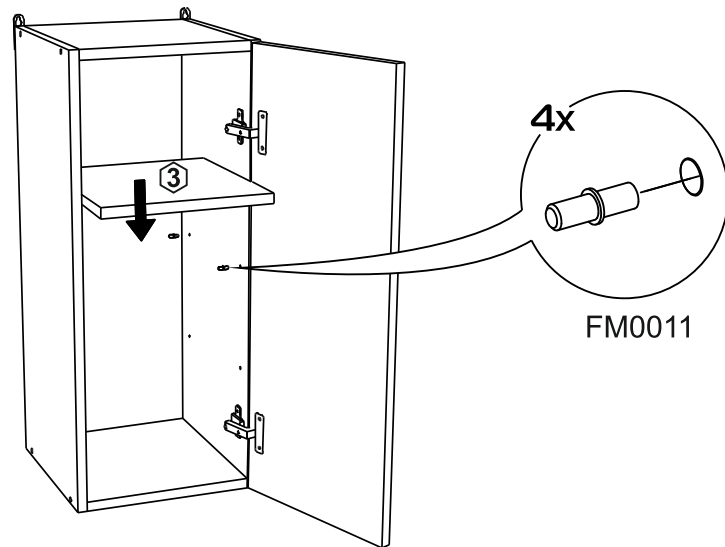

34

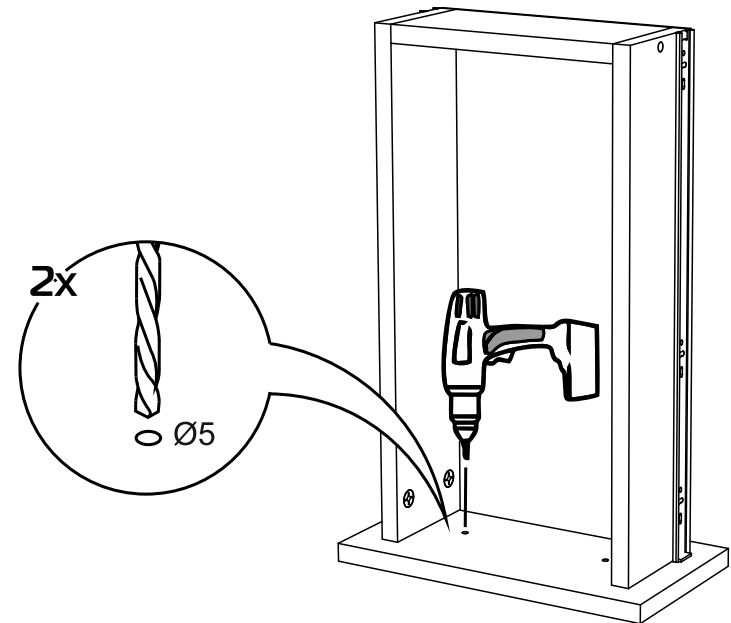

31

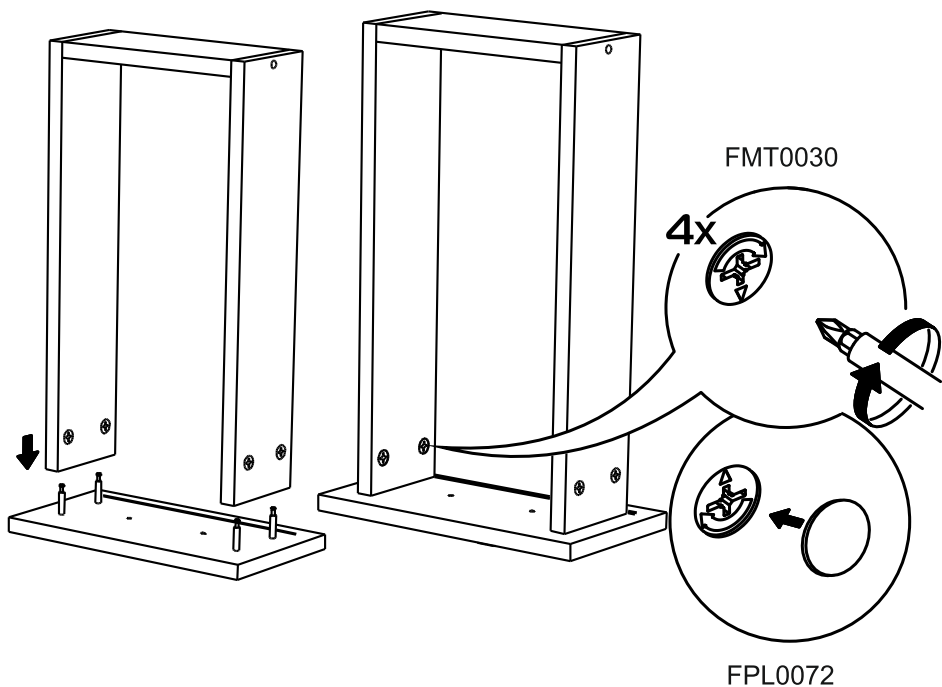

32

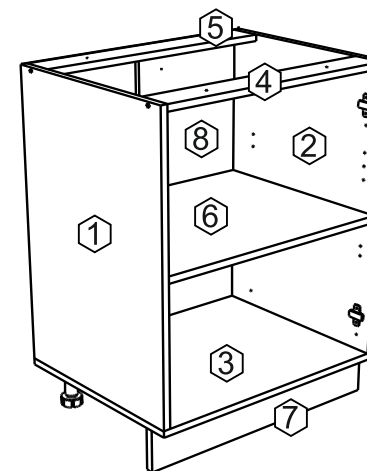
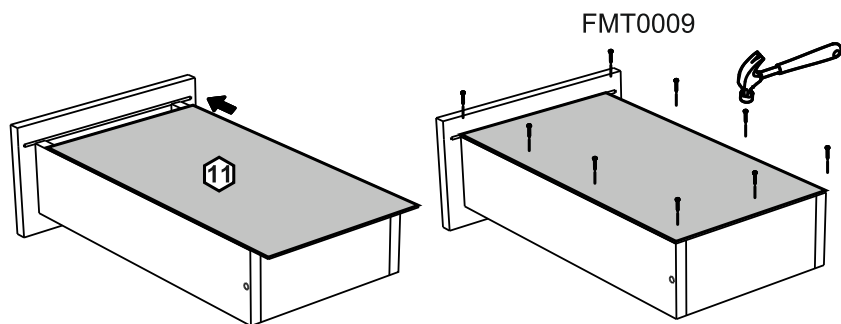

No	code	a*b	module	
			N600	N800
1	N300.01	700*458	1	1
2	N300.02	700*458	1	1
3	N600.01	600*458	1	
	N800.01	800*458		1
4	N600.02	568*74	1	
	N800.02	768*74		1
5	N600.03	568*74	1	
	N800.03	768*74		1
6	N600.04	568*458	1	
	N800.04	768*458		1
7	N600.05	600*100	1	
	N800.05	800*100		1
8	V300.04	715*295	2	
	V800.03	715*395		2
9	V300.01	712*296	2	
	V400.01	712*396		2

10

FMT0004
FP0004

2/4x*

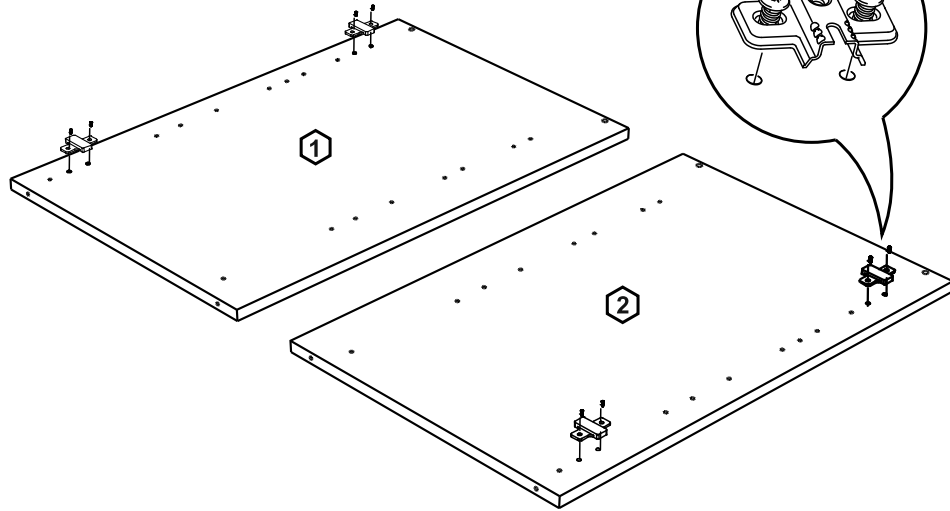

28

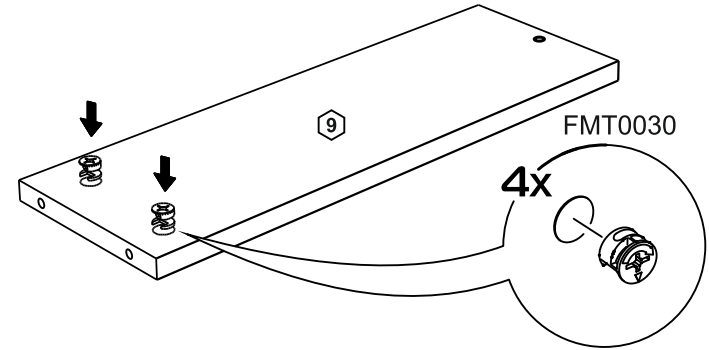

29

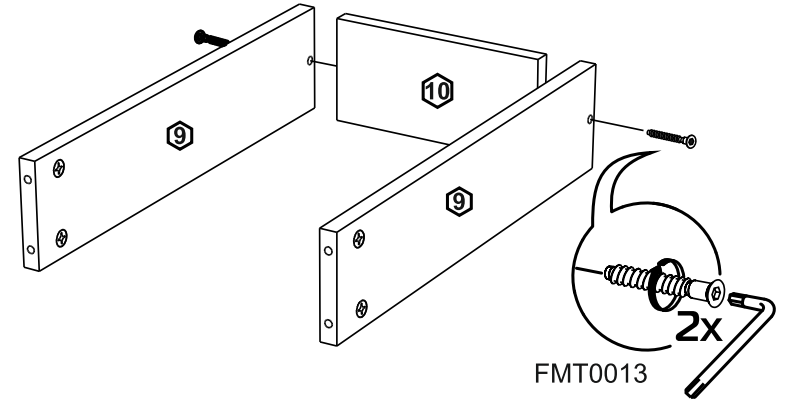

11

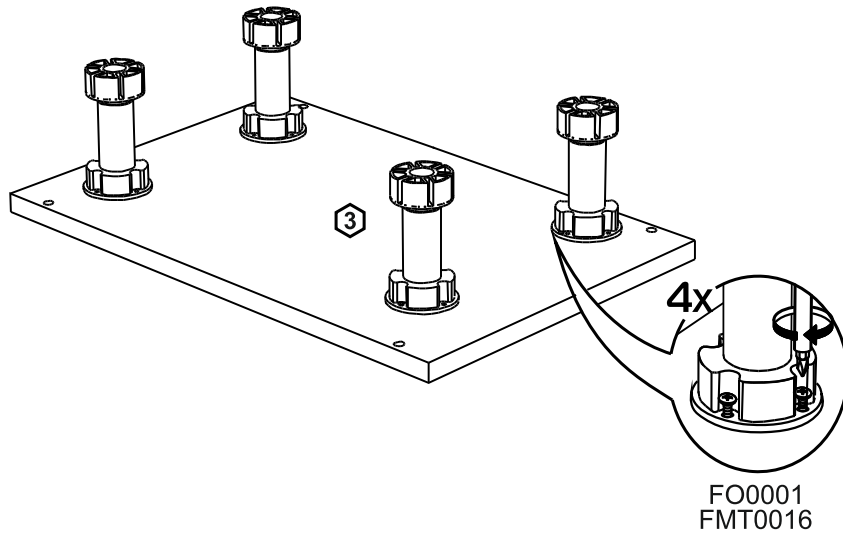

FO0001
FMT0016

30

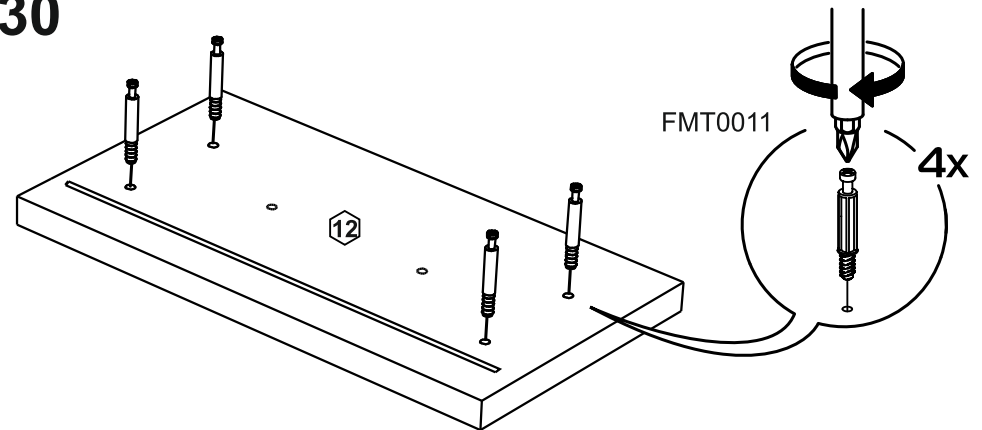

26

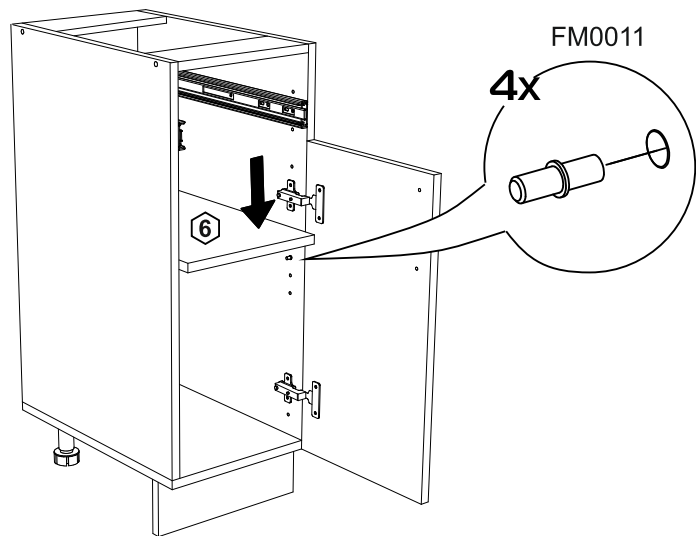

12

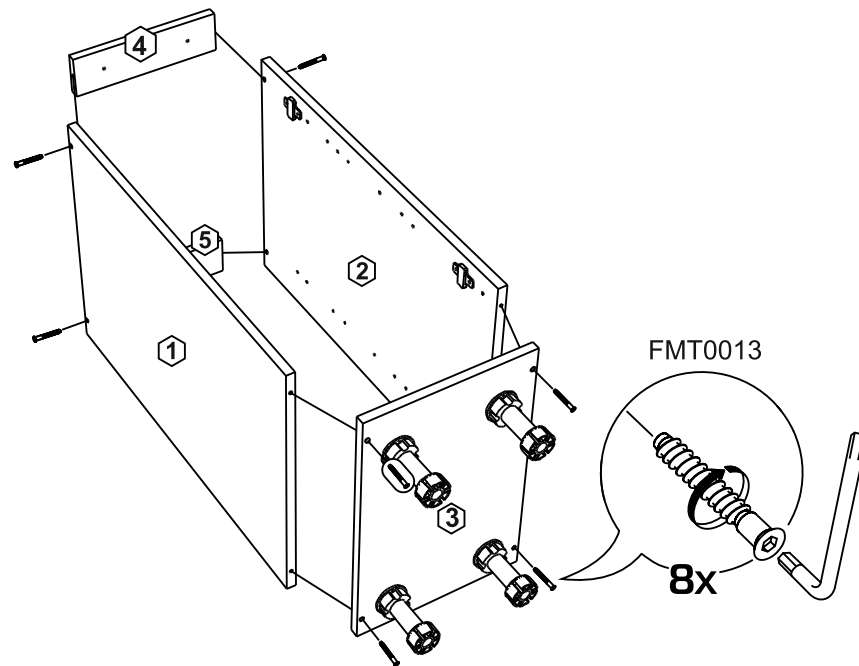

27

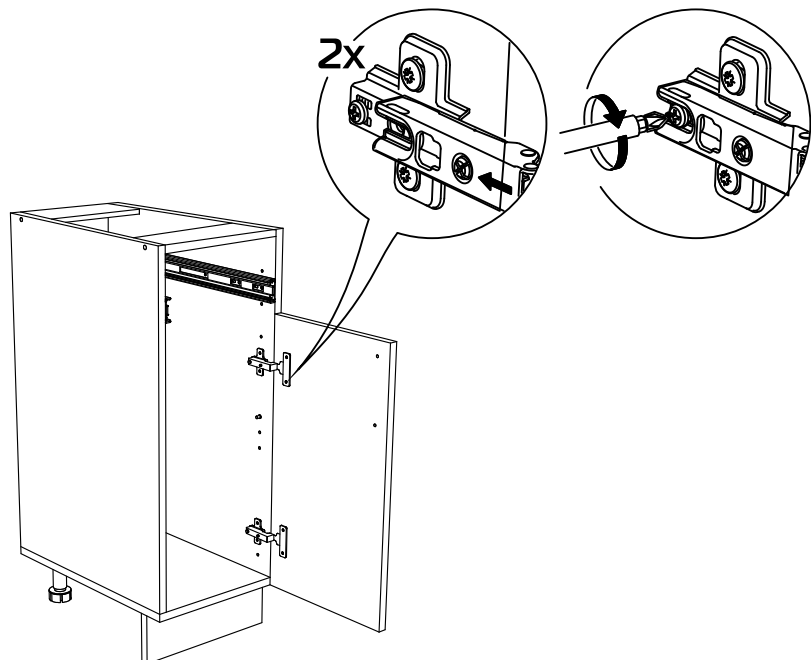

13

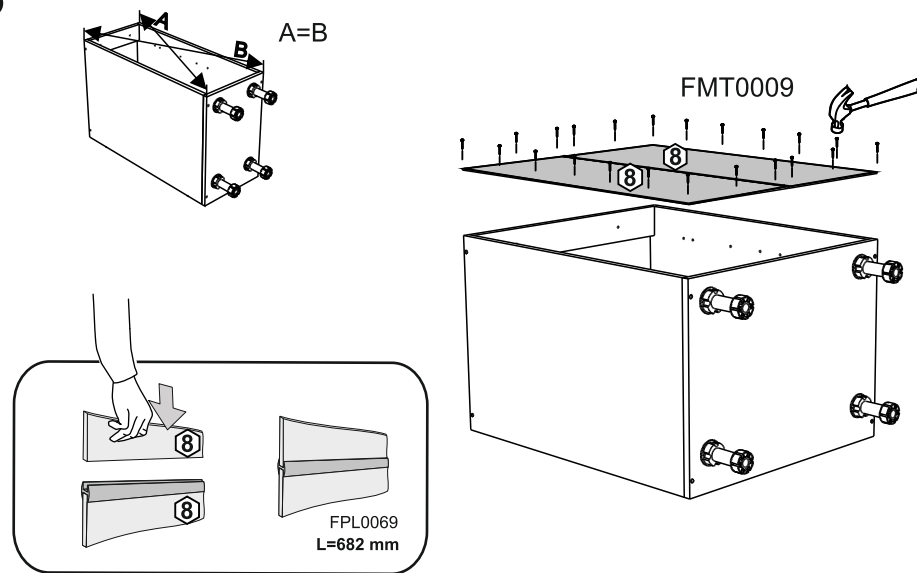

14

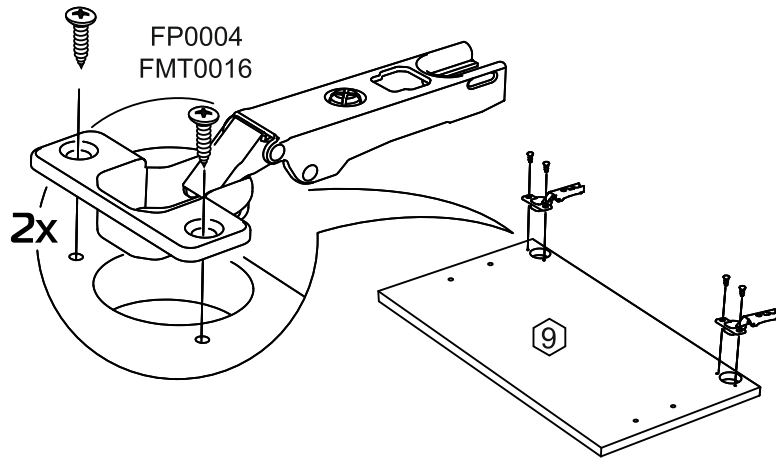

23

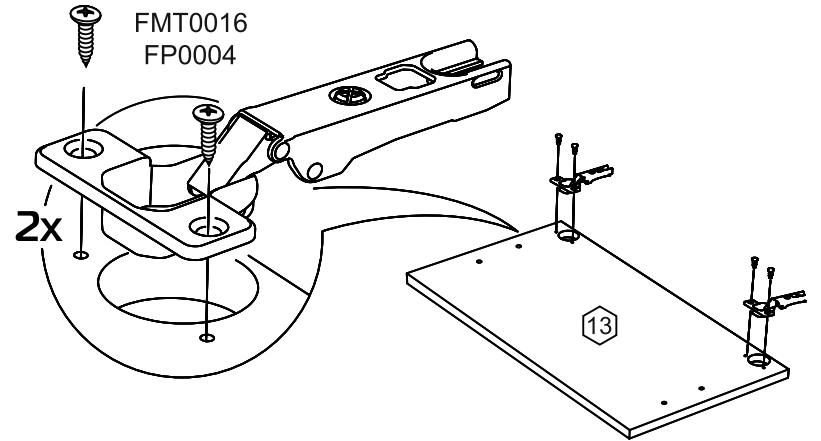

15

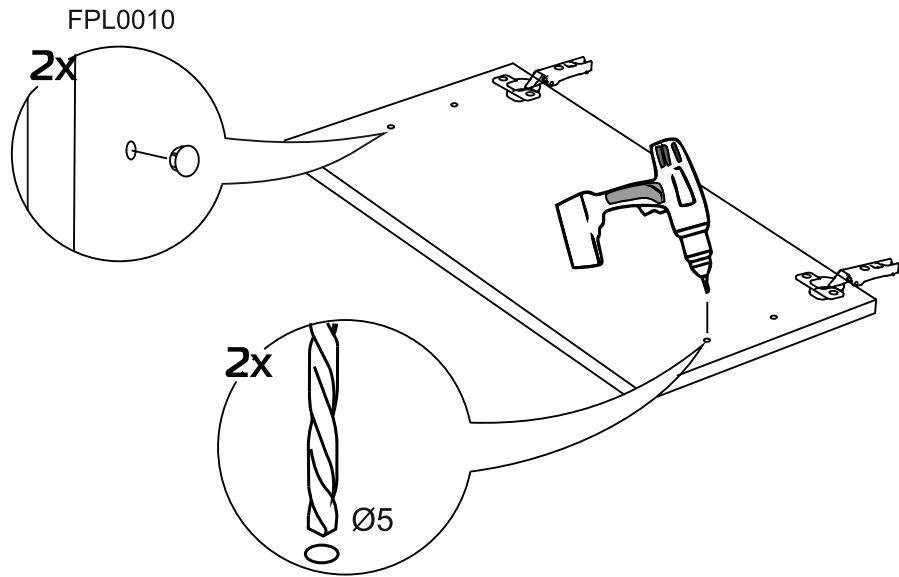

24

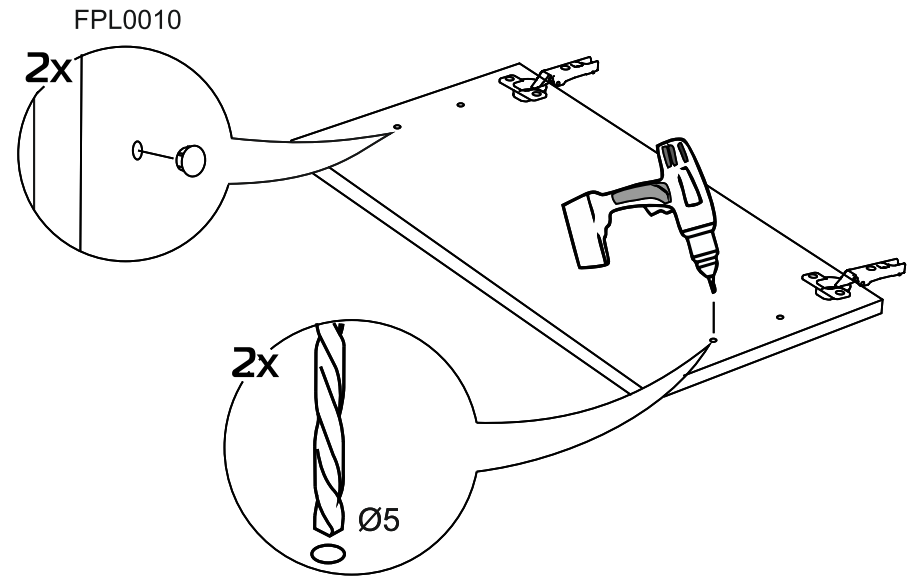

16

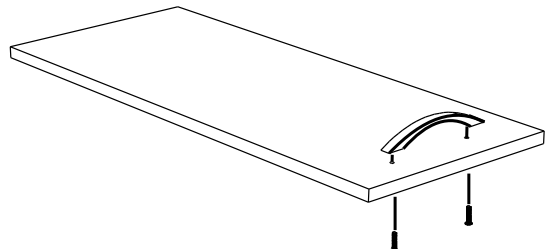

25

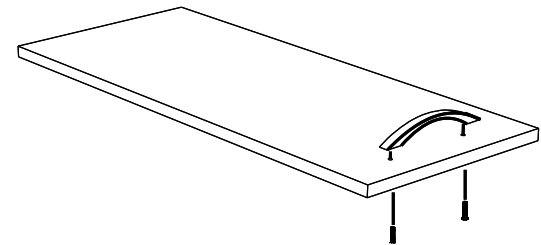

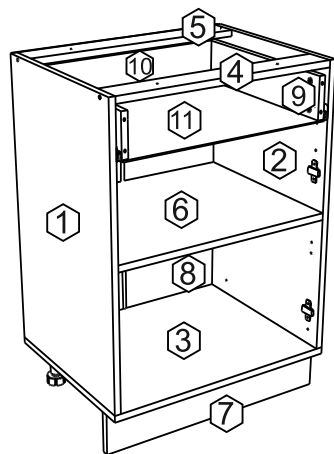

№	code	a*b	
N401			
1	N300.01	700*458	1
2	N300.02	700*458	1
3	N400.01	400*458	1
4	N400.02	368*74	1
5	N400.03	368*74	1
6	N400.04	368*458	1
7	N400.05	400*100	1
8	V800.03	715*395	1
9	N301.01	450*100	2
10	N401.01	311*100	1
11	N401.02	455*342	1
12	N401.01	156*396	1
13	N401.02	552*396	1

!Внимание! Максимальная нагрузка на ящик составляет 12 кг.
 !Remember! Total weight of goods in the drawer shouldn't be over 12 kg.

19

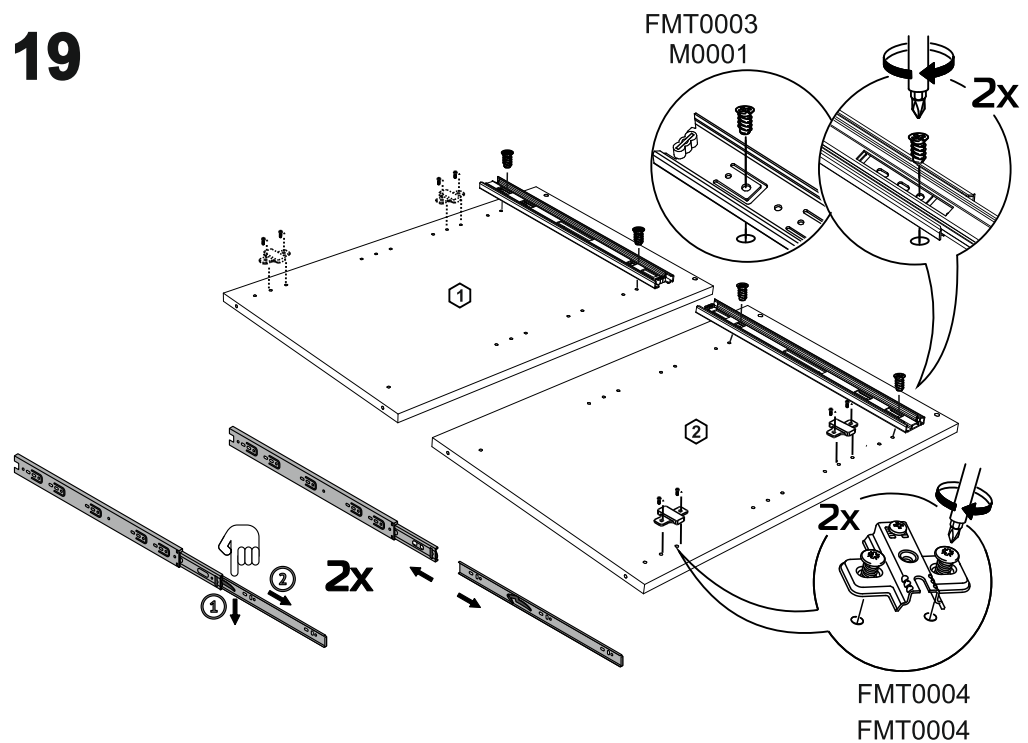

20

