

Übersetzung

## Operating instructions

Chest freezer

Read the operating instructions before switching on for the first time

Page 8

EN

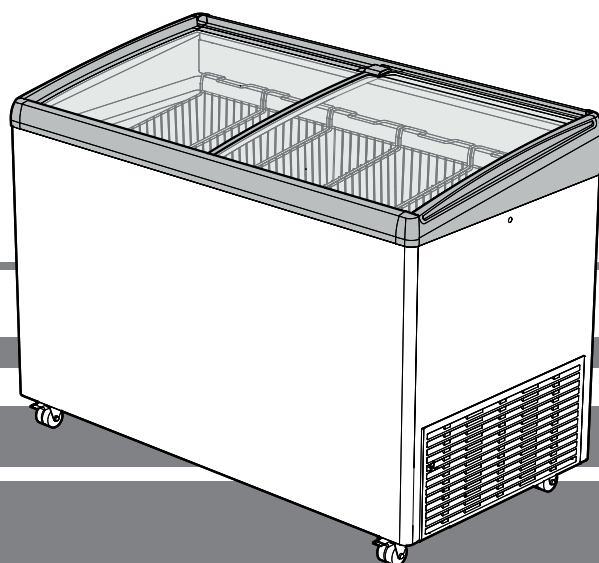

**7084 079-01**

GTI

**LIEBHERR**

## Contents of these operating instructions

These operating instructions contain the important information required to operate and control the appliance.

The operating instructions contain the following sections:

- Description of the appliance
- Commissioning
- Operation
- Shutting down the appliance
- Malfunctions/Troubleshooting
- Defrosting
- Cleaning
- Technical data
- Storing the appliance after shutting down
- Disposal
- Declaration of conformity

Read the operating instructions in full and do not use the product until you have understood the operating instructions.

## Structure of the operating instructions





### Warnings

Warnings have the following structure:

 <b>SIGNAL WORD!</b>	<b>Source of the danger.</b> Consequences of non-compliance.  ▶ Action to take to prevent the danger.
--	--

### Priority of warnings

The warnings differ depending on the type of danger as follows:

 <b>DANGER!</b>	identifies a situation involving direct danger which, if not obviated, may result in death or severe bodily injury.
 <b>WARNING!</b>	identifies a dangerous situation which, if not obviated, may result in death or severe bodily injury.
 <b>CAUTION!</b>	identifies a dangerous situation which, if not obviated, may result in minor or medium bodily injury.
<b>NOTICE</b>	identifies a dangerous situation which, if not obviated, may result in damage to property.
	identifies dangerous inflammable substances.

## Hints, notes and recommendations

- ① Provides the user with hints, notes or recommendations for using the product efficiently.

### Other symbols

Instructions to take action require the user to complete an action or a procedure. Always complete the instructions individually and in the sequence shown.

Structure of the instructions:

- ➡ Instruction for an action.

Details of results if required.

### Other applicable documents

Also refer to the additional documents supplied (e.g. delivery documents) and relevant standards and laws to ensure that you use the appliance safely and correctly.

### Archiving

Keep the operating instructions, including the other documents supplied, to hand near the appliance.

### Intended use

The appliance is suitable for storing ice cream and food that has already been frozen.

The appliance is designed for use in enclosed rooms. All other types of use are not permitted.

### Foreseeable incorrect use

Do not use the appliance for the following applications:

- Storage and cooling of medicines, blood plasma, laboratory preparations or similar substances and products subject to the Medical Devices Directive 2007/47/EC.
- Use in potentially explosive atmospheres
- Use outdoors or in areas where it is exposed to splash water or damp conditions

Incorrect use of the appliance will result in damaging or spoiling the goods stored in it.

## Safety instructions

### Dangers for the user

- ➡ Keep the operating instructions to hand near the appliance.
- ➡ Pass the operating instructions to any subsequent owner.
- ➡ To prevent injury and damage to property, the appliance should only be installed by two people.
- ➡ After unpacking it, check the appliance for signs of damage.
- ➡ Contact the supplier if it is damaged. Do not connect the appliance to the mains power supply.
- ➡ Avoid prolonged skin contact with cold surfaces (e.g. chilled/frozen products). If necessary, take safety action (e.g. gloves).
- ➡ Do not use the appliance in potentially explosive atmospheres.
- ➡ Do not allow any naked flames or other ignition sources to enter the appliance.

- Do not use electric heaters or steam cleaners, naked flames or defrosting sprays to defrost the appliance.
- Do not remove ice with sharp objects.
- Ensure that the cooling circuit is not damaged during transport and cleaning.
- If the cooling circuit is damaged, ventilate the room well and keep ignition sources away from the appliance.
- Do not eat ice cream, particularly ice lollies or ice cubes, immediately after taking them from the appliance as there is a risk of "burning" because of the very cold temperatures.



### **Incorrect handling of inflammable refrigerants**

- Ensure that the refrigerant circuit pipes will not be damaged.
- Do not allow naked flames or ignition sources to enter the appliance.
- Do not use electrical devices inside the appliance (e.g. ice cream makers, etc.).

If refrigerant escapes:

- Keep naked flames and ignition sources away from the leak area.
- Ventilate the room well.
- Notify the customer service department.

### **Incorrect installation and repair work**

- Only carry out repair and other work on the appliance when the mains plug has visibly been disconnected.
- All repairs and work on the appliance may only be carried out by customer service personnel or other trained personnel.
- The mains power cable may only be replaced by customer service personnel or other trained personnel.
- Only install, connect and dispose of the appliance as described in these operating instructions.

### **Non-intended use**

- Do not seal ventilation openings on the appliance housing or enclosure.
- When disconnecting the appliance from the mains, pull on the plug, not on the cable.
- In the event of a fault, pull out the plug or switch off the fuse.
- Ensure that food which has been stored for too long is not consumed. Dispose of food which has been stored for too long properly.

- Do not store explosive substances or spray cans with inflammable propellants (propane, butane, pentane, etc.) in the appliance. There is a danger that any leaking gases may be ignited by electrical components.
- Check that spray cans do not contain inflammable propellants before storing them in the appliance. Inflammable propellants are listed in the contents or indicated by a flame symbol printed on the container.
- Do not use the interior LED light to light the room. The interior LED light is only designed to illuminate the interior of the appliance.
- Do not use electrical devices inside the appliance (e.g. ice cream makers, etc.).
- If you have a lockable appliance, do not keep the key near the appliance or within reach of children.



### **Incorrect storage of inflammable substances**

- Do not store explosive substances or spray cans with inflammable propellants (propane, butane, pentane, etc.) in the appliance. There is a danger that any leaking gases may be ignited by electrical components.
- Check that spray cans do not contain inflammable propellants before storing them in the appliance. Inflammable propellants are listed in the contents or indicated by a flame symbol printed on the container.
- Alcoholic drinks or other vessels containing alcohol should be sealed tightly for storage.

## Description of the appliance

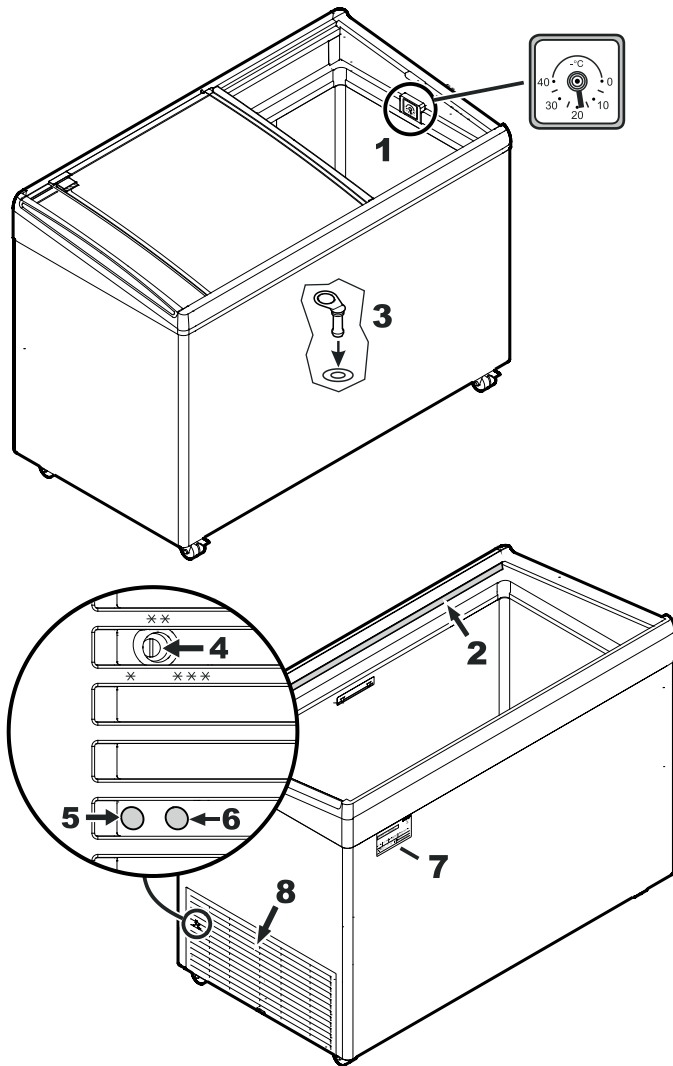

- 1 Temperature display
- 2 Interior light (depending on model and options)
- 3 Defrost water drain
- 4 Temperature control
- 5 Interior light ON switch
- 6 Interior light OFF switch
- 7 Type/Data plate
- 8 Compressor compartment ventilation grille

## Appliance dimensions

Model	Height	Width	Depth
GTI 1703	913 mm	625 mm	661 mm
GTI 2503	913 mm	835 mm	661 mm
GTI 3303	913 mm	1045 mm	661 mm
GTI 4103	913 mm	1255 mm	661 mm
GTI 4903	913 mm	1465 mm	661 mm
GTI 5803	913 mm	1675 mm	661 mm
GTI 1753	913 mm	625 mm	661 mm
GTI 2553	913 mm	835 mm	661 mm
GTI 3353	913 mm	1045 mm	661 mm
GTI 4153	913 mm	1255 mm	661 mm
GTI 4953	913 mm	1465 mm	661 mm
GTI 5853	913 mm	1675 mm	661 mm

## Accessories

- ① A cylinder lock is available to protect the appliance from unauthorised access.

To install the cylinder lock:

- ➡ Slide the lock hole cover until the opening for the cylinder lock is exposed.
- ➡ Insert the cylinder lock into the exposed opening.
- ➡ Turn the key.
- ➡ Remove the key.

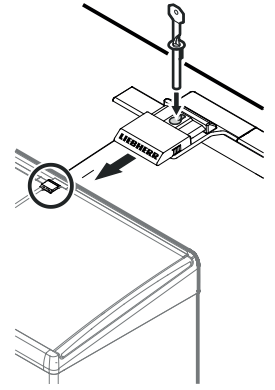

## Baskets

Baskets are available as accessories.

<b>NOTICE</b>	<b>Excessive load!</b> Damage to property. The maximum load per basket is 24 kg.
---------------	--

## Commissioning

### Unpacking

<b>⚠ DANGER!</b>	<b>Packaging material and film.</b> Danger of asphyxiation. ▶ Do not allow children to play with packaging material.
------------------	--

- ➡ Please take packaging to an official collection point.
- ➡ Clean the interior of the appliance before switching it on for the first time, see "Cleaning".

### Installing the appliance

<b>⚠ DANGER!</b>	<b>Unsuitable ratio of refrigerant to installation room volume.</b> Risk of explosion. ▶ Ensure that the room in which you install your appliance has a volume of 1 m <sup>3</sup> per 8 g of R600a/R290 refrigerant used in the appliance as set out in standard EN 378.
------------------	---

Requirements for the place of installation:

- ➡ Check that the volume of the installation room is large enough relative to the appliance's refrigerant capacity.

- ① The refrigerant capacity is shown on the type plate.

- No direct sunlight.
- No heat sources such as a stove or heater in the vicinity.
- The floor is horizontal and flat.

- ① The ventilation clearance between the edge of the chest and the floor is used to supply the refrigeration unit with cooling air.

- ➡ Ensure that the ventilation clearance between the underside of the chest and the floor is not covered.

- ➡ Ensure that the distance between the ventilation grille and wall is at least 50 mm.

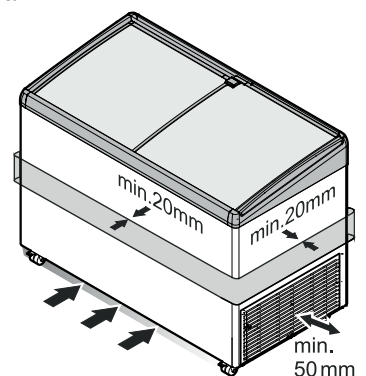

- ➔ Ensure that the area between the ventilation grille and wall is not obstructed.
- ➔ Ensure that the ventilation grille is clear of dirt and foreign bodies.
- ⓘ The appliance dissipates air through its exterior skin.
- ➔ Do not place objects right next to the exterior skin of the appliance.
- ➔ Ensure that the distance between the exterior skin of the appliance and neighbouring items is at least 20 mm.

### Electrical connection

**⚠ DANGER!** **Incorrect voltage supply.**  
Damage to property or personal injury.

- ▶ Ensure that the voltage supply complies with the specifications in the section entitled "Technical data".

- ➔ Ensure that the socket is not covered by the appliance and is easily accessible.
- ➔ Only connect the appliance to a socket protected by a fuse which has been earthed in accordance with the appropriate regulations.
- ➔ Do not connect the appliance using extension cables or extension sockets.

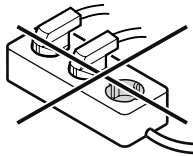

### Switching the appliance on

- ➔ Connect the appliance to the mains.
- ➔ Set the required temperature, see "Setting the temperature".

### Operation

**NOTICE** **Incorrect room temperature.**  
Damage to property and reduced cooling capacity.

- ▶ Ensure that the room temperature corresponds to the climate rating of the appliance, see "Technical data".

### Operation

#### Switching the interior light on and off

**⚠ WARNING!** **High light intensity.**  
Eye injury.

- ▶ Do not remove the light cover.
- ▶ Do not look into the light through optical lenses.

- ⓘ The light intensity of the interior LED light corresponds to laser class 1/1M.
- ⓘ The switch for the interior light is located behind the compressor compartment ventilation grille.
- ➔ Press the switch through the left opening to switch the interior light on.
- ➔ Press the switch through the right opening to switch the interior light off.

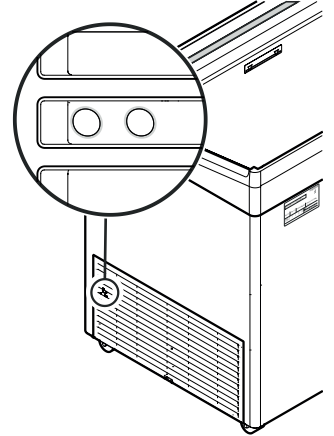

#### Maximum filling height

The stacking mark in the interior of the appliance indicates the maximum filling height.

- ➔ Do not fill the appliance with frozen items beyond the stacking mark.

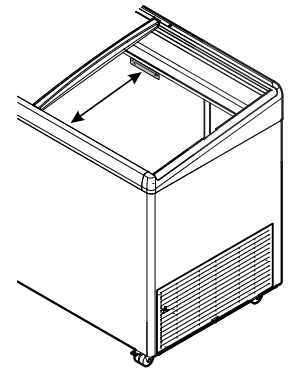

#### Setting the temperature

The temperature can be infinitely adjusted using the control knob. There are markings near the control knob. The appliance will achieve its lowest temperature when set to 3 (\*\*\*)

- ➔ To set the temperature, turn the control knob to the required setting (\* to \*\*\*) using a flat-blade screwdriver.

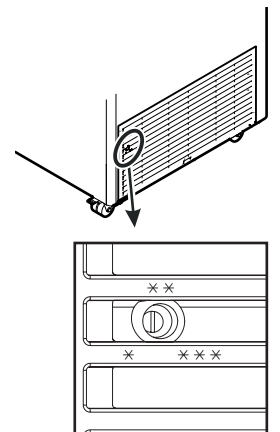

## Shutting down the appliance

### Switching the appliance off

- ➔ Pull out the mains plug or turn the temperature control knob anticlockwise until it locks in the Off position.
- ⓘ If it is switched off using the temperature control knob, the appliance is not disconnected from the mains supply.

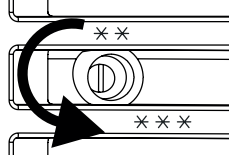

### Before shutting down the appliance for a lengthy period

- ➔ Switch off the appliance.
- ➔ Pull out the plug or switch off the fuse.
- ➔ Clean the appliance.
- ➔ Ensure that the appliance is dry inside and outside.
- ⓘ **There must be no moisture in the interior container.**
- ⓘ If the chest lid is closed when the appliance remains shut down for a lengthy period, odours will form inside it.
- ➔ Open the chest lid and secure it to prevent it being closed.
- ➔ Ensure that the ambient conditions for storage comply with the specifications in the section entitled "Storing the appliance after shutting down".

## Malfunctions/Troubleshooting

- ⓘ Contact your nearest customer service department if the appliance suffers faults which you cannot rectify.
- ⓘ To ensure that your query can be dealt with quickly, make a note of the type designation 1, service number 2 and serial number 3 on the type plate and quote them when you contact the customer service department. The position of the type plate is shown in the section entitled "Description of the appliance".

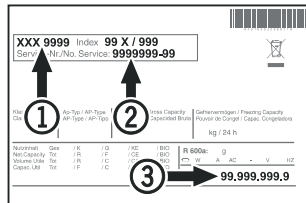

Malfunction	Possible cause	Remedy
Appliance does not cool down.	The temperature control knob is in the Off position.	Set the temperature control knob to a cooling position.
	The mains plug has been disconnected.	Connect the appliance to the mains.
	The power supply has been interrupted.	Check the power supply. Check the fuses in the power supply.
The temperature is not low enough.	Incorrect temperature set.	Set the correct temperature.
	The thermometer display is incorrect.	Check the temperature with an additional thermometer.
	Ventilation is inadequate.	Ensure that there is adequate ventilation.
	The appliance is located too close to a heat source.	Remove the heat source. Choose a suitable place of installation.

## Defrosting

After a long period of operation, a layer of frost or ice can build up on the walls of the freezer compartment. The layer of frost or ice will form more quickly if the appliance is opened frequently. A thick layer of ice increases energy consumption. You should therefore defrost the freezer regularly.

**⚠ CAUTION!** **Incorrect defrosting.**  
Injuries and damage to property.

- ▶ Do not use electric heaters or steam cleaners, naked flames or defrosting sprays.
- ▶ Do not remove ice with sharp objects. (Risk of damage to the interior walls)

- ➔ Switch off the appliance.
- ➔ Pull out the plug or switch off the fuse.
- ➔ Wrap the frozen goods in paper or blankets and store in a cool place.
- ⓘ Mop up defrost water with a sponge or cloth in appliances without a drain opening.
- ➔ Place a suitable vessel under the drain opening to collect defrost water.
- ➔ Remove the defrost water plug from the drain opening.
- ➔ Leave the lid open while defrosting.
- ➔ Mop up the remaining defrost water with a cloth after defrosting.
- ➔ Clean the appliance, see "Cleaning".

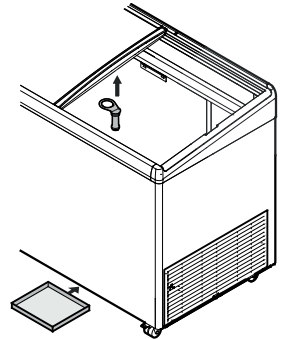

## Cleaning

**⚠ DANGER!** **Risk of electric shock if an incorrect cleaning method is used.**  
Danger of death.

- ▶ Pull out the mains plug before starting the cleaning work.

**⚠ CAUTION!** **Hot steam.**  
Injuries and damage to property.

- ▶ Do not use steam/high-pressure cleaning equipment.

**NOTICE** **Unsuitable cleaning products.**  
Damage to the appliance.

- ▶ Do not use concentrated cleaning products without diluting them.
- ▶ Only use soft cloths and an all-purpose cleaner with a neutral pH value.
- ▶ Only use food-compatible cleaning and care products on the inside of the appliance.

- ⓘ Clean the appliance every 6 months.

- ➡ Remove all the frozen items.
- ➡ Place a suitable vessel under the drain opening.
- ➡ Remove the defrost water plug from the drain opening.
- ➡ Ensure that no water flows into the ventilation grille or electrical components during cleaning.
- ➡ Clean the interior container, outer walls and equipment parts of the appliance using suitable cloths and a mixture of lukewarm water and all-purpose cleaner.
- ➡ Dry the appliance with a suitable cloth.
- ⓘ **There must be no moisture in the interior container.**
- ⓘ Dust deposits on the ventilation grille cause increased power consumption.
- ➡ Remove dust deposits from the ventilation grille.

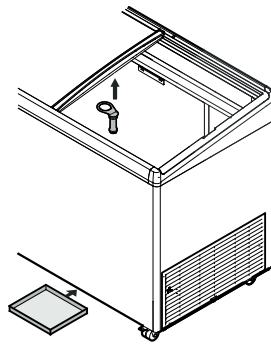

### Technical data

#### Voltage supply

- ⓘ The precise values for the correct voltage supply are shown on the type plate.

Specification	Value
Type of current	Alternating current
Fuse trip current	between 10 and 16 A

#### Noise emissions from the appliance

The noise level while the appliance is operating is below 70 dB(A) (relative noise level 1 pW).

#### Climate rating

- ⓘ The climate rating indicates at what room temperature the appliance may be operated to achieve full cooling capacity and what the maximum humidity level in the area around the appliance may be to ensure that no condensation forms on the exterior housing.

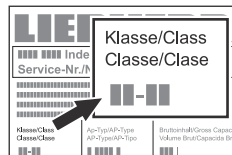

- ⓘ The climate rating is indicated on the type plate.

Climate rating	Max. room temperature	Max. relative humidity
3	25 °C	60 %
4	30 °C	55 %
5	40 °C	40 %
7	35 °C	75 %

The minimum room temperature at the place of installation is 10°C.

### Storing the appliance after shutting down

<b>NOTICE</b>	<b>Unsuitable room temperature during storage.</b> Damage to property. ▶ Ensure that the room temperature is between -10°C and +50°C.
---------------	---

- ➡ Ensure that the appliance is dry inside and outside.
- ⓘ **There must be no moisture in the interior container.**
- ➡ Ensure that the room temperature is between -10°C and +50 °C.

### Disposal

<b>NOTICE</b>	<b>Escaping refrigerant and oil.</b> Damage to the environment. ▶ Ensure that the refrigerant circuit is not damaged during the disposal process.
---------------	---

- ⓘ The appliance contains recyclable materials.
- ➡ Disconnect the appliance from the power supply.
- ➡ Cut through the mains power cable to render the appliance usable.
- ➡ Dispose of the appliance properly - not simply with unsorted household refuse.
- ➡ Ensure that the appliance is disposed of in a professional and appropriate way, in accordance with the current local regulations and laws.

### Declaration of conformity

The appliance complies with the relevant safety regulations and EU Directives 2014/30/EU and 2006/42/EG.



**Liebherr Hausgeräte Lienz GmbH**

Dr.-Hans-Liebherr-Straße 1

A-9900 Lienz

Österreich

[home.liebherr.com](http://home.liebherr.com)

