

SHTABE.DESIGN

SHTABE

ROYAL 5041
ROYAL 5041 эко

5041

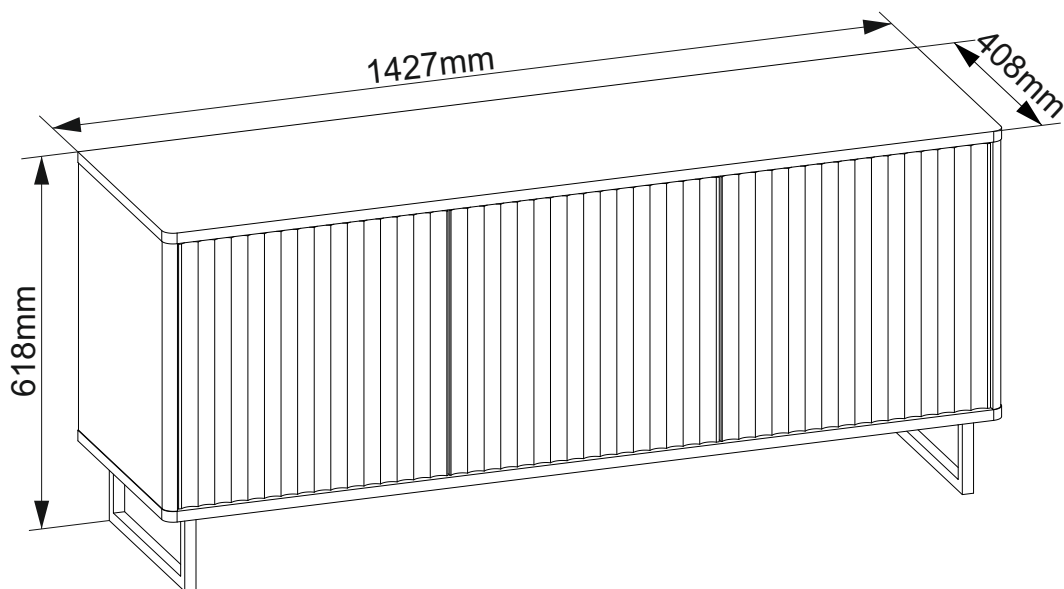

DEUTSCH Fachkundige Montage erforderlich. Unsachgemäße Montage kann zu Unfällen führen. Da es viele verschiedene Wandmaterialien gibt, sind Schrauben für die Wandbefestigung nicht beige packt. Erkundigen Sie sich ggf. beim Eisenwarenfachhandel nach geeignetem Befestigungsmaterial.

ENGLISH Assembly should be carried out by a qualified person, because wrong assembly may lead to that the furniture will topple over and cause injury or damage. As wall materials vary, screws for fixing to wall are not included. For advice on suitable screw systems, contact your local specialised dealer.

FRANÇAIS Le montage doit être effectué par une personne compétente. Un montage mal effectué peut provoquer la chute du meuble et blesser quelqu'un. Les vis et ferrures pour fixer le meuble au mur ne sont pas incluses. Choisissez des vis et ferrures adaptées au matériel de votre mur. En cas de doute, demandez conseil à un vendeur spécialisé.

ITALIANO Il montaggio deve essere effettuato da una persona competente. Se non viene effettuato correttamente, il prodotto può ribaltarsi o cadere, danneggiando persone o cose. Poiché ci sono pareti di materiali diversi, le viti per il fissaggio alla parete non sono incluse. Per scegliere gli accessori di fissaggio adatti, rivolgetevi a un rivenditore locale.

ESPAÑOL Mantaje a realizar por montador autorizado, pues un montaje erróneo puede resultar en una caída del mueble, causando daños a personas o cosas. Como hay muchas clases de materiales de pared, no se incluyen los tornillos de montaje. Para sugerencias sobre sistemas de colocación adecuados, ponte en contacto con tu especialista más cercano.

PORTUGUES A montagem deverá ser realizada por uma pessoa qualificada, pois uma montagem incorreta pode povocar a queda do móvel e causar lesões ou estragos. Como os materiais de parede variam, os parafusos para fixar à parede não estão incluídos. Para mais conselhos sobre o sistema de parafusos adequado, consulte o seu retalhista local especializado.

NEDERLANDS De montage dient te worden uitgevoerd door een vakbekwaam iemand. Foutieve montage kan ertoe leiden dat het meubel omvalt, waardoor er persoonlijk letsel of schade kan ontstaan. Omdat er veel verschillende wandmaterialien bestaan, zit er geen wandbeslag bijgesloten. Voor advies over geschikt wandbeslag, neem contact op met de vakhandel.

SVENSKA Monteringen ska utföras av kunnig person, då feilmontering kan leda till att möbelen faller och skadar någon eller något. Eftersom det finns många olika väggmaterial, medföljer ej skruvar för vägginfästning. För råd om lämpliga skruvsystem, kontakta din lokala fackhandlare.

БЪЛГАРСКИ Необходим е монтаж от специалист. Неправилният монтаж може да причини злополуки. Тъй като има много различни стенини материали, винтовете за стенин монтаж не са приложени. При нужда се информирайте в специализираните железарски магазини за подходящия крепежен материал.

SLOVENSKO Potrebna je strokovna montaža. Nepravilna montaža lahko vodi do nezgod. Ker obstajajo različni stenski materiali, vijaki za pritrditev na zidu niso priloženi. Za ustrezen pritrditveni material se po potrebi pozanimajte v strokovni trgovini z železnino

DANSK Monteringen skal udføres af en kyndig person, da fejlmontering kan fører til at møblet falder og skader nogen eller noget. Eftersom der findes mange forskellige vægmateriale, medfølger der ikke skruer til vægmontering. Ønsker du råd omkring forskellige skruestystemer, kontakt din lokale faghandler.

ČESKY Montáž by měla být provedena kvalifikovanou osobou – nesprávné provedení může vést k převrnutí nábytku a způsobit úraz nebo destrukci. Pro různé zdicí materiály nejsou šroubky a uchycení obsaženy v balení. O vhodném připevnění se porad'te s odborným prodejcem.

SLOVENSKY Montáž by mala byť prevedená kvalifikovanou osobou. Pri nesprávnej montáži môže dôjsť k pádu nábytku, a tým aj k prípadnému úrazu. Skrutky a úchytky na rôzne typy stien nie sú súčasťou balenia. Ak si nie ste istí, obráťte sa na kvalifikovanú osobu.

POLSKI Montaż powinien być przeprowadzany przez wykwalifikowaną osobę, ponieważ złe zmontowanie może spowodować zniszczenie mebla lub może wyrządzić szkodę domownikom. Ponieważ w każdym pomieszczeniu ściany mogą być wykonane z innego materiału, komplet nie zawiera żadnych wkrętów ani umocowań. Aby zasięgnąć porady w kwestii wyboru odpowiednich wkrętów skontaktuj się z lokalnym sklepem specjalistycznym.

MAGYAR Az összeszerelést ajánlatos képzett szakemberre bízni, mert a helytelen összeszerelés következtében a bútor felborulhat és sérülést okozhat. Mivel a fal anyaga lakásonként/otthononként eltérő lehet, a rögzítéshez szükséges csavarokat a csomag nem tartalmazza. A megfelelő csavar kiválasztásáért kérj tanácsot az áruházban a zakképzett személyzettől.

РУССКИЙ Сборка должна производиться специалистом, так как неправильная сборка может привести к опрокидыванию мебели, что может повлечь за собой ущерб или телесные повреждения. Так как материалы стен различаются, шурупы для фиксации к стене не прилагаются. Для выбора подходящих крепежных средств обратитесь в местный специализированный магазин.

ROMÂNĂ Necesită montaj de specialitate. Montarea necorespunzătoare poate cauza accidente. Deoarece există multe materiale diferite pentru pereți, șuruburile pentru fixarea pe perete nu sunt incluse în ambalaj. Solicitați informații eventual de la magazinul specializat în articole de feronerie privind materialul de prindere adecvat.

HRVATSKI Potrebna stručna montaža. Nestručna montaža može dovesti do nesreća. Budući da postoje različiti zidni materijali, vijci za pričvršćenje na zid nisu uključeni. Raspitajte se npr. u željezarnji o prikladnim materijalima za pričvršćenje.

TÜRKÇE Uzman kişilerce montaj yapılması gereklidir. Usulüne uygun yapılmayan montaj kazalara yolaçabilir. Çok sayıda duvar malzemesi olduğundan duvara sabitleme vidaları beraberinde verilmemiştir. İcabi halinde demirden yapılmış araç gereç satan dükkanlardan uygun sabitleme malzemeleri hakkında bilgi alın.

עברית מומלץ להרכיב את המוצר ע"י איש מקצוע. הרכבה לא נכונה עלולה לגרום לתאונות. עקב השוני בסוגי הקירות, ערכת ברגים לא מצורפת. לבחירת הברגים המתאימים יש להתייעץ עם בעל מקצוע.

Ошибки при сборке*

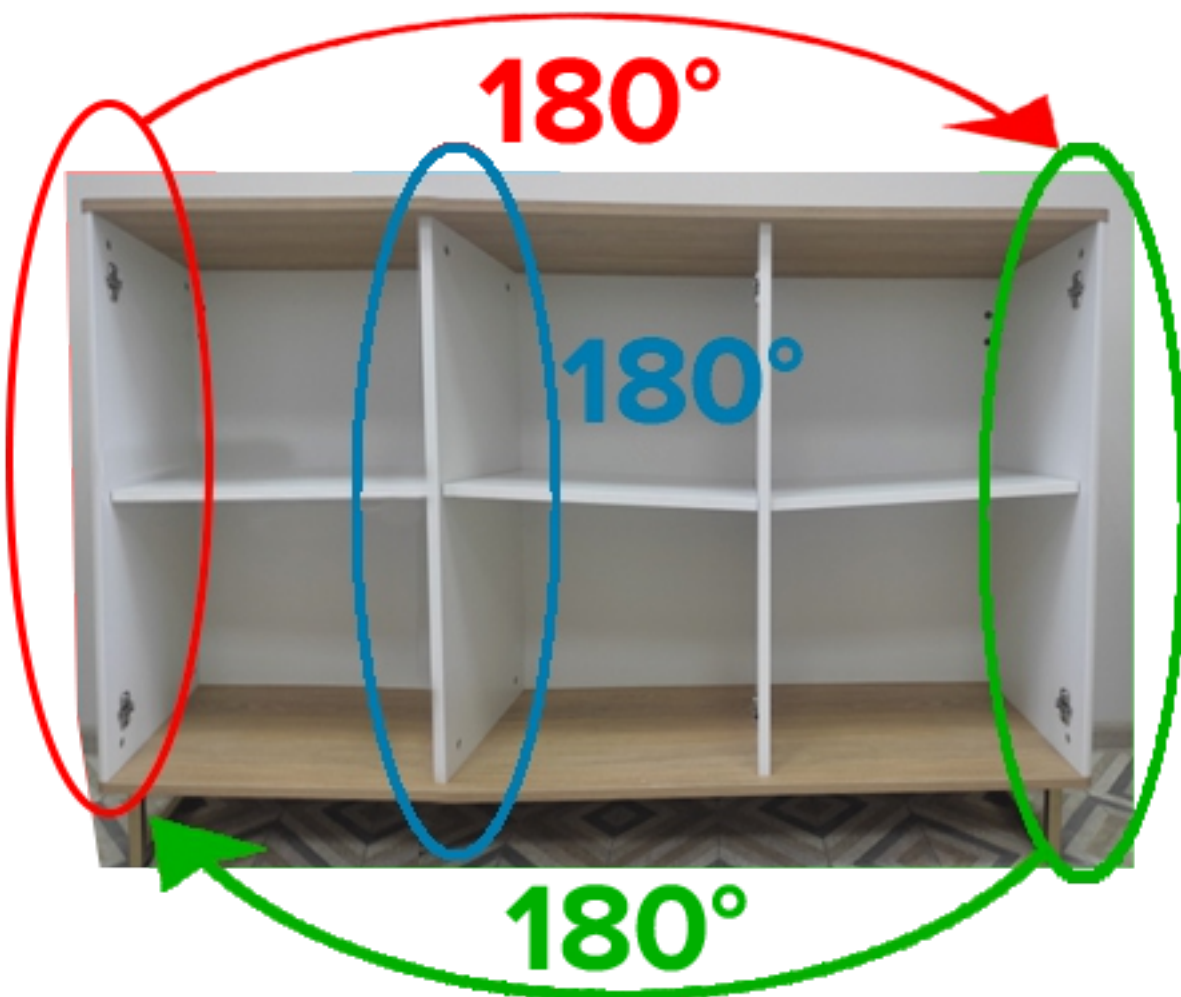
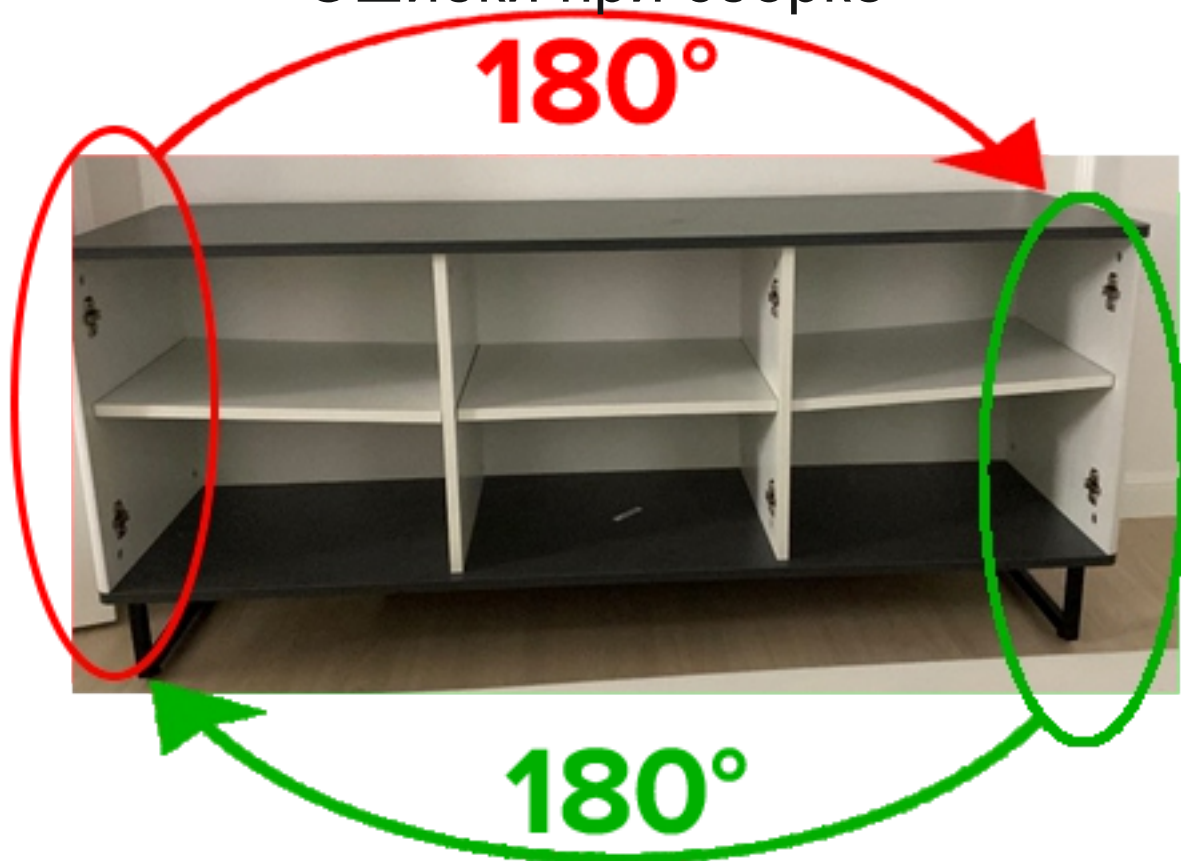

* с 10.01.2023 г. фабрика изготавливает универсальные боковины и перегородки

Service • Dienstverlening • Serwis • Servis • Сервисная служба

Name • Naam • Nazwa • İsim • Название

Nr. • No. • Номер

Тур • Туре • Tür • Тип

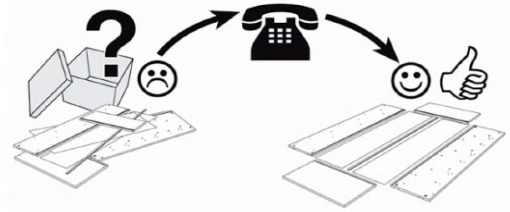
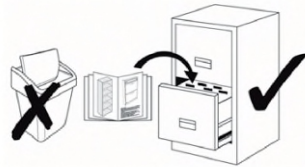

5041 эко

1	1417	408	16	1x
2	1417	408	16	1x
3	452	407	19	1x
4	452	407	19	1x
5	452	362	18	1x
6	452	362	18	1x
7	352	447,5	18	2x
8	352	437	18	1x
9	447	455	19	3x
10	470	467,5	3	2x
11	470	456	3	1x
12	350	130	20	2x
13	1294	228	20	1x

5041

1	1417	408	18	1x
2	1417	408	18	1x
3	452	407	19	1x
4	452	407	19	1x
5	452	362	18	1x
6	452	362	18	1x
7	352	447,5	18	2x
8	352	437	18	1x
9	447	455	22	3x
10	470	467,5	3	2x
11	470	456	3	1x
12	350	130	20	2x
13	1294	228	20	1x

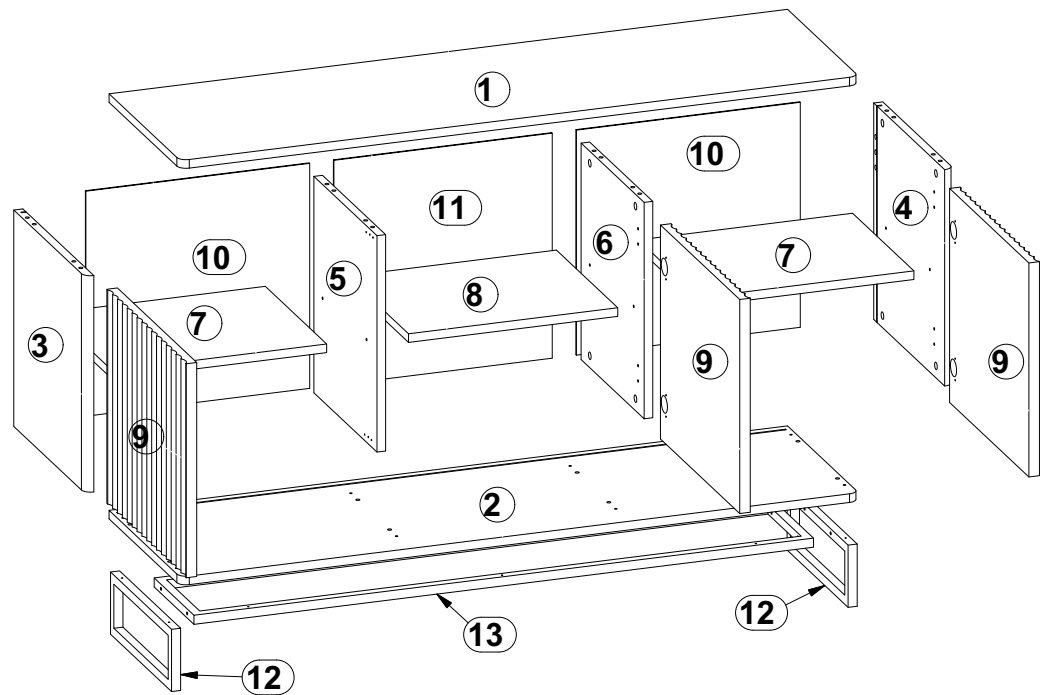

K16 a1 x4	K9,5 a2 x2	b1 x6	D5mm d1 x12	f1 x16	r1 x16	r42 x16
s2 x16	z1 x1	Ø3,5x16mm p51 x26	l2 x16	20x13x3,5/1mm n108 x4	n101\L x1	n101\R x1
Ø3x20mm p1 x2	n174 x2	n54\5 x3	o68 x4	j63 x4	xx x4	
n54\1 x3	n54\2 x3	n54\3 x3				

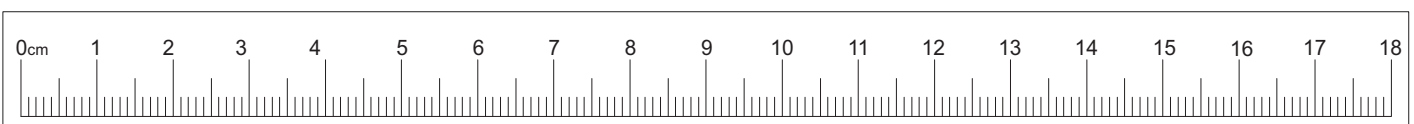

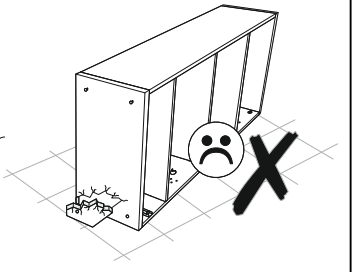
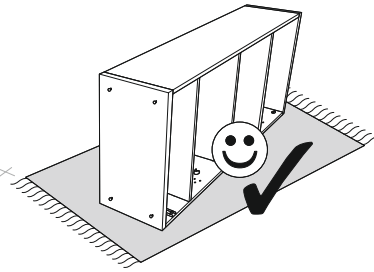
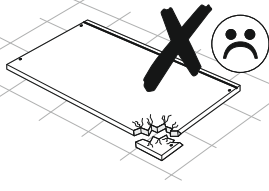
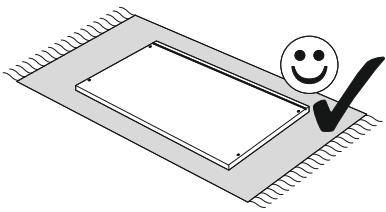

1

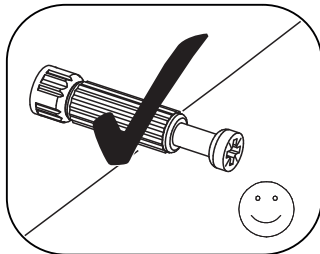
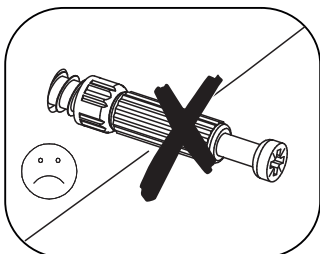
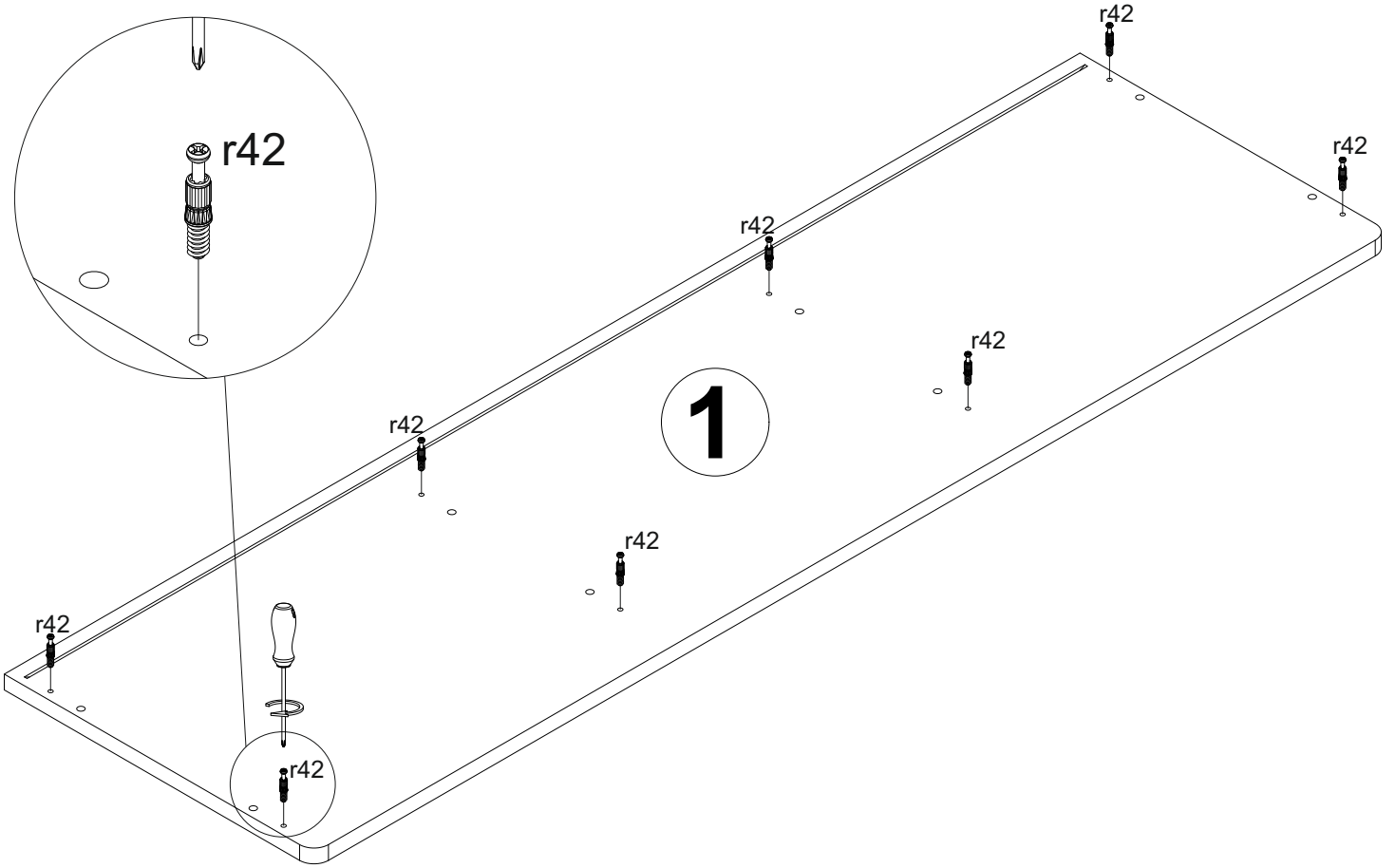
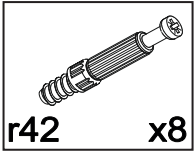

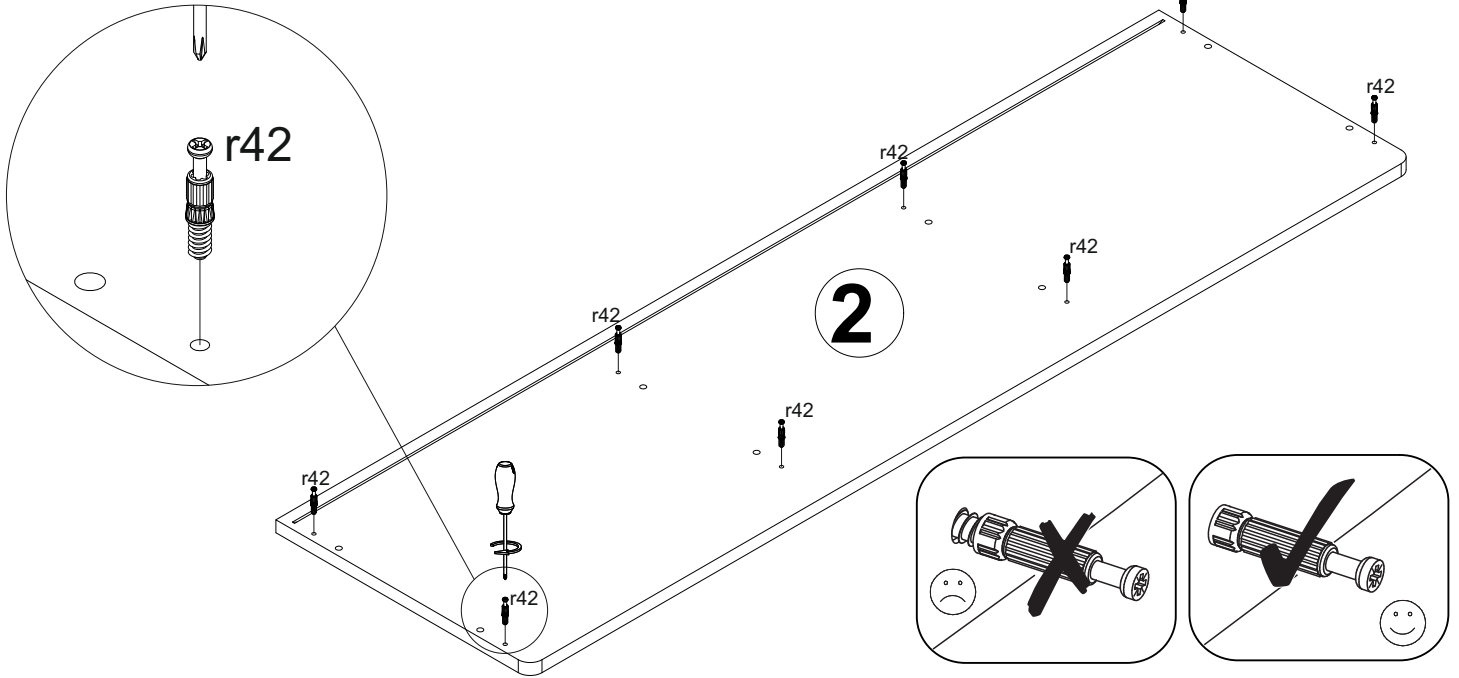
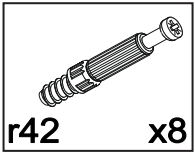

2



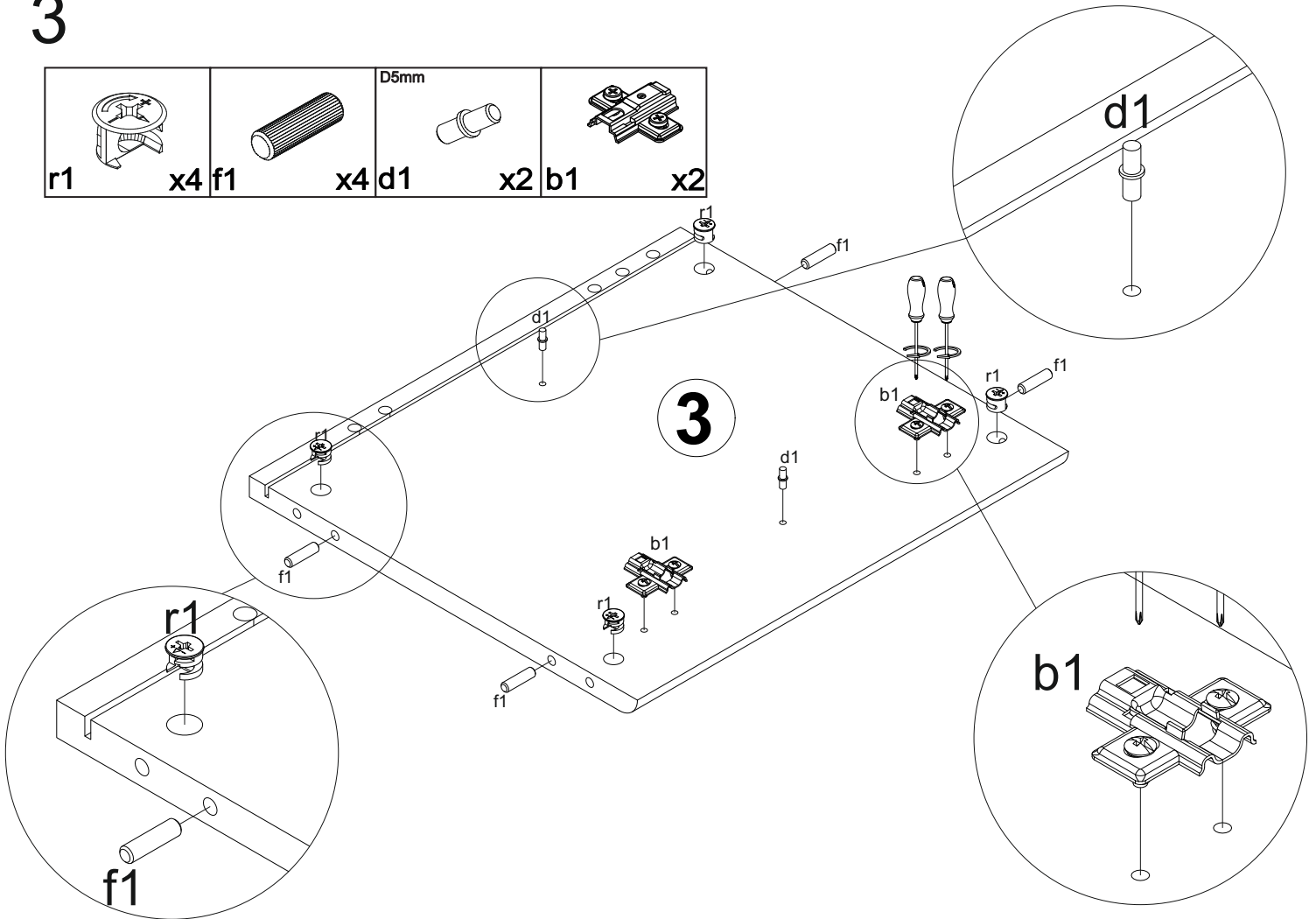
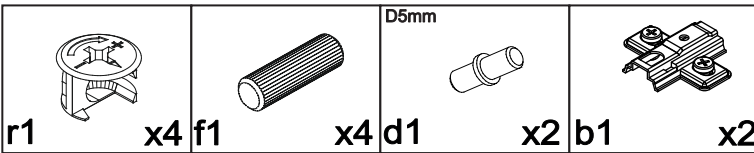

3

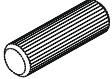

6

			
r1	x4 f1	x4 d1	x4 b1

D5mm

	
x2	x2

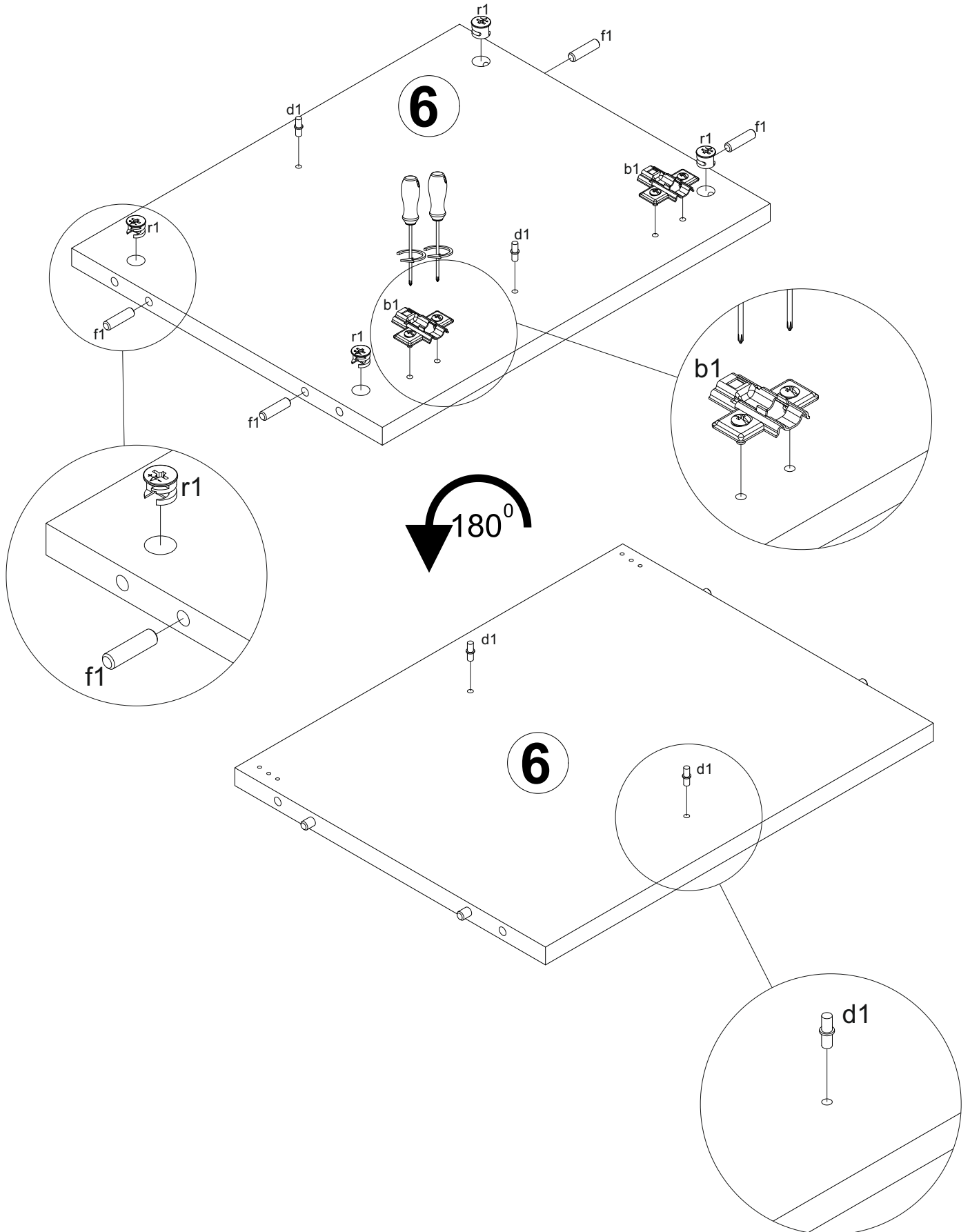

4

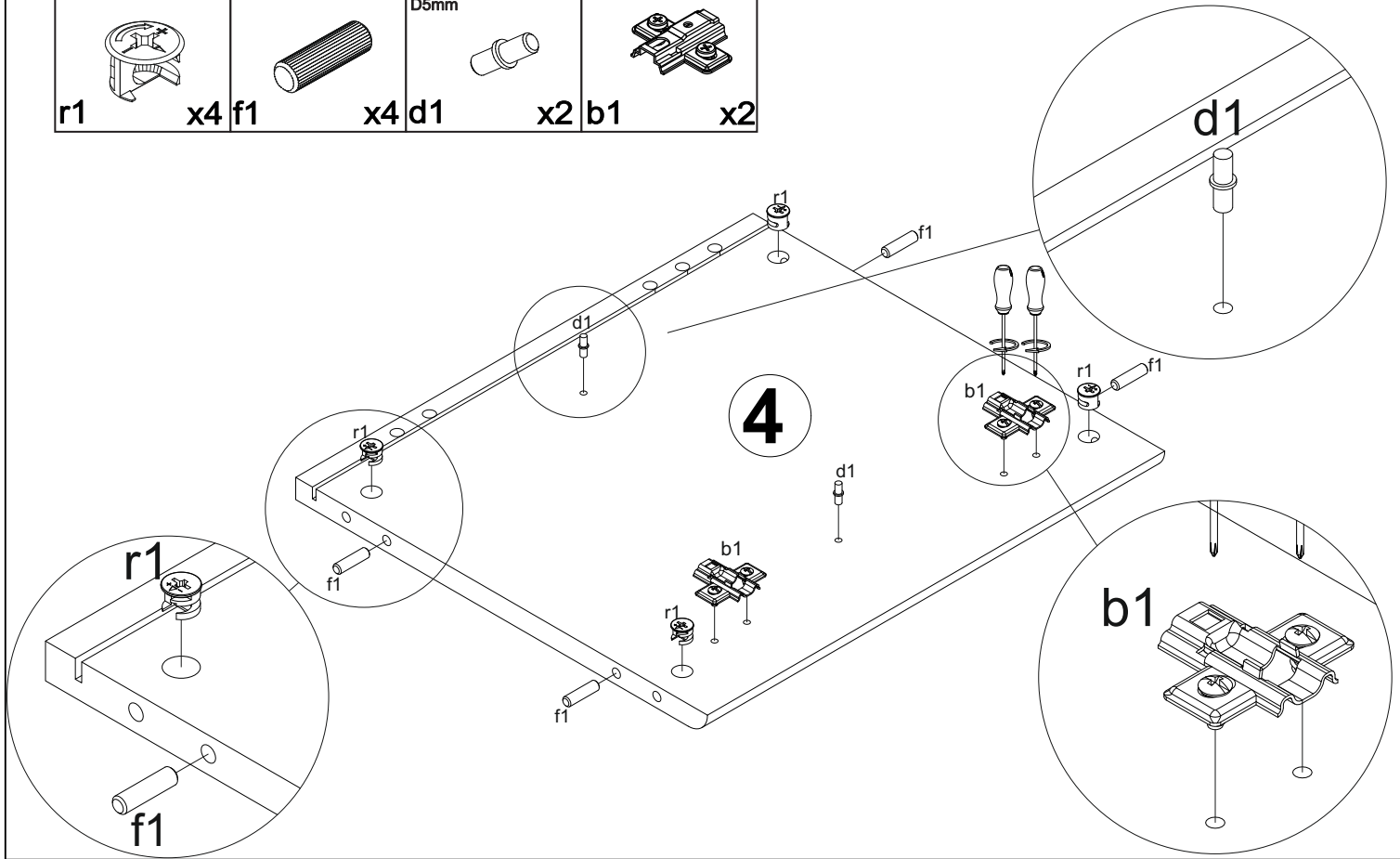
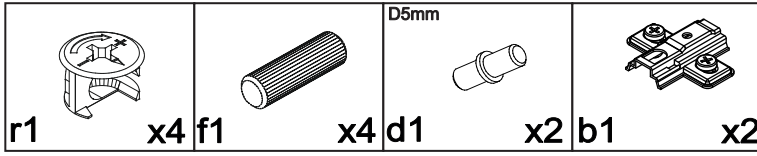

5

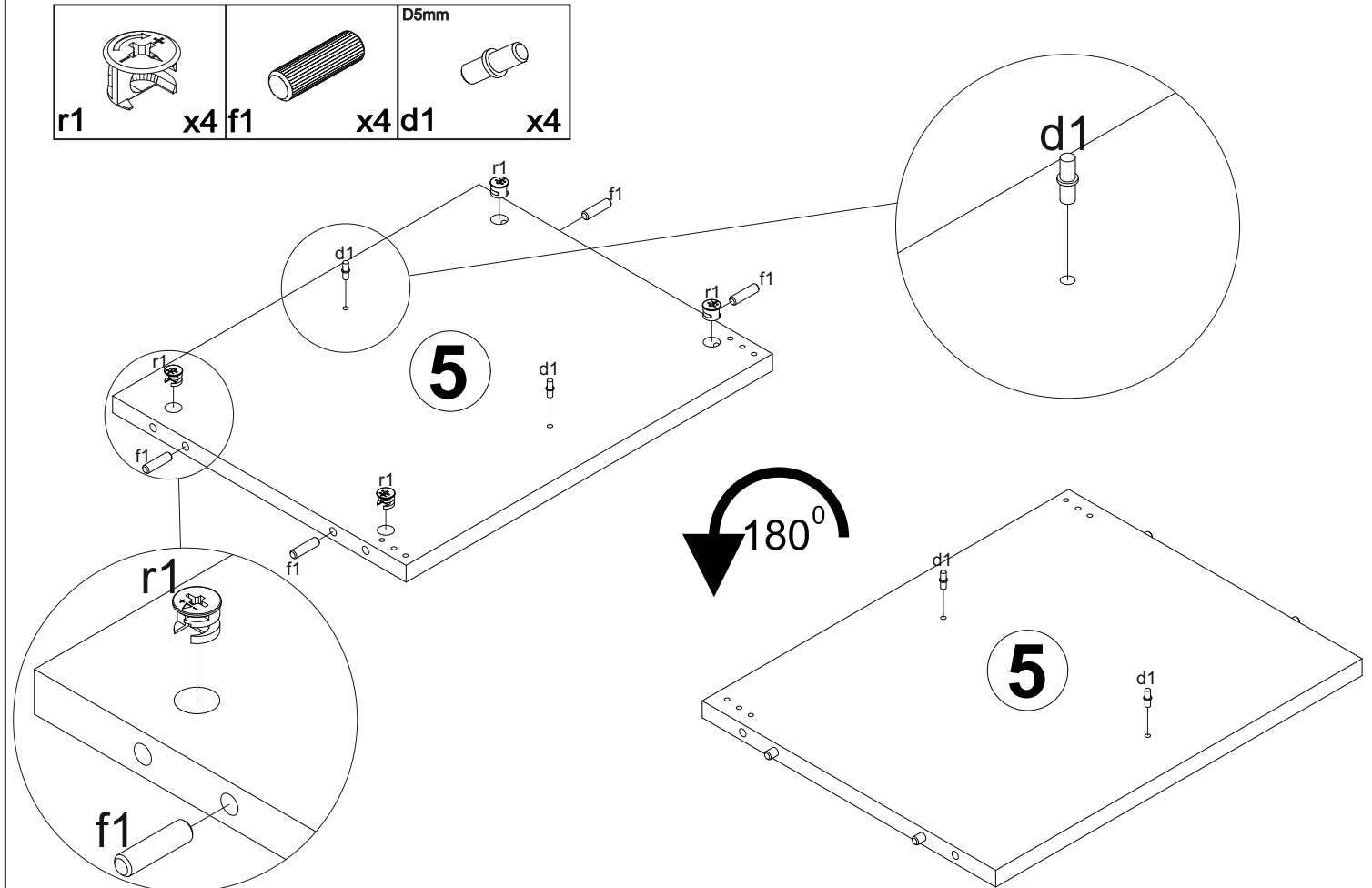
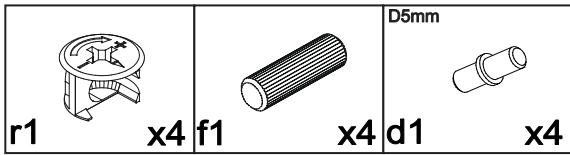

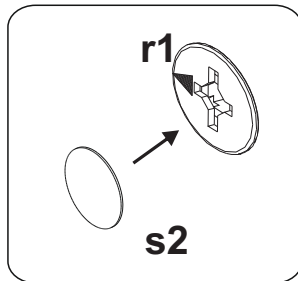
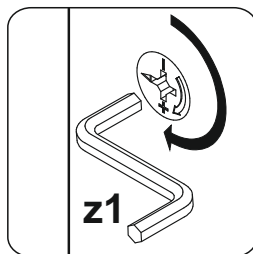
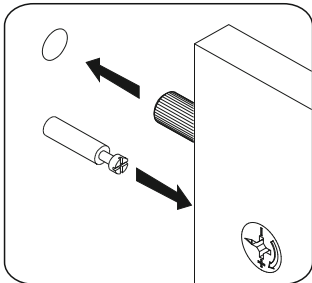
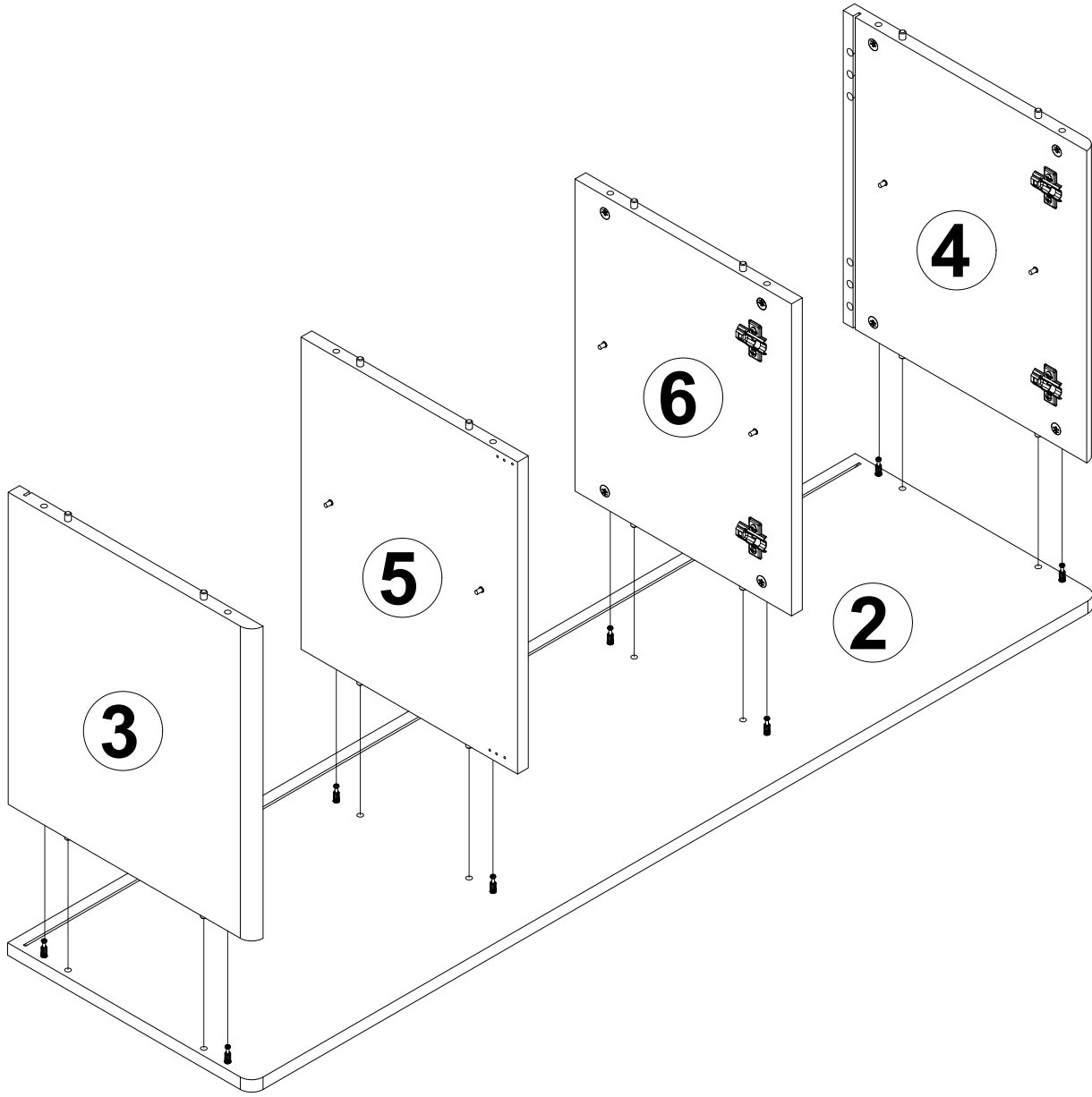
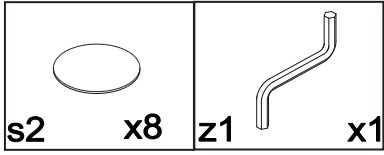

7

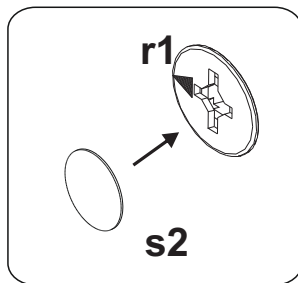
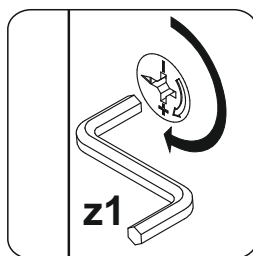
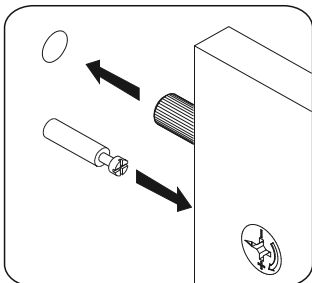
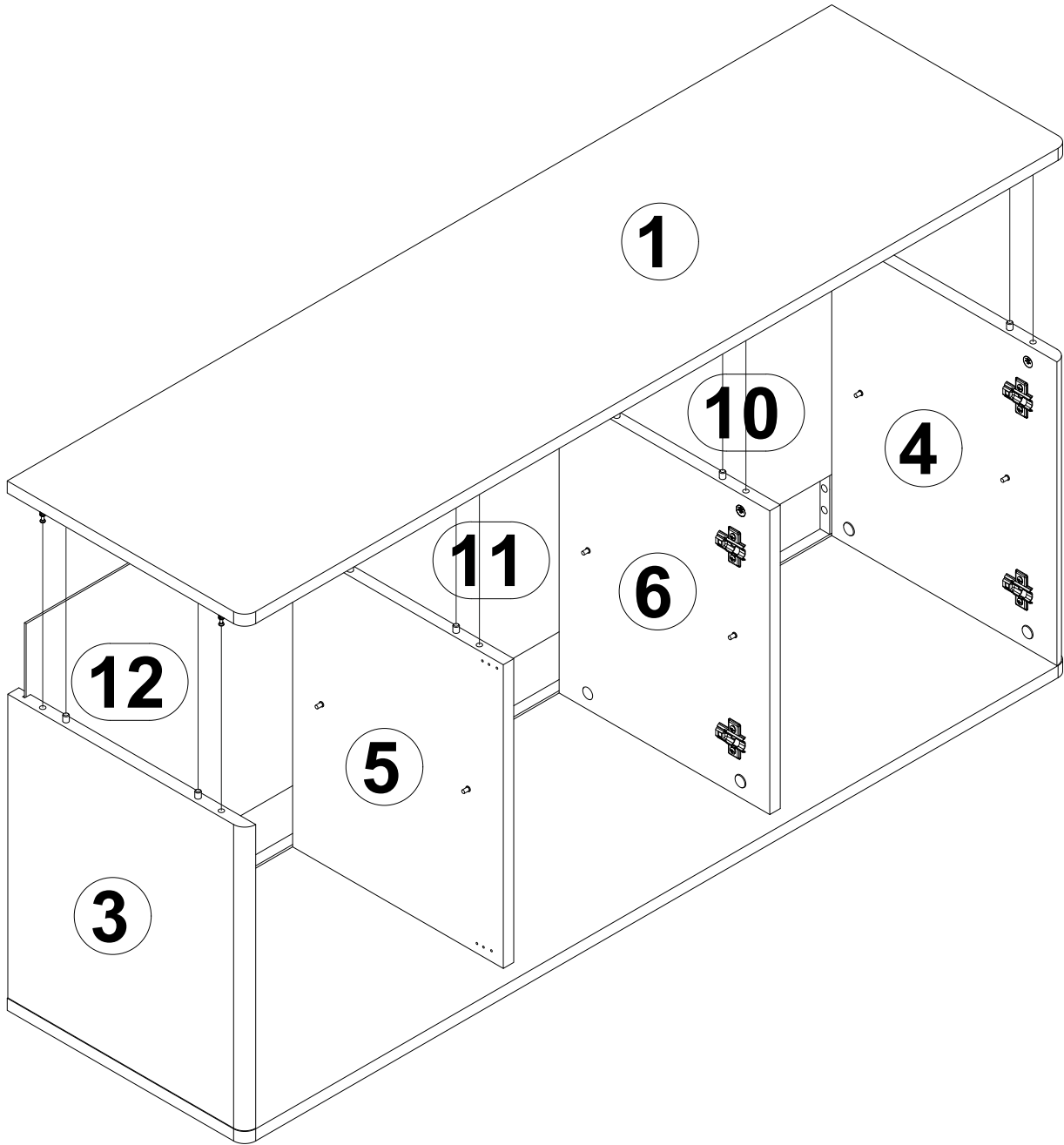
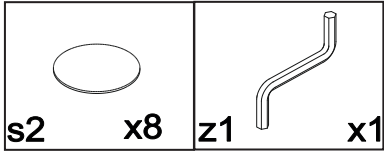

8



11

	20x13x3,5/1mm		Ø3,5x16mm		
I2	x16	n108	x4	p51	x4

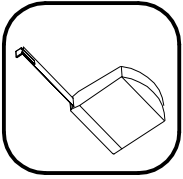

X = Y

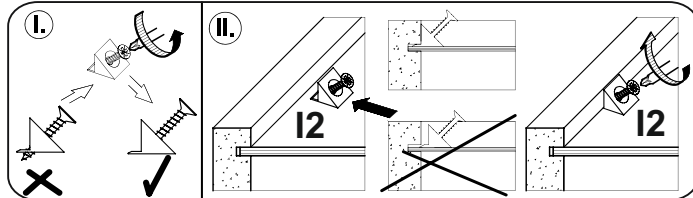
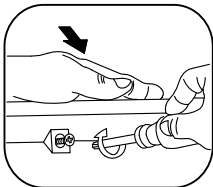
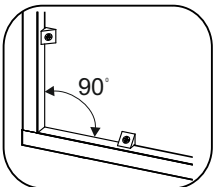
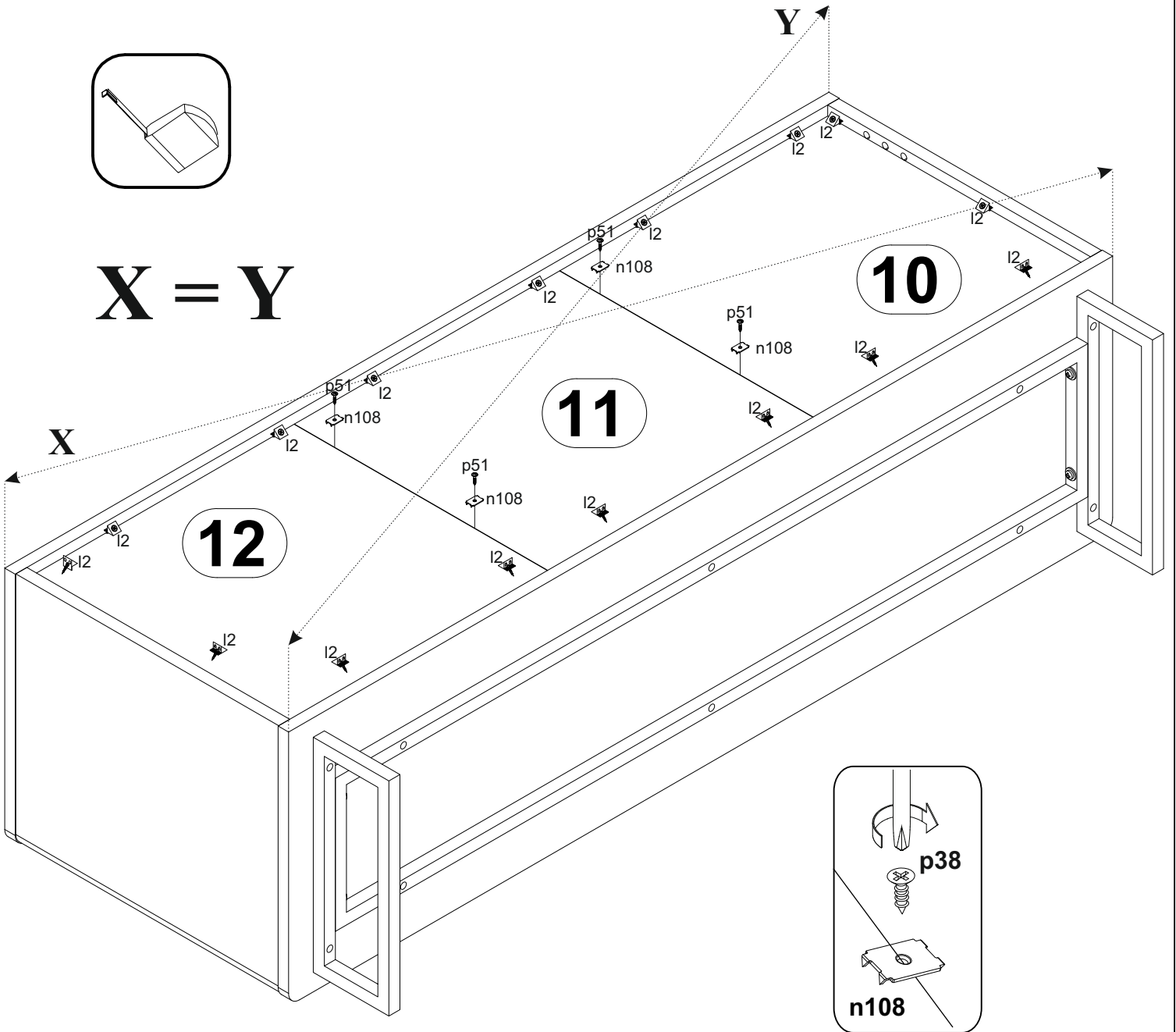

12

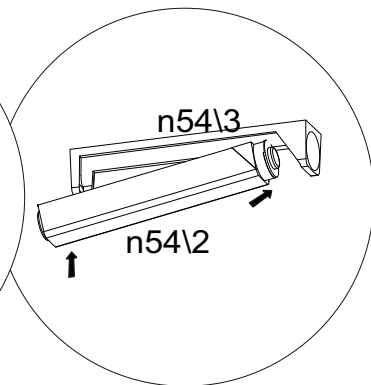
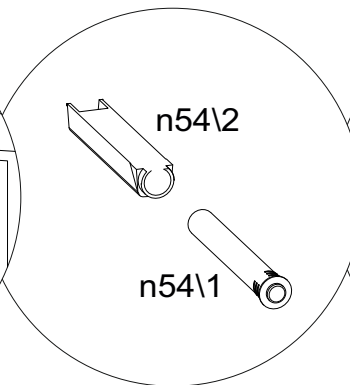
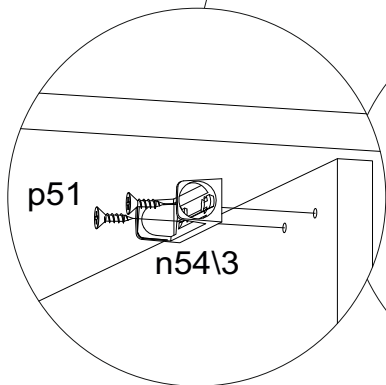
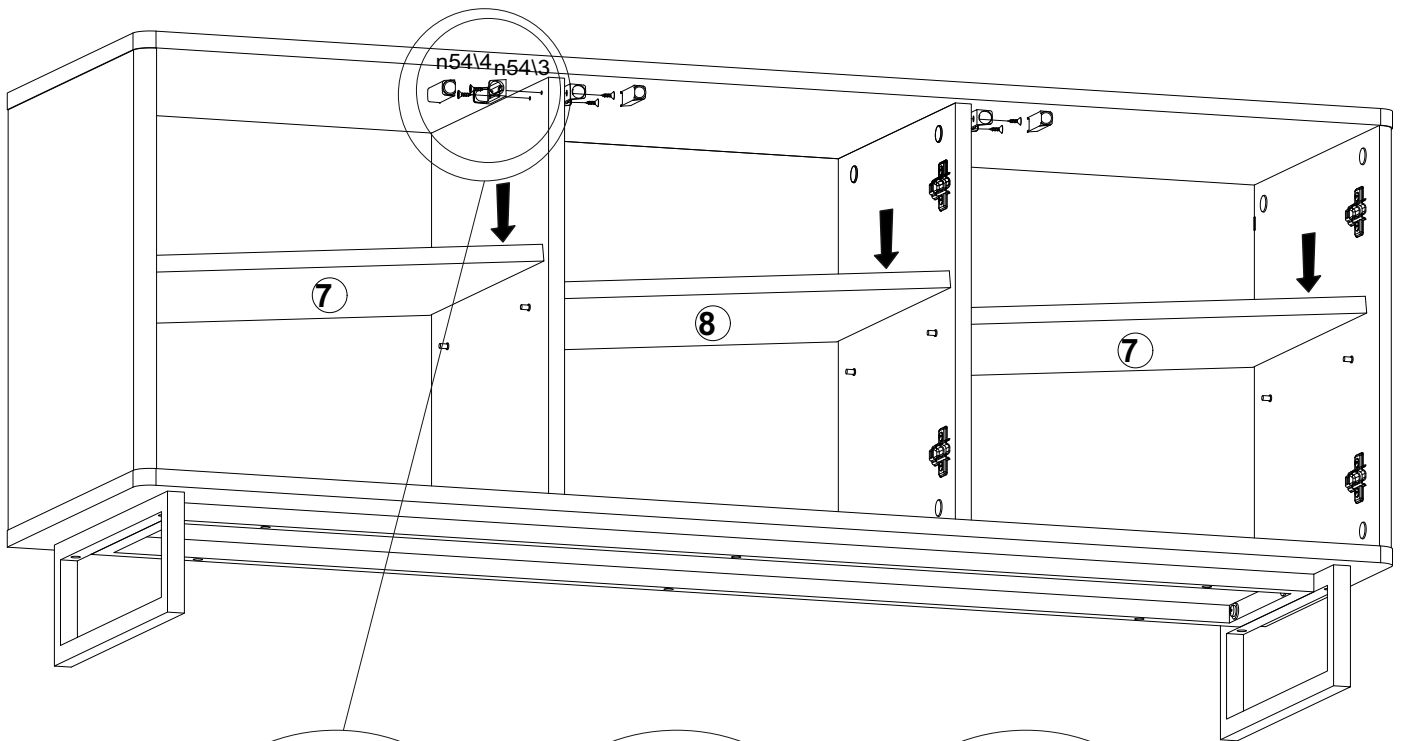
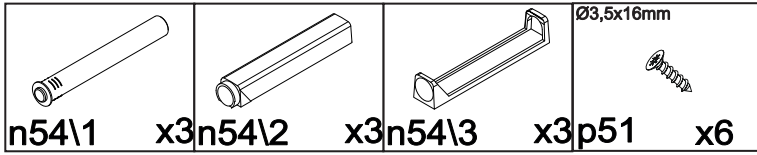

13

K16					
	a1	x4 a2	x2 p51	x12 n54/5	x3

!!! ВНИМАНИЕ !!!

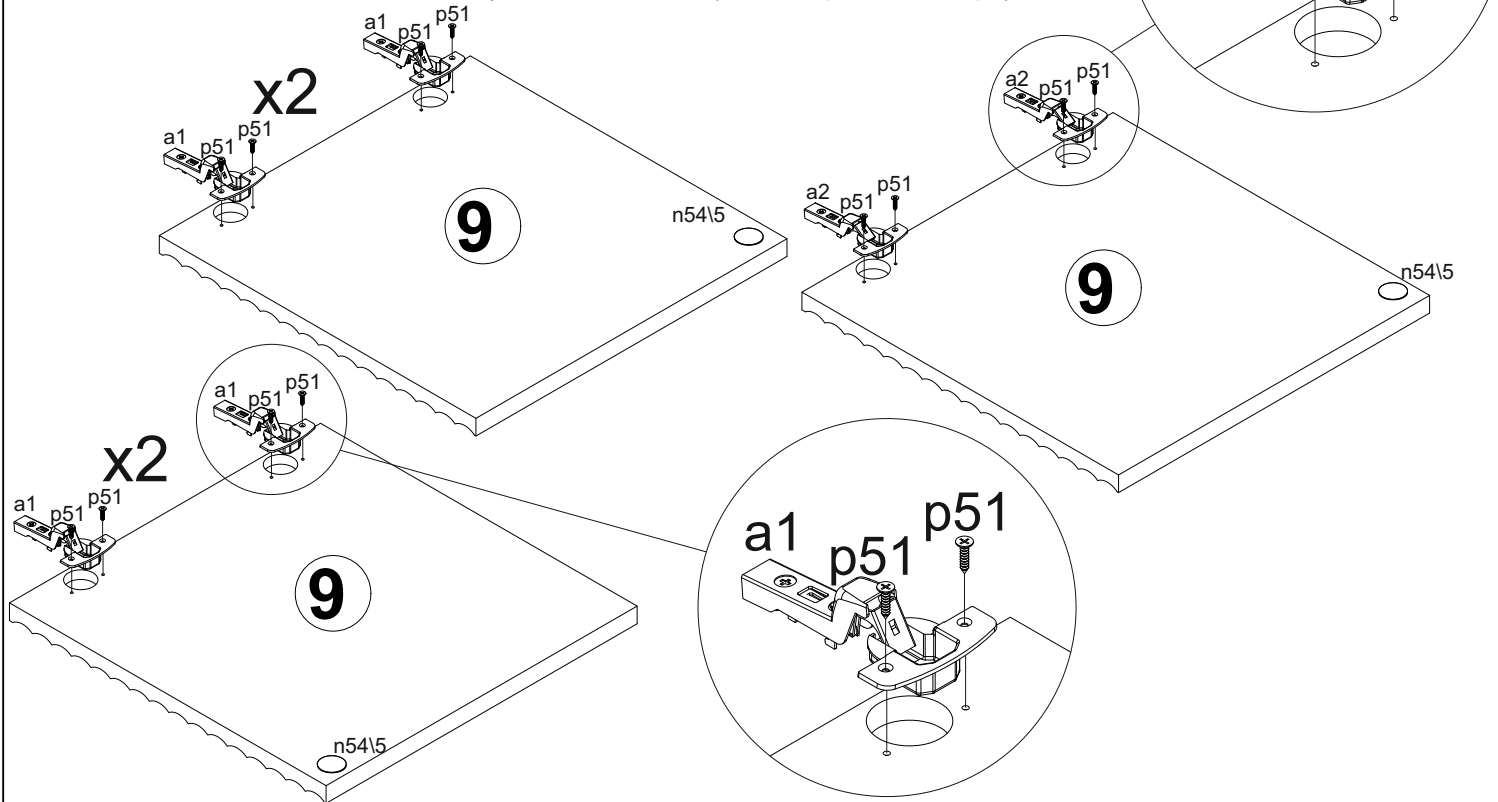

a1 - внутренняя петля (для боковых дверей)
 a2 - полунакладная петля (для центральной двери)

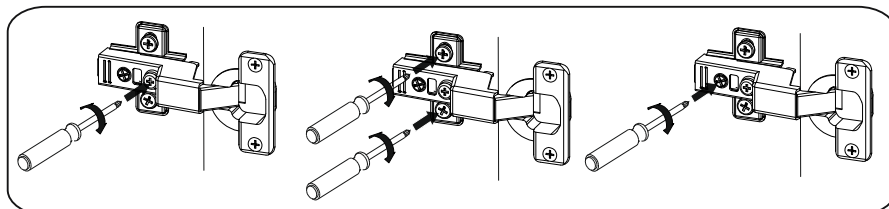
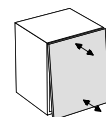
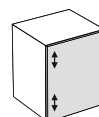
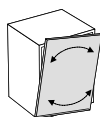
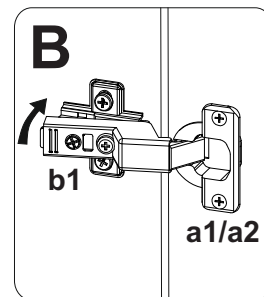
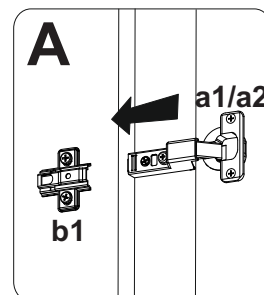
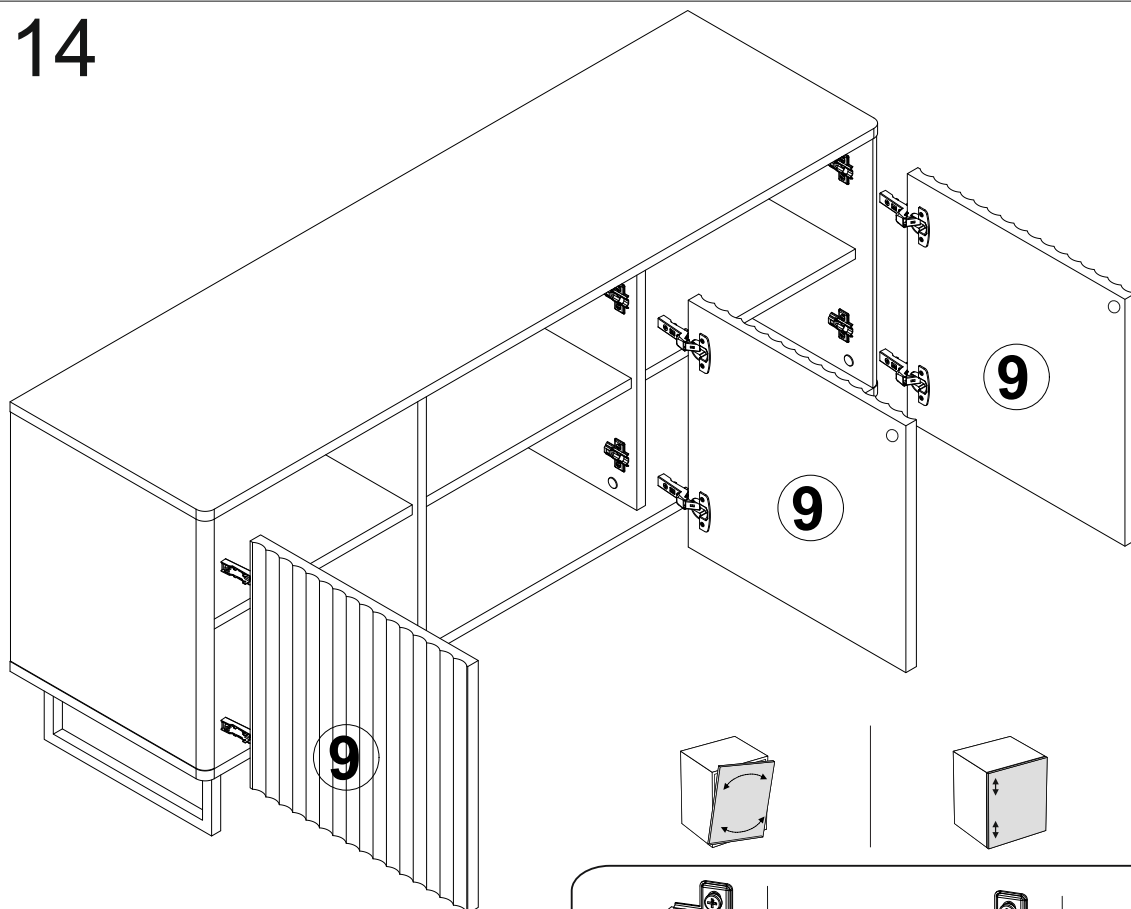

14



15

		$\varnothing 3 \times 20 \text{mm}$
n101\L	x1n101\R	x1p1
		x2

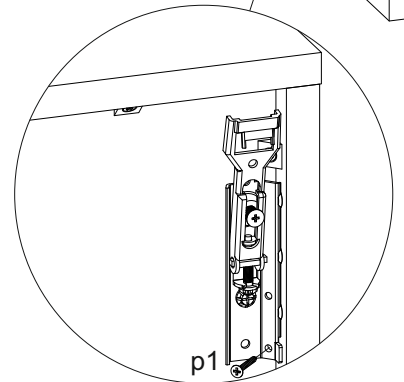
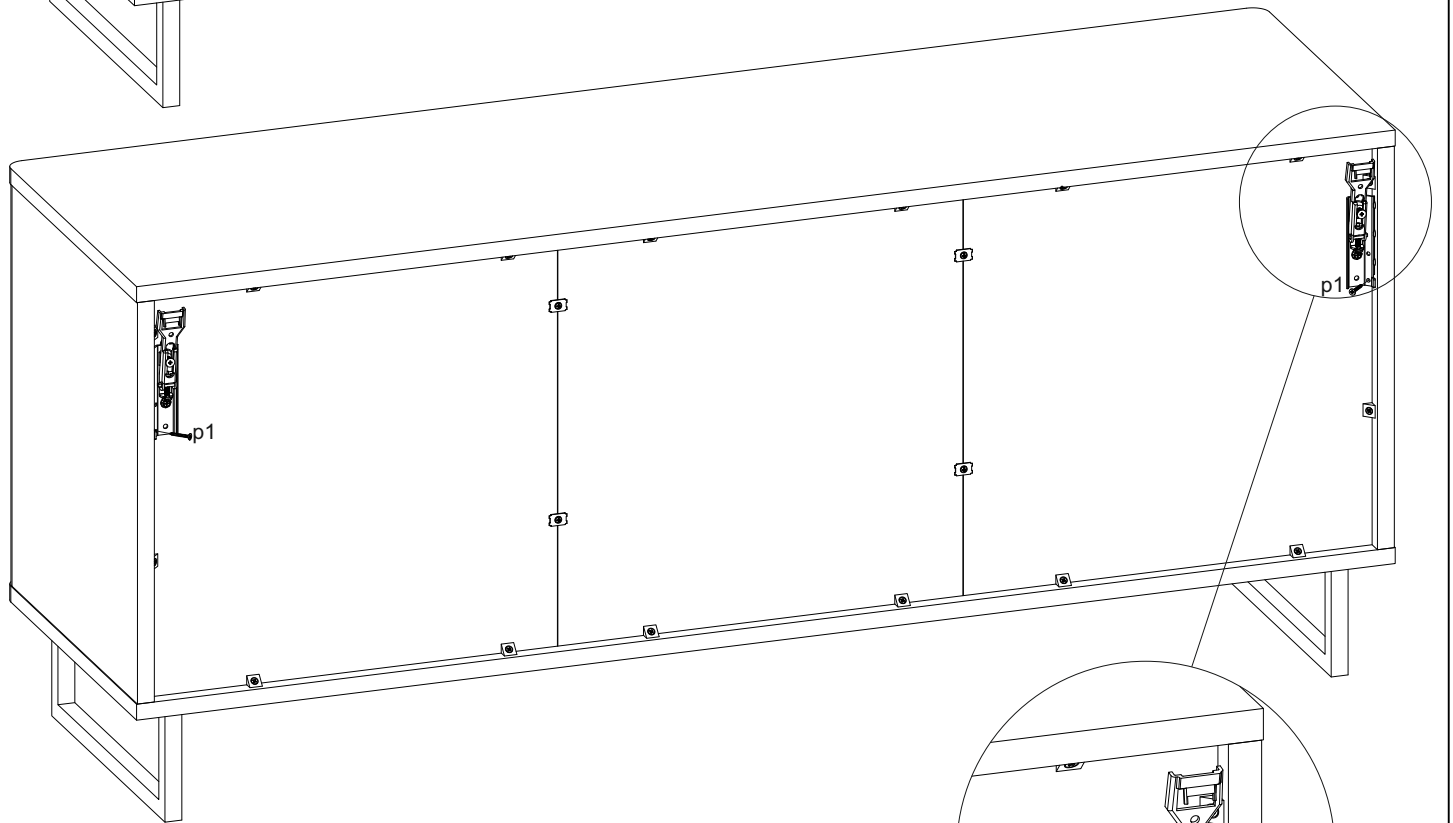
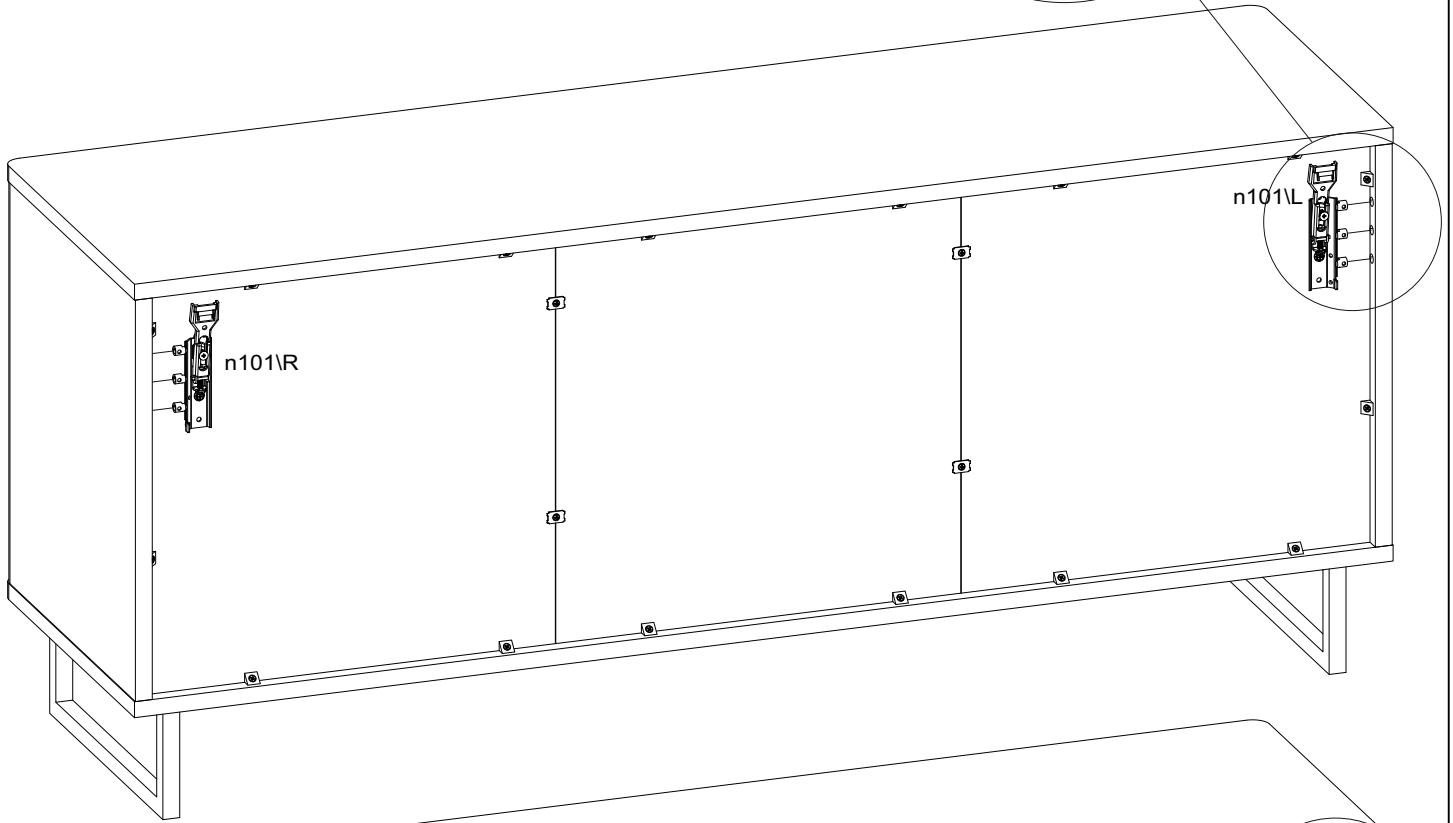
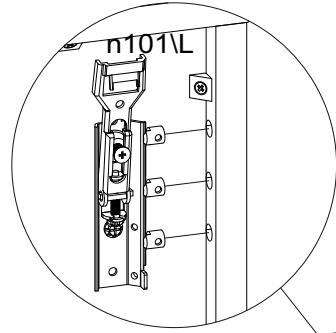

15

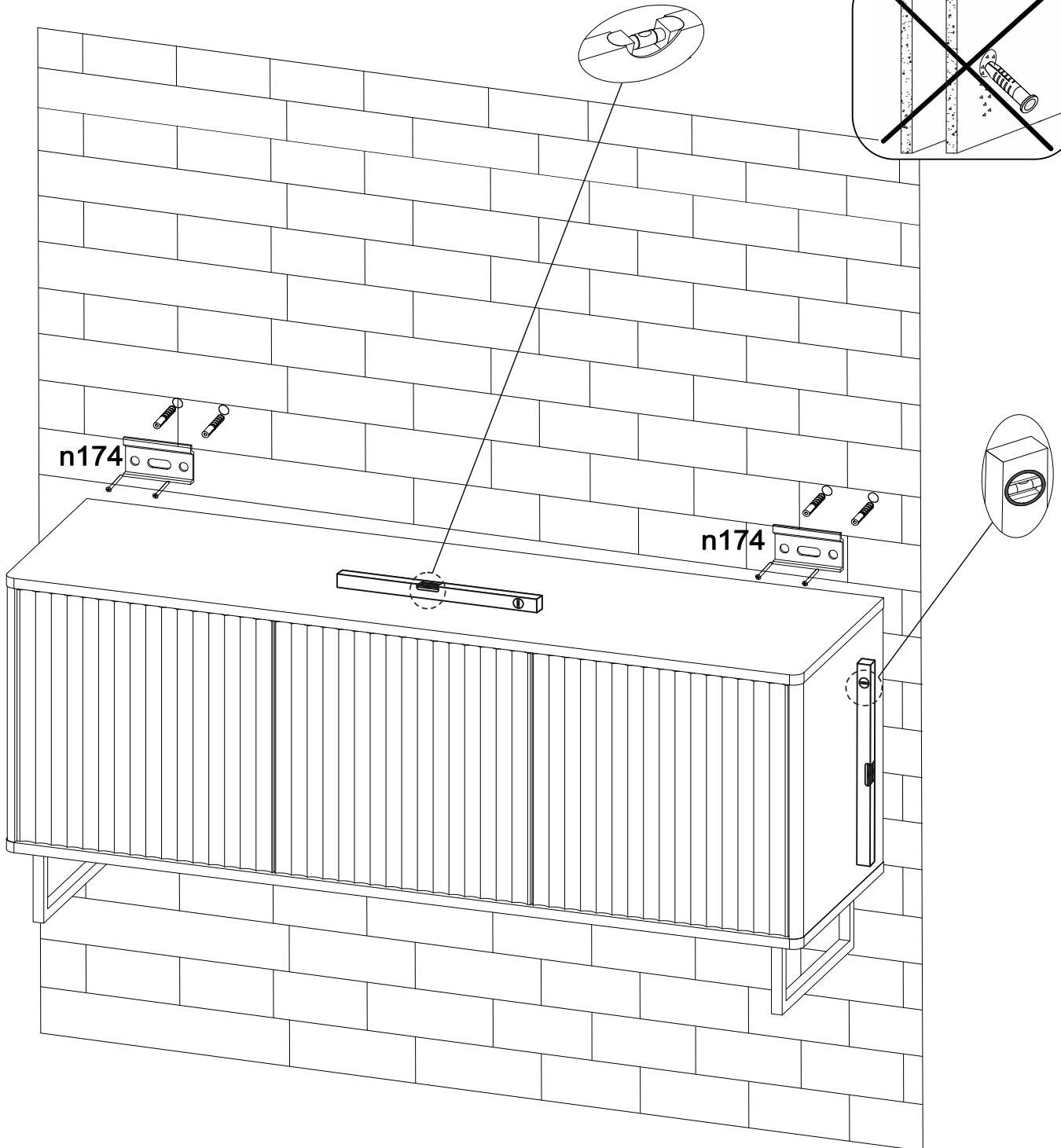
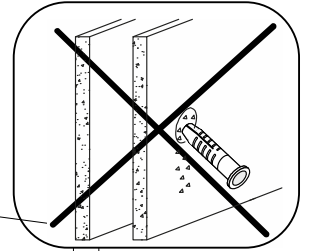
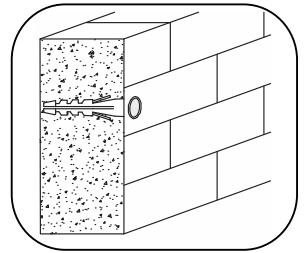
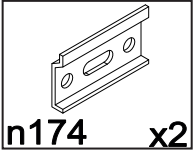

ЧУП «СЕНИРА»

Беларусь, г. Брест, ул. Успенская, 2
т/ф 8 0162 36 46 07 www.senira.by