

**(RU)** Инструкция по сборке

**(GB)** Assembly instructions

**(D)** Montageanleitung

**(FR)** Notice de montage

**(IT)** Istruzioni di montaggio

**(NL)** Handleiding voor de montage

**(CZ)** Montážní návod

**(PL)** Instrukcja montażu

**(SK)** Návod na montáž

**(HU)** Montaj talimati







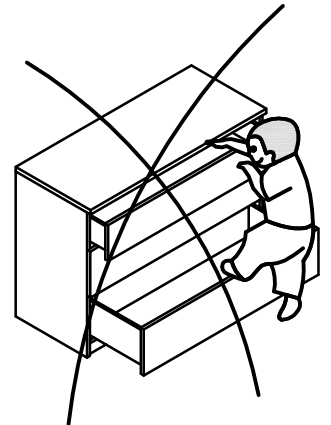
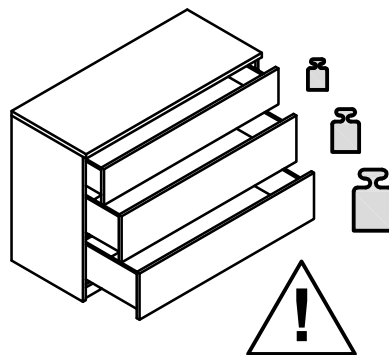
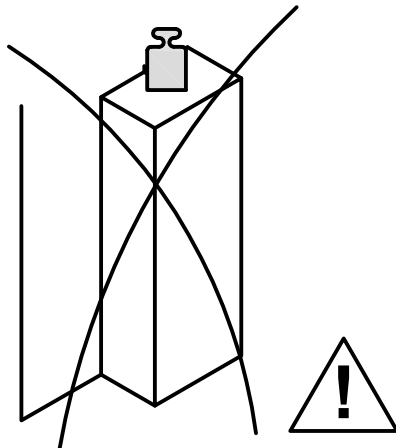
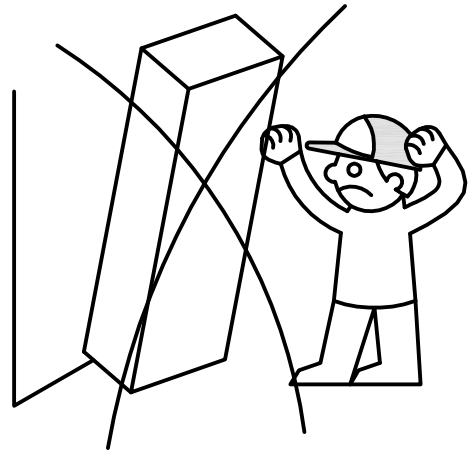
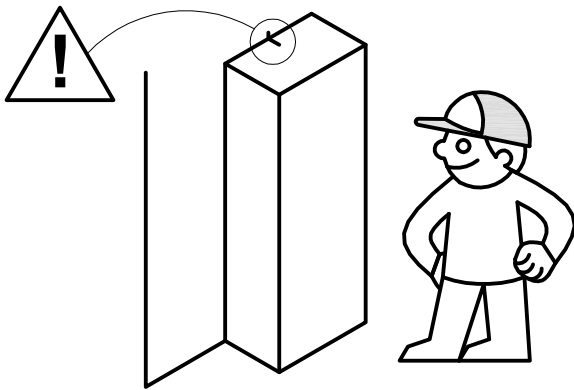
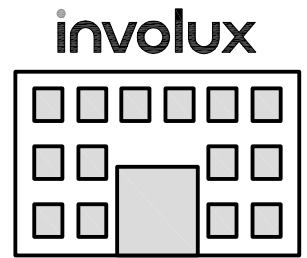
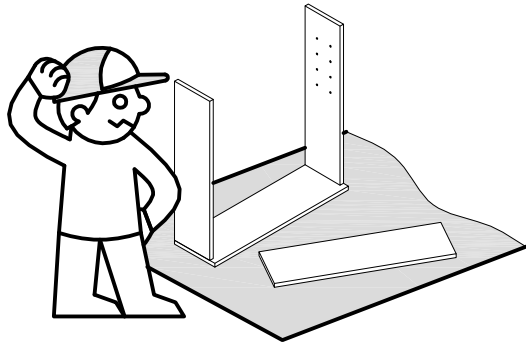
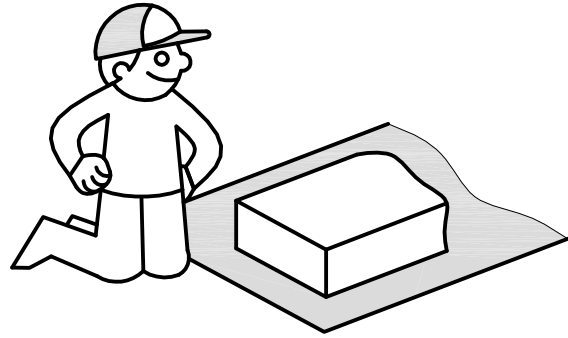
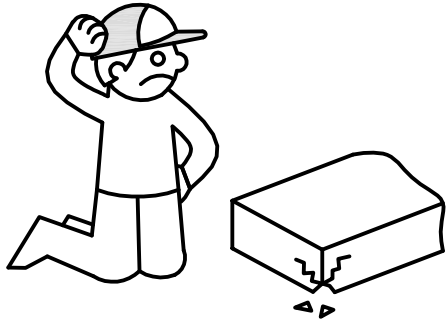
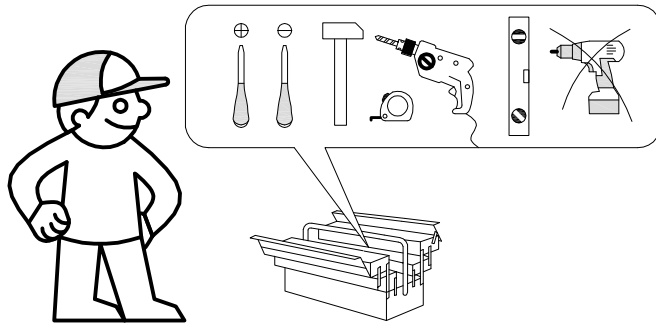

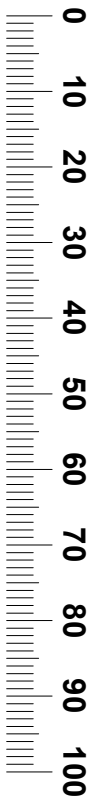

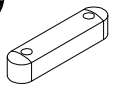

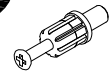

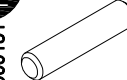

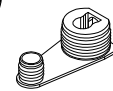
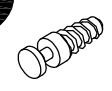

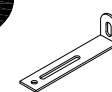

**(RO)** Instrukțiuni de montaj

**(TR)** Szerelési útmutató

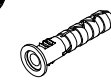
<b>RU</b>	Чтобы предотвратить опрокидывание, <b>ВСЕГДА</b> крепите мебель к стене! Входящие в комплект поставки материалы для крепления на стене (дюбели и шурупы) предназначены только для прочных бетонных стен. Для других типов стен используйте специальные дюбели и шурупы. При необходимости обратитесь за помощью в специализированный магазин .
<b>GB</b>	The enclosed wall mounting materials (dowels and screws) are only suitable for solid masonry (e.g. concrete or brick walls). Special dowels and other screws may be necessary for other wall constructions. If necessary, please consult a qualified professional.
<b>D</b>	Das beidseitig angebrachte Wandbefestigungsmaterial (Dübel und Schrauben) eignet sich nur für festes Mauerwerk (z.B. Beton oder Ziegelwände). Für andere Wandaufbauten sind eventuell Spezialdübel und andere Schrauben notwendig. Ziehen Sie gegebenenfalls eine Fachkraft zurate.
<b>FR</b>	Le matériel de fixation murale fourni (chevilles et vis) convient uniquement à des murs solides (p. ex. murs en béton ou en briques). Pour les autres constructions de murs, il faut éventuellement des chevilles spéciales et d'autres vis. Faites-vous conseiller par un spécialiste.
<b>IT</b>	I materiali di fissaggio allegati (tasselli e viti) sono adatti solo ai muri compatti (ad es. di calcestruzzo o mattoni). Per altri tipi di pareti è probabile che occorrono tasselli speciali e altre tipologie di viti. Richiedere eventualmente il consiglio di un esperto.
<b>NL</b>	Het bijgeleverde bevestigingsmateriaal (pluggen en schroeven) is geschikt voor vaste muren (bijv. betonnen of bakstenen muren). Voor andere muurconstructies zijn eventueel speciale pluggen en andere schroeven noodzakelijk. Consulteer eventueel een vakman.
<b>CZ</b>	Přiloženy materiál pro montáž na stěnu (hmoždinky a šrouby) je vhodný jen pro pevné zdivo (např. betonové nebo cihlové stěny). Pro jiné skladby stěn budou případně nutné speciální hmoždinky a jiné šrouby. Poradte s odborníkem.
<b>PL</b>	Żalączony zestaw montażowy do zamocowania artykułu do ściany (kołki, wkręty, haki itp.), przeznaczony jest do montażu artykułu na ścianach wykonanych z cegły lub betonu. Przy montażu artykułu na ścianie wykonanej z innych materiałów, należy zastosować odpowiednie do niej zamocowania. W razie wątpliwości prosimy zasięgnąć porady fachowca.
<b>SK</b>	Priložený materiál pre upevnenie na stenu (hmoždinky a skrutky) je vhodný len pre pevné murivo (napr. betónové alebo tehlové steny). Pre iné steny sú potrebné príp. špeciálne hmoždinky a iné skrutky. V prípade potreby sa poradte s odborníkom.
<b>HU</b>	A mellékelt fali rögzítéskészlet (tiplé és csavarok) csak t m tt falazatban (pl. betonfalban, téglafalban) használható. Más fal típusokhoz speciális tiplé és csavarra lesz szükség. Szükség esetén kérje ki egy szakember véleményét.
<b>RO</b>	Materialul furnizat pentru montajul de perete (dibluri și șuruburi) este adecvat numai pentru zidărie solidă (de exemplu pereți din beton sau din cărămidă). Pentru alte structuri de pereți, este posibil să fie necesare dibluri special, precum și alte șuruburi. Dacă este necesar, consultați un specialist.
<b>TR</b>	Teslimat kapsamındaki duvar tipi sabitleme materyali (dübel ve vidalar) sadece beton ve tuğla duvarlar gibi sağlam duvar yapıları için uygundur. Başka duvar yapıları için özel dübeller veya başka vidalar gereklidir. Gerekirse bir uzmandan yardım alın.



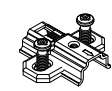
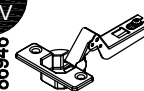

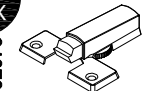
<b>A</b> 000125  <b>x1</b>	<b>B</b> 100640 20x0.5  <b>x39</b>	<b>C</b> 090913 7x32  <b>x46</b>	<b>D</b> 000146 15x12  <b>x46</b>	<b>E</b> 000151 8x35  <b>x16</b>	<b>F</b> 007086 M6  <b>x8</b>
<b>G</b> 208693 M6x16  <b>x8</b>	<b>H</b> 204525  <b>x5</b>	<b>I</b> 092069 M6x12  <b>x5</b>	<b>J</b> 170390  <b>x4</b>	<b>K</b> 000762 3.5x13  <b>x8</b>	<b>L</b> 000769 2.5x20  <b>x2</b>
<b>M</b> 196160  <b>x1</b>	<b>N</b> 000763 3x13  <b>x2</b>	<b>O</b> 155999  <b>x1</b>	<b>P</b> 000764 3.5x16  <b>x2</b>	<b>Q</b> 013859 8x40  <b>x1</b>	<b>R</b> 090185 4.5x45  <b>x1</b>
<b>S</b> 194064  <b>x2</b>	<b>T</b> 002704 M4x20  <b>x2</b>	<b>U</b> 092075  <b>x8</b>	<b>V</b> 186946  <b>x8</b>	<b>W</b> 010942 4x16  <b>x16</b>	<b>X</b> 092076  <b>x2</b>

N	Size/MaB (mm)	Qty	✓	N	Size/MaB (mm)	Qty	✓
1	2122x400x16	1		8	404x354x16	5	
2	2122x400x16	1		9	964x560x16	1	
3	2122x583x16	1		10	852x66x16	1	
4	964x200x16	1		11	2132x486x3	2	
5	2122x400x16	1		12	2132x414x3	1	
6	1020x1020x16	1		13	2048x422x16	2	
7	1020x1020x16	1		14	958	2	
				15	2120	1	

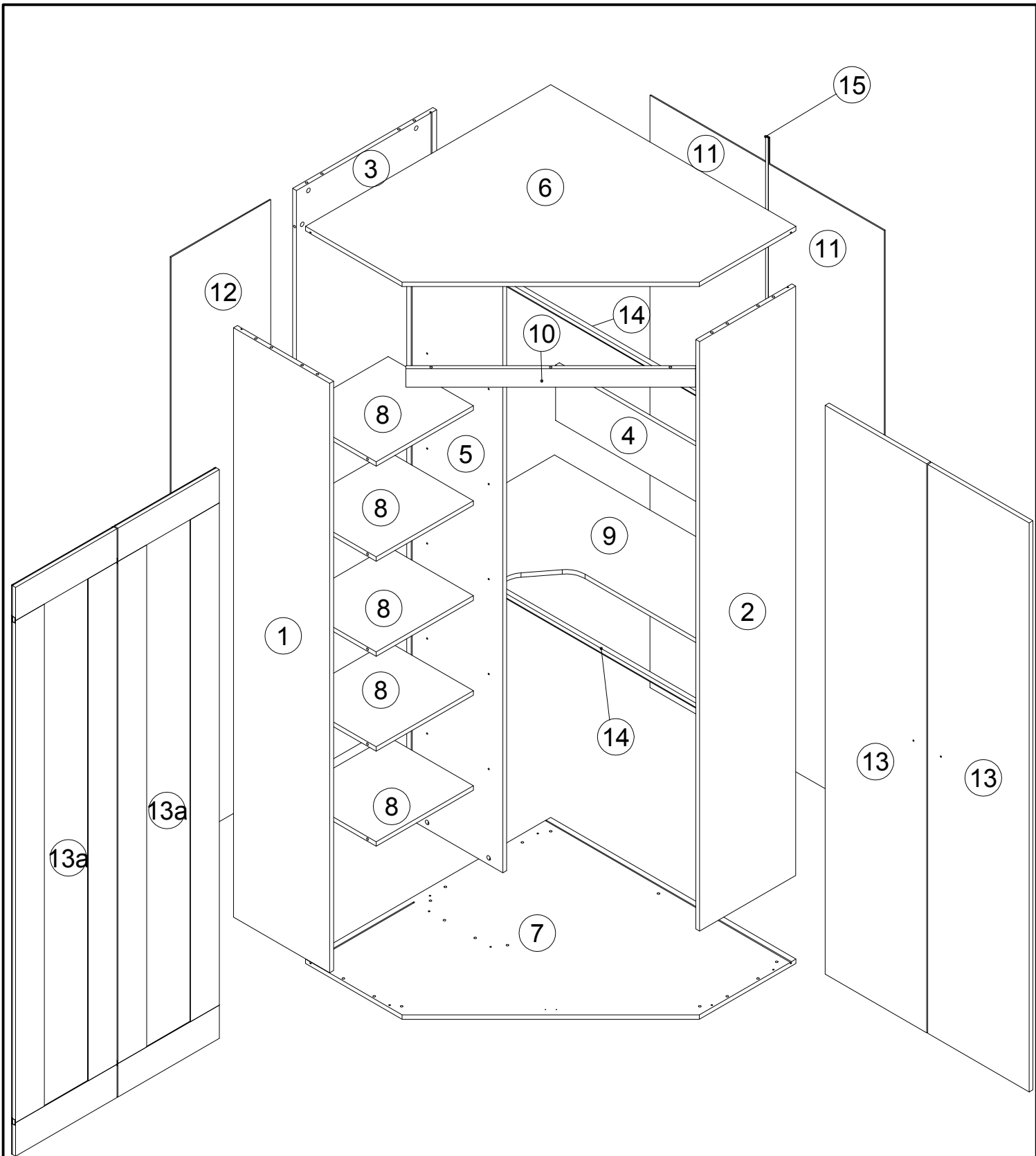

1

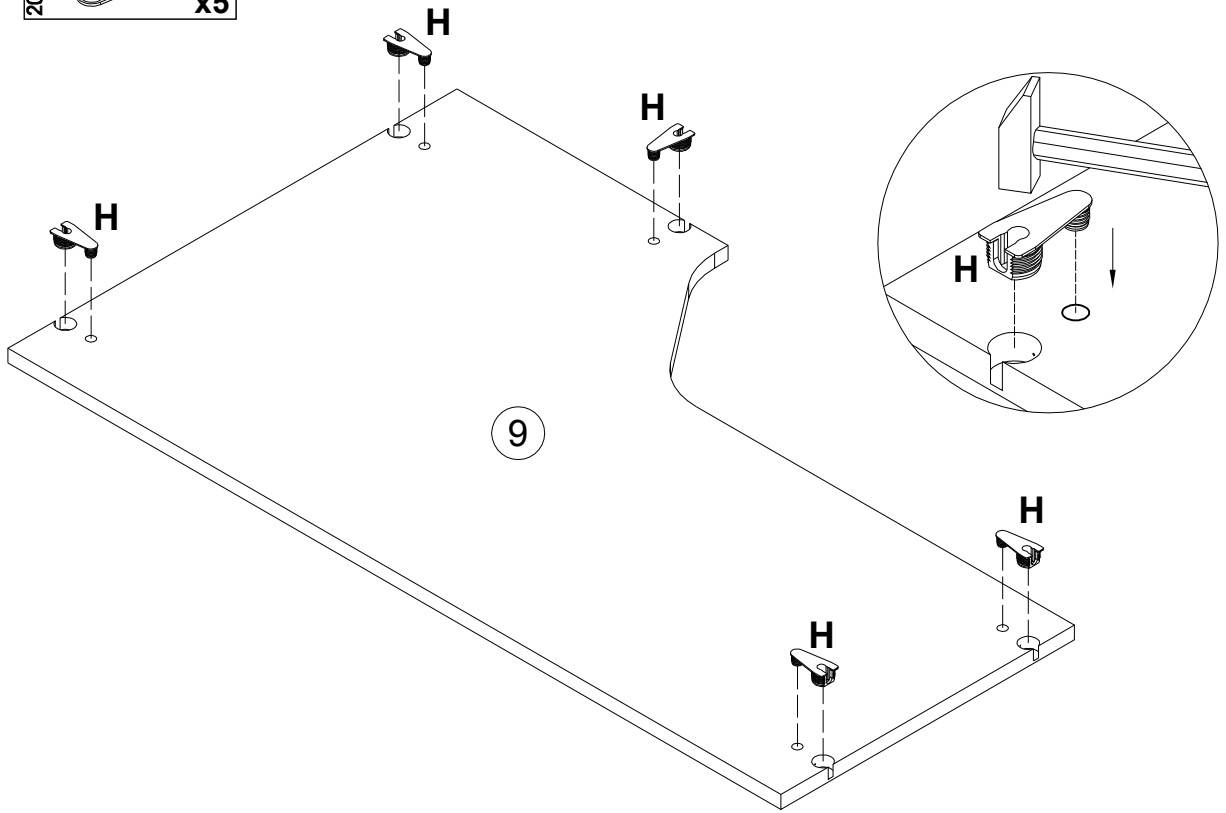
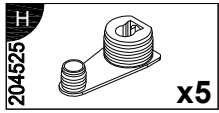

2

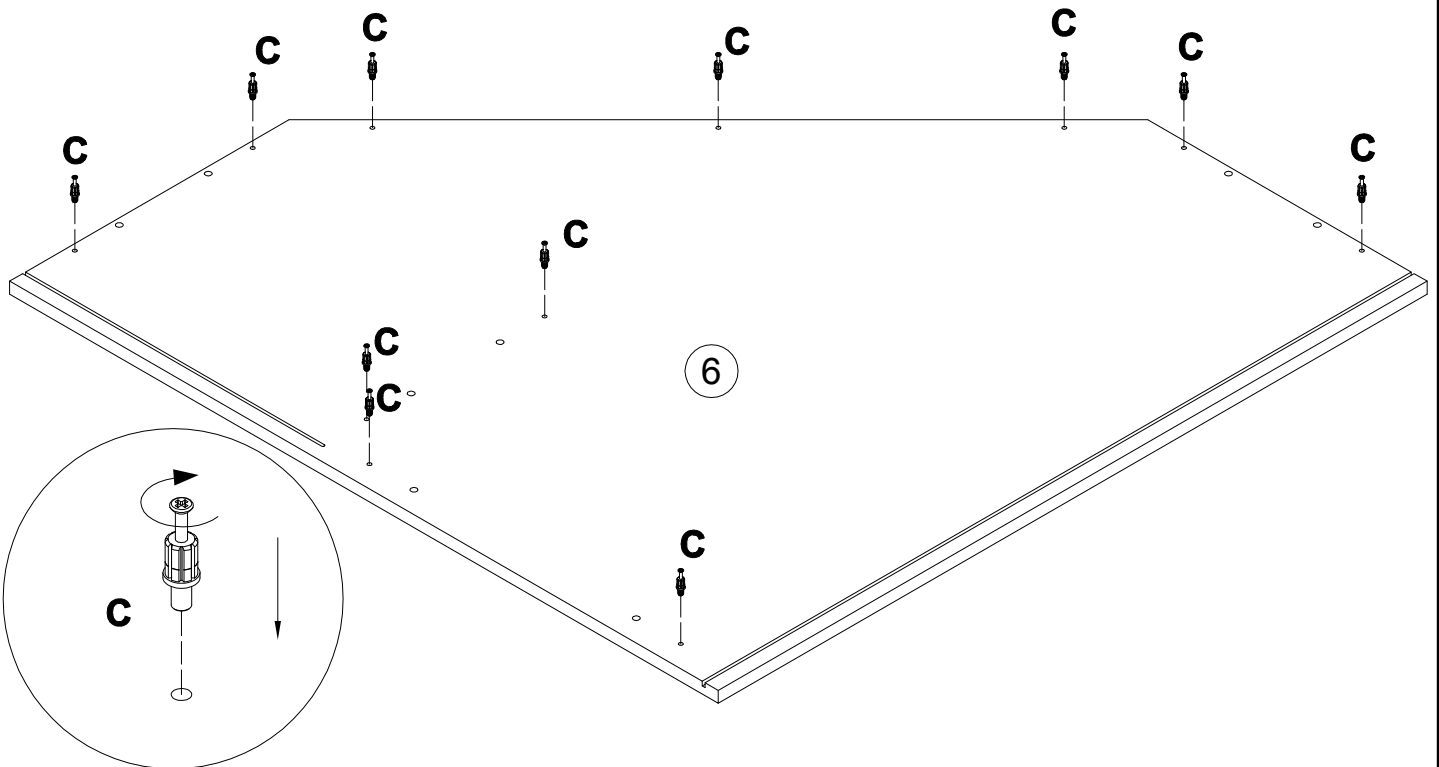
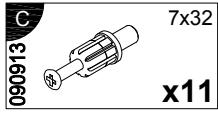

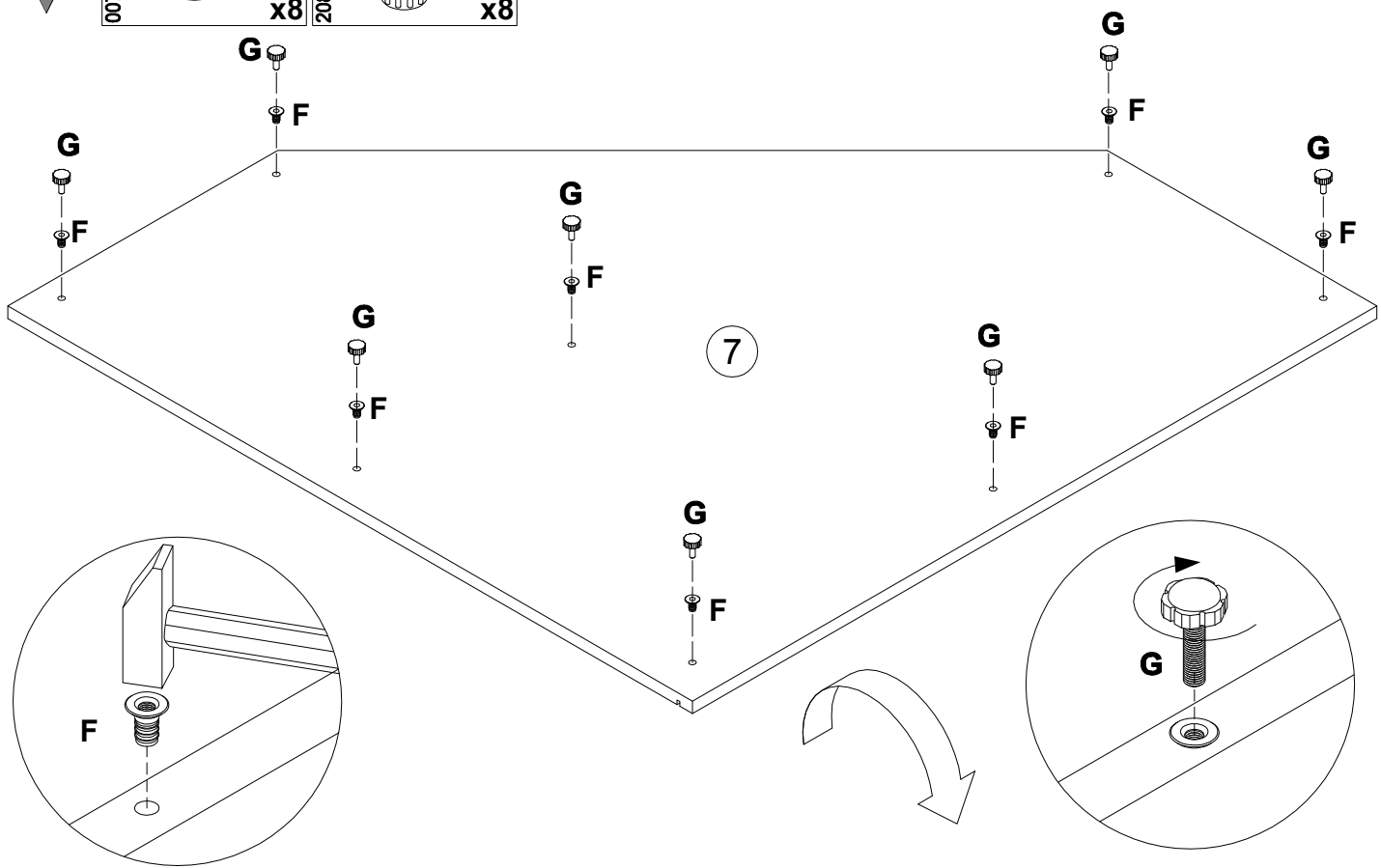
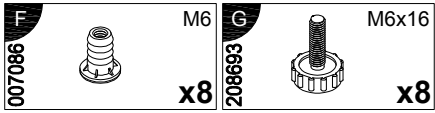

3

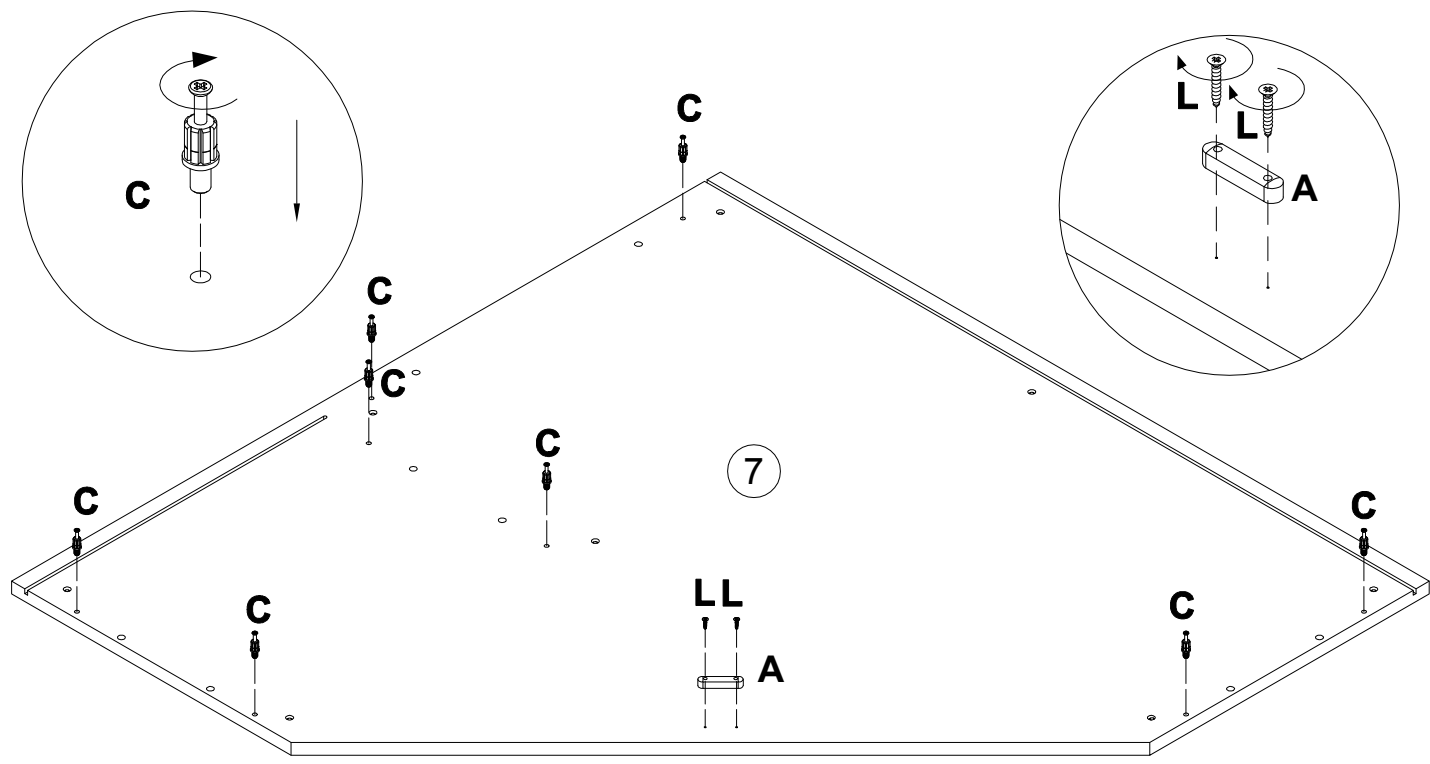
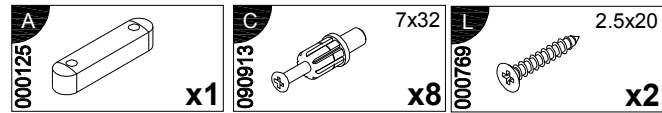

4



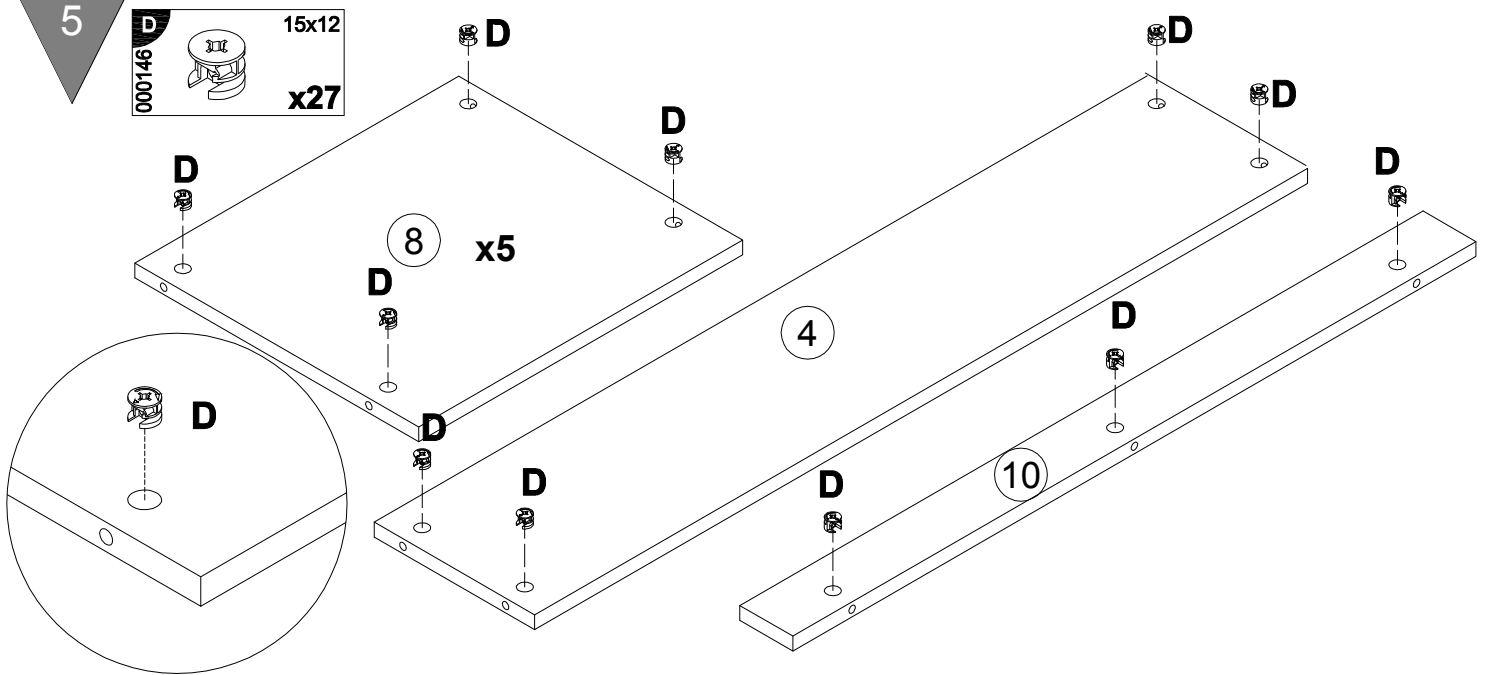

5

 15x12  
 x27



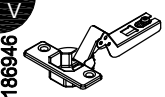

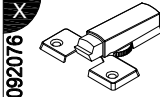
6

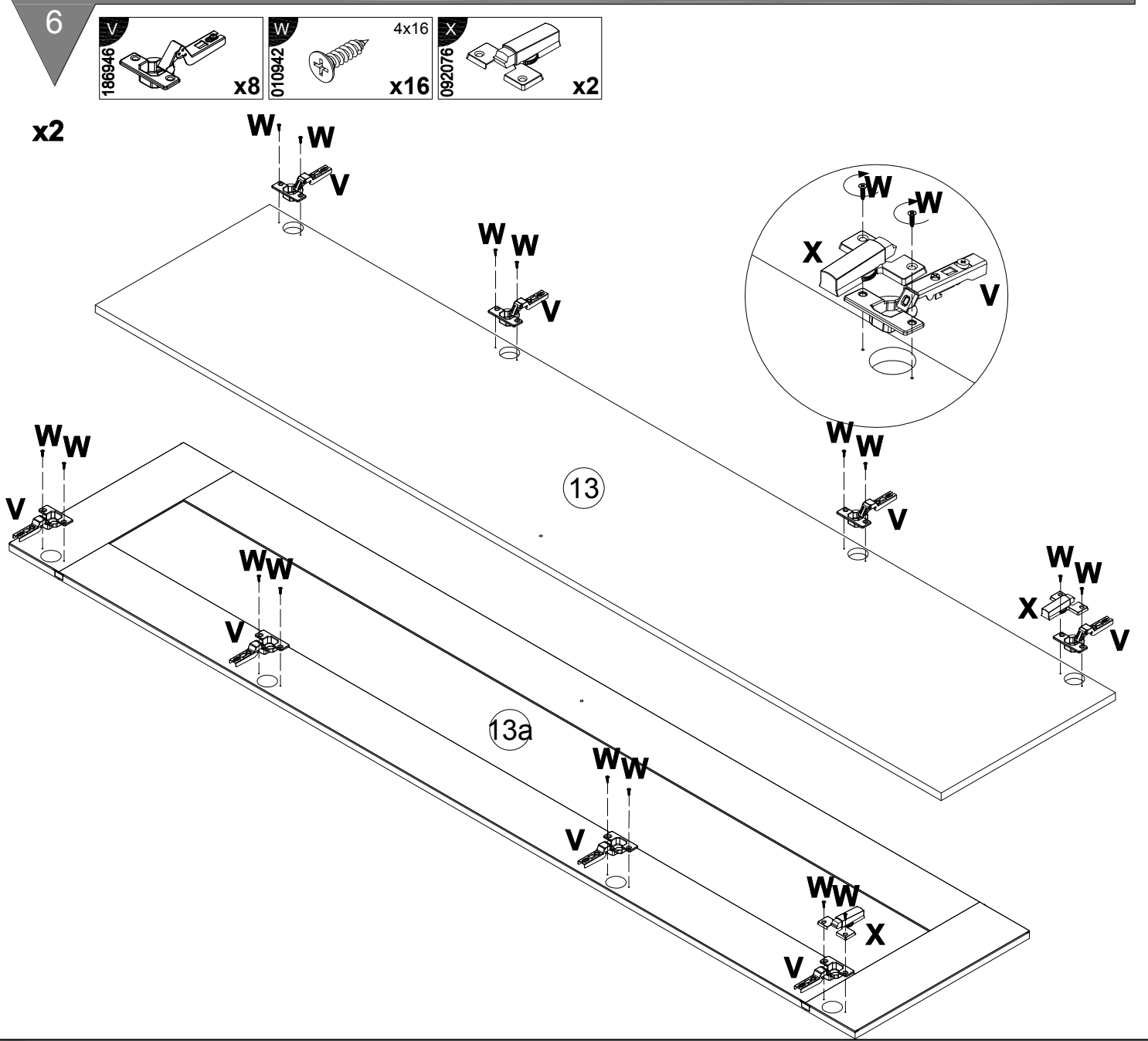
 x8  
 4x16  
 x2





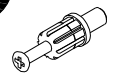

7

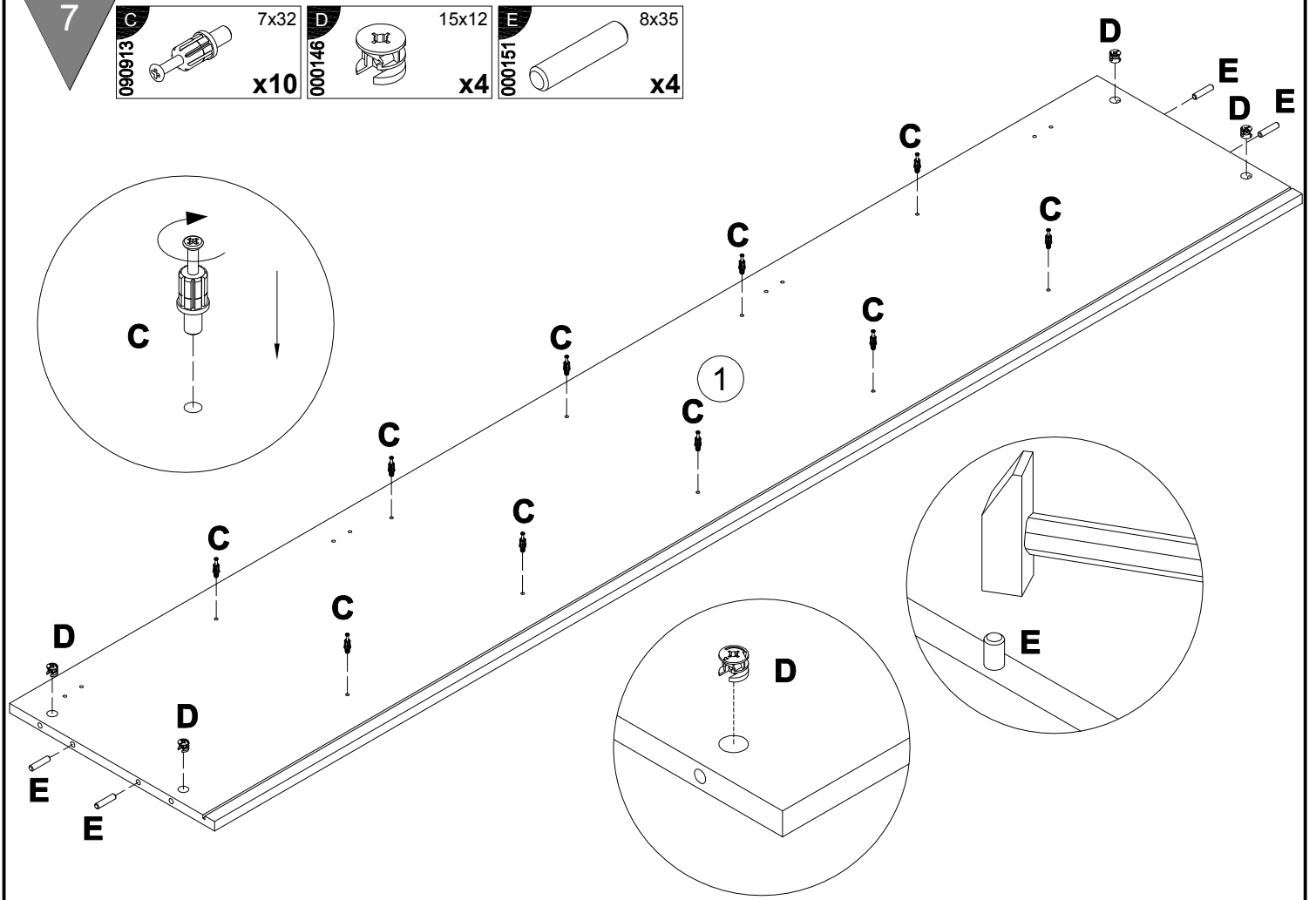
<b>C</b>		7x32	<b>D</b>		15x12	<b>E</b>		8x35
	090913	x10		000146	x4		000151	x4

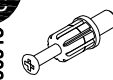

8

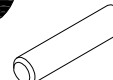
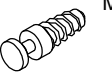
<b>C</b>		7x32	<b>D</b>		15x12	<b>F</b>		8x35	<b>I</b>		M6x12
	090913	x2		000146	x4		000151	x4		092069	x2

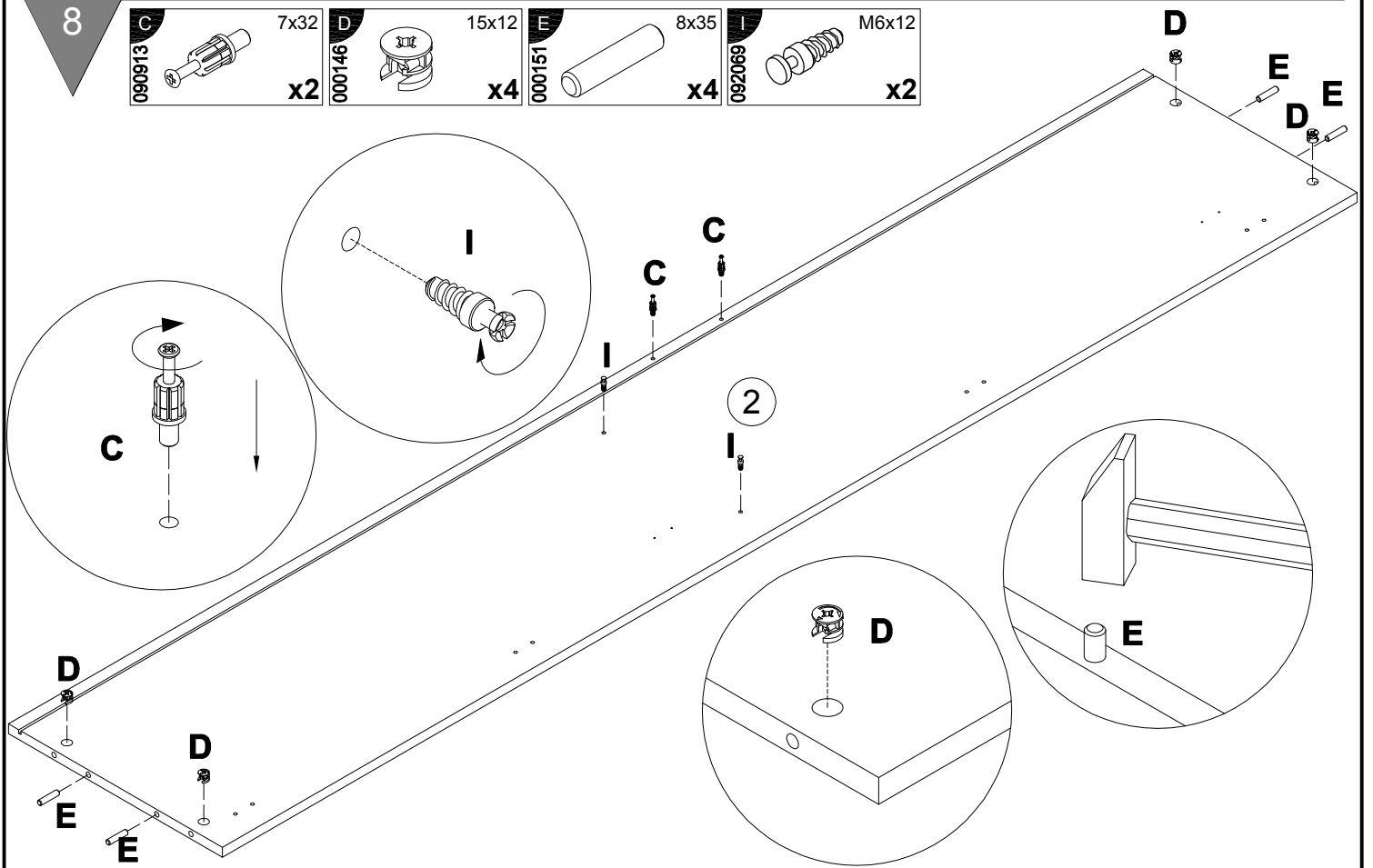

9

170390		x2	000762		x4	092075		x8
--------	--	----	--------	--	----	--------	--	----

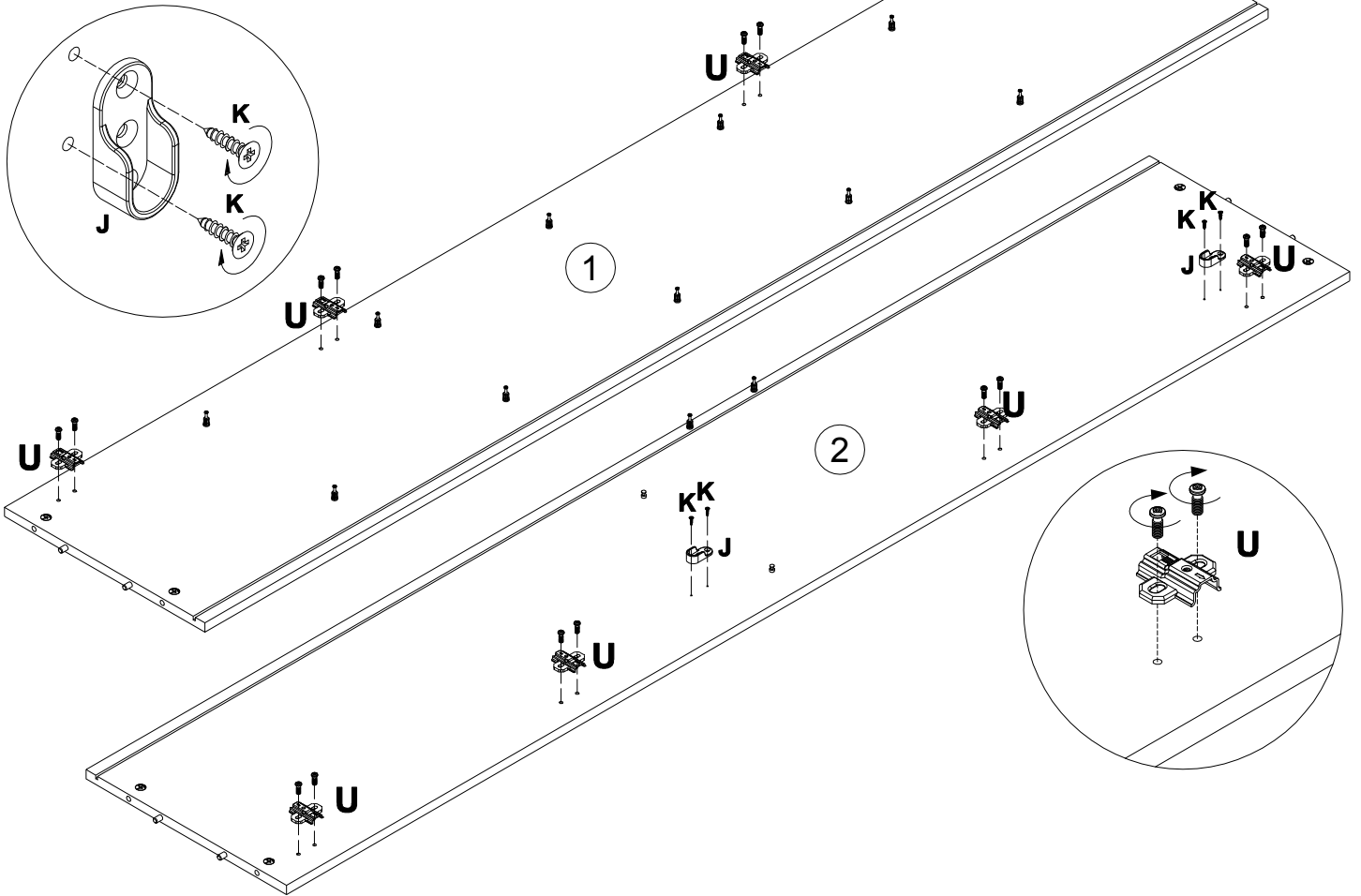

10

090913		x2	000146		x7	000151		x4
--------	--	----	--------	--	----	--------	--	----

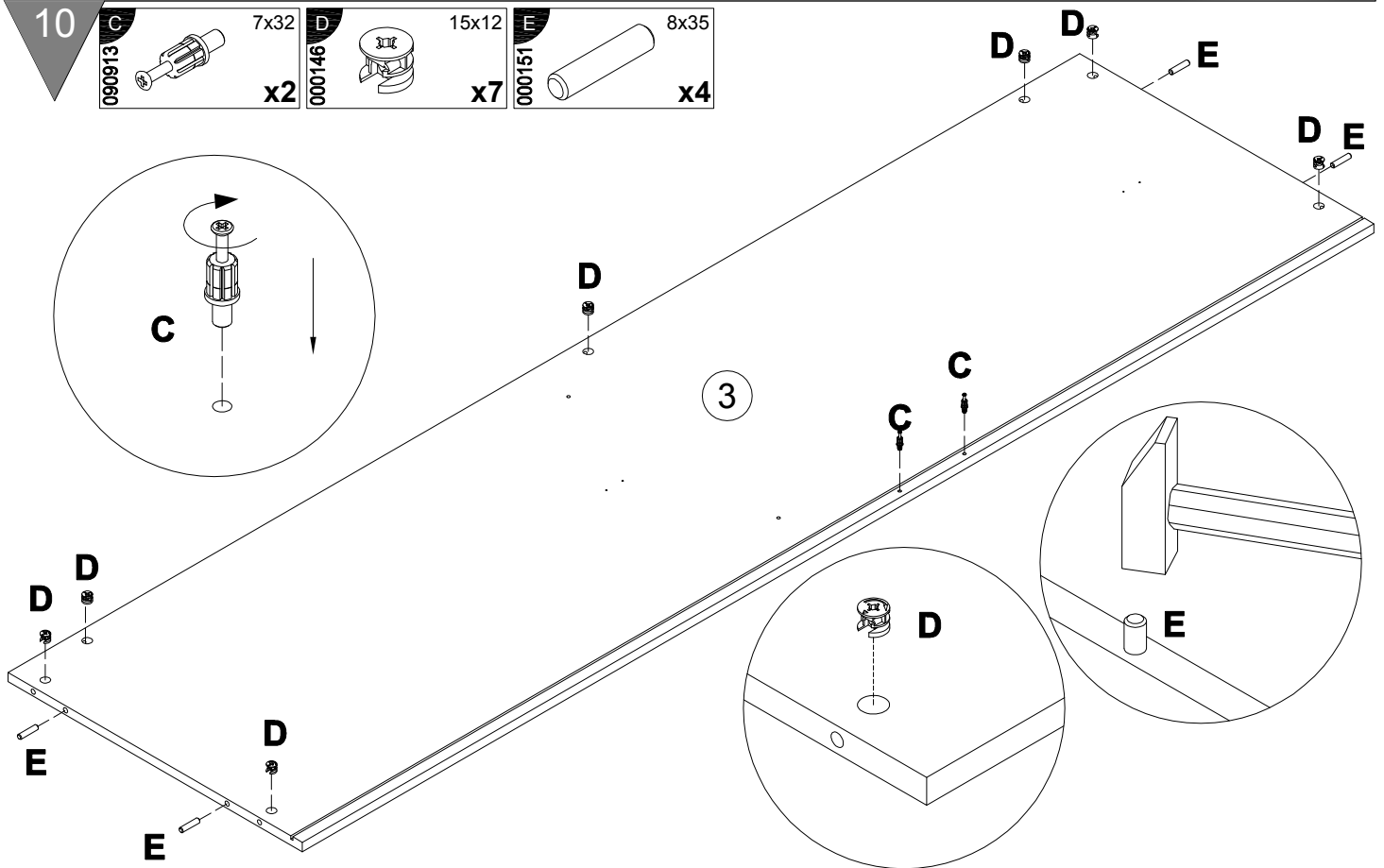

11

092069	M6x12	170390	K	3.5x13
	x2			x4

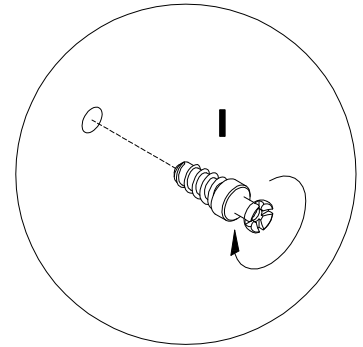
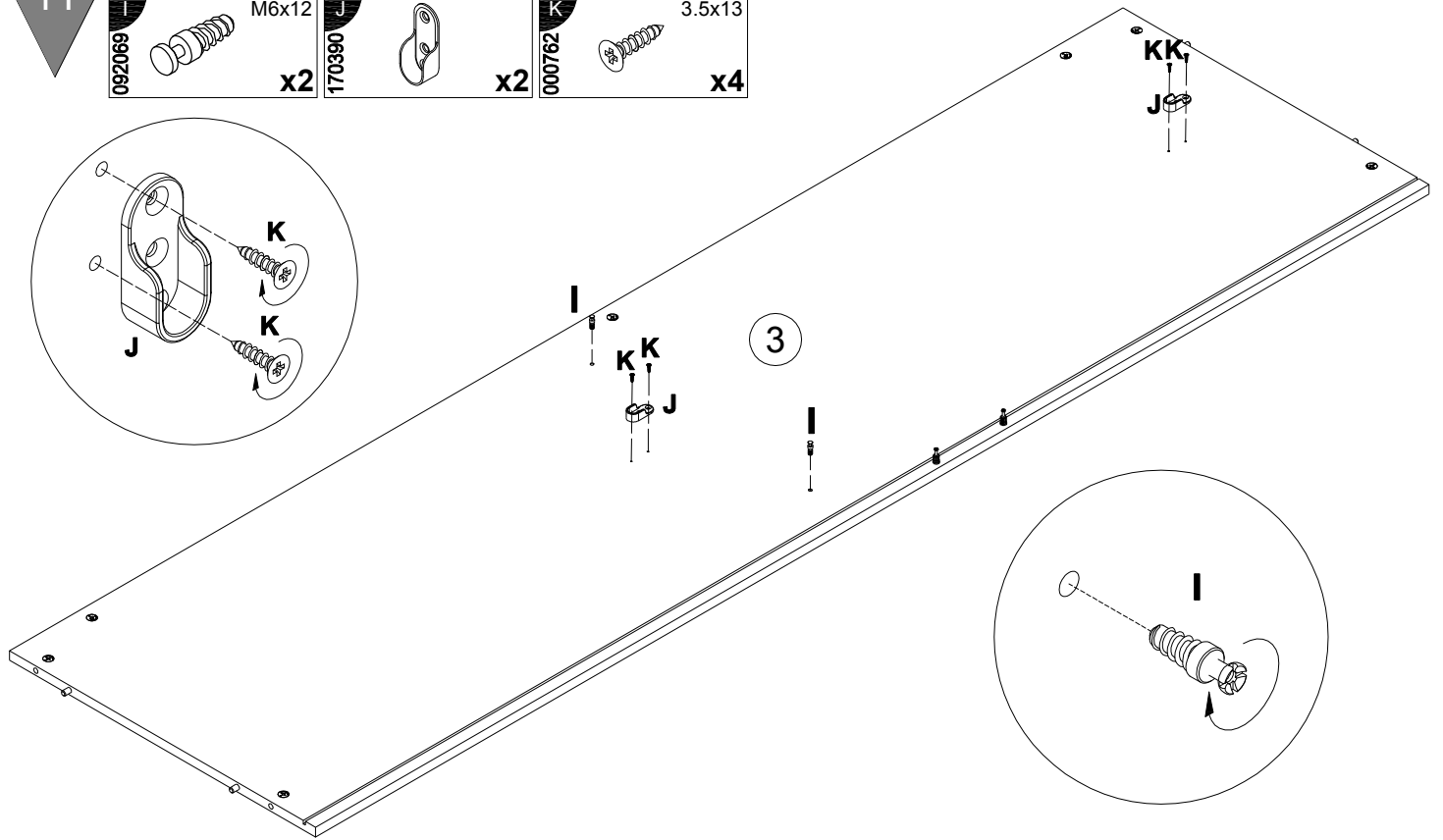
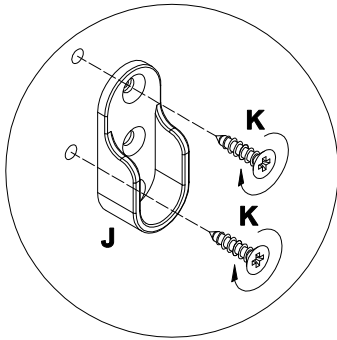

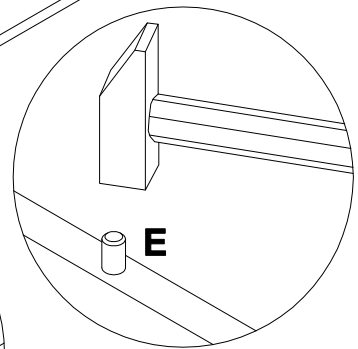
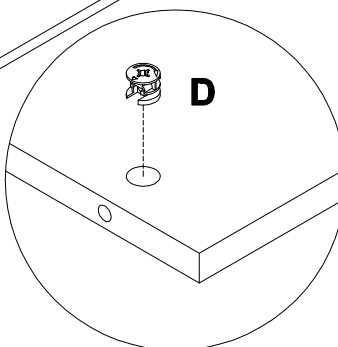
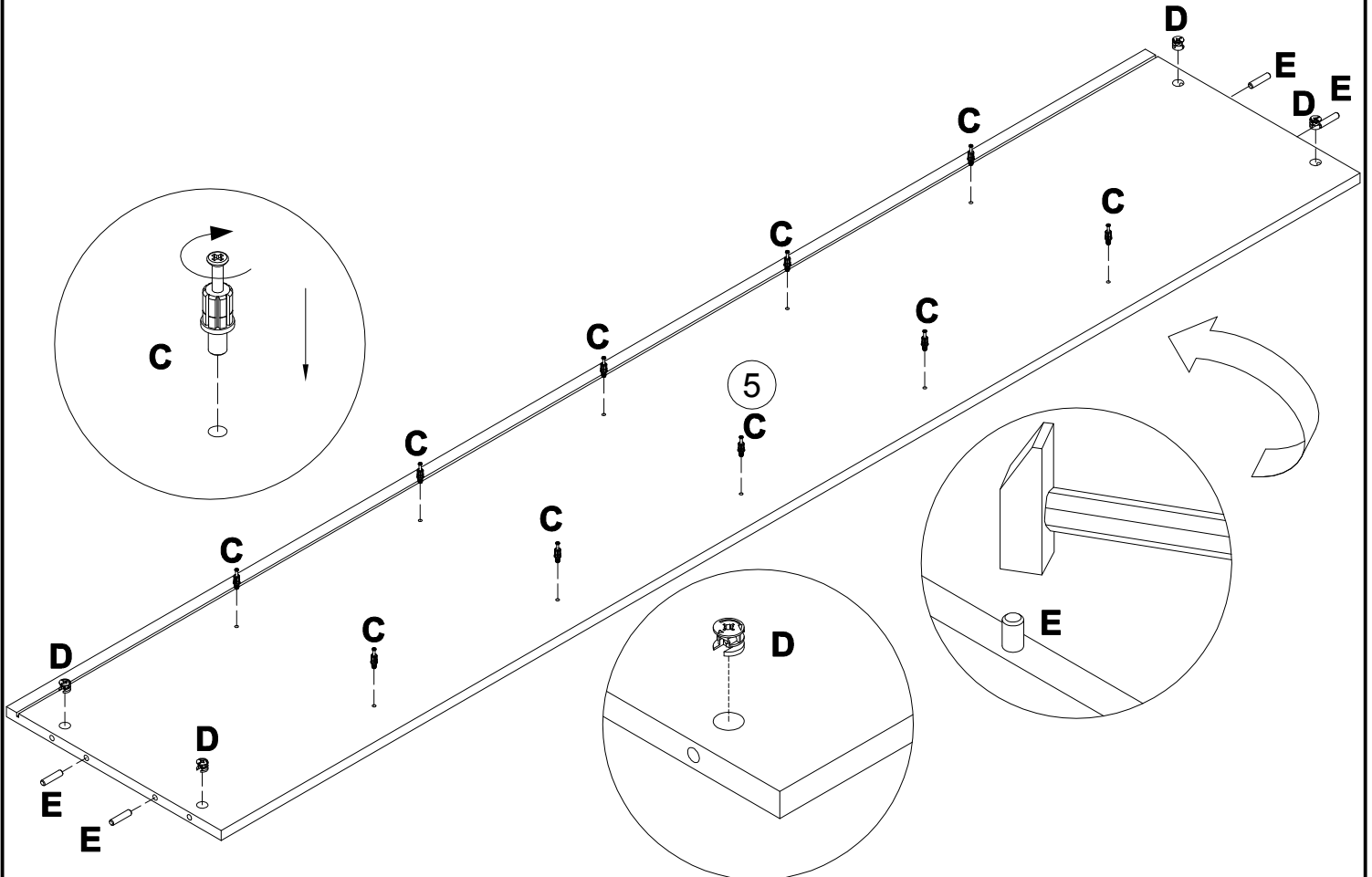
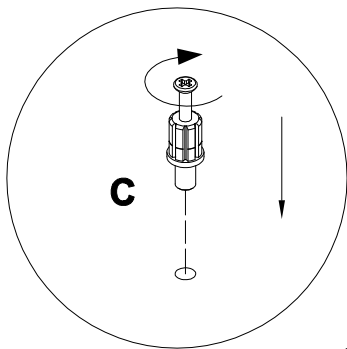

12

090913	7x32	000146	15x12	000151	8x35
	x10		x4		x4

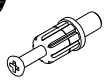

13

<b>C</b> 090913		7x32	<b>I</b> 092069		M6x12
		<b>x3</b>			<b>x1</b>

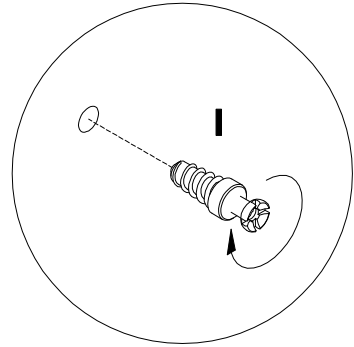
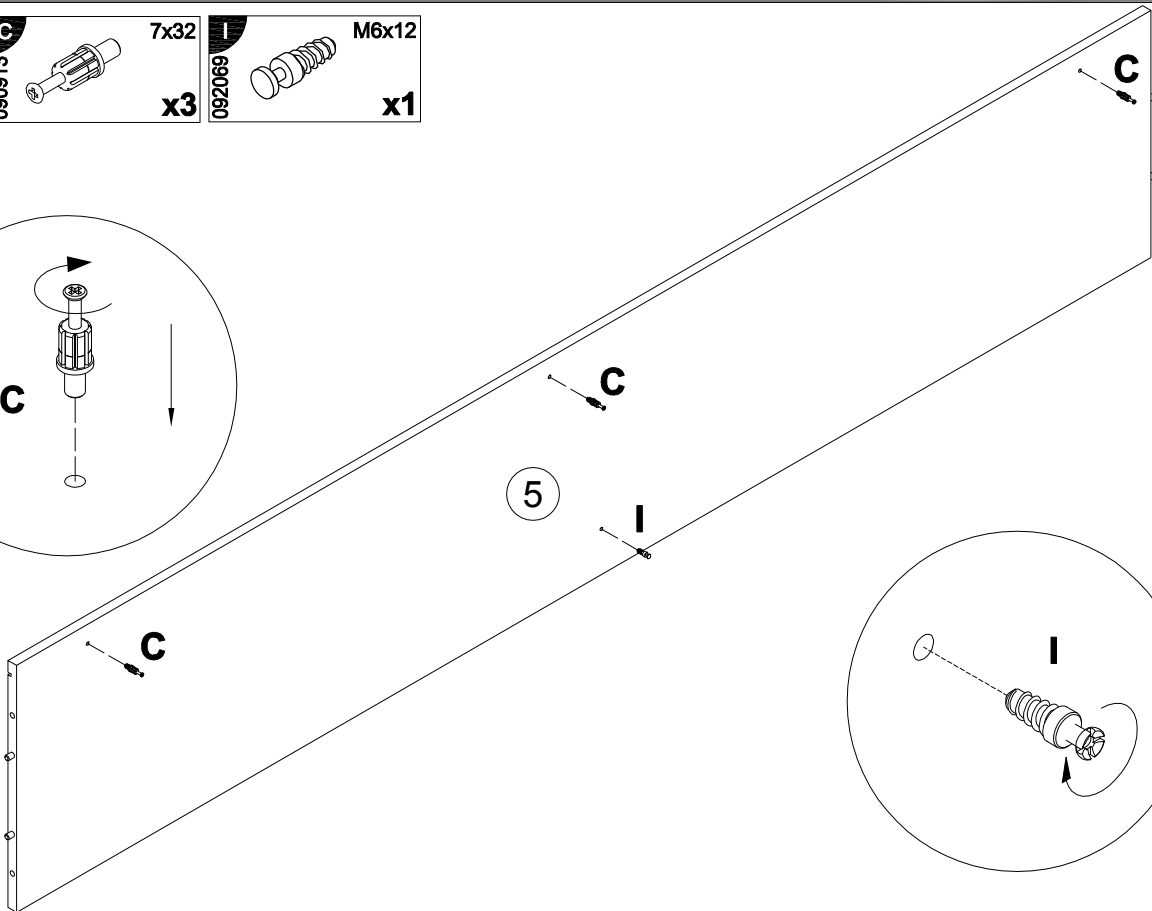
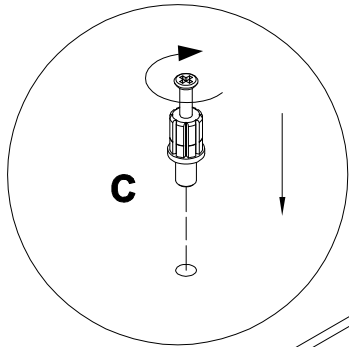

14

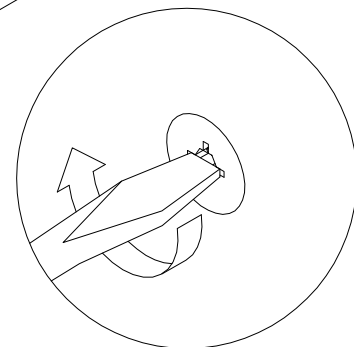
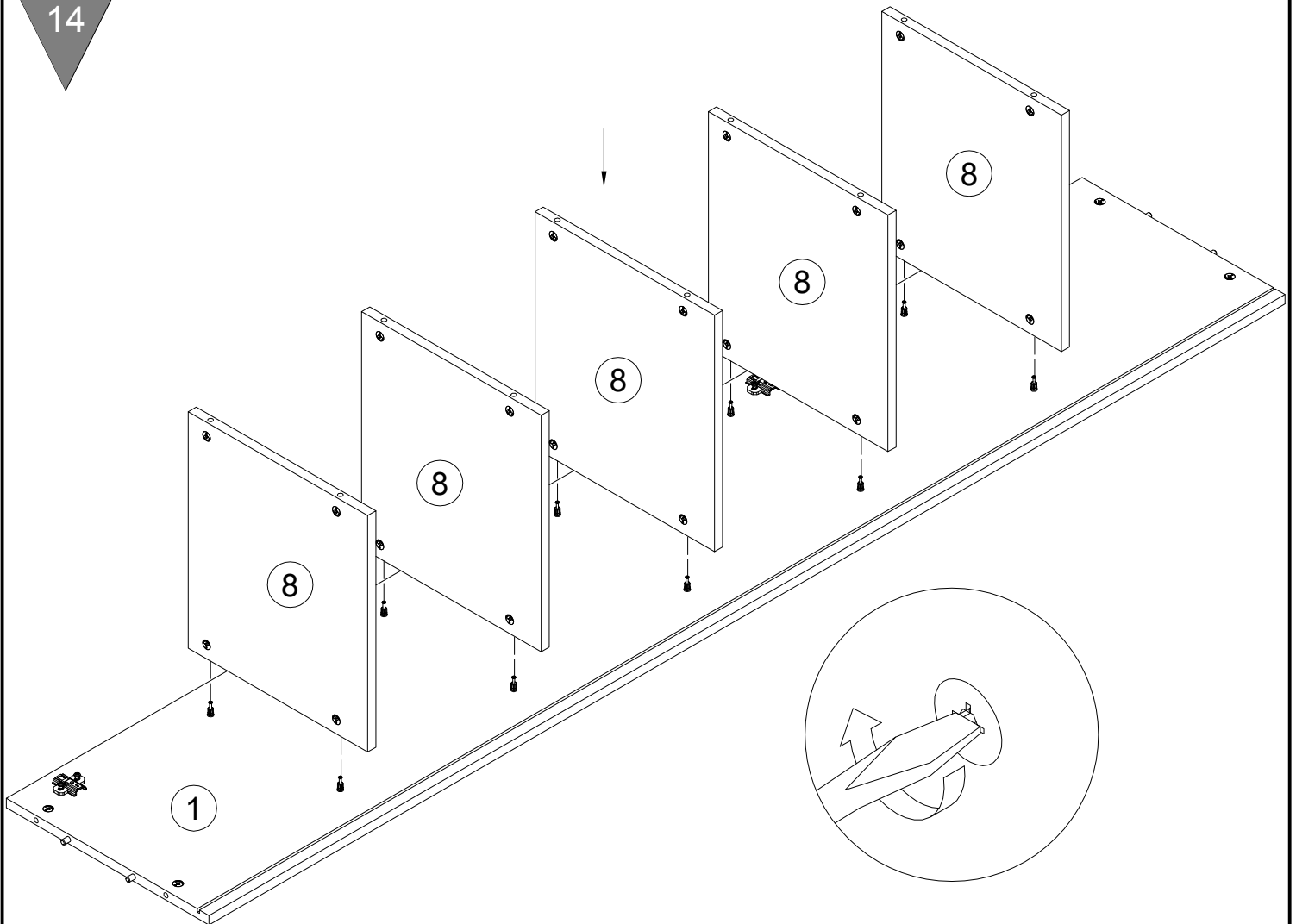

15

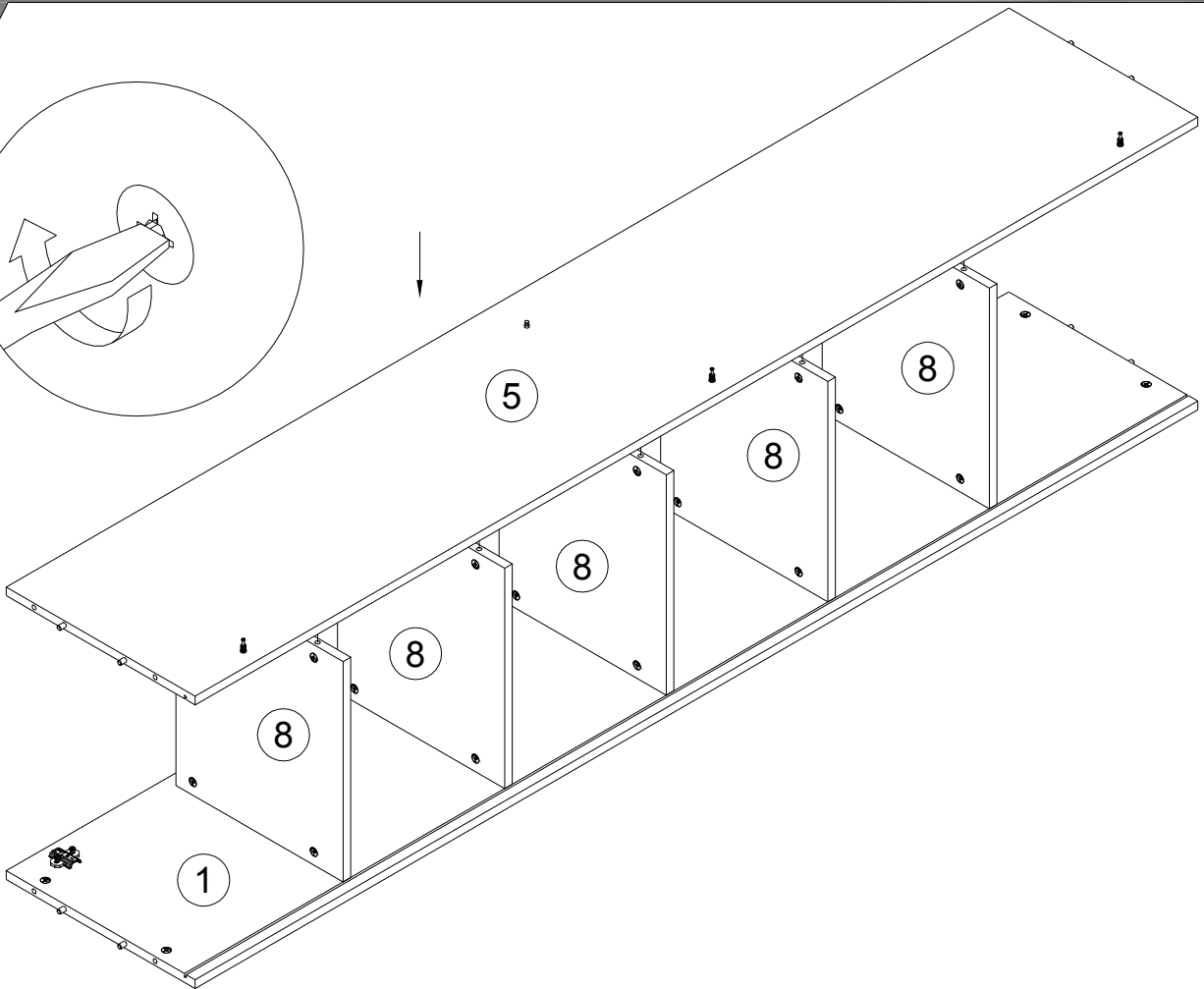
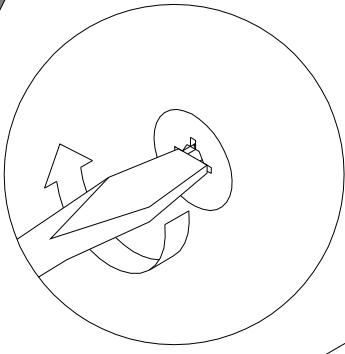

16

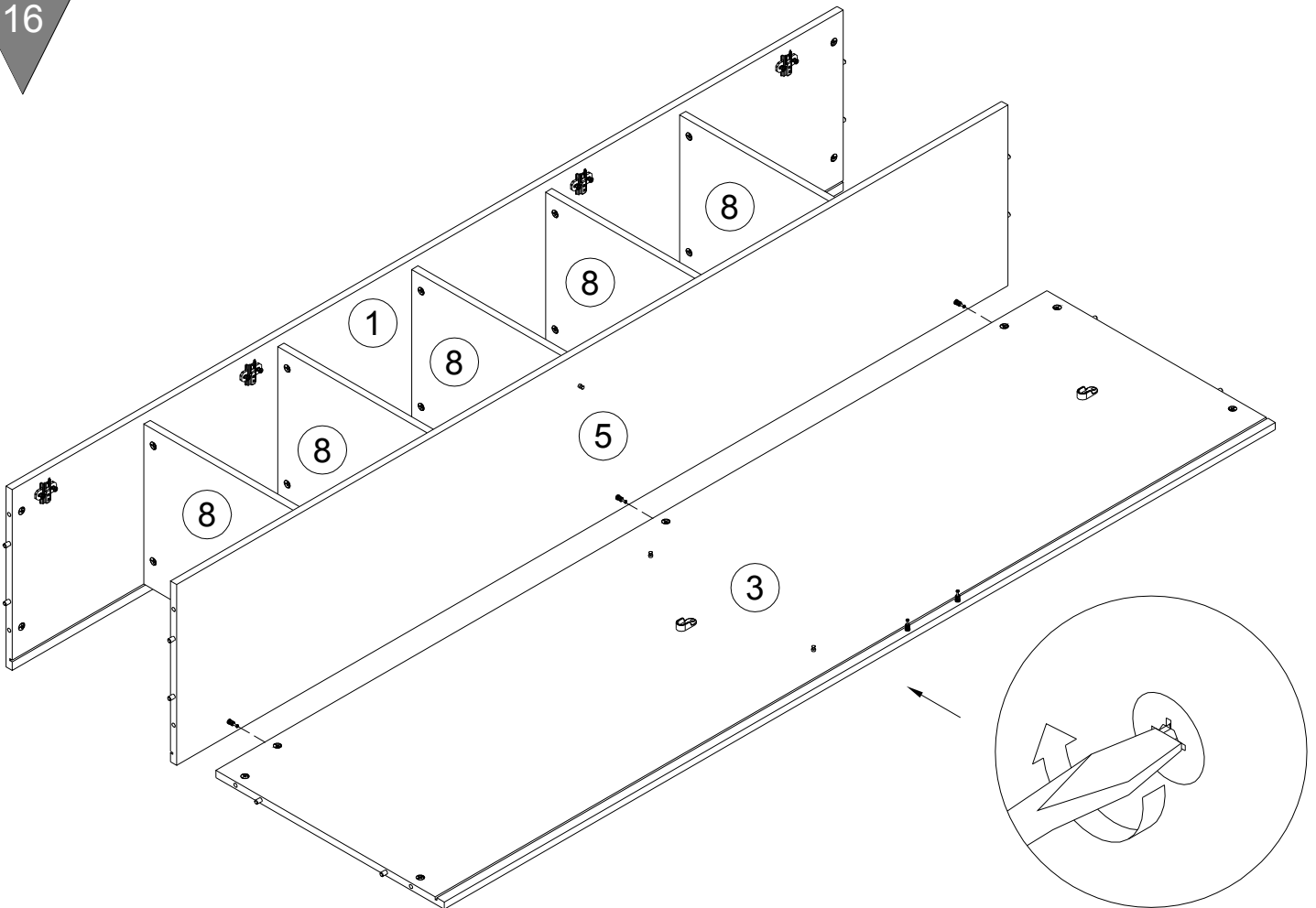

17

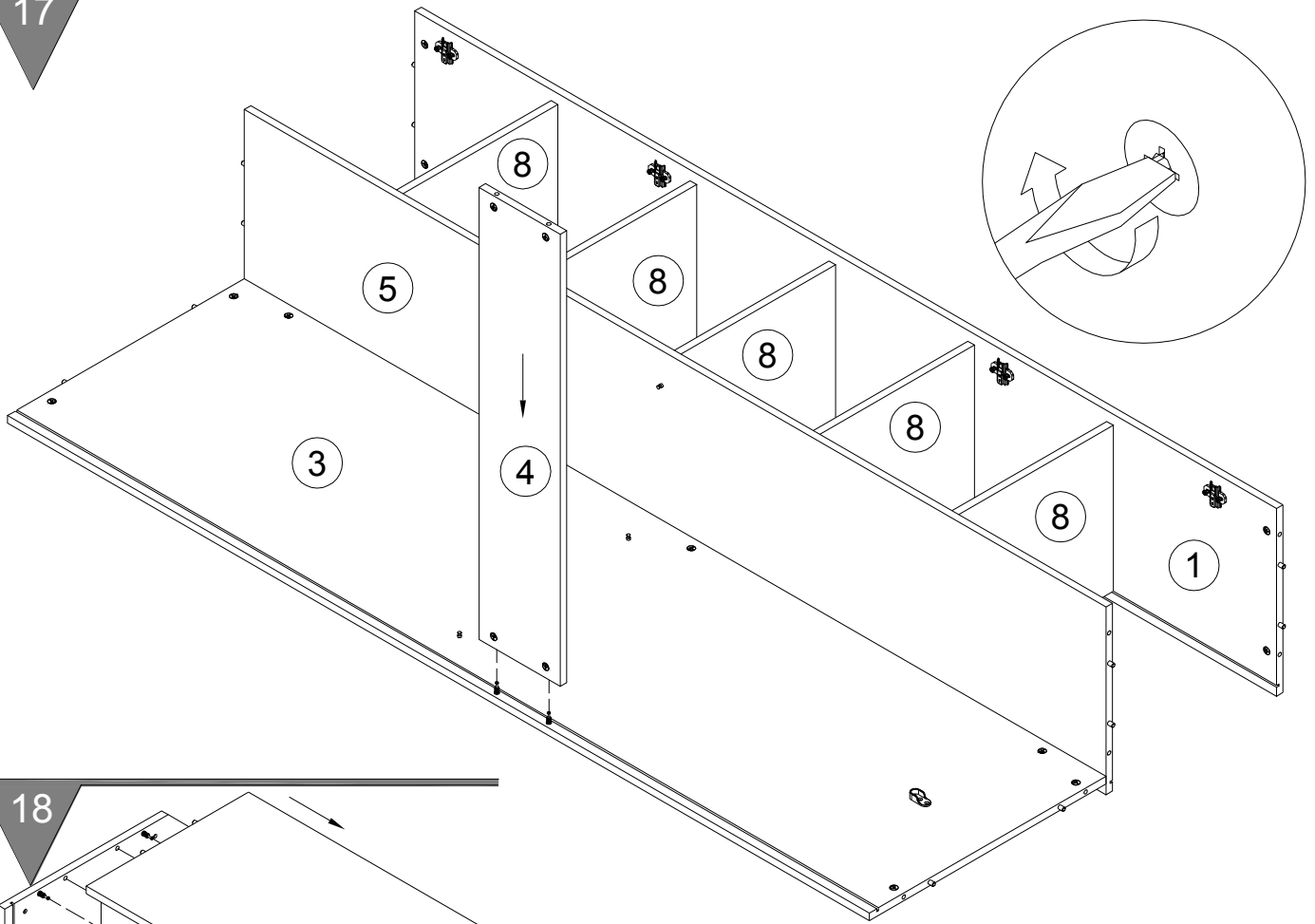

18

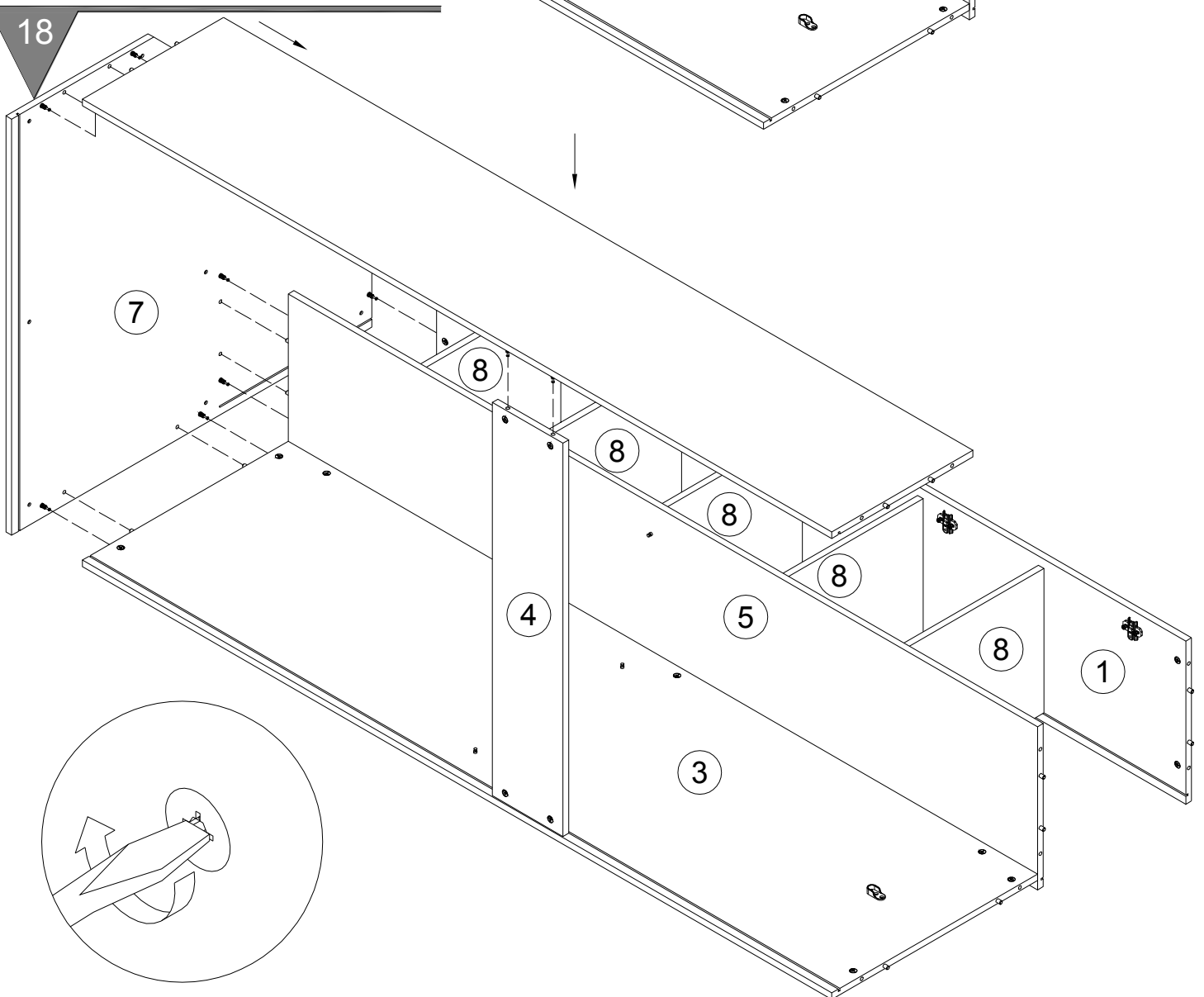

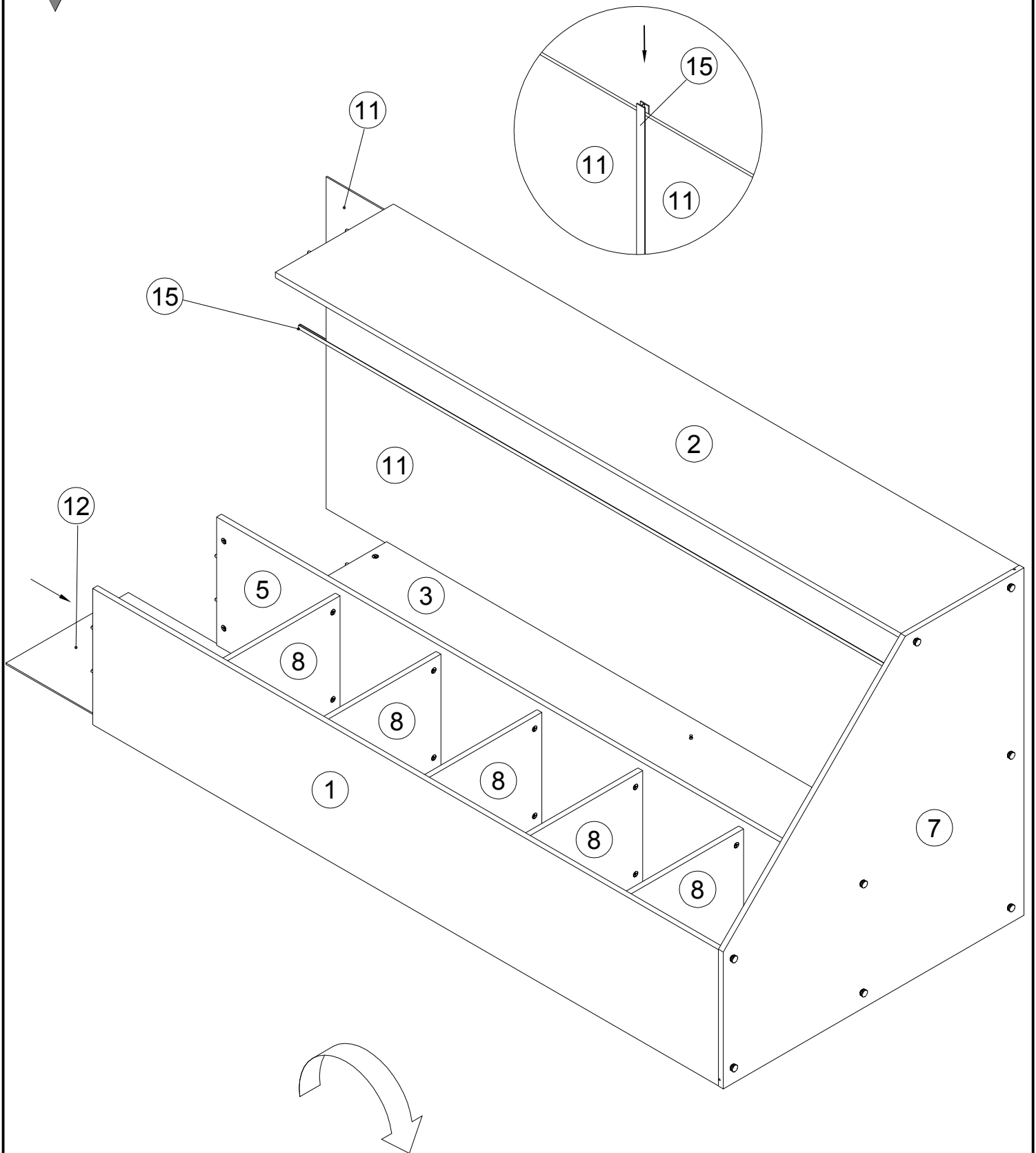

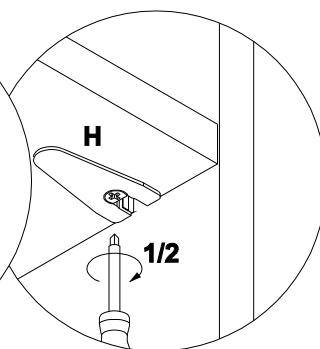
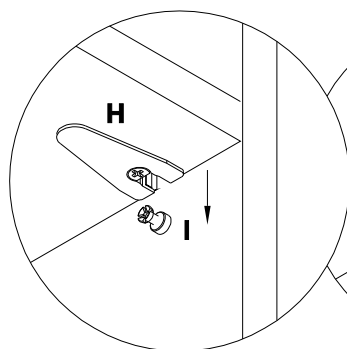
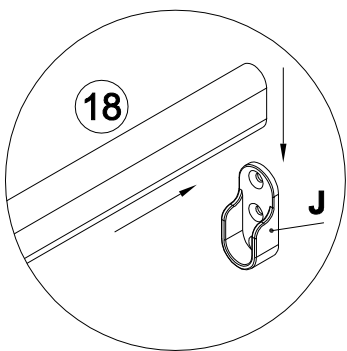
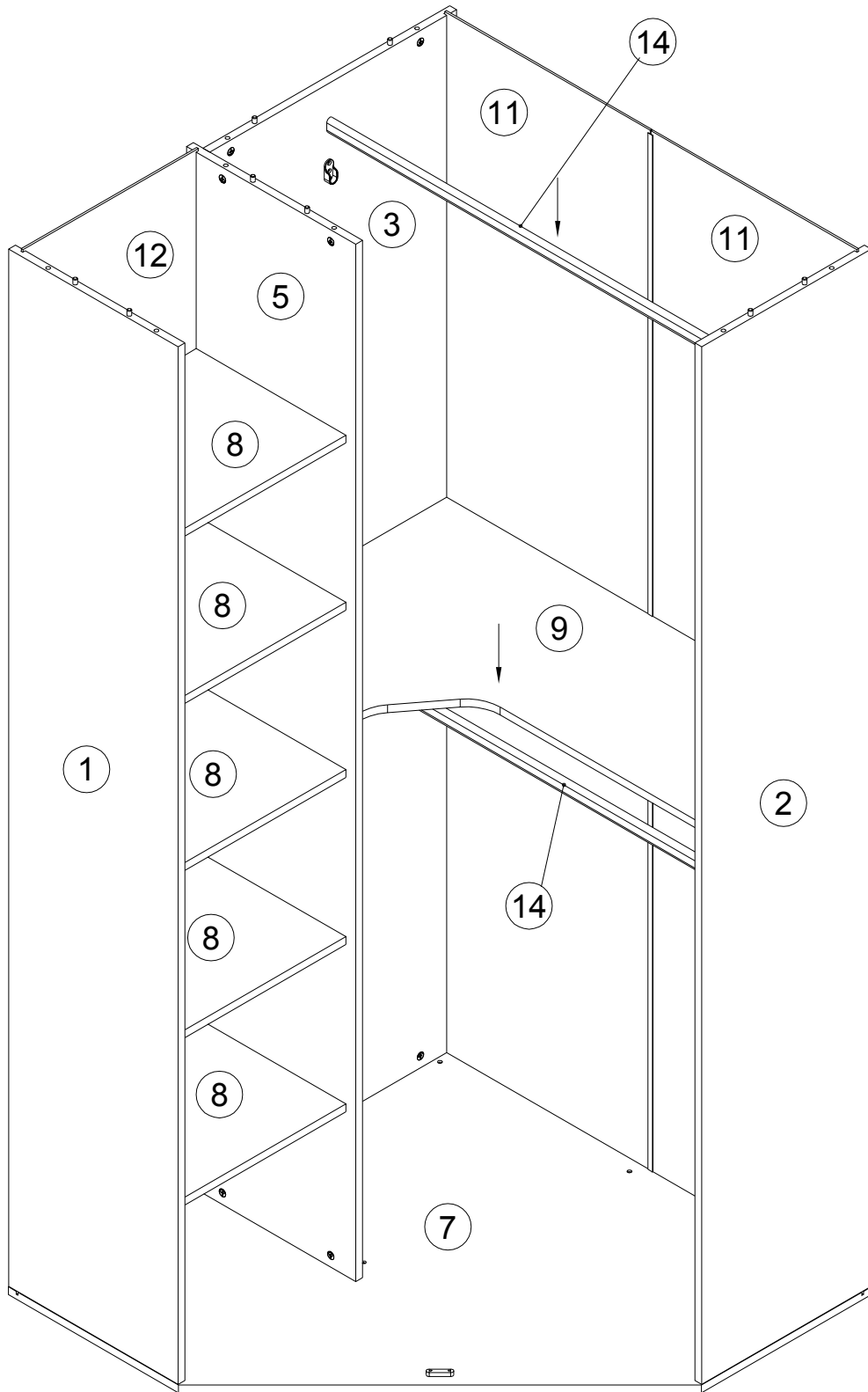



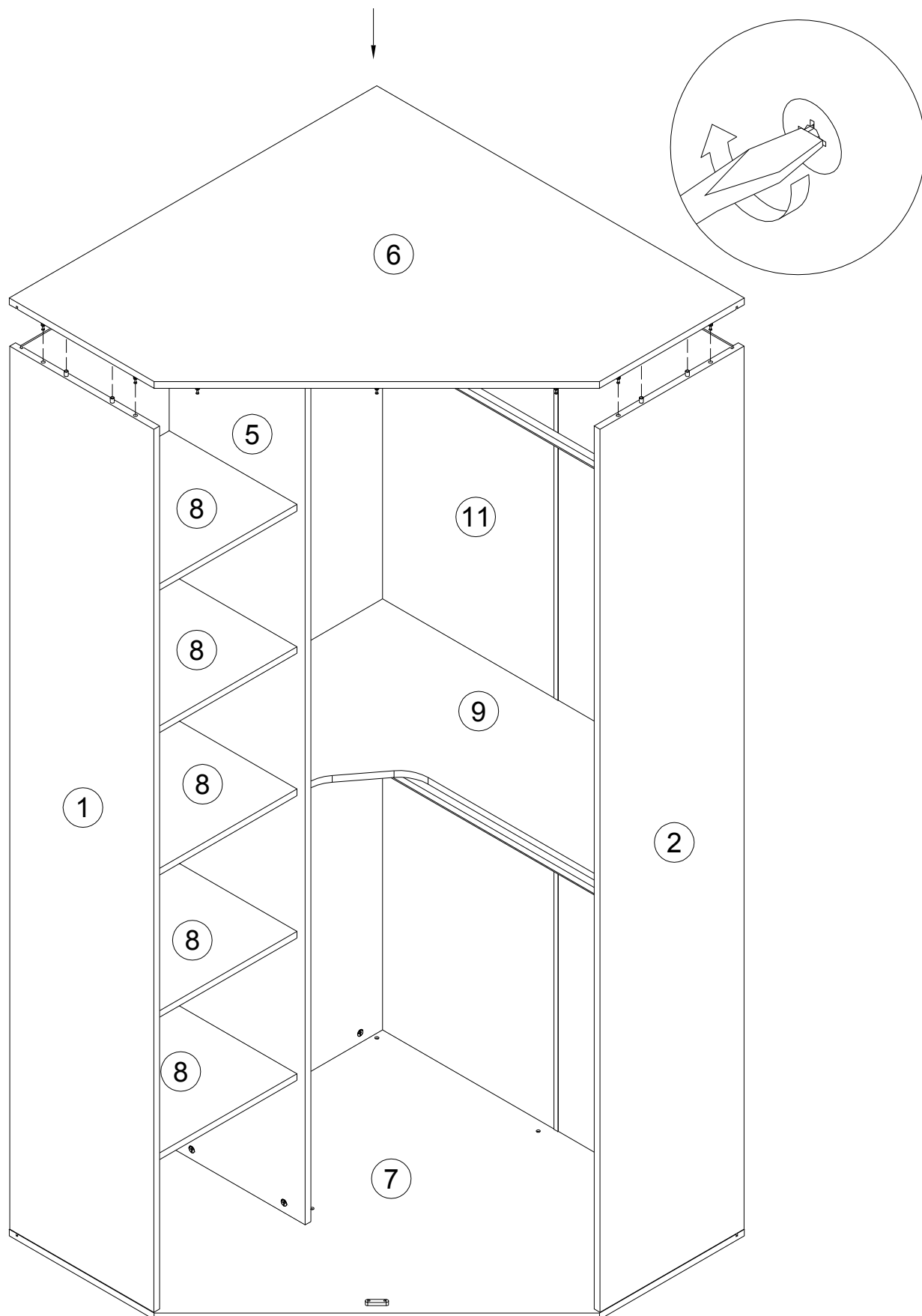

155999

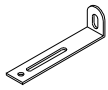

x1

000754



3.5x16

x2

013859



8x40

x1

090185



4.5x45

x1

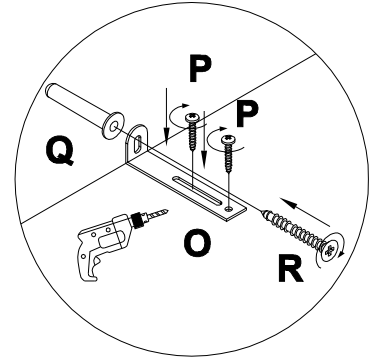

O,P,Q,R

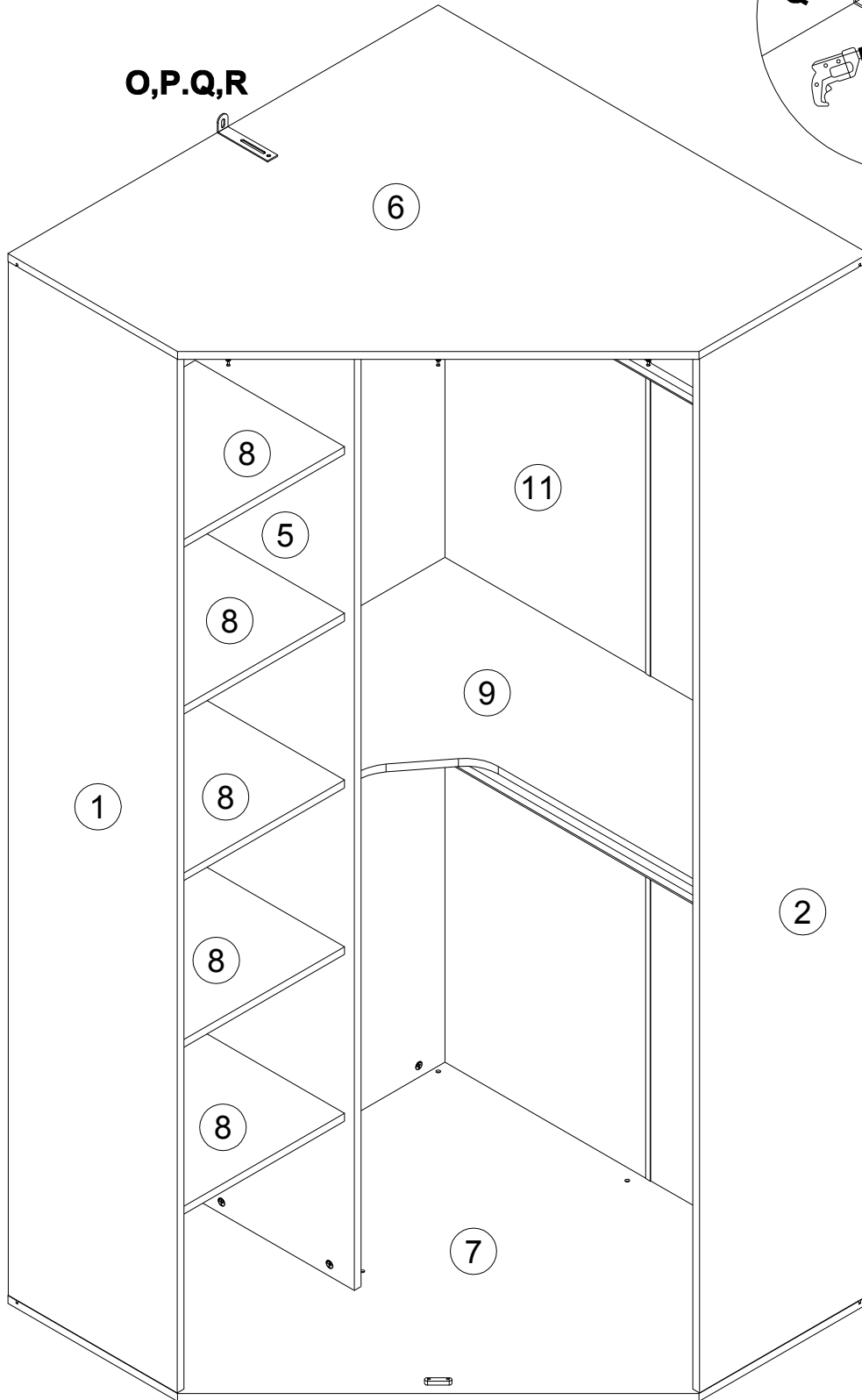

23

M  
196160



x1

N  
000753



3x13

x2

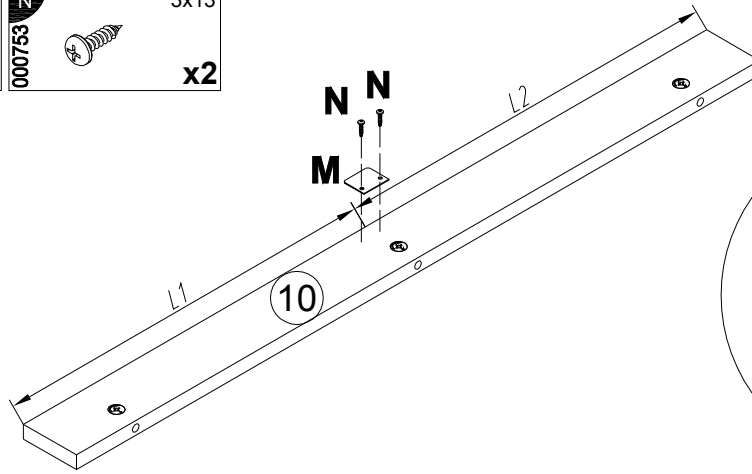

24

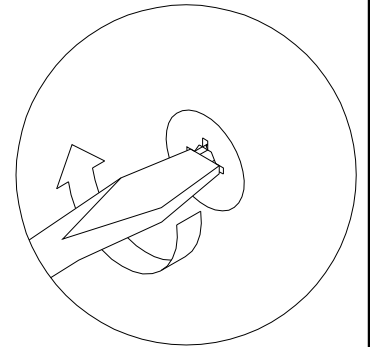
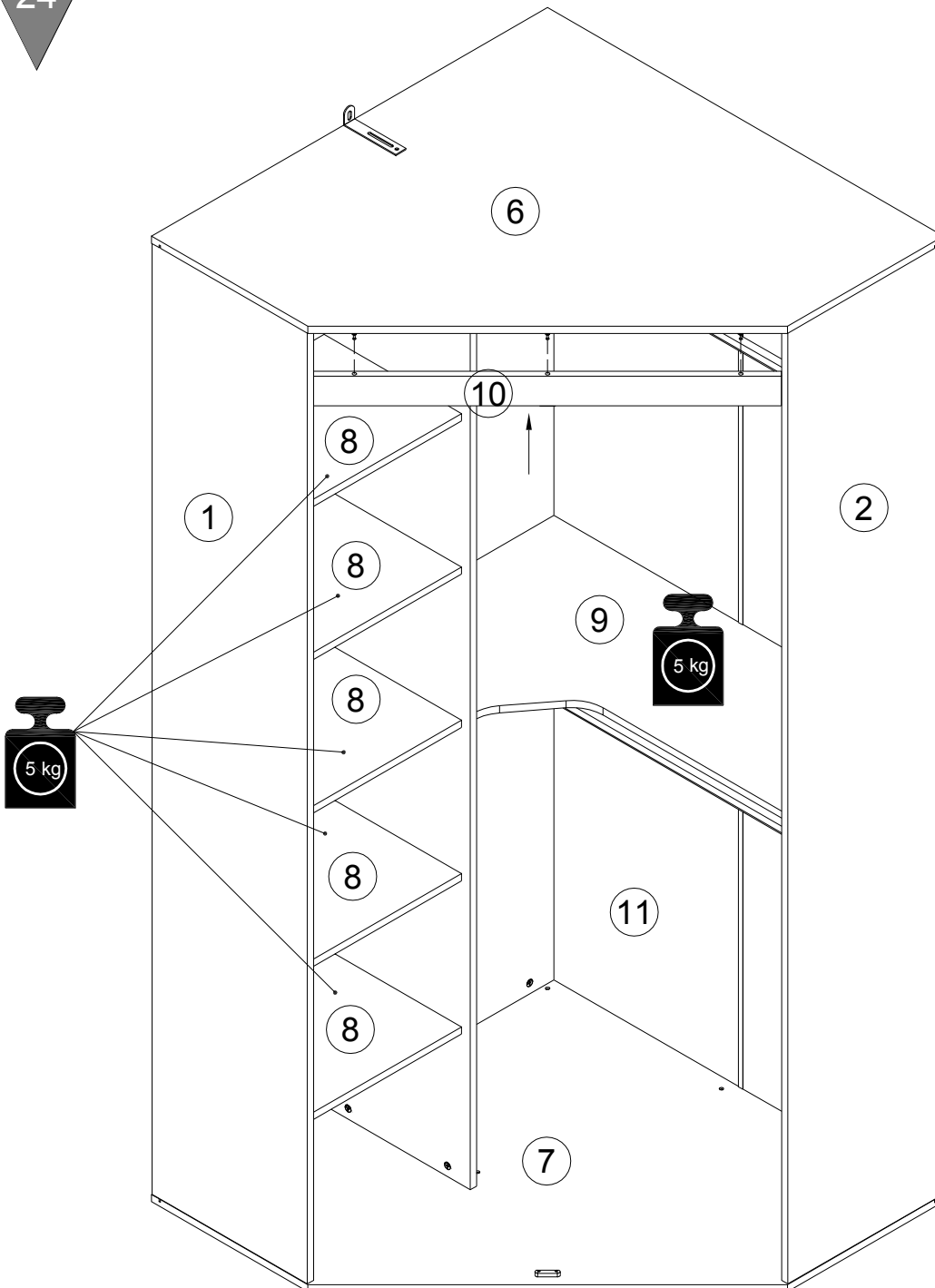

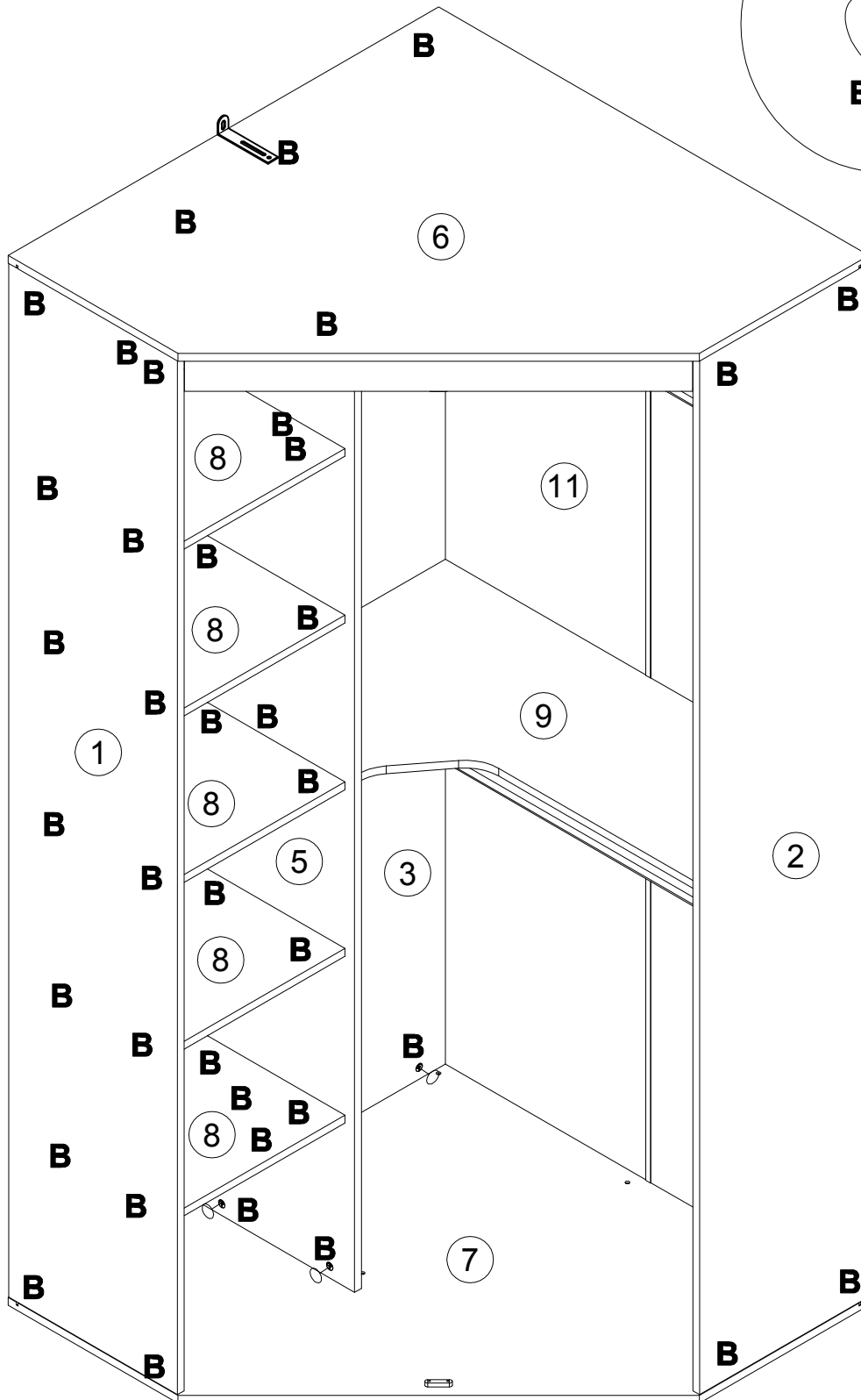
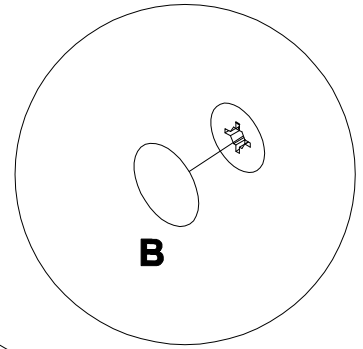



x2



M4x20

x2

## Шкаф арт. 169H022

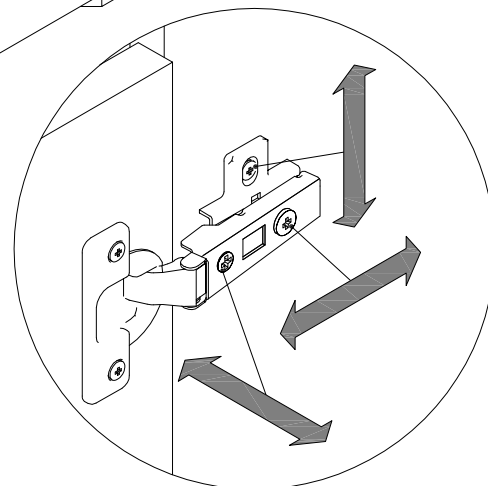
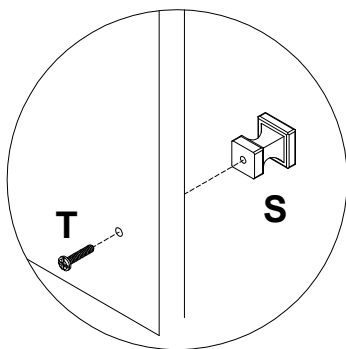
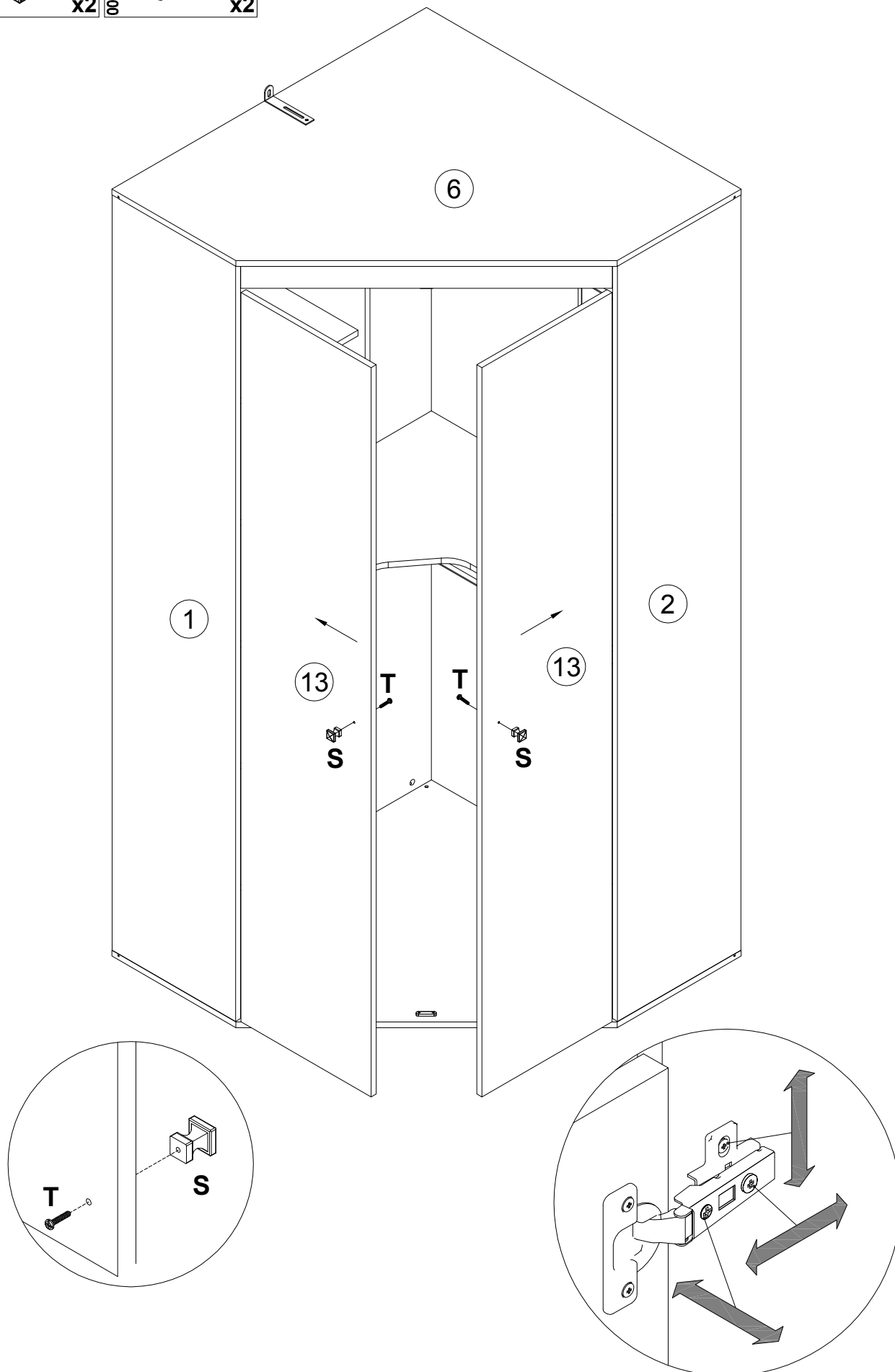

27

194064



x2

002704



M4x20

x2

# Шкаф арт. 170H022

