

RANDERS

RANDERS, 2door wardrobe, 99x61x214 cm
RANDERS, Skapis ar 2 durvīm, 99x61x214 cm
RANDERS, Spinta su 2 durelėmis, 99x61x214 cm
RANDERS, Кapp 2 укseга, 99x61x214 cm
RANDERS, Шкаф 2-дверный, 99x61x214 cm

701-176-1015

701-176-1016

701-176-1017



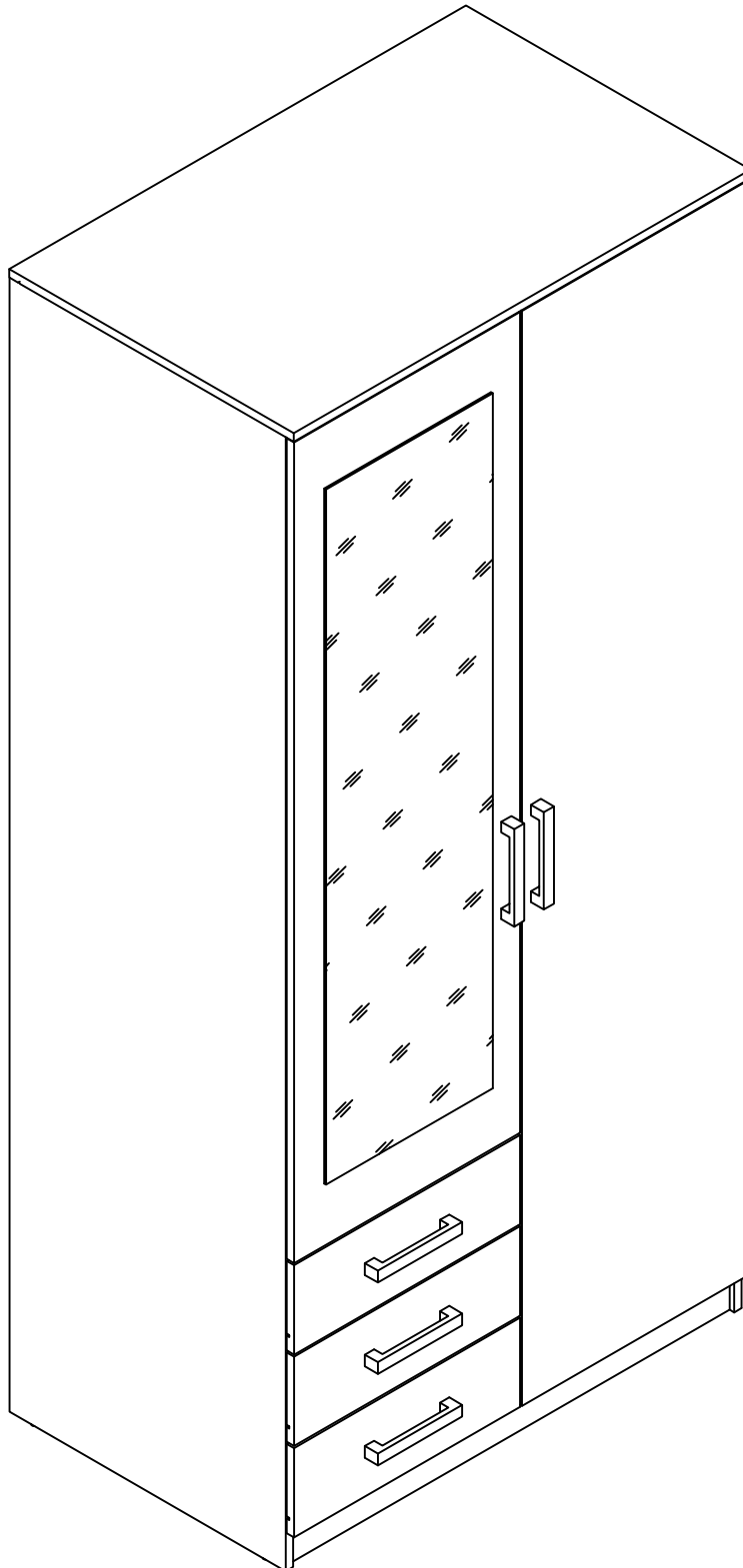







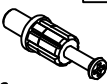







701-176-1018

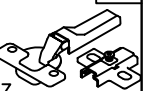

Детали / Detaļas / Detalē / Detailid

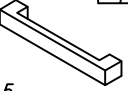
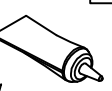
№	Наименование	Nosaukums	Pavadinimas	Nimi	Кол-во/ Daudzums / Kiekis / Kogus	LxBxH
1	Стенка боковая	Sānu siena	Šoninė sienelė	Kūlgsein	1	2122x596x16
2	Стенка боковая	Sānu siena	Šoninė sienelė	Kūlgsein	1	2122x596x16
3	Стенка боковая	Sānu siena	Šoninė sienelė	Kūlgsein	3	500x118x12
4	Стенка боковая	Sānu siena	Šoninė sienelė	Kūlgsein	3	500x118x12
5	Стенка задняя	Aizmugures siena	Užpakalinė sienelė	Tagasein	3	419x118x12
6	Стенка передняя	Priekšējā siena	Priekinė sienelė	Esisein	2	952x60x16
7	Стенка передняя	Priekšējā siena	Priekinė sienelė	Esisein	3	488x167x16
8	Стенка задняя	Aizmugures siena	Užpakalinė sienelė	Tagasein	1	952x200x16
9	Стенка-перегородка	Starpsiena	Pertvarinė sienelė	Vahesein	1	572x514x16
10	Стенка горизонтальная	Horizontālā siena	Horizontali sienelė	Horizontaalsein	1	952x572x16
11	Стенка горизонтальная	Horizontālā siena	Horizontali sienelė	Horizontaalsein	1	986x614x16
12	Стенка горизонтальная	Horizontālā siena	Horizontali sienelė	Horizontaalsein	1	572x468x16
13	Дверь	Durvis	Durys	Uks	1	1535x488x21
14	Дверь	Durvis	Durys	Uks	1	2048x488x16
15	Планка	Planka	Juostelė	Liist	1	2041
16	Стенка задняя ДВП	Aizmugures siena	Užpakalinė sienelė	Tagasein PKP	2	2067x480x3
17	Стенка горизонтальная ДВП	Horizontālā siena	Horizontālā siena	Horizontaalsein PKP	3	497x429x3
18	Штанга-труба	Caurulveida stienis	Vamzdinis strypas	Riidepuutoru	1	947
19	Стенка горизонтальная	Horizontālā siena	Horizontali sienelė	Horizontaalsein	1	952x572x16

Фурнитура / Furnitūra / Furnitūra / Manused

 22	 22	 6	 52	 1	 2 3.5x16	 14 3x20	 28 4x16	 10 4x30
 10	 7	 10	 2	 3 L 500	 5	 1	 4	 22 3.5x13
								 18 3x13

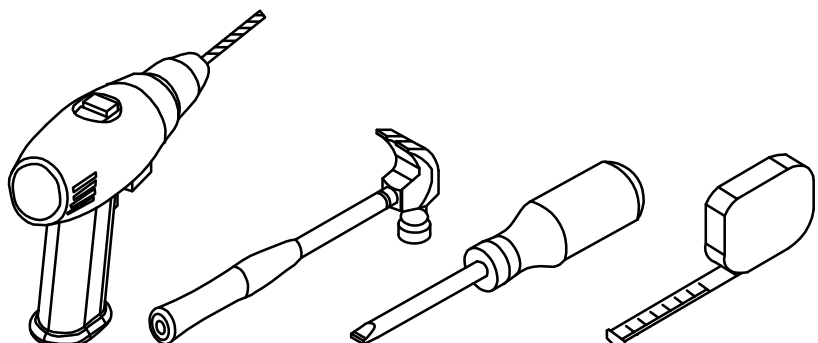
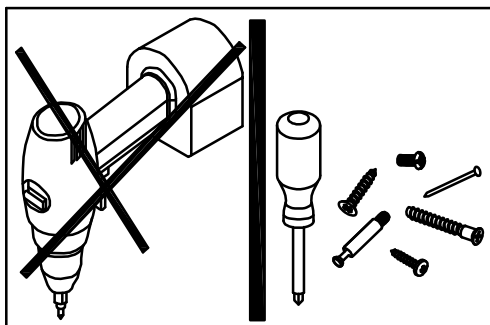
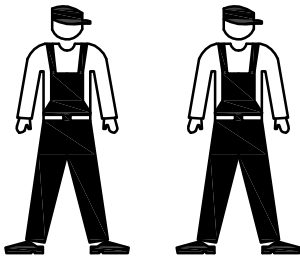

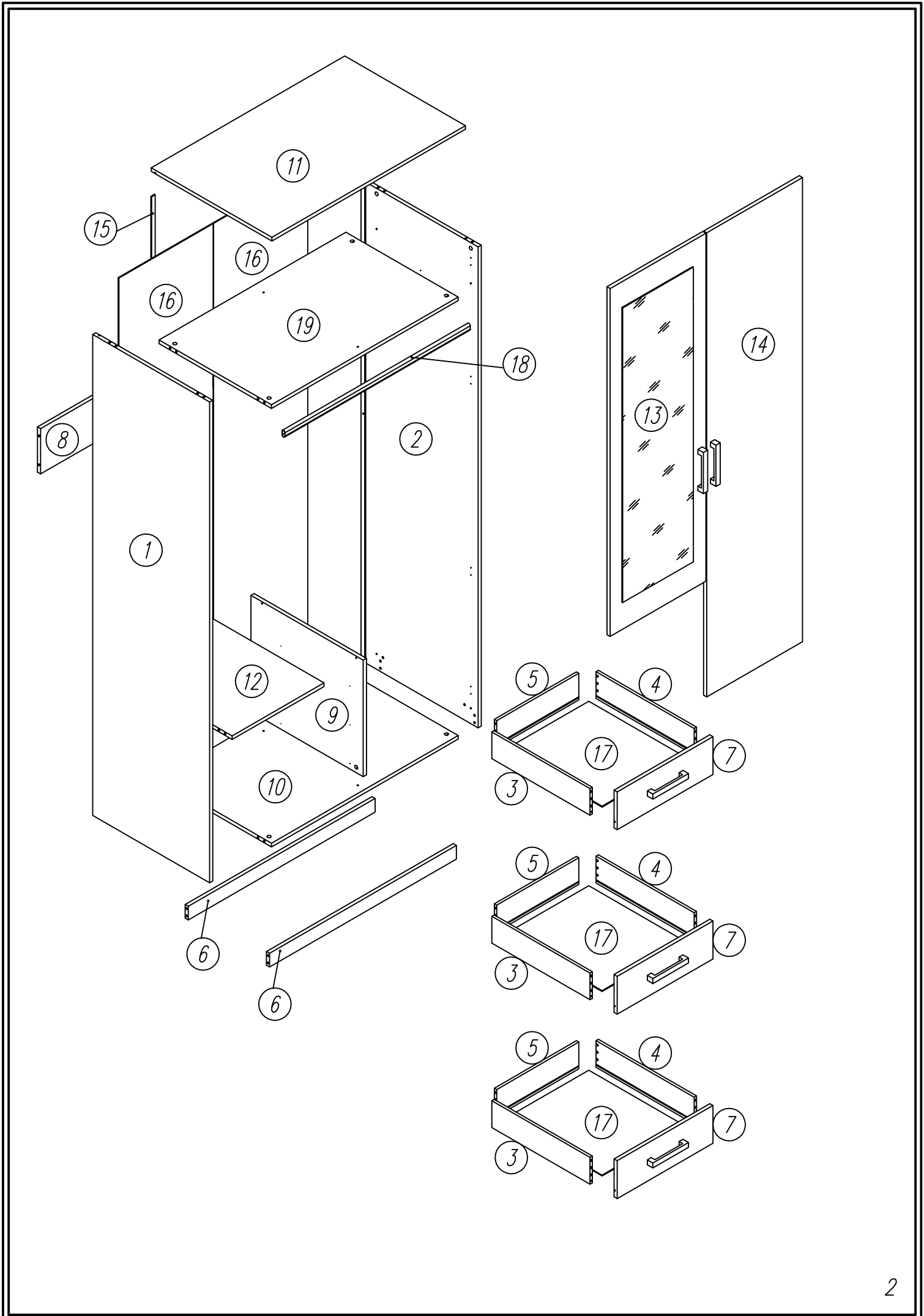

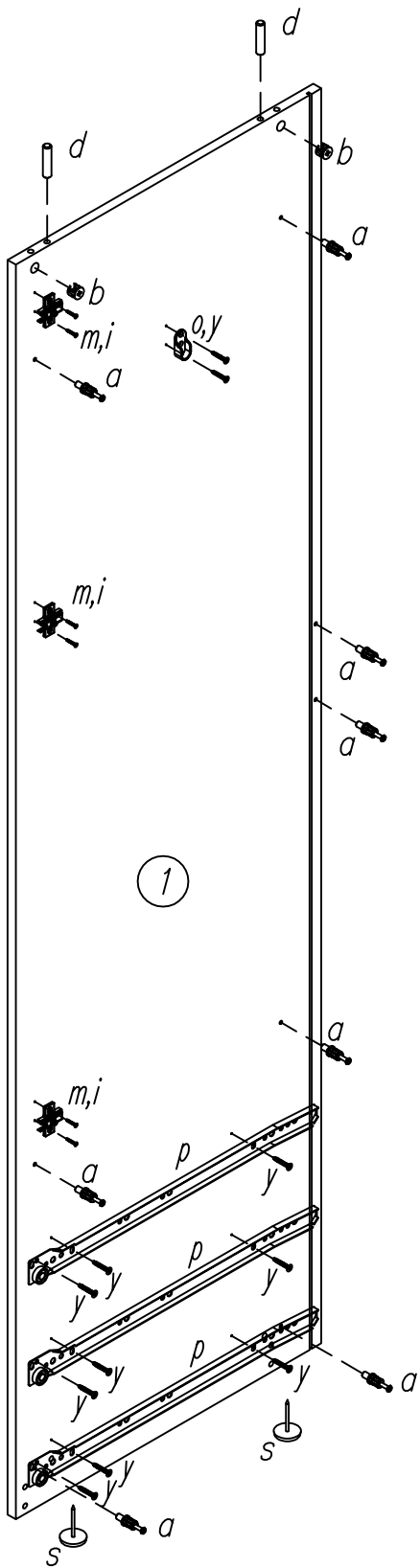

1

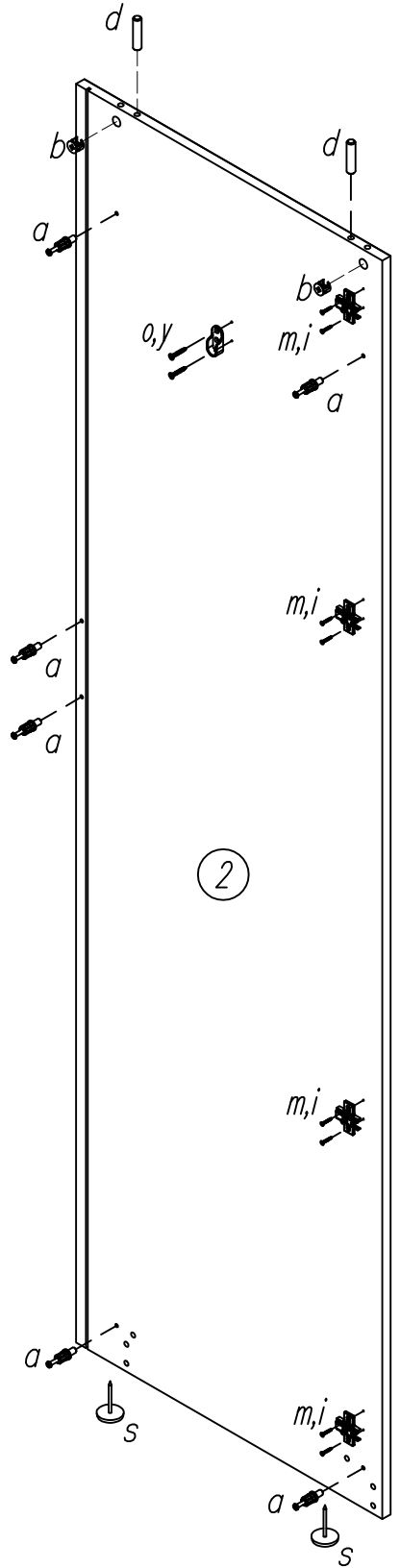
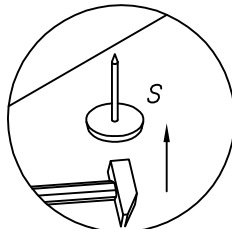
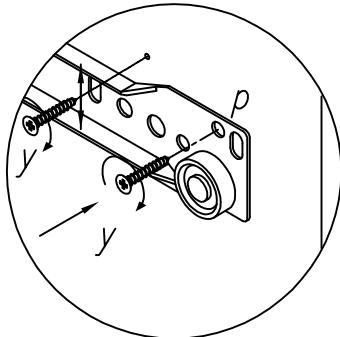
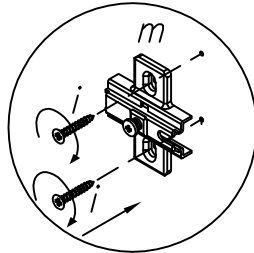
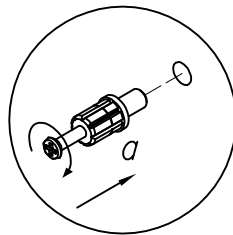
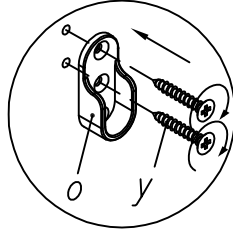
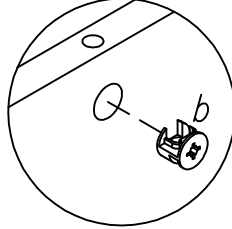
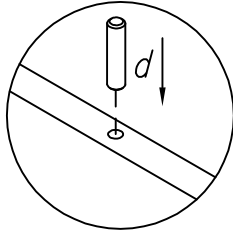

2

2

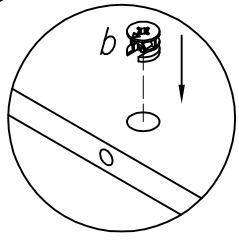
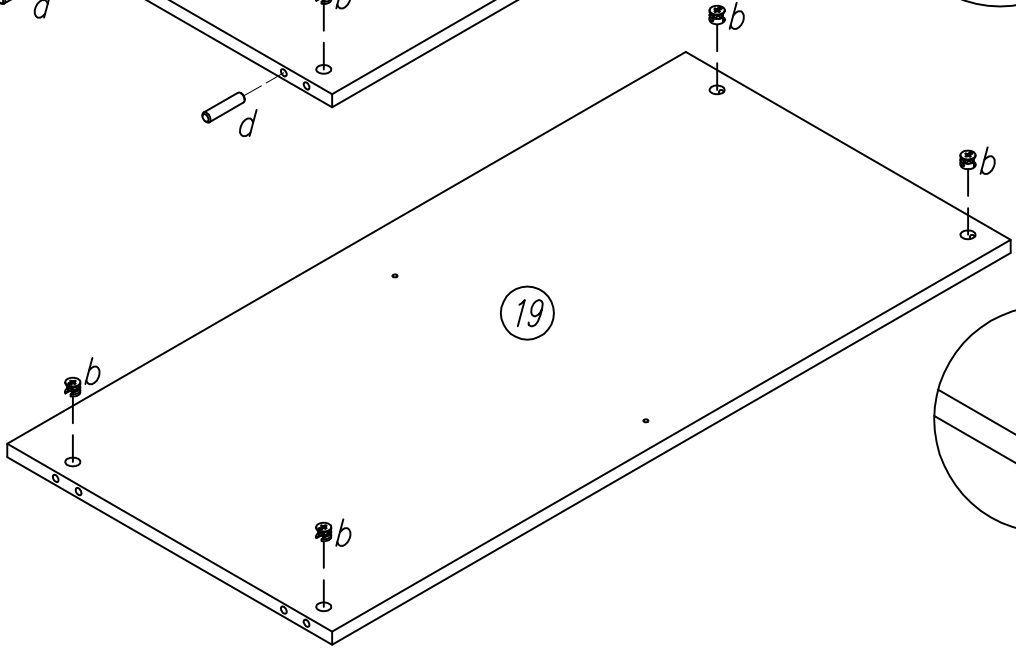
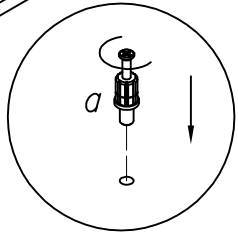
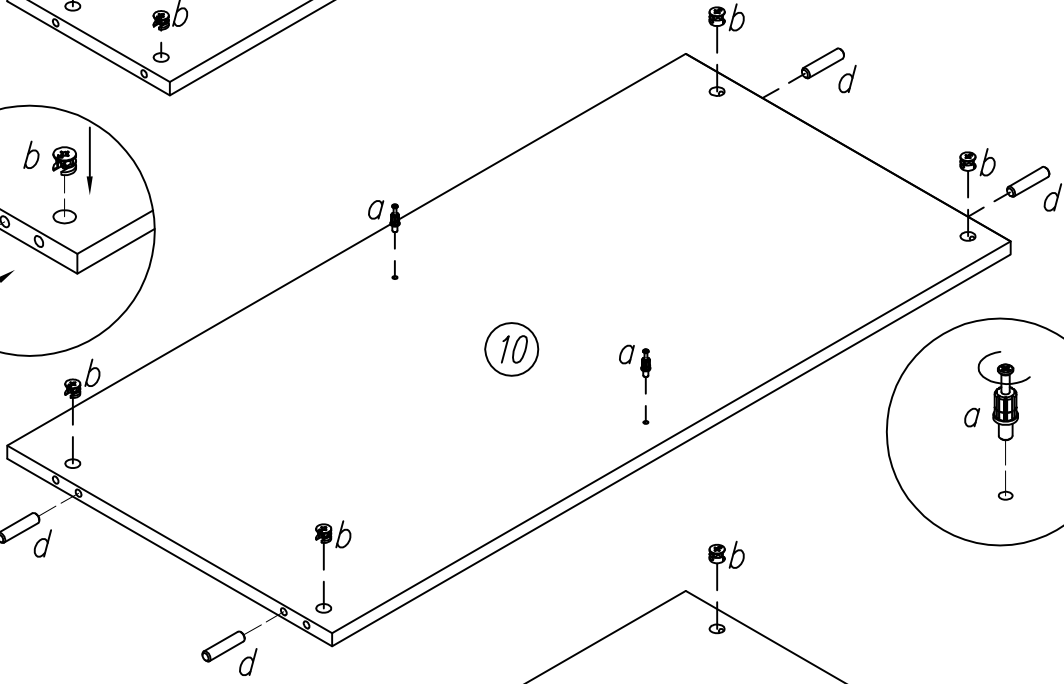
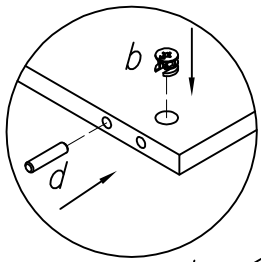
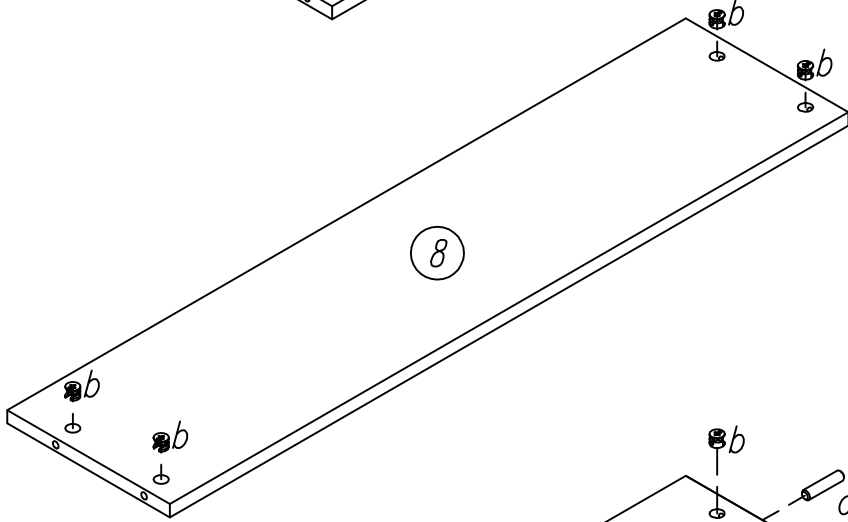
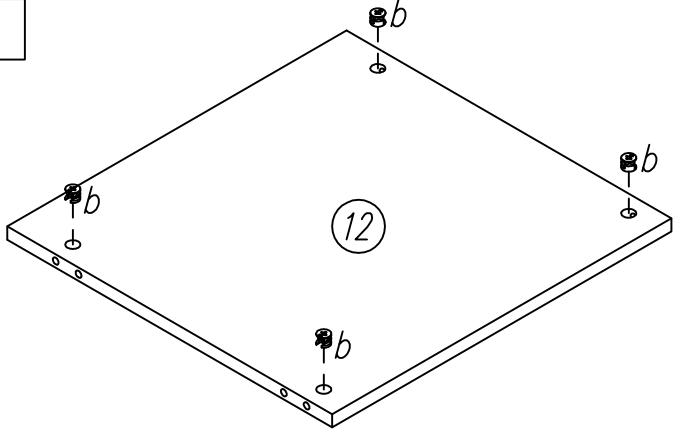

3

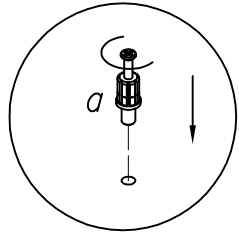
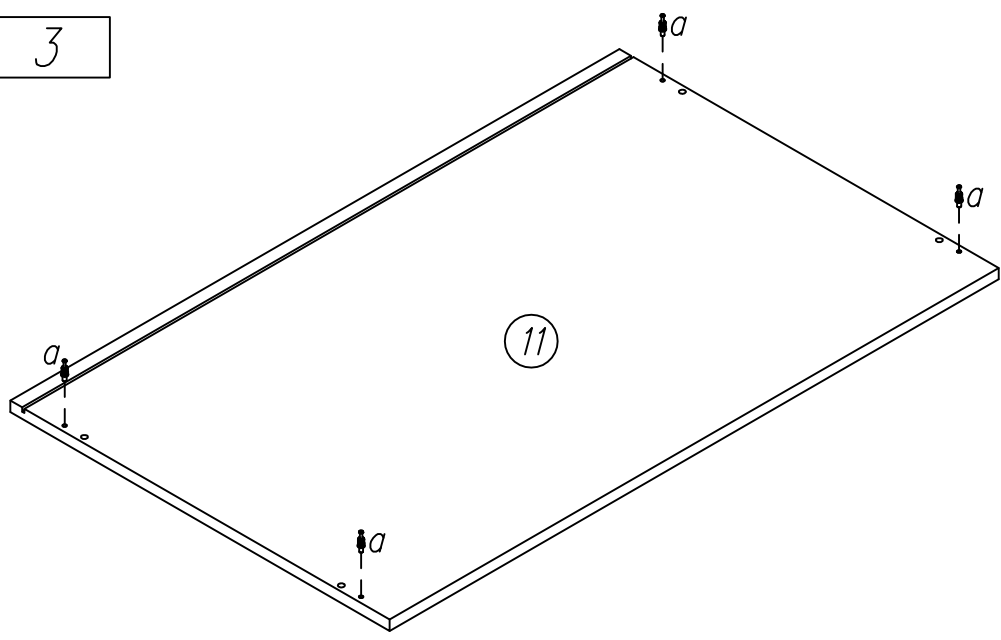

4

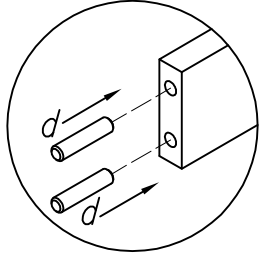
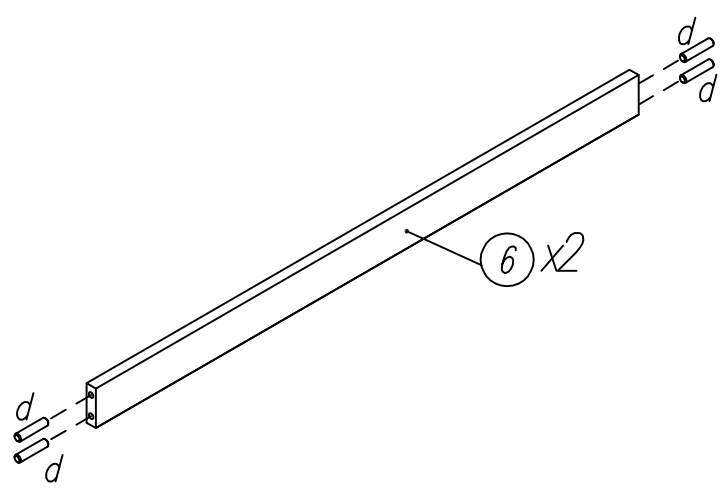

5

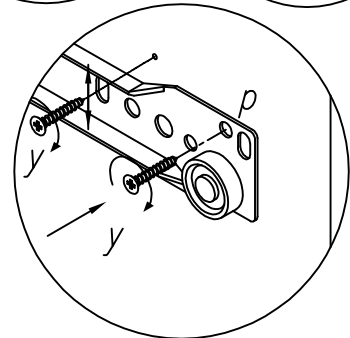
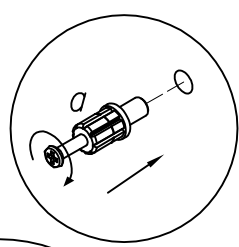
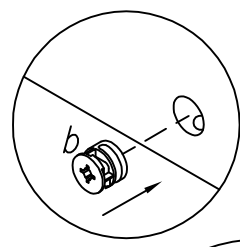
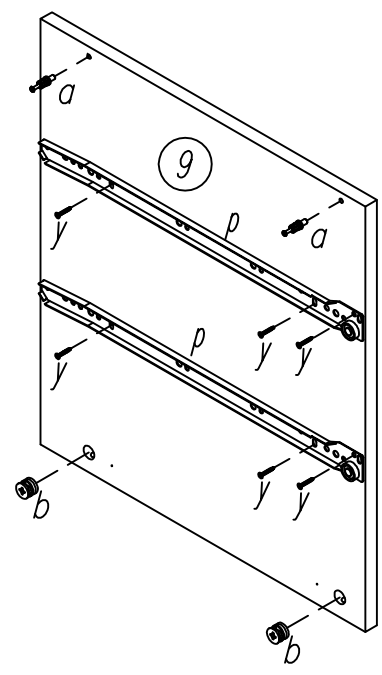

6

x3

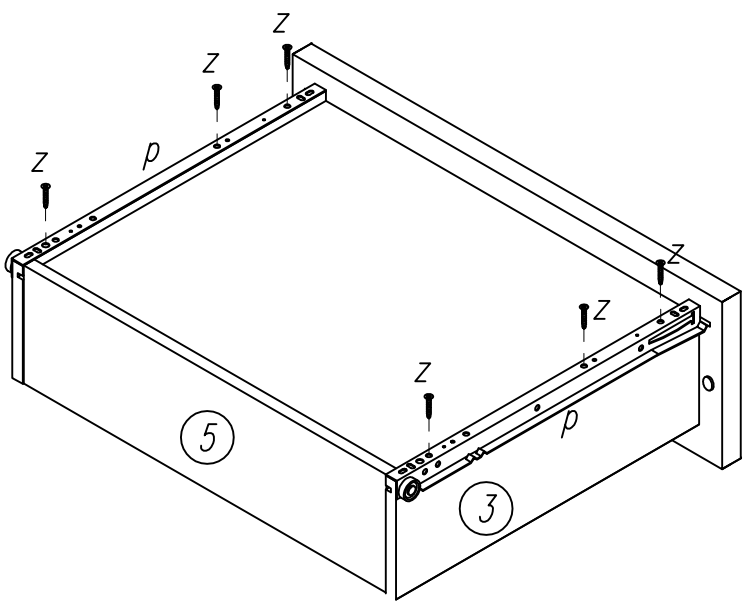
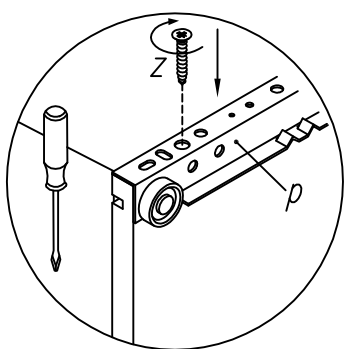
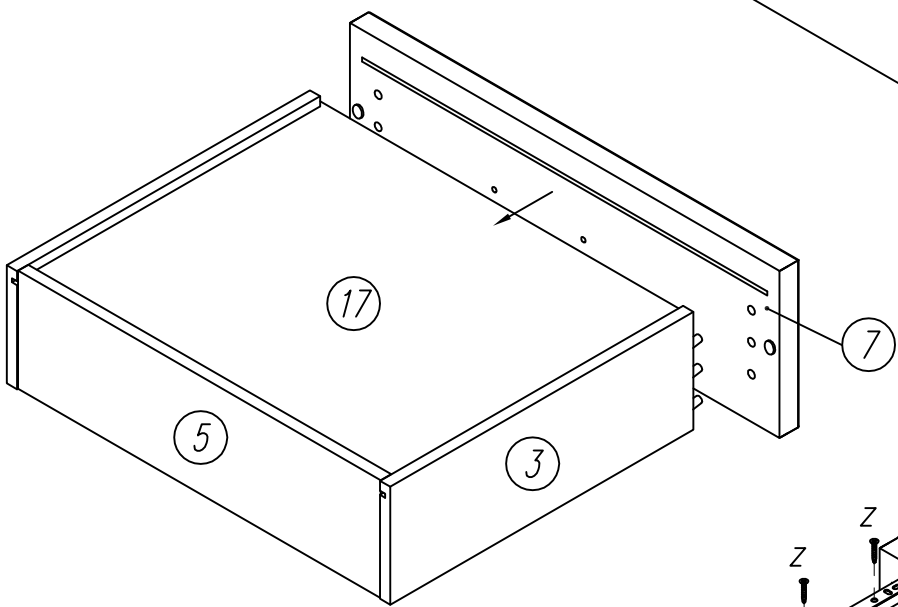
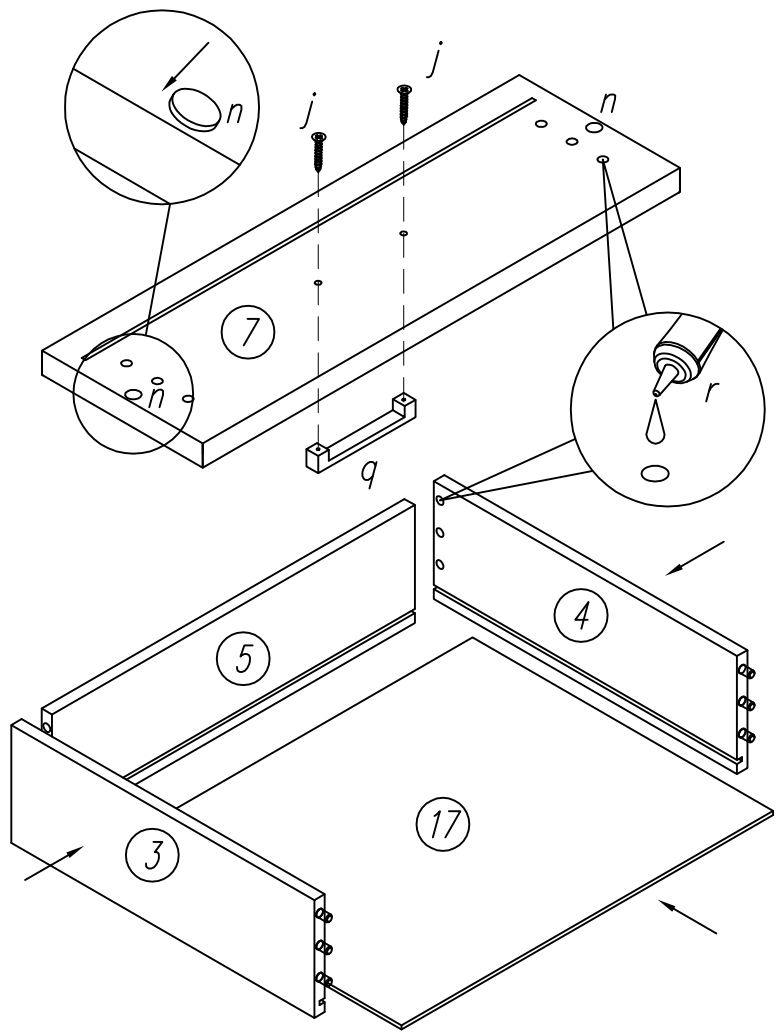
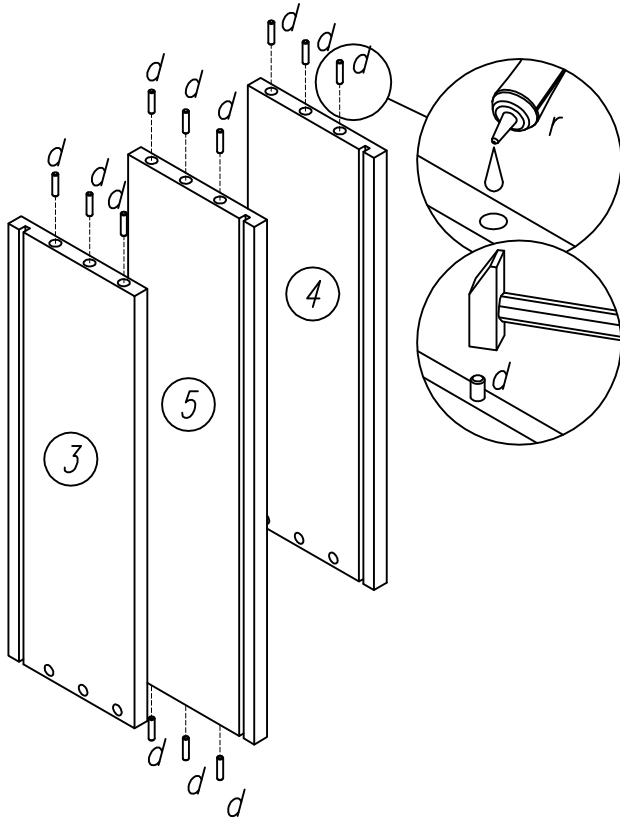

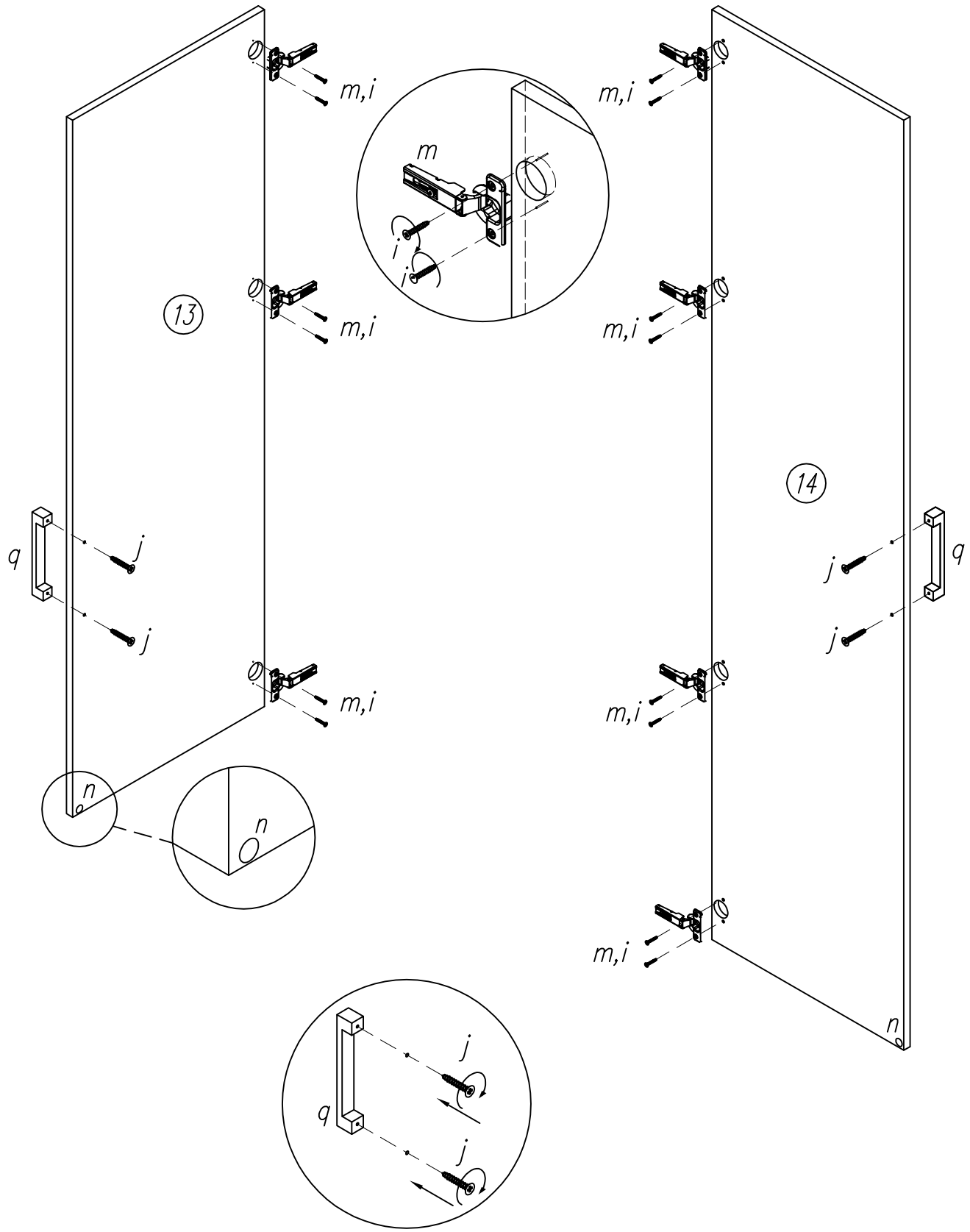

8

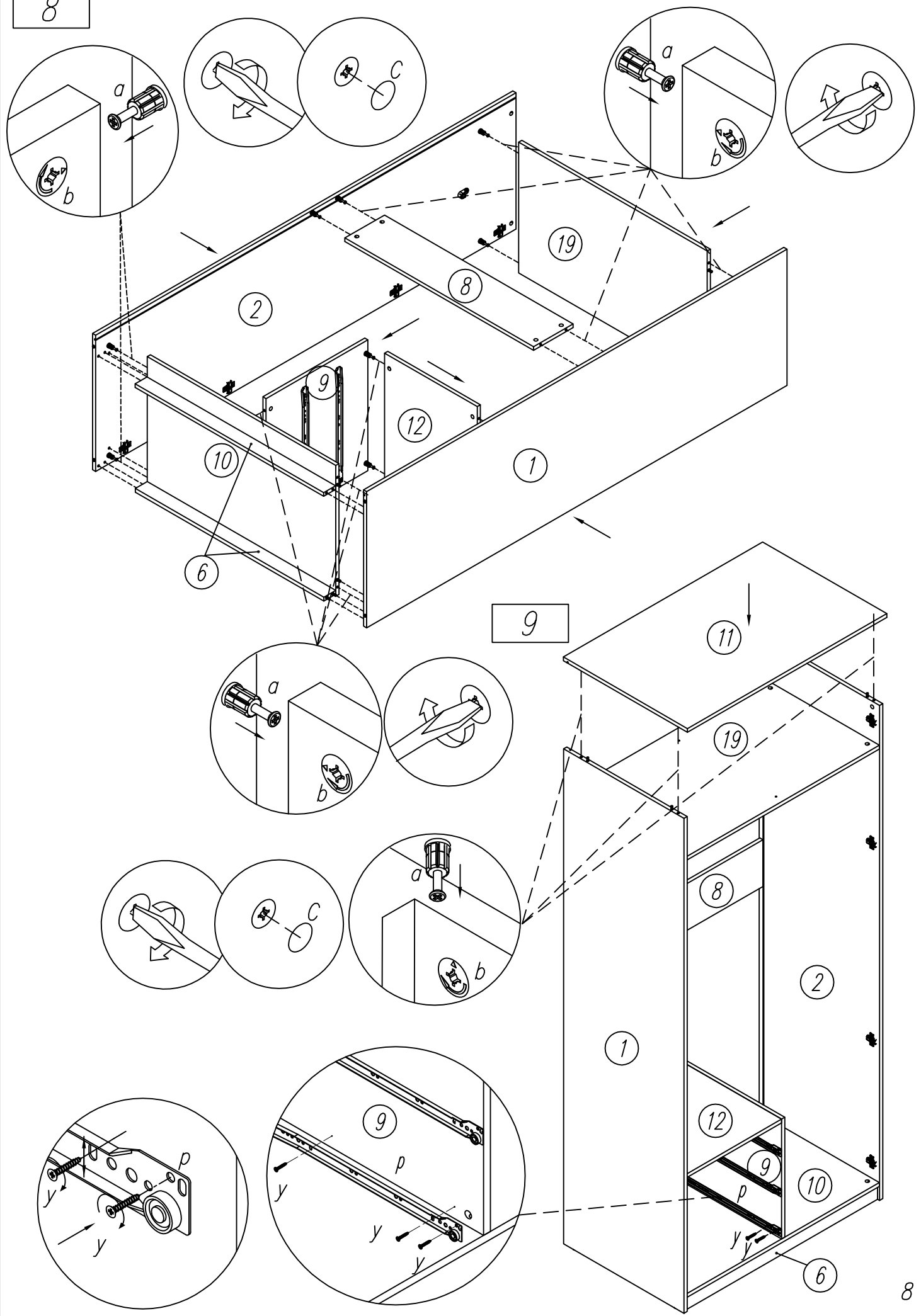

10

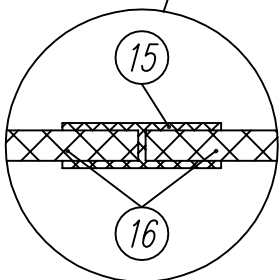
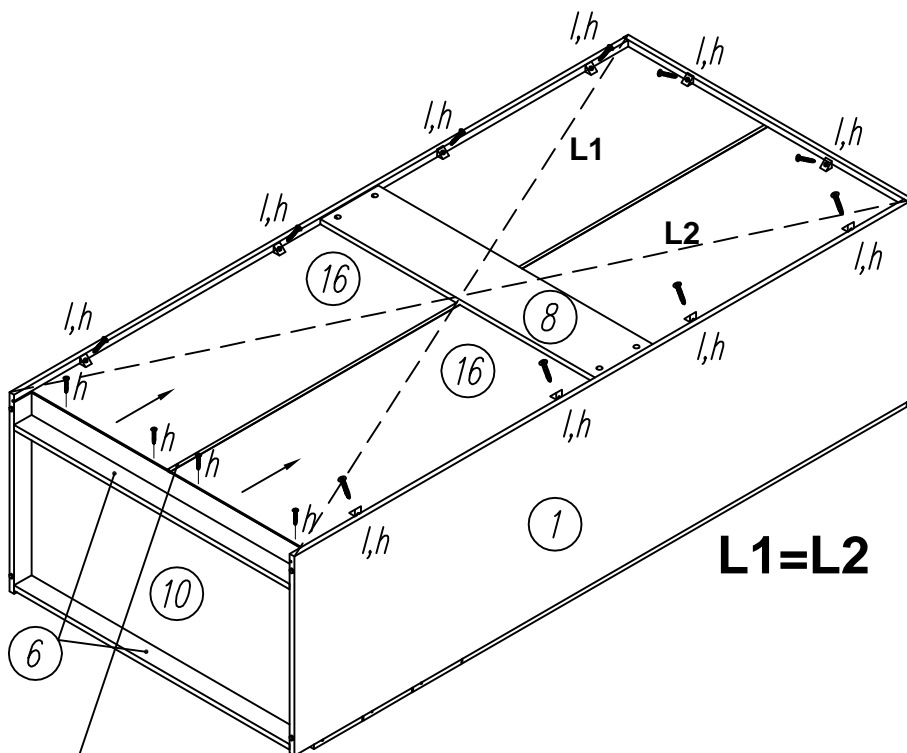
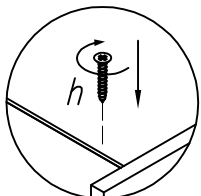
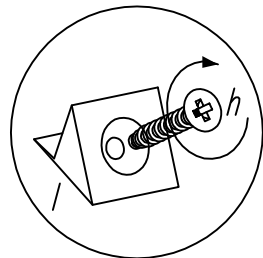

11

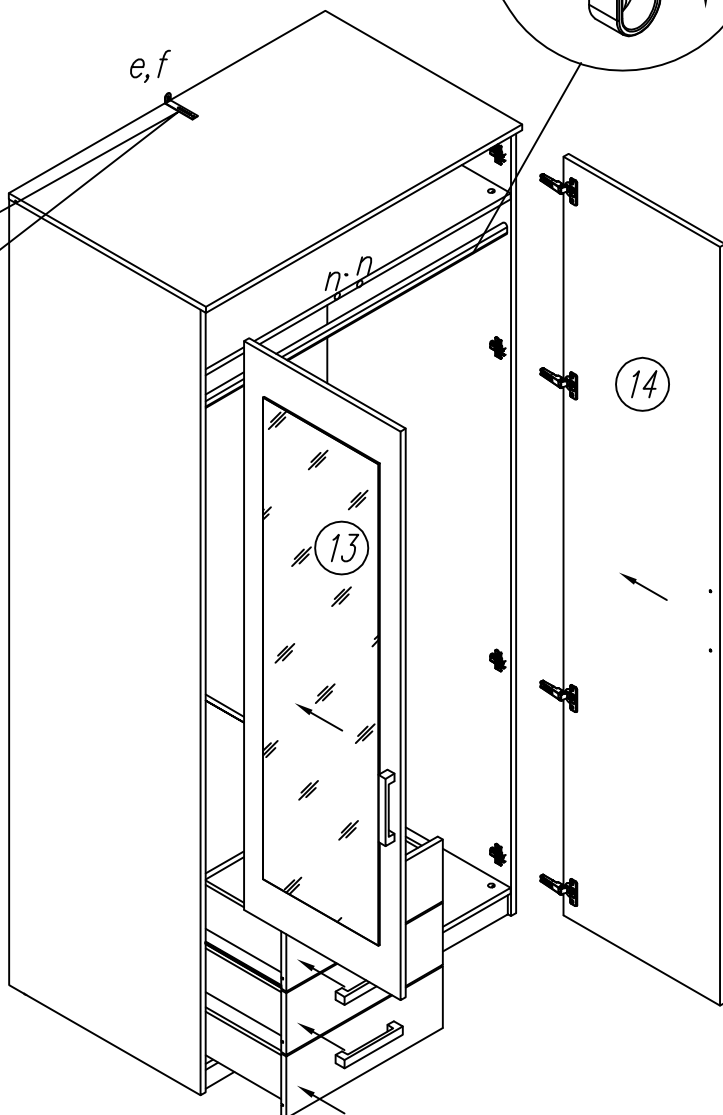
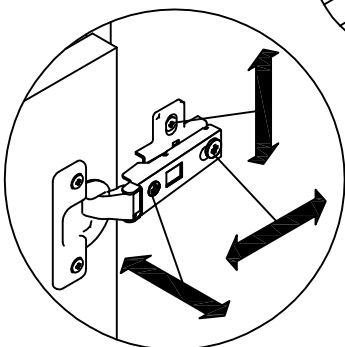
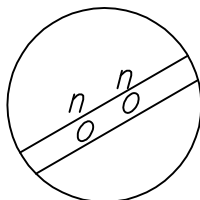
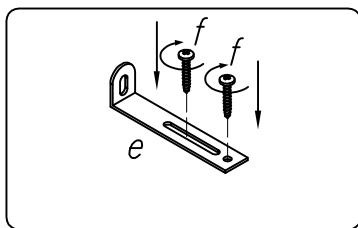
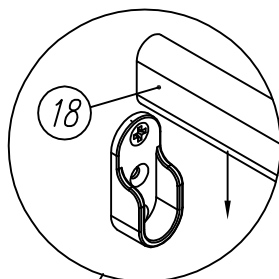

GB:

IMPORTANT INFORMATION!

Please read the entire manual carefully before starting to assemble and/or using this product. Follow the manual thoroughly and keep it for further reference.

LV:

SVARĪGA INFORMĀCIJA!

Pirms montāžas un/vai produkta lietošanas, lūdzu, rūpīgi izlasiet lietošanas instrukciju. Rūpīgi ievērojiet lietošanas instrukcijas norādījumus, kā arī saglabājiet to turpmākai uzziņai.

LT:

SVARBI INFORMACIJA!

Prieš pradėdami surinkti šį gaminį ir (arba) juo naudotis, atidžiai perskaitykite visą vadovą. Laikykitės vadove pateikiamų nurodymų ir pasilikite jį ateičiai.

ET:

OLULINE TEAVE!

Enne toote kokku monteerimist ja/või kasutamist lugege kogu kasutusjuhend hoolikalt läbi. Järgige täpselt kasutusjuhendis toodud juhiseid ja hoidke juhend alles.

BY(RU):

ВАЖНАЯ ИНФОРМАЦИЯ!

Внимательно и полностью прочитайте это руководство, прежде чем приступать к сборке или использованию этого изделия. Следуйте всем инструкциям этого руководства и сохраните его на будущее для справки.

GB:

ANTI-TOPPLE WARNING!

This product has to be permanently fixed to the wall with the bracket(s) included, to avoid fatal injury in case topples over. The pack only contains screws for fastening the anti topple bracket(s) itself to the product. Please contact your DIY or hardware store for advice on the correct type of screws/raw plugs for your type of wall.

LV:

BRĪDINĀJUMS PAR APGĀŠANOS!

Šis produkts ir jāpiestiprina pie sienas ar komplektā iekļauto(-ajiem) kronšteinu(-iem), lai novērstu nāvējošu savainojumu risku, tam apgāžoties. Iepakojuma ir skrūves tikai pretapgāšanās kronšteina(-u) piestiprināšanai pie produkta. Informāciju par to, kādas skrūves piemērotas Jūsu sienai, jautājiet saimniecības preču vai būvizstrādājumu veikalā.

LT:

ĮSPĖJIMAS DĖL NUVIRTIMO!

Šį gaminį būtina tinkamai pritvirtinti prie sienos naudojant pridėtas gembes, kad išvengtumėte mirtino sužalojimo jam nuvirtus. Pakuotėje yra tik varžtai gembėms prie gaminio pritvirtinti. Užeikite į artimiausią statybinių prekių parduotuvę ir paprašykite savo sienai tinkamiausių varžtų (kaiščių).

ET:

ÜMBERKUKKUMISOHT!

Toote ümberkukkumisest tuleneda võiva eluohtliku õnnetuse vältimiseks tuleb see kinnitada komplekti kuuluva(te) kronsteini(de) abil püsivalt seina külge. Komplekti kuuluvad ainult kruvid, mis on mõeldud ümberkukkumist takistava(te) kronsteini(de) kinnitamiseks toote külge. Soovituste saamiseks sobivate kruvide/tüüblite leidmiseks oma seina jaoks, konsulteerige DIY esindaja või rauakaupade kaupluse müüjaga.

BY(RU):

ПРЕДУПРЕЖДЕНИЕ: ЗАЩИТА ОТ ОПРОКИДЫВАНИЯ!

В целях предотвращения смертельных травм это изделие необходимо прочно прикрепить к стене с помощью входящих в комплект скоб. В комплект входят только винты, необходимые для крепления скоб, предназначенных для защиты от опрокидывания. Пожалуйста, обратитесь в местный специализированный магазин или магазин строительных материалов за консультацией относительно винтов/дюбелей, подходящих для ваших стен.