

# 581i DI Combo and 581i HD DI Combo Operations Manual

531966-2EN\_A



 **HUMMINBIRD**

**500 series™**

## Thank You!

---

Thank you for choosing Humminbird®, the #1 name in fishfinders. Humminbird® has built its reputation by designing and manufacturing top-quality, thoroughly reliable marine equipment. Your Humminbird® is designed for trouble-free use in even the harshest marine environment. In the unlikely event that your Humminbird® does require repairs, we offer an exclusive Service Policy - free of charge during the first year after purchase, and available at a reasonable rate after the one-year period. For complete details, see the separate warranty card included with your unit. We encourage you to read this operations manual carefully in order to get full benefit from all the features and applications of your Humminbird® product.

To contact our Customer Resource Center, call **1-800-633-1468** or visit our Web site at **humminbird.com**.

**WARNING!** *This device should not be used as a navigational aid to prevent collision, grounding, boat damage, or personal injury. When the boat is moving, water depth may change too quickly to allow time for you to react. Always operate the boat at very slow speeds if you suspect shallow water or submerged objects.*

**WARNING!** *The electronic chart in your Humminbird® unit is an aid to navigation designed to facilitate the use of authorized government charts, not to replace them. Only official government charts and notices to mariners contain all of the current information needed for the safety of navigation, and the captain is responsible for their prudent use.*

**WARNING!** *Disassembly and repair of this electronic unit should only be performed by authorized service personnel. Any modification of the serial number or attempt to repair the original equipment or accessories by unauthorized individuals will void the warranty.*

**WARNING!** *This product contains chemicals known to the State of California to cause cancer and/or reproductive harm.*

**WARNING!** *Do not travel at high speed with the unit cover installed. Remove the unit cover before traveling at speeds above 20 mph.*

**WARNING!** *Humminbird® is not responsible for the loss of data files (waypoints, routes, tracks, groups, recordings, etc.) that may occur due to direct or indirect damage to the unit's hardware or software. It is important to back up your control head's data files periodically. Data files should also be saved to your PC before restoring the unit's defaults or updating the software. See the following sections of your Humminbird® manual: SD Card Slot. Also, contact our Customer Resource Center with any questions.*

**NOTE:** Some features discussed in this manual require a separate purchase, and some features are only available on international models. Every effort has been made to clearly identify those features. Please read the manual carefully in order to understand the full capabilities of your model.

**NOTE:** To purchase accessories for your control head, visit our Web site at [humminbird.com](http://humminbird.com) or contact our Customer Resource Center at **1-800-633-1468**.

**NOTE:** The procedures and features described in this manual are subject to change without notice. This manual was written in English and may have been translated to another language. Humminbird® is not responsible for incorrect translations or discrepancies between documents.

**NOTE:** The illustrations in this manual may not look the same as your product, but your unit will function in the same way.

**ROHS STATEMENT:** Product designed and intended as a fixed installation or part of a system in a vessel may be considered beyond the scope of Directive 2002/95/EC of the European Parliament and of the Council of 27 January 2003 on the restriction of the use of certain hazardous substances in electrical and electronic equipment.

**ATTENTION INTERNATIONAL CUSTOMERS:** Products sold in the U.S. are not intended for use in the international market. Humminbird® international units provide international features and are designed to meet country and regional regulations. Languages, maps, time zones, units of measurement, and warranty are examples of features that are customized for Humminbird® international units purchased through our authorized international distributors.

To obtain a list of authorized international distributors, please visit our Web site at [humminbird.com](http://humminbird.com) or contact our Customer Resource Center at **(334) 687-6613**.

500 Series™, Down Imaging™, Fish ID+™, Humminbird®, HumminbirdPC™, RTS™, RTS Window™, Structure ID®, SwitchFire™, WhiteLine™, UniMap™, and X-Press™ Menu are trademarked by or registered trademarks of Humminbird®.

Baekmuk Batang, Baekmuk Dotum, Baekmuk Gulim, and Baekmuk Headline are registered trademarks owned by Kim Jeong-Hwan.

Navionics® Gold, HotMaps®, and HotMaps® Premium are registered trademarks of Navionics®.

© 2012 Johnson Outdoors Marine Electronics, Inc. All rights reserved.

# Table of Contents

---

<b>Power On</b>	<b>1</b>
<b>How Sonar Works</b>	<b>2</b>
Down Imaging™ Sonar.....	4
<b>How GPS Works</b>	<b>5</b>
<b>What's on the Sonar Display</b>	<b>6</b>
Understanding the Sonar Display .....	8
Real Time Sonar (RTS™) Window .....	8
SwitchFire™ .....	9
Freeze Frame and Active Cursor.....	9
Instant Image Update .....	9
Sonar Returns and Bottom View .....	10
<b>What's on the Down Imaging™ Display</b>	<b>12</b>
Understanding the Down Imaging™ Display .....	14
Interpreting the Display .....	14
Down Imaging™ Sensitivity .....	15
Freeze Frame and Active Cursor.....	15
<b>Views</b>	<b>16</b>
Sonar View .....	18
Sonar Zoom View .....	19
Split Sonar View .....	20
Down Imaging™ View .....	21
Down/Sonar Combo View .....	22
Big Digits View .....	23
Bird's Eye View .....	24
Chart View .....	25
Combo View .....	27
Chart/Down Combo View .....	28
View Orientation .....	29
Viewing Cartography.....	30



# Table of Contents

---

<b>Introduction to Navigation</b>	<b>32</b>
Waypoints, Routes, and Tracks .....	32
Open the Waypoint Management Dialog Box .....	34
What's on the Waypoint Management Dialog Box .....	35
Save, Create, or Delete a Waypoint.....	37
Navigate to a Waypoint or Position .....	38
Add a Waypoint Target or Trolling Grid .....	39
Routes .....	40
Tracks.....	42
Edit your Waypoints, Routes, Tracks, and Groups .....	43
<b>What's on the 500 Series™ Control Head</b>	<b>45</b>
<b>Key Functions</b>	<b>46</b>
POWER/LIGHT Key .....	46
VIEW Key.....	47
INFO Key .....	47
MENU Key.....	47
4-WAY Cursor Control Key .....	48
MARK Key .....	48
GOTO Key.....	49
ZOOM (+/-) Key.....	49
EXIT Key.....	49
<b>SD Memory Card Slot</b>	<b>50</b>
Add Maps to Your Fishfinder .....	51
Import Navigation Data .....	51
Export Navigation Data.....	52
<b>The Menu System</b>	<b>54</b>
<b>Start-Up Options Menu</b>	<b>55</b>
Normal.....	55
Simulator .....	56

# Table of Contents

---

System Status .....	56
Self Test .....	57
Accessory Test.....	57
GPS Diagnostic View .....	58
<b>X-Press™ Menu</b> .....	<b>59</b>
<b>Main Menu</b> .....	<b>60</b>
Quick Tips for the Main Menu .....	61
Note for all Menu Settings .....	61
User Mode (Normal or Advanced) .....	62
<b>Sonar X-Press™ Menu</b> ( <i>Sonar Views only</i> ) .....	<b>64</b>
Cancel Navigation ( <i>only when navigating</i> ) .....	65
Sensitivity .....	65
Upper Range ( <i>Advanced: Sonar and Big Digits Views only</i> ) .....	66
Lower Range .....	66
Chart Speed.....	67
Bottom View .....	67
Bottom Lock ( <i>Sonar Zoom View only</i> ) .....	67
Bottom Range ( <i>Sonar Zoom View only when Bottom Lock is On</i> ) .....	68
<b>Down Imaging™ X-Press™ Menu</b> ( <i>Down Imaging™ Views only</i> ) .....	<b>69</b>
Cancel Navigation ( <i>only when navigating</i> ) .....	70
Imaging Sensitivity .....	70
DI Enhance .....	70
Upper Range ( <i>Advanced</i> ) .....	71
Lower Range .....	72
Chart Speed.....	72
Imaging Palette .....	72
<b>Navigation X-Press™ Menu</b> ( <i>Navigation Views only</i> ) .....	<b>73</b>
Cancel Navigation ( <i>only when Navigating</i> ).....	74
Skip Next Waypoint ( <i>only when Navigating</i> ) .....	74
Waypoint [Name] ( <i>Only with an active cursor on a waypoint</i> ) .....	74

# Table of Contents

---

Cursor To Waypoint ( <i>Chart or Combo View only</i> ) .....	75
Chart Declutter .....	75
Save Current Track .....	75
Clear Current Track .....	75
Save Current Route ( <i>only when Navigating</i> ) .....	75
Sonar Window ( <i>Combo View only</i> ) .....	76
Reset XTE ( <i>only when Navigating</i> ) .....	76
Remove Target ( <i>only if Target is Active</i> ) .....	76
Remove Grid ( <i>only if Grid is Active</i> ) .....	76
Waypoint [Name] ( <i>Most recently-created waypoint</i> ) .....	77

## **Alarms Menu Tab** **78**

---

Depth Alarm .....	79
Fish ID Alarm.....	79
Low Battery Alarm .....	79
Temp. Alarm .....	80
Off Course Alarm .....	80
Arrival Alarm .....	81
Drift Alarm.....	81
Alarm Tone .....	81
Timer Setup.....	82
Start Timer.....	82
Stop Timer ( <i>with the Timer running</i> ) .....	82

## **Sonar Menu Tab** **83**

---

Beam Select .....	84
Imaging Frequency ( <i>Down Imaging™ Views only</i> ) .....	85
Surface Clutter .....	86
SwitchFire™ .....	86
Fish ID+™ .....	87
Fish ID Sensitivity .....	88
Real Time Sonar (RTS™) Window .....	88

# Table of Contents

---

Zoom Width.....	88
455 kHz Sensitivity ( <i>Advanced, Down Imaging™ only</i> ) .....	89
Depth Lines ( <i>Advanced</i> ) .....	89
Noise Filter ( <i>Advanced</i> ) .....	89
Max Depth ( <i>Advanced</i> ) .....	90
Water Type ( <i>Advanced</i> ) .....	90
Digital Depth Source ( <i>Advanced, optional-purchase transducers only</i> ) .....	91
DI Pings ( <i>Advanced, Down Imaging™ View and Chart/Down Combo View only</i> ) .....	91
Imaging Palette ( <i>Down Imaging™ Views only</i> ) .....	92

## **Navigation Menu Tab** **93**

---

Current Track .....	94
Waypoints, Routes, Tracks ( <i>Waypoint Management Dialog Box</i> ) .....	94
Waypoint Settings.....	95
Saved Tracks Defaults.....	95
Chart Orientation.....	96
Casting Rings ( <i>Advanced</i> ) .....	96
Lat/Lon Grid.....	96
Chart Select ( <i>SD card in slot</i> ) .....	96
North Reference .....	96
Waypoint Proximity Flags ( <i>Advanced</i> ) .....	97
Waypoint Decluttering ( <i>Advanced</i> ).....	97
Grid Rotation .....	98
Trackpoint Interval.....	98
Track Min Distance ( <i>Advanced</i> ) .....	98
Map Datum ( <i>Advanced</i> ) .....	99
Set Simulation Position ( <i>Advanced</i> ) .....	99
Set Map Offset ( <i>Advanced</i> ) .....	99
Clear Map Offset ( <i>Advanced</i> ) .....	100
North-Up Indicator .....	100
Course Projection Line .....	100
Chart Detail Level .....	101

# Table of Contents

---

Map Borders .....	102
Spot Soundings.....	103
Auto Zoom ( <i>Advanced</i> ) .....	103
Auto Range ( <i>Advanced</i> ) .....	103
Vessel Offset .....	104
Offset Speed ( <i>with Vessel Offset turned on</i> ) .....	104
<b>Setup Menu Tab</b> .....	<b>105</b>
Units - Depth.....	106
Units - Temp ( <i>International only</i> ) .....	106
Units - Distance .....	106
Units - Speed .....	106
User Mode .....	106
Language ( <i>International only</i> ).....	107
Triplog Reset .....	107
Restore Defaults .....	107
Format Nav Directories.....	107
Select Readouts ( <i>Advanced, Sonar View and Down Imaging™ View only</i> ) .....	108
Depth Offset ( <i>Advanced</i> ).....	109
Temp. Offset ( <i>Advanced, with Temp/Speed only</i> ) .....	109
Speed Calibration ( <i>Advanced, with Temp/Speed only</i> ) .....	109
Local Time Zone ( <i>Advanced</i> ).....	109
Daylight Saving Time ( <i>Advanced</i> ).....	110
Position Format ( <i>Advanced</i> ) .....	110
Time Format ( <i>Advanced, International only</i> ) .....	110
Date Format ( <i>Advanced, International only</i> ).....	110
Digits Format ( <i>Advanced</i> ) .....	111
NMEA 0183 Output ( <i>Advanced</i> ).....	111
Sonar .....	112
Demonstration.....	112
Sound Control .....	112

# Table of Contents

---

<b>Views Menu Tab</b>	<b>113</b>
<b>Maintenance</b>	<b>114</b>
<b>Troubleshooting</b>	<b>116</b>
Fishfinder Doesn't Power Up .....	116
Fishfinder Defaults to Simulator with a Transducer Attached .....	116
Display Problems .....	117
Finding the Cause of Noise .....	118
<b>Specifications</b>	<b>119</b>
<b>Glossary</b>	<b>122</b>
<b>Contact Humminbird®</b>	<b>130</b>

***NOTE:** Entries in this Table of Contents which list (International Only) are only available on products sold outside of the U.S. by our authorized international distributors. To obtain a list of authorized international distributors, please visit our Web site at [humminbird.com](http://humminbird.com) or contact our Customer Resource Center at (334) 687-6613.*

***NOTE:** Entries in this Table of Contents which list (with Temp/Speed only) require the purchase of separate accessories. You can visit our Web site at [humminbird.com](http://humminbird.com) to order these accessories online or contact our Customer Resource Center at 1-800-633-1468.*

***NOTE:** Some features discussed in this manual require a separate purchase, and some features are only available on international models. Every effort has been made to clearly identify those features. Please read the manual carefully in order to understand the full capabilities of your model.*

## Power On

---

Follow the instructions below to power on your Humminbird® control head.

Title Screen



1. Press the  POWER/LIGHT key.
2. When the Title screen is displayed, press the MENU key to access the Start-Up Options Menu.
3. If a functioning transducer is connected, Normal operation will be selected automatically, and your Fishfinder can be used on the water. See *Start-Up Options Menu* for more information.
  - If a transducer is not connected and you wait too long to select a Start-Up Option, the system will default to whichever menu is already highlighted.
  - You can also select **Simulator** to learn how to use your control head and save settings in advance for later use.
4. **Quick Setup:** If this is the first time the unit has been powered on (after installation or after restoring defaults), the Quick Setup dialog box will display on the screen. Use the 4-WAY Cursor Control key to set the Language, Water Type, and Max Depth. Press the EXIT key to close the dialog box.

*NOTE: The Quick Setup settings can be changed at any time. See each menu option in **The Menu System** for details.*

## How Sonar Works

Sonar technology is based on sound waves. The 500 Series™ Fishfinder uses sonar to locate and define structure, bottom contour and composition, as well as depth directly below the transducer.

Your 500 Series™ Fishfinder sends a sound wave signal and determines distance by measuring the time between the transmission of the sound wave and when the sound wave is reflected off of an object; it then uses the reflected signal to interpret location, size, and composition of an object.

Sonar is very fast. A sound wave can travel from the surface to a depth of 240 ft (70 m) and back again in less than 1/4 of a second. It is unlikely that your boat can “outrun” this sonar signal.

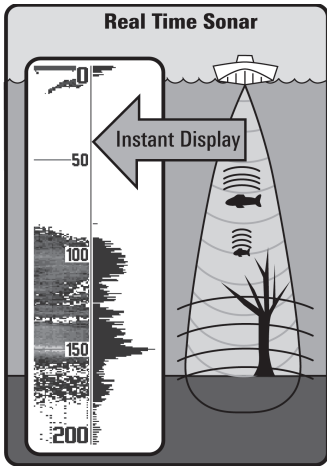

SONAR is an acronym for SOund and NAvigation Ranging. Sonar uses precision sound pulses or “pings” which are emitted into the water in a teardrop-shaped beam.

The sound pulses “echo” back from objects in the water such as the bottom, fish, and other submerged objects. The returned echoes are displayed on the LCD screen. Each time a new echo is received, the old echoes are moved across the LCD, creating a scrolling effect.



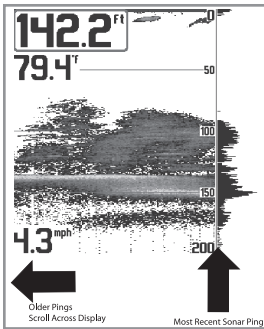

When all the echoes are viewed side by side, an easy to interpret “graph” of the bottom, fish, and structure appears.

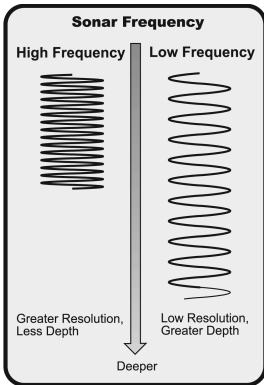

The sound pulses are transmitted at various frequencies depending on the application. Very high frequencies (455 kHz) are used for greatest definition but the operating depth is limited. High frequencies (200 kHz) are commonly used on consumer sonar and provide a good balance between depth performance and resolution. Low frequencies (83 kHz) are typically used to achieve greater depth capability.

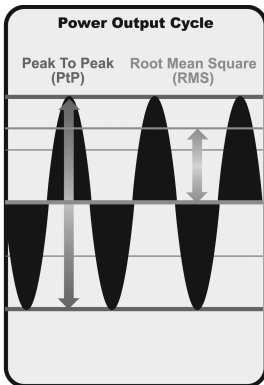

The power output is the amount of energy generated by the sonar transmitter. It is commonly measured using two methods:

- Root Mean Square (RMS) measures power output over the entire transmit cycle.
- Peak to Peak measures power output at the highest points.

The benefits of increased power output are the ability to detect smaller targets at greater distances, ability to overcome noise, better high speed performance and enhanced depth capability.

## Down Imaging™ Sonar

Your **Fishfinder** uses Down Imaging™ technology. The Down Imaging™ transducer scans the water with razor-thin, high-definition beams. The beams are wide (side to side) but very thin front to back.

The Down Imaging™ beams can be operated at two frequencies: 455 kHz (75°) or 800 kHz (45°). Select 455 kHz for the best overall image quality and depth. Select 800 kHz for the sharpest image. See *Down Imaging™ X-Press™ Menu: Imaging Frequency* for more information.

The transducer also uses conical beams to provide data in traditional 2D format (see *What's on the Sonar Display*). Select 455 kHz for a narrowly focused 16° center beam, or select 200 kHz for a wider 25° beam (see *Sonar Menu Tab: Beam Select*).

Depth capability is affected by such factors as boat speed, wave action, bottom hardness, water conditions, and transducer installation.

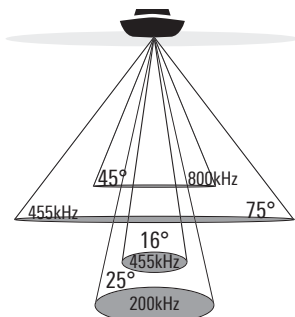

❖ 75 Degree Total Coverage

❖ Bottom Coverage = 1 x Depth

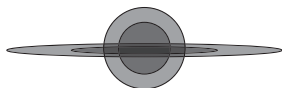

## How GPS Works

---

Your 500 Series™ Fishfinder also supports GPS (Global Positioning System) and chartplotting. It uses GPS and sonar to determine your position, display it on a grid, and provide detailed underwater information.



GPS uses a constellation of satellites that continually send radio signals to the earth. The GPS receiver on your boat receives signals from satellites that are visible to it. Based on time differences between each received signal, the GPS receiver determines its distance to each satellite. With distances known, the GPS receiver mathematically triangulates its own position. With 5 updates per second, the GPS receiver then calculates its velocity and bearing.

GPS was originally intended for military use; however, civilians may also take advantage of its highly accurate position capabilities, typically within +/- 10 meters, depending on conditions. This means that 95% of the time, the GPS receiver will read a location within 10 meters of your actual position. Your GPS Receiver also uses information from WAAS (the Wide Area Augmentation System), EGNOS (the European Geostationary Navigation Overlay Service), and MSAS (the MTSAT Satellite Augmentation System) satellites if they are available in your area.

The following GPS functionality is currently supported by the 500 Series™ Fishfinder when it is connected to the included GPS receiver:

- View current position
- View current track (breadcrumb trail)
- View precision speed and heading from your GPS receiver
- Save tracks, waypoints, and routes
- Travel a route and navigate from one waypoint to the next.

See *Chart View* and *SD Memory Card Slot: Add Maps to Your Fishfinder* for more information.

# What's on the Sonar Display

The 500 Series™ Fishfinder can display a variety of useful information about

**Depth** - Water depth; can be set to alarm when the water becomes too shallow.

**Speed** - If a Temp/Speed accessory or GPS Receiver is attached, the Fishfinder can display the speed of the boat and can keep a Triplog of nautical or statute miles traveled.

**Temperature** - Water surface temperature.

**Timer** - Elapsed time with Temp/Speed Accessory or GPS Receiver.

**Distance** - Distance traveled with Temp/Speed Accessory or GPS Receiver.

**Average Speed** - Average speed reading with Temp/Speed Accessory or GPS Receiver.

**Second Sonar Return** - When the sonar signal bounces between the bottom and the surface of the water and back again. Use the appearance of the second return to determine bottom hardness. Hard bottoms will show a strong second return, while soft bottoms will show a very weak one or none at all.

**Cursor Dialog Box** - Indicates cursor depth on the display and the depth of the bottom directly below the cursor. The Latitude and Longitude of the cursor position, the distance to travel to the cursor position, and the bearing to the cursor position are shown with a GPS receiver. A waypoint can be marked at the cursor position for later retrieval and use with a GPS receiver.

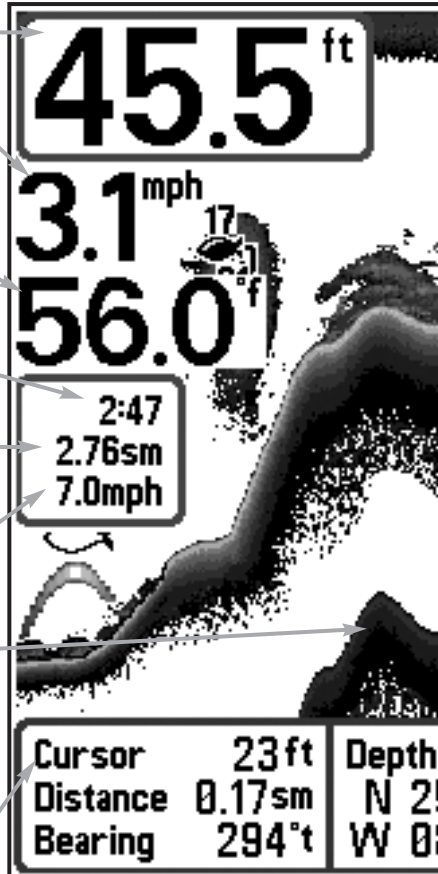

**NOTE:** Entries in this view that list (with Temp/Speed or GPS Receiver) are available if either the information from the GPS receiver will be displayed on the view.

the area under your boat, including the following items:

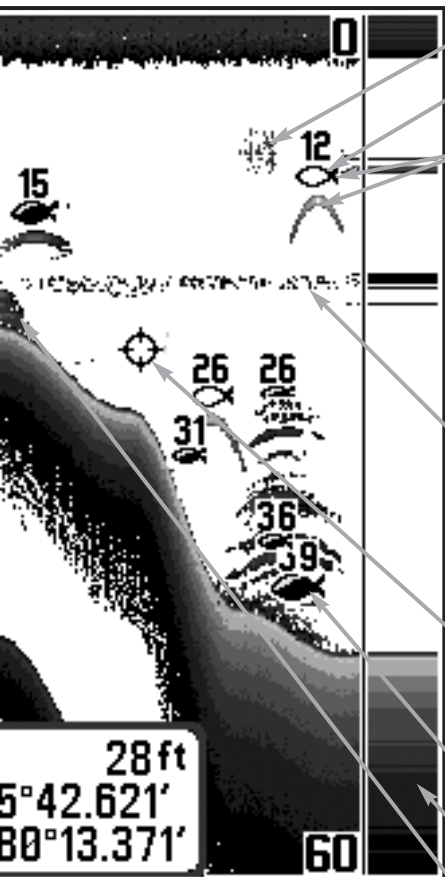

**Bait Ball**

**Hollow Fish Symbol** (See *Fish ID+*<sup>™</sup>)

**Fish** - The Fishfinder displays fish as arches and/or fish icons, and can be set to alarm when a fish of a certain size is detected. When a target is detected, a Fish ID+<sup>™</sup> symbol appears on the display with the depth displayed above it. The size of the symbol indicates the intensity of the sonar return. The unit will clearly show schools of Bait Fish as "clouds" of different shapes and sizes, depending on the number of fish and boat speed.

**Thermoclines** - Layers of water with different temperatures that appear at different depths and different times of the year. A thermocline typically appears as a continuous band of gray levels moving across the display at the same depth.

**Cursor** - Available in Freeze Frame and can be positioned in the Sonar View to provide depth of a sonar return and bottom depth below the cursor.

**Shaded Fish Symbol** (See *Fish ID+*<sup>™</sup>)

**RTS (Real Time Sonar) Window**<sup>™</sup>

**Structure** - Where fish may be hiding.

*device is connected to the 500 Series<sup>™</sup> Fishfinder. If both devices are connected, then only*

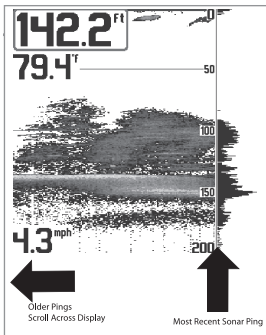

## Understanding the Sonar Display

It is important to understand the significance of the display. The display does not show a literal 3-dimensional representation of what is under the water. Each vertical band of data received by the control head and plotted on the display represents something that was detected by a sonar return at a particular time. As both the boat and the targets (fish) may be moving, the returns are only showing a particular segment of time when objects were detected, not exactly where those objects are in relation to other objects shown on the display.

The returned sonar echoes are displayed on the screen. As a new echo is received, the historical data scrolls across the screen.

## Real Time Sonar (RTS™) Window

A **Real Time Sonar (RTS™) Window** appears on the right side of the display in the Sonar View only. The RTS Window™ updates at the fastest rate possible for depth conditions and shows only the returns from the bottom, structure, and fish that are within the transducer beam. The RTS Window™ plots the depth and intensity of a sonar return (see *Sonar Menu Tab: RTS Window™*).

The **Narrow RTS Window™** indicates the sonar intensity through the use of grayscale. The grayscale used matches the Bottom View grayscale setting (Inverse, StructureID®, WhiteLine™, Bottom Black). The depth of the sonar return is indicated by the vertical placement of the return on the display depth scale.

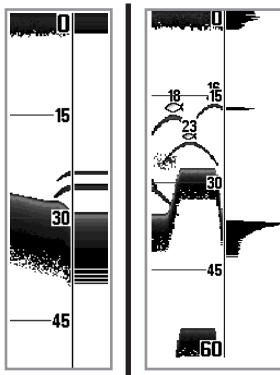

The **Wide RTS Window™** indicates the sonar intensity through the use of a bar graph. The length of the plotted return indicates whether the return is weak or strong. The depth of the sonar return is indicated by the vertical placement of the return on the display depth scale. The Wide RTS Window™ does not use grayscale.

## SwitchFire™

---

**SwitchFire™** controls how the sonar returns are displayed in the Sonar Views. SwitchFire™ settings are available in the Sonar Menu Tab.

To see the maximum sonar information available within the transducer beam so more fish arches and better jig tracking are shown, choose Max Mode.

To see less clutter and more fish size accuracy interpreted from the transducer beam, choose Clear Mode. See *Sonar Menu Tab: SwitchFire™* for more information.

## Freeze Frame and Active Cursor

---

**Freeze Frame & Active Cursor** - Press any arrow on the 4-WAY Cursor Control key, and the screen will freeze and a cursor will be displayed. Use the 4-WAY Cursor Control key to move the cursor over a sonar return, and the depth of the sonar return will be displayed at the bottom of the screen in the cursor information box.

The RTS Window™ continues to update in Freeze Frame. To return to a scrolling display and exit Freeze Frame, press the EXIT key. Freeze Frame is available in the Sonar, Split Sonar, and Sonar Zoom Views.

## Instant Image Update

---

**Instant Image Update** - You can change a variety of sonar menu settings (such as Sensitivity or Upper Range), and the adjustments will be shown instantly on the screen.

### Sonar Colors: Original Palette

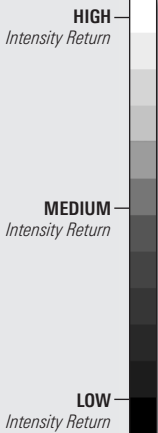

## Sonar Returns and Bottom View

As the boat moves, the unit charts the changes in depth on the display to create a profile of the **Bottom Contour**. The Sonar View displays the sonar return intensity using gray scale.

**Strong returns** often result from rocky or hard bottoms (compacted sediment, rocks, fallen trees), while **weaker returns** often result from soft bottoms (sand, mud), vegetation, and small fish.

The shades used to represent high, medium, to low intensity returns are determined by the setting you choose in the **Bottom View** menu option. See *Sonar X-Press™ Menu* to set the Bottom View.

### Sonar View:

Bottom View set to Inverse (default setting)

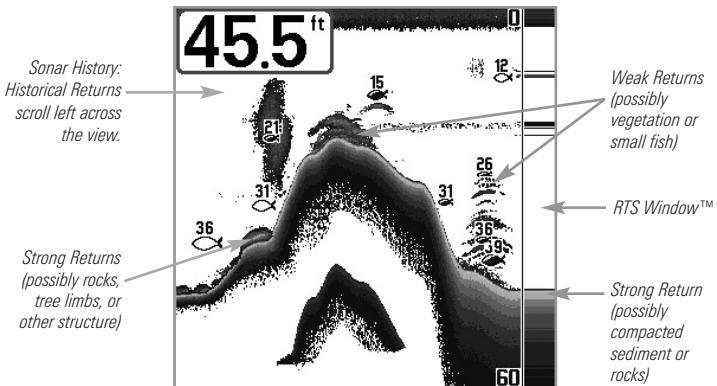



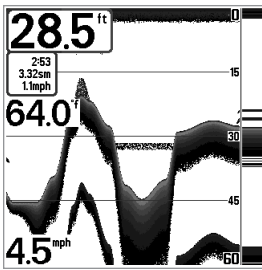

**Inverse** is a method where weak returns are shown with dark pixels and strong returns with lighter pixels. This has the benefit of ensuring that weak signals will be clearly visible on the display.

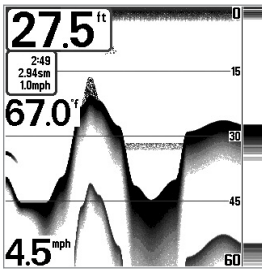

**Structure ID®** represents weak returns as light pixels and strong returns as dark pixels. This has the benefit of ensuring that strong returns will be clearly visible on the display.

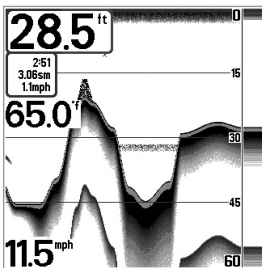

**WhiteLine™** highlights the strongest sonar returns in white resulting in a distinctive outline. This has the benefit of clearly defining the bottom on the display.

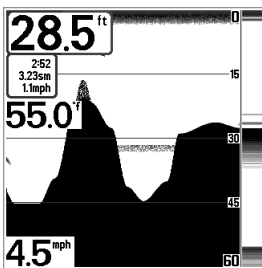

**Black (Bottom Black)** displays all pixels below the bottom contour as black, regardless of signal strength. This has the benefit of providing a high contrast between the bottom and other sonar returns on the display.

## What's on the Down Imaging™ Display

Down Imaging™ uses its unique transducer and sonar technology to provide definition profiling beams produce the detailed sonar data that you see on the can interpret the structure and bottom contour, including the following items:

**Depth** - (water depth) can be set to alarm when the water becomes too shallow.

46.6<sup>ft</sup>

**Temperature** - Water surface temperature.

76.1<sup>°F</sup>

**Topography Changes** - The light part of the display shows where the beam is hitting hard bottom or rising terrain. The dark part of the display indicates soft bottom (sand, mud) or descending terrain.

**Speed** - If a Temp/Speed accessory is connected, the Fishfinder can display the speed of the boat and can keep a Triplog of nautical or statute miles traveled.

5.6<sup>mph</sup>

*NOTE: Entries in this view that list (with Temp/Speed) are available if the accessory is connected*

information about the area directly below your boat. The razor-thin, high-display. Down Imaging™ reveals a variety of recognizable features so that you

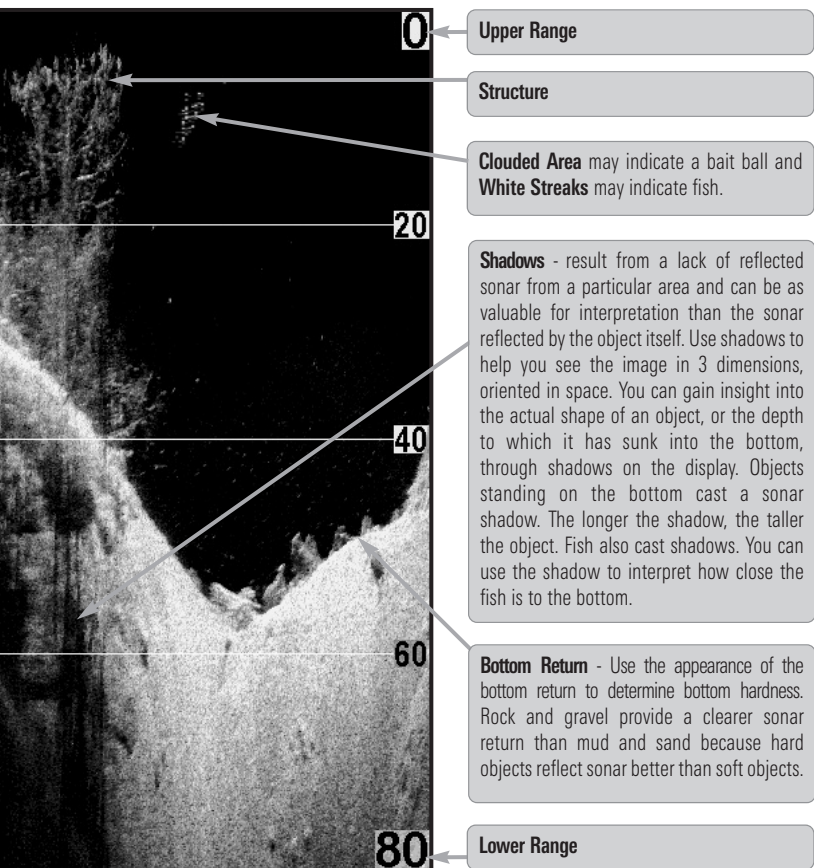

to the 500 Series™ Fishfinder.

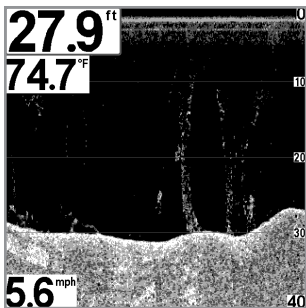

## Understanding the Down Imaging™ Display

---

The images you see on the Down Imaging™ display are produced using sonar technology. Each time the unit pings, a strip of data representing all the echoes received by the transducer are put together on the display to form the image that you see. Like traditional 2D Sonar, the sonar history scrolls left across the screen.

## Interpreting the Display

---

Down Imaging™ beams “illuminate” the bottom contour, structure, and fish. The beams are wide (side to side) but very thin front to back.

Use the light and dark parts of the display to interpret the objects under your boat as follows:

- **Dark shades** represent soft returns (mud, sand) or descending terrain.
- **Light shades** represent denser terrain (timber, rocks) or rising terrain. A very hard bottom may appear as **white** on the display.
- **White Streaks** or **Clouds** may represent fish on the display.
- **Shadows** are not caused by light but by the lack of a sonar return. Objects standing on the bottom cause a sonar shadow to appear on the display. The longer the shadow, the taller the object. Fish may also cast shadows. You can use the shadow to interpret where the fish or object is located in relation to the bottom.

## **Down Imaging™ Sensitivity**

---

Use **Imaging Sensitivity** to control how the sonar returns appear on the display. Increase the sensitivity to reveal weaker returns that may be of interest, especially in very clear water or greater depths. Decrease the Imaging Sensitivity to eliminate the clutter from the display that is sometimes present in murky or muddy water. See *Down Imaging™ X-Press™ Menu: Imaging Sensitivity* for more information.

## **Freeze Frame and Active Cursor**

---

**Freeze Frame and Active Cursor** - Press any arrow on the 4-WAY Cursor Control key, and the screen will freeze and a cursor will be displayed. Use the 4-WAY Cursor Control key to move the cursor over a sonar return, and the depth of the sonar return will be displayed in the cursor dialog box.

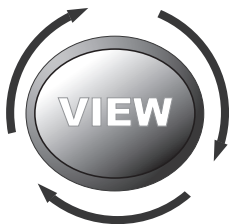

## Views

---

The sonar and navigation information from your Fishfinder is displayed on the screen in a variety of easy-to-read views. There are many views available on your Fishfinder.

- **Default View:** When you first power up the control head, Down Imaging™ View will be the default view.
- **Cycle:** When you press the VIEW key repeatedly, the display cycles through the available views on your screen. When you press the EXIT key, the display cycles through the available views in reverse order.
- **Customize:** You can display or hide any view to suit your fishing preferences. See the following pages for more information about each View.

***NOTE:** When you change any menu settings that affect the sonar, the view will update immediately. You don't have to exit the menu to apply the change to the screen.*

### To customize your view rotation:

You can choose which views are hidden or visible in your view rotation.

1. Press the MENU key twice to access the tabbed Main Menu, then press the RIGHT Cursor key until the Views tab is selected.
2. Press the UP or DOWN Cursor keys to select a View.
3. Press the LEFT or RIGHT Cursor keys to change the status of the view from Hidden to Visible or vice versa.

### To change the Digital Readouts:

Each view displays digital readout information (such as speed or time), which varies with the view selected, the accessory attached, and whether or not you are navigating. The digital readouts on the Sonar View can be customized. See *Setup Menu Tab: Select Readouts* for more information.

1. Press the MENU key twice to access the tabbed Main Menu, then press the RIGHT Cursor key until the Setup tab is selected.
2. Press the DOWN key to highlight Select Readouts, and press the RIGHT Cursor key to access the Select Readouts submenu.

**NOTE:** If the Select Readouts option does not appear under the Setup tab, change the User Mode to Advanced.

3. Press the UP or DOWN Cursor keys to select a Readout position, then press the RIGHT or LEFT Cursor keys to choose what will be displayed in that position. To hide the data window, select Off. (Course, Navigation, Off, Position, Speed, Temperature, Time+Date, Triplog, Voltage, Time)

## Sonar View

**Sonar View** presents a historical log of sonar returns. The most recent sonar returns are charted on the right side of the display. As new information is received, the historical information scrolls left across the display.

- **Upper and Lower Depth Range** numbers indicate the distance from the surface of the water to a depth range sufficient to show the bottom.
- **Depth** is automatically selected to keep the bottom visible on the display, although you can adjust it manually as well (see *Sonar X-Press™ Menu*).
- **Digital Readouts** shown on the display will change based on the Select Readouts settings or the optional-purchase accessories attached (see *Setup Menu Tab: Select Readouts*).
- **Freeze Frame** - Use the 4-WAY Cursor Control key to freeze the display and move the cursor over a sonar return. The depth of the sonar return will be displayed at the bottom of the screen in the cursor information box.

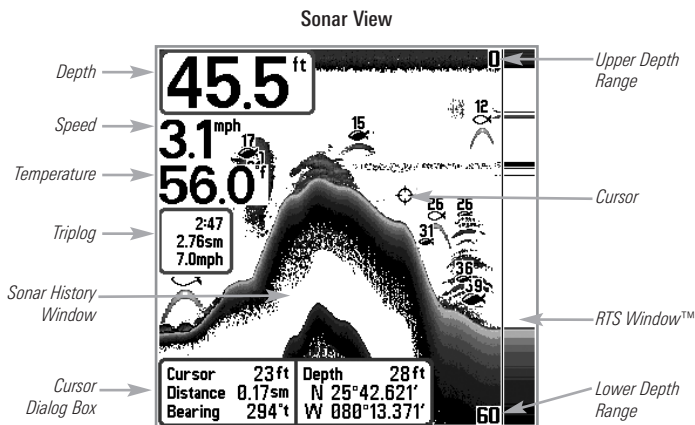

**NOTE:** If the Depth number is flashing, it means that the unit is having trouble locating the bottom. This usually happens if the water is too deep, the transducer is out of the water, the boat is moving too fast, or for any other reason that the unit can't accurately receive continuous data.



## Sonar Zoom View

**Sonar Zoom View** provides a magnified view of the bottom and structure. The Sonar Zoom View makes it easier to see separate sonar returns that would usually be displayed close together, such as those caused by fish suspended close to the bottom or within structure.

- The **Zoom Level**, or magnification, is displayed in the lower left corner of the display. Press the + or - ZOOM keys to increase or decrease the zoom level.
- The **Zoomed View** is displayed on the left side of the screen. As the depth changes, the zoomed view updates automatically.
- The **Full Range View** is displayed on the right side of the screen. The Full Range View includes the Zoom Preview Box, which shows where the zoomed view is in relation to the full range view.
- The **Upper and Lower Depth Range** numbers indicate the high and low range of the water which is being viewed.
- **Freeze Frame** - Use the 4-WAY Cursor Control key to freeze the display and move the cursor over a sonar return. The depth of the sonar return will be displayed at the bottom of the screen in the cursor information box.

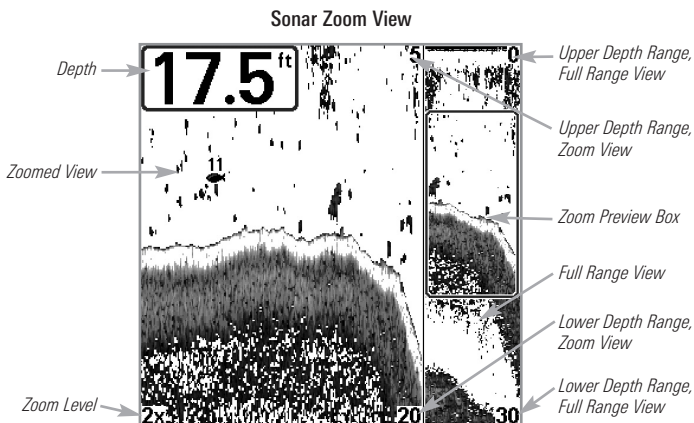

*Digital depth is displayed in the upper left hand corner. The digital readouts in the Sonar Zoom View cannot be customized; therefore, information such as water temperature and voltage are unavailable in the Sonar Zoom View.*

## Split Sonar View

**Split Sonar View** displays sonar returns from each down beam frequency on separate sides of the screen. You can use the Split Sonar View to make side by side comparisons between the sonar returns from both beams.

- **Down Imaging™ models** display sonar returns from the 455 kHz narrow beam on the left side of the screen and sonar returns from the 200 kHz wide beam on the right side of the screen.
- **Depth** is displayed in the upper left hand corner.
- The **Digital Readouts** in the Split Sonar View cannot be customized; therefore, information such as water temperature and voltage are unavailable in the Split Sonar View.
- **Freeze Frame** - Use the 4-WAY Cursor Control key to freeze the display and move the cursor over a sonar return. The depth of the sonar return will be displayed at the bottom of the screen in the cursor information box.

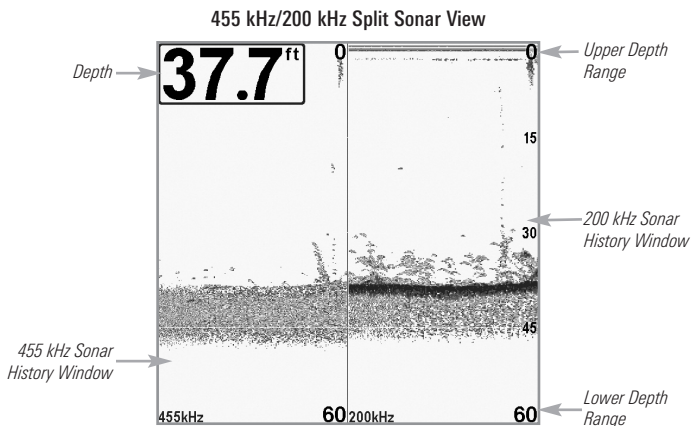

## Down Imaging™ View

**Down Imaging™ View** uses the razor-thin, high-definition profiling beams to produce the detailed sonar data that you see on the display. Sonar returns are charted on the right side of the display. As new information is received, the historical information scrolls left across the display. See *What's on the Down Imaging™ Display* for more information.

- **Down Imaging™ X-Press™ Menu:** Press the MENU key once to access the Down Imaging™ X-Press™ Menu. You can set the sensitivity of the sonar, the chart scrolling speed, the display palette, and the Upper Range and Lower Range (see *Down Imaging™ X-Press™ Menu*).
- **Freeze Frame:** Press any arrow on the 4-WAY Cursor Control key and the Down Imaging™ View will freeze and a cursor will appear on the screen. Use the 4-WAY Cursor Control key to move the cursor over a sonar return, and observe the following:
  - The **depth of the sonar return** at the cursor location will be displayed in the cursor information box.
  - **Zoom+:** Press the ZOOM+ key, and a zoom box will appear and magnify the area you choose, providing more detail in the individual sonar returns. The zoom scale will increase or decrease as you press + or – repeatedly. Press EXIT to remove the zoom box and return to Down Imaging™ View.

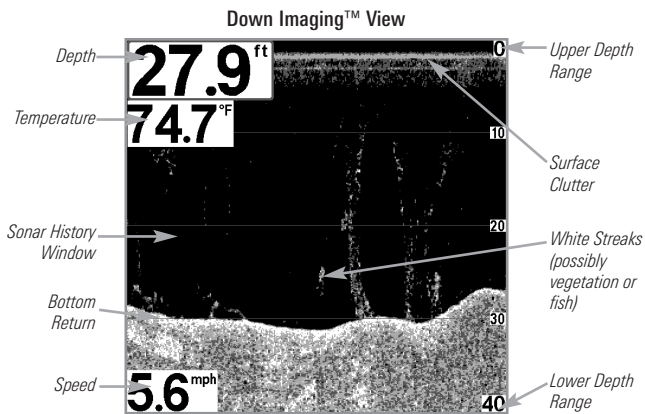

**NOTE:** See *What's on the Down Imaging™ Display* and *Down Imaging™ X-Press™ Menu* for more information.

## Down/Sonar Combo View

**Down/Sonar Combo View** shows traditional Sonar information on the top and Down Imaging™ sonar information on the bottom of the view.

- **X-Press™ Menu:** Press the MENU key once to access the Down Imaging™ X-Press™ Menu. You can set the sensitivity of the sonar, the chart scrolling speed, and the display color palette (see *Down Imaging™ X-Press™ Menu* and *Sonar X-Press™ Menu*).
- **Freeze Frame:** Press any arrow on the 4-WAY Cursor Control key and the view will freeze and a cursor will appear on both views on the screen. Use the 4-WAY Cursor Control key to move the cursor over a sonar return, and the depth of the sonar return will be displayed in the cursor dialog box.

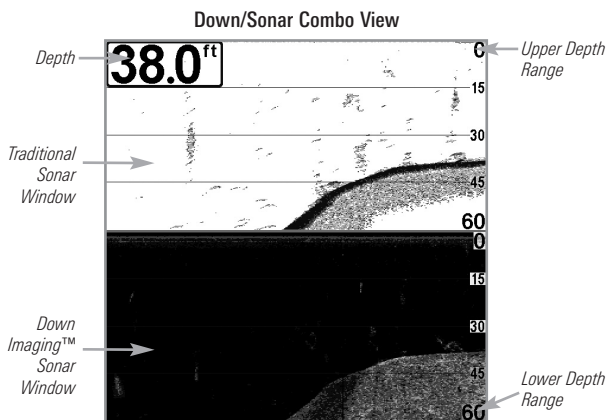

## Big Digits View

**Big Digits View** provides digital data in a large, easy-to-see format.

- **Digital Readouts:** Depth is always displayed. Readouts for temperature, speed, and Triplog information are displayed automatically if the appropriate accessory is connected to the Fishfinder.

*NOTE: The digital readouts in the Big Digits View cannot be customized.*

- The **Triplog** shows distance traveled, average speed, and time elapsed since the Triplog was last reset.

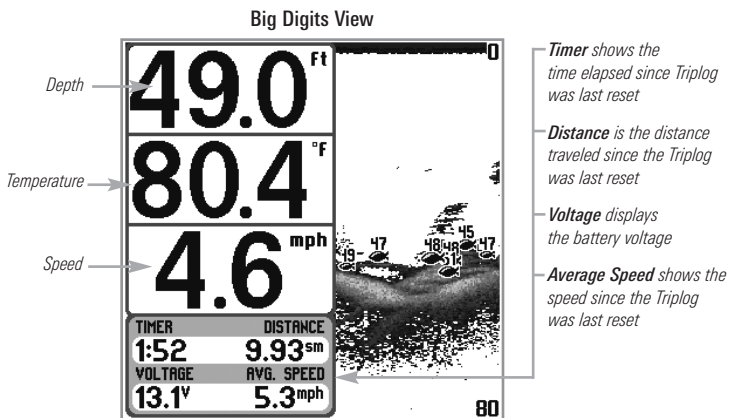

## Bird's Eye View

**Bird's Eye View** shows a 3D perspective view of the track and the chart's land contour from a point above and behind the boat (the eye point). As the boat turns, the eye point moves to follow the boat.

- **To shift the eye point position** so that you can look off to the sides, or even behind the boat: Press the RIGHT or LEFT Cursor keys to turn the eye point right or left. Press the UP Cursor key to move the eye point forward, and press the DOWN Cursor key to move the eye point backward.
- Press the EXIT key to move the eye point back to its original position behind and above the boat.

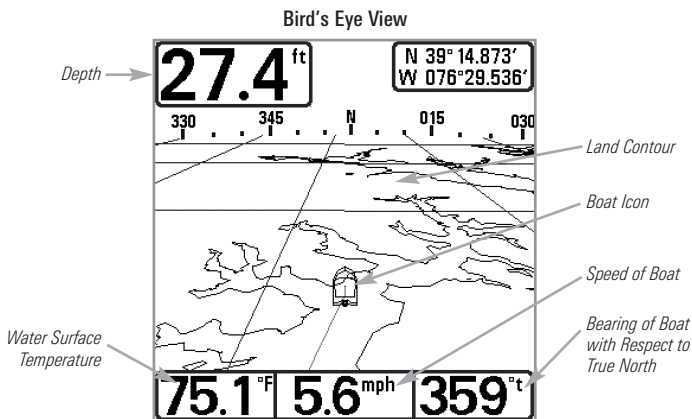

## Chart View

**Chart View** shows cartography from the built-in UniMap™ or an optional SD map for the area surrounding your current position. The current track (also known as the position history or breadcrumb trail) showing where the boat has been, along with saved tracks, waypoints, and the current route (when navigating), are overlaid on the chart.

- **Shift/Pan:** Use the 4-WAY Cursor Control key to shift/pan the chart to another area.
- **Zoom:** Press the ZOOM (+/-) keys to zoom in and out.
- **Info:** Press the INFO key to get information on the chart objects near the cursor.

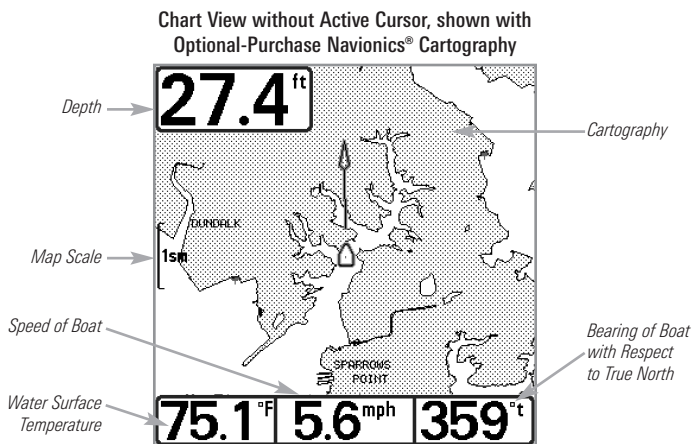
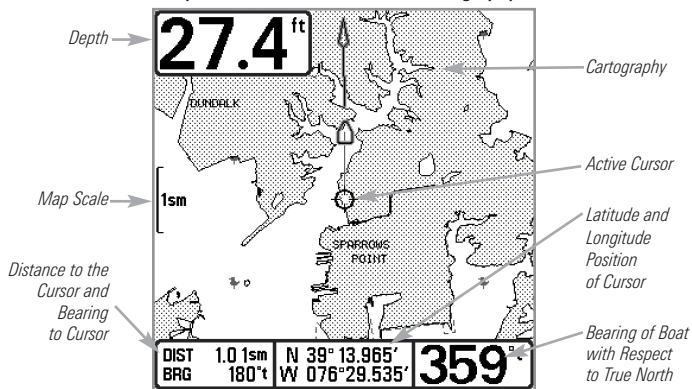

Chart View with Active Cursor, shown with  
Optional-Purchase Navionics® Cartography





## Combo View

**Combo View** is displayed as a split screen, with Chart View on the left and Sonar View on the right side of the screen.

- **X-Press™ Menu:** Press the MENU key once to access the X-Press™ Menu for this combo view. See *Navigation X-Press™ Menu* for more information about the menu options.
- **Chart Window:** Use the 4-WAY Cursor Control key to shift/pan the chart to another area. You can mark waypoints, start navigation, review position information, or magnify the view. See *Chart View* and *Introduction to Navigation* for more information.
- **Sonar Window:** To change the width of the Sonar Window, press the MENU key once and select Sonar Window from the X-Press™ Menu. Press the RIGHT or LEFT Cursor keys to select a setting.

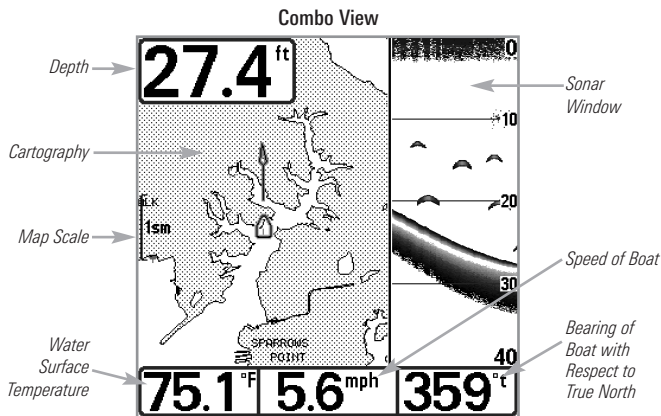

## Chart/Down Combo View

**Chart/Down Combo View** is displayed as a split screen with Chart View on the left and Down Imaging™ sonar information on the right side of the view.

- **X-Press™ Menu:** Press the MENU key once to access the X-Press™ Menu for this combo view. See *Navigation X-Press™ Menu* for more information about the menu options.
- **Chart Window:** Use the 4-WAY Cursor Control key to shift/pan the chart to another area. You can mark waypoints, start navigation, review position information, or magnify the view. See *Chart View* and *Introduction to Navigation* for more information.
- **Down Imaging™ Window:** To change the width of the Down Imaging™ Window, press the MENU key once and select Sonar Window from the X-Press™ Menu. Press the RIGHT or LEFT Cursor keys to select a setting.

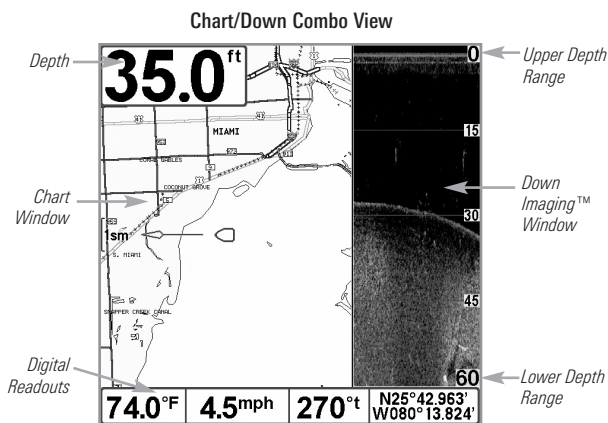

## View Orientation

---

Both Chart and Combo Views allow you to choose the orientation of the view (see *Navigation Menu Tab: Chart Orientation*). In each orientation, the view pans automatically so that the boat is always centered on the display. To see more of the view when the boat is traveling at the speed you set, see *Navigation Menu Tab: Vessel Offset* and *Offset Speed*.

- **North-Up:** True North is shown at the top of the display. Objects located to the north of the boat are drawn above the boat.
- **Heading-Up:** The boat's current heading points up, and the chart rotates around the vessel so that the vessel always points up on the view.
- **Course-Up:** During navigation, the projected course is shown at the top of the view. Objects ahead of the boat are drawn above the boat. When the boat is not navigating, the course-up reference is provided by the COG (course over ground) calculation. Also, to display the north icon on the view, see *Navigation Menu Tab: North-Up Indicator*.

**North-Up Icon:** If it is turned on, the North-Up Icon displays the direction of True North. It also displays the Chart Orientation, and the icon will change as the orientation and the data source change (see *Navigation Menu Tab: North-Up Indicator*).



**When the boat is stationary,** it is drawn as a circle.



**When the boat is in motion,** it takes on a boat shape, pointed in the direction of motion (always Up in the Course-Up orientation).

## Viewing Cartography

In the Chart or Combo Views there are several cartography-related functions that you can access using various keys.

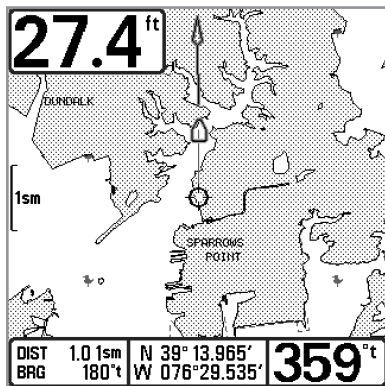

Chart View with Cursor Present, shown with Optional-Purchase Navionics® Cartography

**Panning:** Use the 4-WAY Cursor Control key to move the chart around on the display in the direction of the key being pressed. When you do this, a bull's eye cursor is drawn at the center of the screen and is linked to the boat by a gray line, even if the boat is off the screen. At the same time, the temperature and speed boxes in the lower left corner are replaced with the distance and bearing from the boat to the cursor position and the latitude/longitude coordinates of the cursor.

**Zooming:** Press the Plus (+) key to Zoom In and the Minus (–) key to Zoom Out to see the cartography at different magnification levels. The zoom level is indicated on the left side of the display. If you zoom in beyond the available chart data, the display will go into Overzoom mode whereby the last available chart data is amplified to reflect the level selected. If you zoom in so far that no cartography is available, a lat/long grid will be drawn instead. Zooming is also influenced by the Auto Zoom and Auto Range settings. See *Navigation Menu Tab: Auto Zoom* and *Auto Range* for more information.

**Decluttered Waypoints:** When two or more waypoints overlap, or are displayed close together on a chart view, the screen will automatically declutter—waypoint names will shorten and the waypoint icons will change into small gray icons.

To view a Decluttered Waypoint at full size, use the 4-WAY Cursor Control key to move the cursor onto a decluttered waypoint icon. When the cursor snaps onto the icon, the full-size waypoint name and icon will be displayed. You can also press the + ZOOM key until you can see the individual waypoints on the screen.

**Chart Info:** Press the CHECK/INFO key to get detailed information about the chart. If the cursor is active, you will see information about the chart objects located near the cursor.

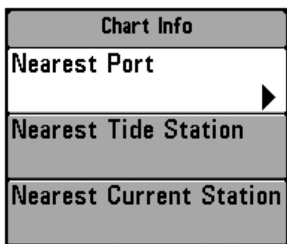

If the cursor is not active, the Chart Info submenu will appear. Use the 4-WAY Cursor Control key to select the nearest port, the nearest tide station, or the nearest current station and see information about any of these objects.

*NOTE: The built-in UniMap™ does not contain any Port, Tide, or Current information. This information is only available from optional-purchase SD cards.*

**Nearest Port:** The position and services information for the nearest port to your present position will be displayed. Press the EXIT key to remove the information box and the cursor bull's eye will be centered over the port position. The cursor information boxes at the bottom of the display will indicate the distance and bearing to the port from your present position.

**Nearest Tide Station:** Tide information for the nearest tide station to your present position will be displayed. This includes the position of the station and the times of the high and low tides for today's date. A tide graph is also displayed showing the rise and fall of the tides for the 24 hour time period encompassing the date. You can change the date to look at tide information before or after the date displayed by pressing the LEFT or RIGHT Cursor key respectively. Press the EXIT key to remove the information box, and the cursor bull's eye will be centered over the tide station position. The cursor information boxes at the bottom of the display indicate the distance and bearing to the tide station from your present position.

**Nearest Current Station:** Current information for the nearest current station to your present position will be displayed. This includes the position of the station and the current changes for today. Two graphs are also presented that show the time, direction, and flow speed of the current changes for the 24 hour time period of today's date. You can change the date to look at current information before or after the date displayed by pressing the LEFT or RIGHT Cursor key respectively. Press the EXIT key to remove the information box, and the cursor bull's eye will be centered over the current station position. The cursor

information boxes at the bottom of the display will indicate the distance and bearing to the current station from your present position.

## Introduction to Navigation

Your Fishfinder allows you to mark waypoints and start navigation with the control head keys or the Navigation X-Press™ Menu.

You can also use the Waypoint Management dialog box to create new waypoints and routes from scratch. You can edit your navigation data and organize it too. This section will get you started. See your Humminbird® Waypoint Management Guide for complete details.

## Waypoints, Routes, and Tracks

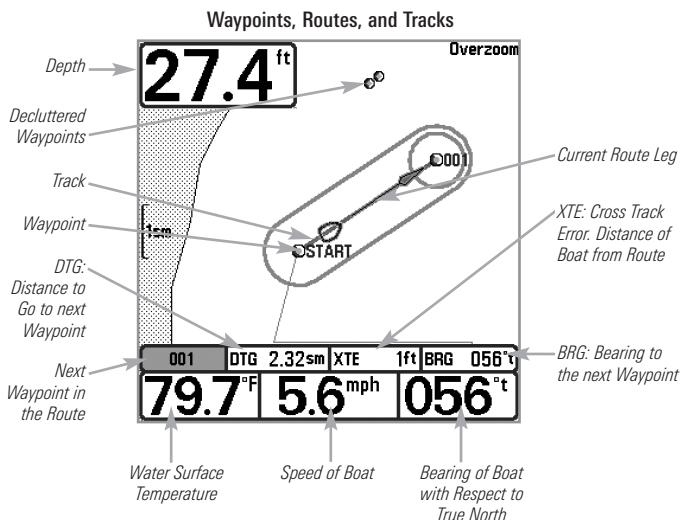

**Waypoints** are stored positions that allow you to mark areas of interest or navigation points. Your Fishfinder can store up to 2,750 waypoints.

**Routes** link two or more waypoints together to create a path for navigation and are used in trip planning. You can link individual waypoints together by using the GOTO key. Your Fishfinder can store up to 45 routes that can each contain up to 50 waypoints.

A route represents your intended navigation and shows the shortest path from each waypoint to the next. As you travel a route, staying on the route line is the most efficient way to get to your destination, although you should always look out for obstacles not shown on the chart. A **Route Leg** is the path between each waypoint in a route.

**Tracks** consist of detailed position history and are displayed as a breadcrumb trail of trackpoints. The Current Track shows the position history since the unit was powered up. You can clear the Current Track or save it at any time. Your Fishfinder can store up to 50 saved tracks, each containing 20,000 trackpoints. The current track represents your actual path so far.

***NOTE:** The maximum number of waypoints and routes may vary due to the setup of your Waypoint Management directory. Groups and sub-groups also use storage, and the storage limit is influenced by the complexity of your Waypoint Management directory.*

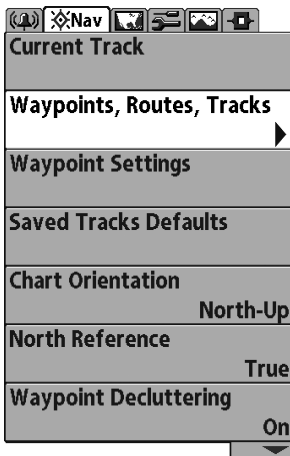

Opening the Waypoint Management Dialog Box

## Open the Waypoint Management Dialog Box

---

The **Waypoint Management dialog box** allows you to organize your waypoints, routes, and tracks on your Humminbird® control head.

### Open the Waypoint Management Dialog Box

1. Press the MENU key twice to open the Main Menu.
2. Press the RIGHT Cursor key until the Navigation Menu Tab is selected.
3. Press the DOWN Cursor key to choose Waypoints, Routes, Tracks. Press the RIGHT Cursor key to open the Waypoint Management dialog box.



## What's on the Waypoint Management Dialog Box

Use the **Waypoint Management** dialog box to manage your waypoints, routes, and tracks.

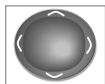
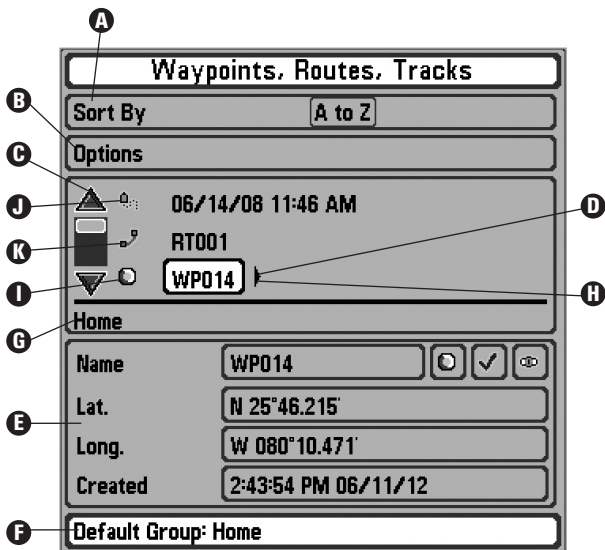

Use the 4-WAY Cursor Control key to select a waypoint, route, track, group, or menu option. **To scroll through the list**, press the UP or DOWN Cursor keys. **To open a submenu**, press the RIGHT Cursor key. **To move to the higher level group**, or the higher level directory, press the LEFT Cursor key.



As you scroll through the Waypoint Management dialog box, **press the EXIT key to select the Options menu quickly**. Press the EXIT key twice to close the dialog box.

- A Sort By:** Select Sort By, and press the RIGHT Cursor key repeatedly to choose a sorting option for the waypoints, routes, tracks, and groups (A - Z, Z - A, Newest, Oldest, Distance, Icon). To start a more specific search, see *Options*.

- B Options:** Provides a submenu so that you can set the default group, create new navigation items (groups, waypoints, routes), and select and edit several items at once. Select Search By to search by Name, Distance, Date, Icon, or Icon Category. The Options menu will also change to show related menus such as Save or Paste.
- C Scroll and View:** Press the UP or DOWN Cursor keys to browse through the full list of saved waypoints, routes, tracks, and groups. The selected item is highlighted in white.
- D Submenu:** After an item is selected, press the RIGHT Cursor key to view the submenu.
- E Data Window:** As you scroll, the selected item's information is displayed at the bottom of the Waypoint Management dialog box.
- F Information:** Displays the default group where all new waypoints, routes, and tracks will be saved. In this illustration, Home is the default group. This field also changes to display instructions.
- G Directory:** Shows the directory structure and the currently selected group.
- H Arrows:** When arrows are displayed on a menu option, additional information or submenus are available. If the arrow points to the right, press the RIGHT Cursor key. If the arrow points to the left, press the LEFT Cursor key to move up to the higher level group directory.
- I Waypoint Icon:** The gray circle icon is the default waypoint icon. Waypoint names are alphanumeric and begin with WP. You can also change the icon, waypoint name, add it to a route, and more.
- J Track Icon:** Track names are saved with a date and time stamp, and certain track information can be edited (see *Edit your Waypoints, Routes, Tracks, and Groups*).
- K Route Icon:** Route names are alphanumeric and begin with R. To change the Route name and its waypoints, see *Edit your Waypoints, Routes, Tracks, and Groups*.

## Save, Create, or Delete a Waypoint

---

**Save your Current Position as a Waypoint:** On any view, press the MARK key to save the current position of the boat as a waypoint.

**Save the Cursor Position as a Waypoint:** On the **Chart** or **Combo View**, use the 4-WAY Cursor Control key to move the cursor to the position you want to save as a waypoint. Then press the MARK key to save the position as a waypoint.

**Save a Position from the Sonar History:** On any Sonar View or Down Imaging™ View, use the 4-WAY Cursor Control key to move the cursor to a feature in the sonar history. Press the MARK key to create a waypoint at the location where that sonar reading was taken. The new waypoint will also record the depth at that location.

***NOTE:** When you save a waypoint by any of these methods, a numerical waypoint name is automatically assigned. You can edit the waypoint information later to give it a different name and select an icon to represent it (see *Edit your Waypoints, Routes, Tracks, and Groups*).*

**Create a New Waypoint:** To create a waypoint that is NOT your current position, open the Waypoint Management dialog box. Select Options > New > New Waypoint. Use the 4-WAY Cursor Control key to set the available fields. See *Edit your Waypoints, Routes, Tracks, and Groups* for details.

**Delete a Waypoint:** Open the Waypoint Management dialog box. Select a Waypoint, and press the RIGHT Cursor key to open the Waypoint submenu. Select Delete, and press the RIGHT Cursor key. To remove the Waypoint from the group, choose **Selected**. To delete the waypoint from all groups, choose **All Instances**.

## Navigate to a Waypoint or Position

---

**Navigate to the Cursor Position:** From the Chart or Combo View, use the 4-WAY Cursor Control key to move the cursor to a position or waypoint on the display. Press the GOTO key.

**Navigate to a Selected Waypoint:** Press the GOTO key. Press the DOWN Cursor key to highlight a waypoint from the saved waypoints list, and press the RIGHT Cursor key to start navigation.

***NOTE:** By repeating the previous instructions, you can add more waypoints to create a longer multi-segment route.*

**Navigate to a Waypoint from the Waypoint Management Dialog Box:** Open the Waypoint Management dialog box. Select a Waypoint, and press the RIGHT Cursor key to open the Waypoint submenu. Select Go To, and press the RIGHT Cursor key.

**Skip a Waypoint:** From the Navigation X-Press™ Menu, select Skip Next Waypoint, and press the RIGHT Cursor key. If there is not another waypoint to skip to, navigation will be canceled.

**Cancel Navigation:** From the Navigation X-Press™ Menu, select Cancel Navigation, and press the RIGHT Cursor key. Canceling navigation removes the route and any waypoints created using the GOTO key, but it does not remove any saved routes from memory. You will be prompted to save the current route when you cancel navigation.

## Add a Waypoint Target or Trolling Grid

The **Waypoint Target** shows a target consisting of concentric circles in various distance ranges centered on the waypoint you choose. The **Trolling Grid** shows various distance ranges in grid format from the waypoint you choose. The trolling grid can be used as a guide when trolling around a waypoint.

Chart View with Target

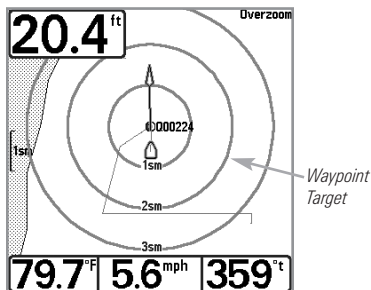

**Add a Waypoint Target:** Open the Waypoint Management dialog box and select a Waypoint. Press the RIGHT Cursor key, and select Target. Press the RIGHT Cursor key.

**Add a Trolling Grid:** Open the Waypoint Management dialog box and select a Waypoint. Press the RIGHT Cursor key, and select Grid. Press the RIGHT Cursor key. The grid can also be rotated to any heading by adjusting the Grid Rotation setting on the Navigation Main Menu.

Chart View with Grid

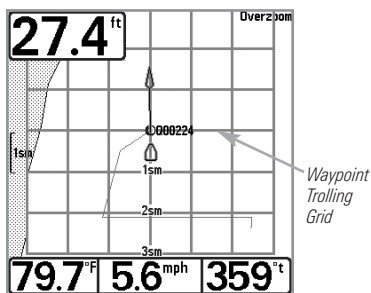

**Remove Target or Trolling Grid:** Press the MENU key once, and choose Remove Target or Remove Grid from the Navigation X-Press™ Menu, and press the RIGHT Cursor key.

**NOTE:** Only one waypoint can have either a target or a grid applied to it at one time. If you apply a target or a grid to a new waypoint, the original waypoint will lose its target or grid.

**NOTE:** The spacing of the rings on the waypoint target and the spacing of the grid lines on the trolling grid are the same as the length of the scale bar on the left edge of the display. Zooming in or out will decrease or increase the spacing, respectively.

## Routes

**Save the Current Route:** While you are navigating, the current route can be saved. From the Navigation X-Press™ Menu, select Save Current Route, and press the RIGHT Cursor key. Navigation will continue.

**Create a New Route:** Open the Waypoint Management dialog box. Select Options > New > New Route.

- **New Route Dialog Box:** Use the 4-WAY Cursor Control key to set the available fields (see *Edit your Waypoints, Routes, Tracks, and Groups* for details).
- **Plan Route:** Select Plan Route, and press the RIGHT Cursor key. The New Route dialog box closes so that you can select waypoints from the Waypoint Management dialog box. To add a selected waypoint to the route, press the RIGHT Cursor key. Repeat as needed. Select Save and press the RIGHT Cursor key.

Adding Waypoints to a Route

The screenshot shows a dialog box titled "Waypoints, Routes, Tracks". At the top, there is a "Sort By" dropdown menu set to "A to Z". Below this is a button labeled "Save RT001" with a circled 'A' next to it. The main area contains a list of waypoints: "WP014" (selected with a triangle icon and a circled 'B'), "WP015", and "Waypoint WP014 added to route RT001" (with a circled 'D'). Below the list is a "Home" button. At the bottom, there is a section for "New Route Information" with fields for "Name" (WP014), "Lat." (N 25°46.215'), "Long." (W 080°10.471'), and "Created" (2:43:54 PM 06/11/12). At the very bottom, there is a button labeled "Edit Route: RT001, then select Save" with a circled 'C' next to it.

**A Save:** Press the EXIT key to choose Save. Press the RIGHT Cursor key to confirm the save.

**B Selected Waypoint:** Press the RIGHT Cursor key to add it to the Route.

**C New Route Information:** Shows the Route's name and next steps.

**D confirmation** displays each time you add a waypoint to the Route.

**Travel a Saved Route:** Open the Waypoint Management dialog box. Select a saved route, and press the RIGHT Cursor key. Select Travel, and press the RIGHT Cursor key. Select Forward to travel the route in order. Select Reverse to travel the route in reverse order.

**Edit the Waypoint Order in a Route:** Open the Waypoint Management dialog box. Select a Route, and press the RIGHT Cursor key to open the Route submenu. Select Open, and then choose one of the following options:

- **Select Reverse**, and press the RIGHT Cursor key. This will quickly reverse the order of the route. Press the EXIT key to select Save. Press the RIGHT Cursor key to confirm your changes.

OR

- **Choose a Waypoint in a route**, and press the RIGHT Cursor key. Select Reorder, and press the RIGHT Cursor key. To move the waypoint up or down in the route order, press the UP or DOWN Cursor keys.

Press the EXIT key to select Save. Press the RIGHT Cursor key to confirm your changes.

Changing the Waypoint Order in a Route  
(two options)

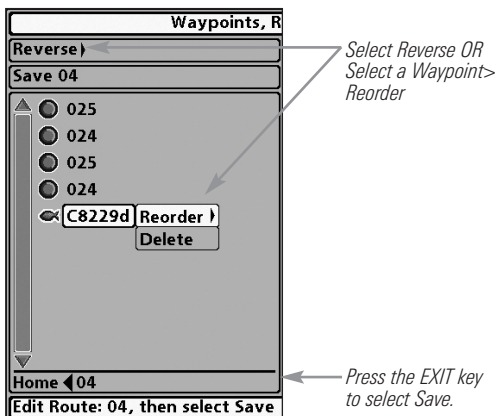

**Review Route Information:** Open the Waypoint Management dialog box. Select a saved route, and press the RIGHT Cursor key. Select Info, and press the RIGHT Cursor key. The Route Info dialog box displays the waypoints in the route. The distance and bearing from each waypoint to the next, as well as the distance and bearing from the current position to the first waypoint in the route will be displayed.

**Delete a Saved Route:** Open the Waypoint Management dialog box. Select a saved route, and press the RIGHT Cursor key. Select Delete from the submenu, and press the RIGHT Cursor key. To remove the route from the group, choose Selected. To delete the route from all groups, choose All Instances.

## Tracks

---

**Save the Current Track:** From the Navigation X-Press™ Menu, select Save Current Track, and press the RIGHT Cursor key. The track will remain on the display but will change from black to gray. To remove the track completely from the display, see *Hide or Display a Saved Track* and *Stop Tracking*.

*NOTE: When you save a track, a name is automatically assigned. The track name consists of a date/time stamp, but can be re-named later (see *Edit your Waypoints, Routes, Tracks, and Groups*).*

**Clear the Current Track:** From the Navigation X-Press™ Menu, select Clear Current Track, and press the RIGHT Cursor key. The track will be removed from the display and permanently deleted.

**Hide or Display a Saved Track:** Open the Waypoint Management dialog box. Select a saved track, and press the RIGHT Cursor key. Select Edit from the submenu. Use the 4-WAY Cursor Control key to set the track to visible or hidden (see *Edit your Waypoints, Routes, Tracks, and Groups* for details).

**Delete a Saved Track:** Open the Waypoint Management dialog box. Select a saved track, and press the RIGHT Cursor key. Select Delete from the submenu, and press the RIGHT Cursor key. To remove the track from the group, choose Selected. To delete the track from all groups, choose All Instances.



**Stop Tracking:** Press the MENU key twice to open the Main Menu. Select the Navigation Menu Tab > Current Track > Stop Tracking. **Stop Tracking** clears the current track, and the unit will not save trackpoints. See *Navigation Menu Tab: Current Track* for more information.



## Edit your Waypoints, Routes, Tracks, and Groups

Whether you are creating a new navigation item or editing it, you can use the same steps to customize a waypoint, route, track, or group. The available settings will depend on the type of item you are editing.

### Editing a Waypoint

Edit Waypoint	
Name	WP014
Icon Category	All
Icon	
Visible	
Latitude	N 25°46.215'
Longitude	W 080°10.471'
Save	
Created: 2:43:54 PM 06/11/12	



Visible on Chart View



Hidden on Chart View

**NOTE:** The Edit Waypoint dialog box is also available when you select a waypoint from the Navigation X-Press™ Menu.

**NOTE:** See your Humminbird® Waypoint Management Guide for more information about groups and the other great features of the Waypoint Management dialog box.

## Edit a Waypoint, Route, Track, or Group

1. Open the Waypoint Management dialog box.
2. **Open the Submenu:** Use the 4-WAY Cursor Control key to select a waypoint, route, track, or group. Press the RIGHT Cursor key to open the submenu.
3. Select Edit, and press the RIGHT Cursor key.
4. **Select a Field:** Use the 4-WAY Cursor Control key to move from field to field, and press the UP or DOWN Cursor keys to change the settings.

**Name:** Press the RIGHT or LEFT Cursor keys to move from space to space, and press the UP or DOWN Cursor keys to set the letter or number. All upper and lower case letters are available, as well as digits 0-9 and some punctuation symbols.

**Icon Category:** Press the UP or DOWN Cursor keys to scroll through the available categories. Select All to view all available icons. (All, Geometry, Alerts, Supplies, Navigation, Recreation, Fish, Environment)

**Icon:** Press the UP or DOWN Cursor keys to scroll through the available icons used to represent the waypoint in Chart View. The available icons are determined by the category selected in Icon Category.

**Visible:** Press the UP or DOWN Cursor keys to set the selected item to visible or hidden in the Chart View.

**Latitude/Longitude:** Press the RIGHT or LEFT Cursor keys to move from space to space, and press the UP or DOWN Cursor keys to set the letter or number.

***NOTE:** The available settings will depend on the type of item you are editing.*

## What's on the 500 Series™ Control Head

Your 500 Series™ Fishfinder interface is easy to use. A combination of keys and special features allows you to control what you see on the display. Refer to the following illustration, and see *Key Functions* for more information.

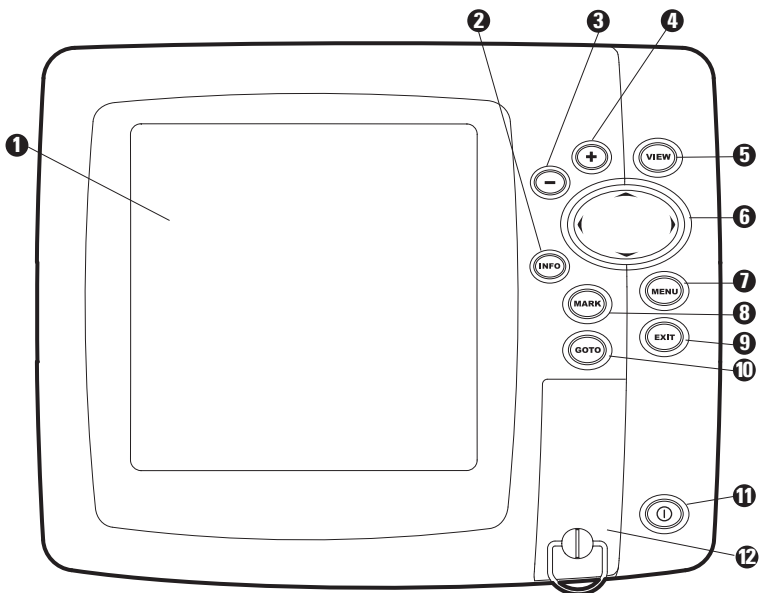

- 1 Screen
- 2 INFO key\*
- 3 ZOOM (-) key
- 4 ZOOM (+) key
- 5 VIEW key
- 6 4-WAY Cursor Control key  
(LEFT, RIGHT, UP, or DOWN Cursor keys)

- MENU key 7
- MARK key 8
- EXIT key 9
- GOTO key 10
- POWER/LIGHT key 11
- SD Card slot cover 12

\*Your control head will have one of the INFO keys shown here  . Both keys function in the same way.

## Key Functions

---

Your Fishfinder user interface consists of a set of easy-to-use keys that work with various on-screen views and menus to give you flexibility and control over your fishing experience.



### POWER/LIGHT Key

---

The POWER/LIGHT key is used to power the Fishfinder on and off. You can also use the POWER/LIGHT key to adjust the backlight and contrast of the display.

**Power On the control head:** Press the POWER/LIGHT key to power on the unit. When the Title screen is displayed, press the MENU key to access the Start-Up Options Menu.

**Power Off the control head:** Press and hold the POWER/LIGHT key for 3 seconds. A message will appear to indicate how many seconds there are until shutdown occurs. To ensure that shutdown occurs properly and any menu settings will be saved, your Fishfinder should always be turned off using the POWER/LIGHT key.

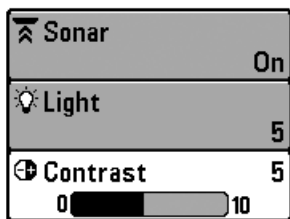

**Adjust the Backlight or the Display Contrast:** Press the POWER/LIGHT key to access the Light and Contrast submenu. Use the 4-WAY Cursor Control key to select Light or Contrast, and then use the LEFT or RIGHT Cursor key to change the settings. Press EXIT to exit the Light and Contrast submenu.

*NOTE: Your 500 Series™ Fishfinder will start up with the backlight on and will automatically turn it off to conserve power.*

**Turn Sonar On or Off:** From the Light and Contrast submenu, use the 4-WAY Cursor Control key to select Sonar. Use the LEFT or RIGHT Cursor key to change the setting. See *Setup Menu Tab: Sonar* for more information.



## VIEW Key

The VIEW key is used to cycle through all available views. Press the VIEW key to advance to the next view. Repeatedly pressing VIEW cycles through all views available. Views can be hidden to optimize the system to your fishing requirements (see *Views* or *Views Menu Tab*).

*NOTE: Press the EXIT key to cycle through the views in reverse order.*



## INFO Key

Press the INFO key while in Bird's Eye, Chart, or Combo View to display information about objects that are near an active cursor. If the cursor is not active, the Chart Info submenu will be displayed. See *Views: Viewing Cartography* for more information.

*NOTE: Your control head will have one of the keys shown here. Both keys function in the same way.*



## MENU Key

The MENU key is used to access the menu system. See *The Menu System* for more information.

- **Start-Up Options Menu:** Press the MENU key during the power up sequence to view the Start-Up Options menu.
- **X-Press™ Menu:** Press the MENU key once in any view to access the X-Press™ Menu, which provides frequently-used menu settings that correspond with the current view or navigation mode.
- **Main Menu:** Press the MENU key twice in any view to access the Main Menu, which is organized under tabbed headings to help you find a specific menu item quickly.

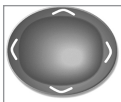

## 4-WAY Cursor Control Key

*(LEFT, RIGHT, UP, or DOWN Cursor keys)*

The 4-Way Cursor Control key has multiple functions, which depend on the view, menu, or situation.

- **Menu Selection:** Press the DOWN or UP Cursor keys to highlight a menu option, then press the RIGHT or LEFT Cursor keys to change a menu setting. The changes will be activated and saved immediately.
- **Freeze Frame:** In Sonar View and Down Imaging™ View, press any arrow on the 4-WAY Cursor Control key to freeze the display and move the active cursor to a location on the screen. A cursor dialog box will display to show the depth of the location you choose.
- **Active Cursor:** Press any arrow on the 4-WAY Cursor Control key, and the active cursor will appear on the screen.
- In any **Chart View**, the 4-WAY Cursor Control key also pans the charts and highlights decluttered waypoint icons.

*NOTE: In either Freeze Frame or Active Cursor mode, you can also make the cursor move diagonally by pressing in between two of the arrows on the 4-WAY Cursor Control key.*

- **Bird's Eye View:** The 4-WAY Cursor Control key controls the motion of the eye point.



## MARK Key

Press the MARK key while in any view to mark the position of a waypoint. The MARK key function works if you have the GPS receiver connected.

- **Active Cursor:** The waypoint will be marked at the cursor location.
- **Without Active Cursor:** The waypoint will be marked at the boat location.



## GOTO Key

---

The GOTO key has multiple functions, which depend on the situation.

- **Active Cursor:** Press the GOTO key while in any view to create a waypoint and start navigation towards that waypoint.
- **Without Active Cursor:** Press the GOTO key to display the saved waypoints list, and then highlight a waypoint. Press the RIGHT Cursor key to begin navigation.



## ZOOM (+/-) Key

---

In any of the **Navigation Views** or the **Sonar Zoom View**, press the +/-Zoom key to change the scale of the view to appear closer or farther away.



## EXIT Key

---

The EXIT key has multiple functions, which depend on the situation:

- **If an alarm is sounding**, press the EXIT key to cancel the alarm.
- **If a menu tab is selected**, press the EXIT key to exit the menu mode and return to the view.
- **If a menu is active**, press the EXIT key to return to the previous level in the menu system.
- **From any view**, press the EXIT key to cycle through the available views in reverse order.
- **If Freeze Frame is active**, press the EXIT key to return to a scrolling display.
- **If the Cursor is active**, press the EXIT key to remove the cursor from the display.

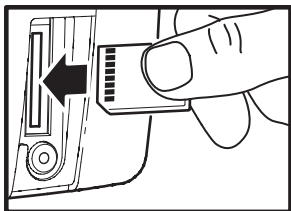

Inserting an SD Memory Card  
into the Card Slot

## SD Memory Card Slot

The SD memory card slot on your control head can be used with SD cards (optional-purchase required) to add detailed charts to your Fishfinder or export navigation data from your Fishfinder (see *Introduction to Navigation*).

**NOTE:** The SD Memory Cards require a separate purchase. For more information, visit our Web site at [humminbird.com](http://humminbird.com) or contact our Customer Resource Center at 1-800-633-1468.

### To insert an SD memory card:

1. Remove the SD memory card slot cover.
2. Position the SD memory card so that the label faces the right side of the unit, and insert the card into the slot. Press down on the card until it clicks into place.
3. Close the slot cover and turn the knob just 1/4 of a turn to close. Do NOT overtighten, as this will not improve water resistance and may damage the cover.
4. **To Remove:** Press the SD memory card into the slot and then release. The card will eject, and you can then pull the card from the slot.

**NOTE:** Do not leave the SD slot cover open. The slot cover should always be closed to prevent water damage to the unit.



## Add Maps to Your Fishfinder

---

Your Fishfinder includes a built-in UniMap™ with a more detailed map of North America (Domestic models) or a detailed map of Europe and Southeast Asia, including Australia and New Zealand (International models).

You can also purchase SD memory cards with additional chart information for a particular location.

***NOTE:** The SD Cards require a separate purchase. Your 500 Series™ Fishfinder supports Navionics® Gold, HotMaps® and HotMaps® Premium on SD card media. Your 500 Series™ Fishfinder does NOT support Navionics® Classic Charts or Platinum™ Cartography.*

- **Auto Select:** When you install the SD card in your control head, your Fishfinder will retrieve the chart and display it automatically.
- **Chart Select:** You can also choose which chart to display with the Chart Select menu option in the Navigation Menu Tab (see *Navigation Menu Tab: Chart Select*).
- **Chart Layers:** You can customize your Navigation Views by selecting which chart layers to display or hide (see *Navigation Menu Tab: Chart Detail Level*).
- **Map Borders:** Use the 4-WAY Cursor Control key to move the active cursor within a map border, and press the ZOOM + key to view the different map (see *Navigation Menu Tab: Map Borders*).
- **Menu Options:** The Navigation Menu Tab will change to display menu options that correspond with the active chart (see *Navigation Menu Tab*).

## Import Navigation Data

---

Review the following information before importing navigation data (waypoints, routes, tracks, or groups) into your Humminbird® unit.

- **Import Humminbird® Navigation Data:** Insert a loaded SD card into the control head card slot, and follow the on-screen prompts to import the waypoints, routes, tracks, and groups. In certain models, the data will import automatically.

**WARNING!** DO NOT import navigation data from unknown sources into your Humminbird® unit without first converting the data to the correct format using HumminbirdPC™. Importing corrupted data can cause the unit to malfunction, which can result in lost navigation data.

**NOTE:** For more information and instructions, see the FAQ (Frequently Asked Questions) section of our Web site at [humminbird.com](http://humminbird.com) or call our Customer Resource Center at 1-800-633-1468.

## Export Navigation Data

The Humminbird® Waypoint Management dialog box allows you to export all of your navigation items to an installed, unlocked SD Card. You can also export selected items.

For more information, see *Introduction to Navigation: What's on the Waypoint Management Dialog Box*. Also, see your Humminbird® Waypoint Management Guide for complete details.

It is important to back up your control head's data files (waypoints, routes, tracks, groups, recordings, etc.) periodically. You can also save, view, and organize your navigation data on your PC using HumminbirdPC™. See your Humminbird® online account for details at [humminbird.com](http://humminbird.com).

### To export all navigation data:

Use the following instructions to export all of the control head's waypoints, routes, tracks, and groups to an installed, unlocked SD card.

1. Insert an unlocked SD card into the SD card slot.
2. **Open the Waypoint Management Dialog Box:** Press the MENU key twice. Press the RIGHT Cursor key until the Navigation tab is selected. Select Waypoints, Routes, Tracks. Press the RIGHT Cursor key.
3. Select Options > Select All and... > Export.
4. Follow the on-screen instructions to confirm or cancel the export.

## To export selected navigation items:

Use the following instructions to select and export specific waypoints, routes, tracks, and groups to an installed, unlocked SD Card.

1. Insert an unlocked SD card into the SD card slot.
2. **Open the Waypoint Management Dialog Box:** Press the MENU key twice. Press the RIGHT Cursor key until the Navigation tab is selected. Select Waypoints, Routes, Tracks. Press the RIGHT Cursor key.
3. From a selected group directory in the Waypoint Management dialog box, select Options > Select Multiple and... > Export.
4. **Select Items:** Press the UP or DOWN Cursor keys to scroll through the waypoints, routes, tracks, and groups. Press the RIGHT Cursor key to select an item. Repeat as needed.
5. **Confirm Export:** When you are finished selecting items, press the EXIT key to select Export Selected. Press the RIGHT Cursor key and follow the on-screen instructions to confirm or cancel the export.

***NOTE:** If an SD memory card is not installed, an error message will be displayed. Insert the SD memory card and try again.*

***NOTE:** The SD memory cards and USB Memory Card Reader require separate purchases. The USB Memory Card Reader accessory can be used with your personal computer to view and organize your exported navigation data. To purchase this accessory, visit our Web site at [humminbird.com](http://humminbird.com) or contact our Customer Resource Center at 1-800-633-1468.*

# The Menu System

---

The Menu System is divided into easy-to-use menu modules as follows:

- **Start-Up Options Menu:** Press the MENU key during the power on sequence to view the Start-Up Options Menu. From the Start-Up Options Menu, you can choose the following Fishfinder Modes: Normal, Simulator, and System Status.
- **X-Press™ Menu:** The X-Press™ Menu provides a shortcut to the most frequently-used settings, and the options on the X-Press™ Menu correspond with the current view.
- **Main Menu:** The Main Menu is a standard set of menu settings which are organized under the following tabbed headings: Alarms, Sonar, Navigation, Setup, and Views.

***NOTE:** The X-Press™ Menu(s) and the Main Menu options can also be expanded or simplified by setting the User Mode to Advanced or Normal (see **Main Menu: User Mode**).*

## Start-Up Options Menu

---

Press the MENU key during the power on sequence to view the Start-Up Options Menu, and select one of the modes described on the following pages. Also, see *Power On* for additional information.

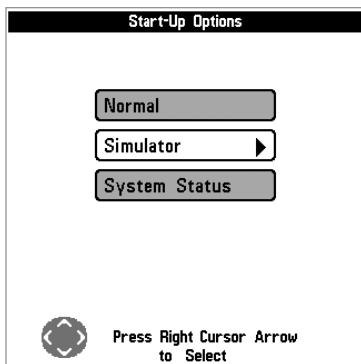

### Normal

---

Use **Normal** for on-the-water operation with a transducer connected. If a functioning transducer is connected, Normal operation will be selected automatically at power up, and your Fishfinder can be used on the water.

To exit Normal operation, power off your Fishfinder.

## Simulator

---

Use **Simulator** to learn how to use your Fishfinder before taking your boat on the water. The Simulator is a very powerful tool that provides a randomly-updated display which simulates on the water operation.

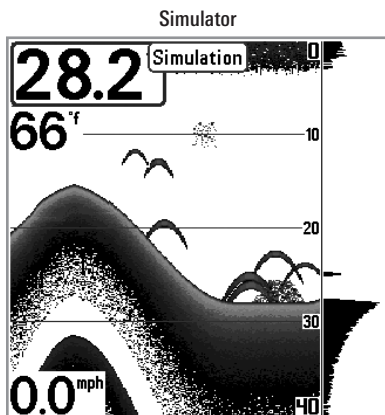

We recommend going through this manual while using the Simulator, since all of the menu function and affect the display in the same way as they would in Normal operation. Any menu changes you make will be saved for later use.

***NOTE:** It is important to select Simulator manually from the Start-Up Options Menu as opposed to letting the Fishfinder enter Simulator automatically (as it will if a transducer is not connected and you do nothing during power up).*

A message will appear often on the display to indicate Simulator mode.

To exit Simulator, power off your Fishfinder.

## System Status

---

Use **System Status** to view system connections and to conduct a unit self-test.

After you select System Status from the Start-Up Options Menu, press the VIEW key to display the following options:

- Self Test
- Accessory Test
- GPS Diagnostic View

To exit System Status, power off your Fishfinder.

**Self Test** displays results from the internal diagnostic self test, including unit serial number, Printed Circuit Board (PCB) serial number, software revision, total hours of operation, and the input voltage.

#### Self Test Screen

SYSTEM STATUS	
Self Test	
PASSED	
S/N	MODEL
-1-1-001	581
SOFTWARE VERSION	
4.141	
VOLTAGE	TOTAL TIME
14.1 <sup>V</sup>	74 <sup>hrs</sup>
PCB S/N	
-1-0001-001	
Press VIEW for Next Screen	

**Accessory Test** lists the accessories connected to the system.

#### Accessory Test Screen

SYSTEM STATUS	
ACCESSORY TEST	
Aux. Temperature	UNCONNECTED
GPS	CONNECTED
Speed	UNCONNECTED
Temperature	CONNECTED

**NOTE:** The speed accessory will be detected only if the paddlewheel has moved since your Fishfinder was powered up.

**GPS Diagnostic View** shows a sky chart and numerical data from the GPS receiver. The sky chart shows the location of each visible GPS satellite with its satellite number and a signal strength bar. A dark gray bar indicates that the satellite is being used to determine your current position. A light gray bar indicates that the satellite is being monitored, but is not yet being used.

This view also reports the current position, local time and date, and other numeric information. The current GPS Fix Type is reported as No Fix, 2D Fix, 3D Fix, or Enhanced. An Enhanced fix has been augmented using information from WAAS, EGNOS, or MSAS. A 3D or Enhanced Fix is required for navigation. HDOP (the Horizontal Dilution of Precision) is a GPS system parameter which depends on the current satellite configuration. HDOP is used to calculate the Estimated Position Error.

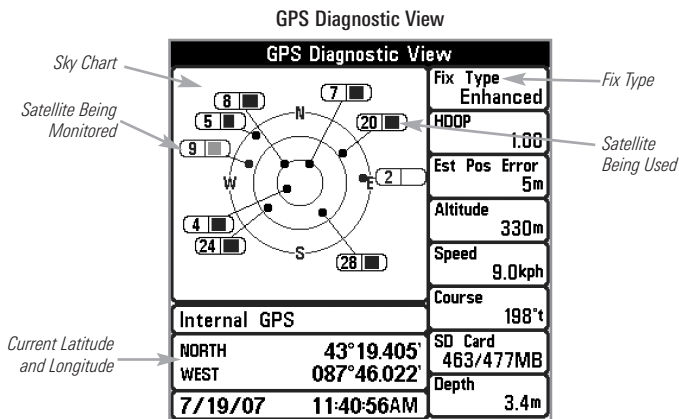



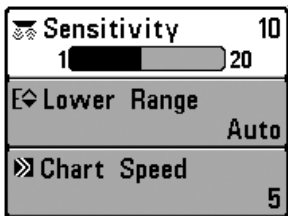

X-Press™ Menu

## X-Press™ Menu

The X-Press™ Menu provides a shortcut to your most frequently-used settings. The options provided on the X-Press™ Menu correspond with the current view. For example, if you are in a Sonar View and press the MENU key once, the Sonar X-Press™ Menu will display.

### To use an X-Press™ Menu:

1. In any view, press the MENU key once.
2. Press the UP or DOWN Cursor keys to highlight an X-Press™ Menu option, then use the RIGHT or LEFT Cursor keys to change the menu setting.

*NOTE: The X-Press™ Menu will collapse temporarily and the screen will update if it is affected by your menu setting change, which allows you to see the effects of your change immediately.*

3. Reactivate the X-Press™ Menu by pressing the UP or DOWN Cursor keys.

**Total Screen Update** - When you change any menu settings that affect the current view, the view will update immediately (i.e. you don't have to exit the menu to apply the change to the screen).

Menu options can be simplified or expanded by setting the User Mode to Normal or Advanced. See **Main Menu: User Mode** for details.

Alarms	
Depth Alarm	Off
Fish ID Alarm	○
Low Battery Alarm	Off
Temp. Alarm	Off
Off Course Alarm	300ft
Arrival Alarm	150ft
Drift Alarm	Off
Alarm Tone	Medium
Timer Setup	
Start Timer	

Main Menu (Normal User Mode)

## Main Menu

The Main Menu provides the standard set of menu options, including the settings that are changed less frequently. The Main Menu is organized under the following tabs to help you find a specific menu item quickly: Alarms, Sonar, Navigation, Setup, and Views.

*NOTE: Menu options can be expanded or simplified by setting the User Mode to Advanced or Normal. See **Main Menu: User Mode** for details.*

### To use the Main Menu:

1. In any view, press the MENU key twice.
2. Press the RIGHT or LEFT Cursor keys to highlight a menu tab.
3. Press the DOWN or UP Cursor keys to select a specific menu option under that tab.
4. Press the RIGHT or LEFT Cursor keys again to change a menu setting.
  - A down arrow at the bottom of a menu means that you can scroll to additional menu options using the DOWN Cursor key.
  - A right or left arrow on a menu option means that you can use the RIGHT or LEFT Cursor keys to make changes or to see more information.
  - Press the EXIT key to move quickly to the top of the tab.

**Total Screen Update** - When you change any menu settings that affect the current view, the view will update immediately (i.e. you don't have to exit the menu to apply the change to the screen).

## Quick Tips for the Main Menu

---

- **From any menu option on a menu tab**, press the EXIT key to jump directly to the top of the tab.
- **From the bottom of a menu tab**, press the DOWN Cursor key to jump directly to the top of the tab.
- **From the top of a menu tab**, press the LEFT or RIGHT Cursor keys to scroll to the next tab. You can also jump to the beginning or end of the tab rotation by repeatedly pressing the RIGHT or LEFT Cursor keys.
- **If there is a down arrow at the bottom of a menu tab**, press the DOWN Cursor key to scroll to additional menu options.
- **If there is a right or left arrow on a menu option**, press the RIGHT or LEFT Cursor keys to make setting changes or see more information.
- If you press MENU or EXIT to leave the Main Menu and then **return to the Main Menu at a later time**, the menu will open to the same tab as the last time the Main Menu was displayed.

## Note for all Menu Settings

---

The settings in all menus are adjusted in the same way. Simply use the 4-WAY Cursor Control key to highlight a menu option, and then change the settings or activate the option (see *Main Menu* or *X-Press™ Menu*).

Below is an example of how the menu options are described in this manual. Each description shows the menu option appearance, the available settings, and the specific control head settings required (i.e. advanced user mode, international only, view, navigation, or accessory).

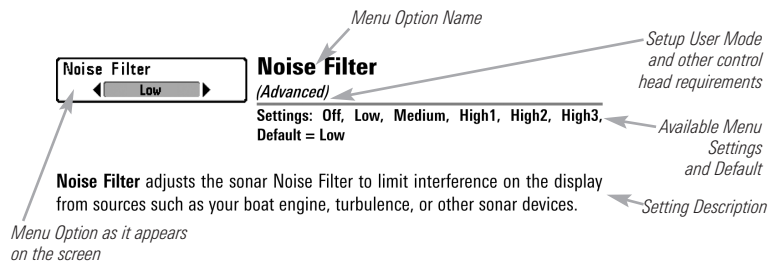

## User Mode (Normal or Advanced)

---

Menu options can be simplified or expanded by setting your Fishfinder User Mode to Normal or Advanced.

**Normal Mode** is the default setting when you first power on your 500 Series™ Fishfinder. Normal mode is provided for users who want greater simplicity and fewer menu choices.

**Advanced Mode** is provided for users who want the highest level of control over the Fishfinder. Several menu settings are added to the Main Menu when the User Mode is changed to Advanced.

### To change the User Mode setting:

1. Press the MENU key twice to access the Main Menu.
2. Press the RIGHT Cursor key until the Setup tab is selected.
3. Press the DOWN Cursor key to highlight User Mode on the Setup main menu.
4. Press the LEFT or RIGHT Cursor keys to change the User Mode setting. (Normal, Advanced, Default = Normal)

***NOTE:** Any changes made while in Advanced Mode will remain in effect after you switch back to Normal Mode.*







*For example, the Select Readouts menu option is available when the User Mode is set to Advanced. If you change the Select Readouts settings while operating in Advanced User mode, the Select Readouts you choose will continue to display on the screen even if you switch back to Normal User Mode.*

Sonar	
Beam Select	200kHz
Imaging Frequency	455kHz
Surface Clutter	5
SwitchFire	Clear Mode
Fish ID +	On
Fish ID Sensitivity	5
RTS Window	Narrow
Zoom Width	Narrow
Imaging Palette	Dark

Sonar Tab, Normal Mode

Sonar	
Beam Select	200kHz
Imaging Frequency	455kHz
Surface Clutter	5
SwitchFire	Clear Mode
Fish ID +	On
Fish ID Sensitivity	5
RTS Window	Narrow
Zoom Width	Narrow
455kHz Sensitivity	0
Depth Lines	On
Noise Filter	Low
Max Depth	Auto
Water Type	Fresh
Digital Depth Source	Auto
DI Pings	All Beams
Imaging Palette	Dark

Sonar Tab, Advanced Mode

 Cancel Navigation	
 Sensitivity	16
 Upper Range	0ft
 Lower Range	48ft
 Chart Speed	7
 Bottom View	Structure ID
 Bottom Lock	Off

Sonar X-Press™ Menu

## Sonar X-Press™ Menu

*(Sonar Views only)*

The **Sonar X-Press™ Menu** provides a shortcut to your most frequently-used settings. Press the MENU key once while in any of the Sonar Views to access the Sonar X-Press™ Menu.

*NOTE: Menu options can be expanded or simplified by setting the Fishfinder User Mode to Advanced or Normal. See **Main Menu: User Mode** for details.*

## Cancel Navigation

## Cancel Navigation

(only when Navigating)

Settings: Follow screen instructions to activate.

**Cancel Navigation** discards the current route and exits Navigation Mode. This menu option will only appear when you are currently navigating a route. This will not delete a previously-saved route.

## Sensitivity

## Sensitivity

Settings: Low = 1, High = 20; Default = 10

**Sensitivity** controls how much detail is shown on the display and will adjust the sensitivity of all sonar frequencies.

When operating in very clear water or greater depths, increase the sensitivity to see weaker returns that may be of interest. If the sensitivity is adjusted too high, the display may become too cluttered.

Decrease the sensitivity to eliminate the clutter from the display that is sometimes present in murky or muddy water. If Sensitivity is adjusted too low, the display may not show many sonar returns that could be fish.

*NOTE: The Sensitivity setting is a global setting and will adjust the sensitivity of all sonar frequencies.*

Sensitivity at Low

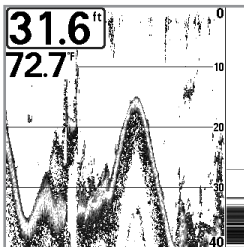

Sensitivity at Medium

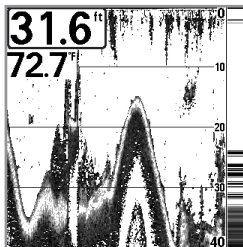

Sensitivity at High

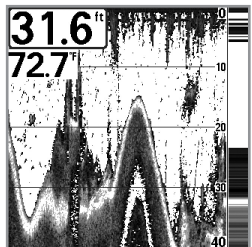

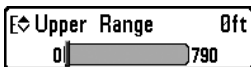

## Upper Range

*(Advanced: Sonar and Big Digits Views only)*

Settings: 0 to 790 feet or 0 to 257 meters [International Models only]; Default = 0 ft

**Upper Range** sets the shallowest depth range that will be displayed on the Sonar and Big Digits Views. Upper Range is often used with Lower Range.

For example, if you are only interested in the area between 20 and 50 feet deep, you should set the Upper Depth Range to 20 and the Lower Depth Range to 50. The Sonar View will then show the 30 foot area between 20 and 50 and will not show the surface or the bottom (assuming the bottom is deeper than 50 feet). Greater detail will be shown for the area between 20 and 50 feet.

*NOTE: A minimum distance of 10 feet will be maintained between the Upper and Lower Range regardless of the manual settings entered.*



## Lower Range

Settings: Auto to 800 feet, Auto to 260 meters [International Models only]; Default = Auto

**Lower Range** sets the deepest depth range that will be displayed by the unit.

**Auto:** The Lower Range will be adjusted by the unit to follow the bottom automatically. Auto is the default setting.

**Manual:** You can adjust the Lower Range to lock the unit on a particular depth. "M" will be displayed in the lower right corner of the screen to indicate the unit is in Manual mode. Adjust the Upper and Lower Range together to view a specific depth range, especially when looking for fish or bottom structure.

For example, if you are fishing in 60 feet of water but are only interested in the first 30 feet (surface to a depth of 30 feet), you should set the Lower Depth Range limit to 30. The display will show the 0 to 30 foot range, which allows you to see a more detailed view than you would see if the display went all the way to the bottom.

*NOTE: A minimum distance of 10 feet will be maintained between the Upper and Lower Range regardless of the manual settings entered.*



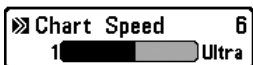

## Chart Speed

Settings: 1 - 9, Ultra, where 1 = Slow, 9 = Fast, Ultra = Fastest; Default = 5

**Chart Speed** determines the speed at which the sonar information moves across the display, and consequently the amount of detail shown.

A **faster speed** shows more information and is preferred by most anglers; however, the sonar information moves across the display quickly. A **slower speed** keeps the information on the display longer, but the bottom and fish details become compressed and may be difficult to interpret. Regardless of the Chart Speed setting, the RTS Window™ will update at the maximum rate possible for the depth conditions.

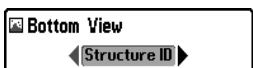

## Bottom View

Settings: Inverse, Structure ID®, WhiteLine™, Bottom Black; Default = Inverse

**Bottom View** selects the method used to represent bottom and structure on the display. See *What's on the Sonar Display: Sonar Returns and Bottom View* for more information.



## Bottom Lock

(Sonar Zoom View only)

Settings: Off, On; Default = Off

**Bottom Lock** changes the mode of the zoomed view in the Sonar Zoom View. Bottom Lock continuously graphs the bottom at a constant point on the display regardless of changes in depth. This “flattens” out the bottom contour, but is effective at showing fish on or near the bottom.



## Bottom Range

*(Sonar Zoom View only when Bottom Lock is On)*

Settings: 10 to 60 feet, 2 to 10 fathoms, or 3 to 20 meters  
(International Models only); Default = 15 ft

**Bottom Range** allows you to control how much of the water column, measured up from the bottom, is shown in the Sonar Zoom View. Choose a small value to see low-lying bottom structure or details of the bottom return. Choose a larger value to see large structure in deeper water.

***NOTE:** It is possible to set the Bottom Range to be greater than the depth. In this case, you may see surface clutter in a wavy band that mirrors changes in the depth.*

Cancel Navigation	
Imaging Sensitivity	10
Auto 	20
DI Enhance	
Upper Range	0ft
Lower Range	Auto
Chart Speed	10
Imaging Palette	Dark

Down Imaging™ X-Press™ Menu

## Down Imaging™ X-Press™ Menu

*(Down Imaging™ Views only)*

The **Down Imaging™ X-Press™ Menu** provides a shortcut to your most frequently-used settings. Press the MENU key once while in any of the Down Imaging™ Views to access the Down Imaging™ X-Press™ Menu.

***NOTE:** Menu options can be expanded or simplified by setting the User Mode to Advanced or Normal. See **Main Menu: User Mode** for details.*



## Cancel Navigation

*(only when Navigating)*

Settings: Follow screen instructions to activate.

**Cancel Navigation** discards the current route and exits Navigation Mode. This menu option will only appear when you are currently navigating a route. This will not delete a previously-saved route.



## Imaging Sensitivity

Settings: 1 to 20, where Low = 1, High = 20; Default = 10

**Imaging Sensitivity** (or **Down Sensitivity**) controls how the sonar returns are displayed on the Down Imaging™ Views.

**Increase the Imaging Sensitivity** to reveal weaker returns that may be of interest, especially in very clear water or greater depths. A high imaging sensitivity setting shows more sonar returns from small baitfish and suspended debris in the water; however if the sensitivity is adjusted too high, the display may become too cluttered.

**Decrease the Imaging Sensitivity** to eliminate the clutter from the display that is sometimes present in murky or muddy water. If the sensitivity is adjusted too low, the display may not show many sonar returns that could be fish.

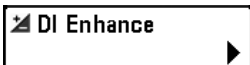

## DI Enhance

Settings: Press the RIGHT Cursor key.

**DI Enhance** allows you to adjust your Down Imaging™ View in the following categories: Sensitivity, Contrast, and Sharpness.

Whether you're searching the Down Imaging™ data for fish or certain bottom contour, the most effective settings will vary with the situation. The display will update as you adjust each category.



DI Enhance Submenu

- **Sensitivity:** Controls how much detail is shown on the display. When operating in very clear water or greater depths, increased sensitivity shows weaker returns that may be of interest. Decreasing the sensitivity eliminates the clutter from the display that is sometimes present in murky or muddy water. (1 to 20, where Low = 1, High = 20, Default = 10)

*NOTE: The Sensitivity can be adjusted from the DI Enhance dialog box or the Down Imaging™ X-Press™ Menu. The Sensitivity setting is provided here so that you can easily adjust the Down Imaging™ data with the other settings. See **Down Imaging™ X-Press™ Menu: Imaging Sensitivity** for more information.*

- **Contrast:** Accents the light and dark parts of the Down Imaging™ data to provide greater definition. (1 to 20, Default = 10)
- **Sharpness:** Filters the view and sharpens the edges of the Down Imaging™ data. (Low (L), Medium (M), High (H), Default = Off)

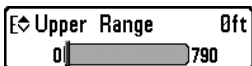

## Upper Range

*(Advanced)*

**Settings: 0 to 790 feet or 0 to 257 meters [International models only], Default = 0 ft**

**Upper Range** sets the shallowest depth range that will be displayed on the Down Imaging™ Views. Upper Range is often used with Lower Range.

For example, if you are only interested in the area between 20 and 50 feet deep, you should set the Upper Depth Range to 20 and the Lower Depth Range to 50. The Sonar View will then show the 30 foot area between 20 and 50 and will not show the surface or the bottom (assuming the bottom is deeper than 50 feet). Greater detail will be shown for the area between 20 and 50 feet.

*NOTE: A minimum distance of 10 feet will be maintained between the Upper and Lower Range regardless of the manual settings entered.*



## Lower Range

Settings: Auto to 800 feet, Auto to 260 meters [International Models only]; Default = Auto

**Lower Range** sets the deepest depth range that will be displayed by the unit.

**Auto:** The Lower Range will be adjusted by the unit to follow the bottom automatically. Auto is the default setting.

**Manual:** You can adjust the Lower Range to lock the unit on a particular depth. **M** will be displayed in the lower right corner of the screen to indicate the unit is in Manual mode. Adjust the Upper and Lower Range together to view a specific depth range, especially when looking for fish or bottom structure.

For example, if you are fishing in 60 feet of water but are only interested in the first 30 feet (surface to a depth of 30 feet) you should set the Lower Depth Range limit to 30. The display will show the 0 to 30 foot range, which allows you to see a more detailed view than you would see if the display went all the way to the bottom.

*NOTE: A minimum distance of 10 feet will be maintained between the Upper and Lower Range regardless of the settings entered manually.*

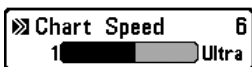

## Chart Speed

Settings: 1-9, Ultra, where 1 = Slow, 9 = Fast, Ultra = Fastest; Default = 5

**Chart Speed** determines the speed at which the sonar information moves across the display, and consequently, the amount of detail shown.













A **faster speed** shows more information and is preferred by most anglers; however, the sonar information moves across the display quickly. A **slower speed** keeps the information on the display longer, but the bottom and fish details become compressed and may be difficult to interpret.



## Imaging Palette

Settings: Dark, Light, Inverse; Default = Dark

**Imaging Palette** allows you to select which monochrome palette you would like to use for the Down Imaging™ display.

 Cancel Navigation
 Skip Next Waypoint
 Waypoint 001
 Cursor To Waypoint
 Chart Declutter
 Save Current Track
 Clear Current Track
 Save Current Route
 Sonar Window Medium
 Reset XTE
 Remove Target
 Remove Grid
 Waypoint 00153

Navigation X-Press™ Menu

## Navigation X-Press™ Menu

*(Navigation Views only)*

The **Navigation X-Press™ Menu** provides a shortcut to your most frequently-used settings. Press the MENU key once while in the Bird's Eye, Chart, or Combo View to access the Navigation X-Press™ Menu.

**NOTE:** Menu options will vary depending on system settings, such as whether you are currently navigating.

**NOTE:** Menu options can be expanded or simplified by setting the User Mode to Advanced or Normal. See *Main Menu: User Mode* for details.

See *Introduction to Navigation* and the Humminbird® Waypoint Management Guide for more information.



## Cancel Navigation

*(only when Navigating)*

---

Settings: Follow screen instructions to activate.

**Cancel Navigation** discards the current route and exits Navigation Mode. This menu option will only appear when you are currently navigating a route. This will not delete a previously-saved route.

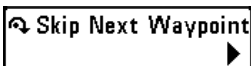

## Skip Next Waypoint

*(only when Navigating)*

---

Settings: Follow screen instructions to activate.

**Skip Next Waypoint** removes the next waypoint from the current route. This menu option will only appear when you are currently navigating a route.

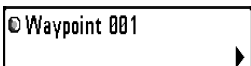

## Waypoint [Name]

*(Only with an active cursor on a waypoint)*

---

Settings: Edit, Delete, Target, Grid

**Waypoint [Name]** allows you to view the Waypoints submenu for the waypoint under your cursor. You can move the cursor onto an existing waypoint and press the MENU key once, or use **Cursor to Waypoint** to select a waypoint from the saved waypoints list.

*NOTE: See **Introduction to Navigation** and the Humminbird® Waypoint Management Guide for more information.*

### The Waypoint Submenu contains the following menu options:

**Edit** opens the Edit Waypoint dialog box so that you can edit the selected waypoint. See *Introduction to Navigation* and the Humminbird® Waypoint Management Guide for more information.

**Delete** allows you to delete the waypoint.

**Target** applies a target to the waypoint.

**Grid** applies a trolling grid to the waypoint.



**Cursor To Waypoint****Cursor to Waypoint***(Chart or Combo View only)***Settings:** Follow screen instructions to activate.

**Cursor to Waypoint** allows you to quickly move the cursor to any saved waypoint so that you can locate it or edit it. This X-Press™ Menu option only appears if you have saved waypoints.

**Chart Declutter****Chart Declutter****Settings:** Press the RIGHT Cursor key to activate.

**Chart Declutter** removes all chart layers except for land outlines, waypoints, routes, and tracks. The chart will stay decluttered for 10 seconds, and then it will refresh to its previous display settings. To refresh the view faster than 10 seconds, press the +/- Zoom keys.

*NOTE: See Navigation Menu Tab: Chart Detail Level for more information.*

**Save Current Track****Save Current Track****Settings:** Follow screen instructions to activate.

**Save Current Track** allows you to save the current track on the display. After the current track is saved, a new current track is started. Save Current Track appears on the Navigation X-Press™ Menu after navigation is stopped.

**Clear Current Track****Clear Current Track****Settings:** Follow screen instructions to activate.

**Clear Current Track** allows you to clear the current track on the display and start a new track at the present position.

**Save Current Route****Save Current Route***(only when Navigating)***Settings:** Follow screen instructions to activate.

**Save Current Route** allows you to save the current route being displayed. This menu option will only appear when you are currently navigating a route.



## Sonar Window

*(Combo View only)*

Settings: Wide, Medium, Narrow; Default = Medium

---

**Sonar Window** sets the size of the Sonar Window in the Combo View. Sonar Window can only be accessed from the Combo View.



## Reset XTE

*(only when Navigating)*

Settings: Press the RIGHT Cursor key to activate.

---

**Reset XTE** is available during navigation. When it is selected, the cross track error (XTE) will be recalculated from the boat's current position to the next waypoint in the route.

For example, when you've deviated from a route to navigate around an island, select Reset XTE to update the unit's course calculations from the current boat position instead of from the previous waypoint in the route.

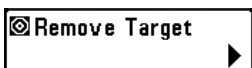

## Remove Target

*(only if a Target is Active)*

Settings: Press the RIGHT Cursor key to activate.

---

**Remove Target** removes the waypoint target from the display. This menu option will only appear when a target has already been applied to a waypoint.

*NOTE: See Introduction to Navigation: Add a Waypoint Target or Trolling Grid for more information.*

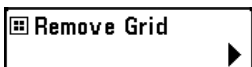

## Remove Grid

*(only if a Grid is Active)*

Settings: Press the RIGHT Cursor key to activate.

---

**Remove Grid** removes the waypoint grid from the display. This menu option will only appear when a grid has already been applied to a waypoint.

*NOTE: See Introduction to Navigation: Add a Waypoint Target or Trolling Grid for more information.*

**Waypoint [Name]** allows you to view the waypoints submenu for the most recently created waypoint. You must have pressed the MARK key at least once since you last powered up the Fishfinder for this menu option to appear.

*NOTE: See **Introduction to Navigation** and the Humminbird® **Waypoint Management Guide** for more information.*

**The Waypoint Submenu contains the following menu options:**

**Edit** opens the Edit Waypoint dialog box so that you can edit the selected waypoint. See ***Introduction to Navigation*** and the Humminbird® **Waypoint Management Guide** for more information.

**Delete** allows you to delete the waypoint.

**Go To** starts navigation to the waypoint.

**Target** applies a target to the waypoint.

**Grid** applies a trolling grid to the waypoint.

Alarms	
Depth Alarm	Off
Fish ID Alarm	<input type="radio"/>
Low Battery Alarm	Off
Temp. Alarm	Off
Off Course Alarm	300ft
Arrival Alarm	150ft
Drift Alarm	Off
Alarm Tone	Medium
Timer Setup	
Start Timer	

Alarms Menu Tab

## Alarms Menu Tab

From any view, press the MENU key twice to access the Main Menu. The Alarms tab will be the default selection.

*NOTE: When an alarm is triggered, you can silence it by pressing any key. The alarm will be silenced, and will not be triggered again until a new instance of the alarm condition is detected.*

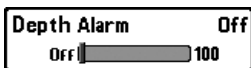

## Depth Alarm

Settings: Off, 1 to 100 feet, or 0.5 to 30 meters [International Models only]; Default = Off

**Depth Alarm** sounds when the depth becomes equal to or less than the menu setting.



## Fish ID Alarm

Settings: Off, All, Large/Medium, Large; Default = Off

**Fish ID Alarm** sounds when the Fishfinder detects fish that correspond to the alarm setting. Fish ID Alarm will only sound if Fish ID+™ is on. For example, if you've set the Fish ID Alarm to sound for Large fish only, the Fish ID alarm will sound when a large-sized fish is detected.

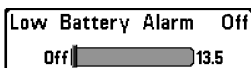
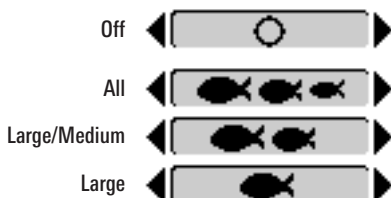

## Low Battery Alarm

Settings: Off, 8.5V - 13.5V; Default = Off

**Low Battery Alarm** sounds when the input battery voltage is equal to or less than the menu setting. The battery alarm will only sound for the battery that is connected to the Fishfinder. The Low Battery Alarm should be set to warn you when the battery voltage drops below the safety margin that you have determined.

For example, if you are running a trolling motor (battery operated), you would want to set the Low Battery Alarm to sound before the battery voltage drops too low for it to be used to start your main, gasoline-powered engine.

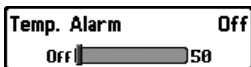

## Temp. Alarm

Settings: Off, 33-120 [Fahrenheit], 0-50 [Celsius];  
Default = Off

**Temp. Alarm** sounds when the water temperature detected by the Fishfinder reaches the Temp. Alarm setting, which is either set in degrees Fahrenheit or Celsius [International Models only].

For example, if the Temp. Alarm is set to 58 degrees Fahrenheit, and the water temperature falls from 60 degrees to 58 degrees, the Temp. Alarm will sound. Similarly, if the water temperature rises from 56 degrees to 58 degrees, the Temp. Alarm will also sound.



## Off Course Alarm

Settings: Off, 25 to 3000 feet, 10 to 1000 meters  
[International Models only]; Default = 300 ft, 100 m

**Off Course Alarm** allows you to set how far the boat is allowed to move off course before the Off Course Alarm will sound during navigation.

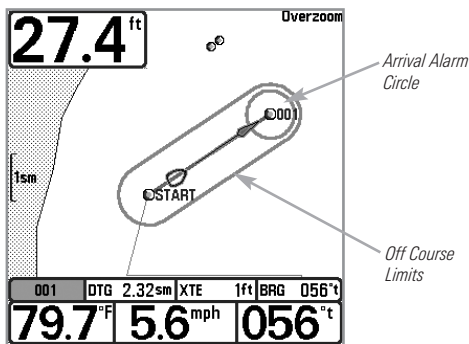

Arrival Alarm	150ft
Off	<input type="range" value="3000"/>

## Arrival Alarm

Settings: Off, 25 to 3000 feet, 10 to 1000 meters [International Models only]; Default = 150 ft, 50 m

**Arrival Alarm** sounds when the boat has either exceeded the distance to the destination waypoint, or has entered the Arrival Alarm Circle, based on the menu setting when navigating. Arrival Alarm allows you to set how close the boat must be to the destination waypoint before the Arrival Alarm will sound.

Drift Alarm	Off
Off	<input type="range" value="3000"/>

## Drift Alarm

Settings; Off, 25 to 3000 feet, 10 to 1000 meters [International Models only]; Default = Off

**Drift Alarm** allows you to set the size of a perimeter around the boat's anchored position. If the anchored boat drifts outside of that perimeter, the Drift Alarm will sound.

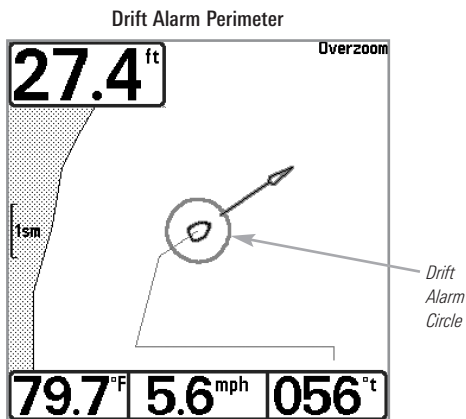

Alarm Tone
<input type="range" value="Medium"/>

## Alarm Tone

Settings: High, Medium, Low; Default = Medium

**Alarm Tone** selects the pitch of the alarm sound. A brief tone will be produced as you adjust the Alarm Tone so that you can select the tone that you can hear best.

## Timer Setup

## Timer Setup

Settings: Press the RIGHT Cursor key to open the dialog box.

**Timer Setup** allows you to open a dialog box to create settings for the Timer. You can also start the countdown from this dialog box. When the Timer is started, the clock counts down from the amount of time set in the dialog box.

Timer			
	Hours	Minutes	Seconds
Time ▶	02	: 15	: 23
Save and Start ▶			
Save and Close ▶			

- **Time:** Use the 4-WAY Cursor Control key to set the hours, minutes, and seconds.
- **Save and Start:** To start the Timer immediately, select Save and Start, and press the RIGHT Cursor key.
- **Save and Close:** To save your settings and start the Timer at a later time, select Save and Close, and press the RIGHT Cursor key. Also, see *Start Timer*.
- **Digital Readout:** To display the Timer on-screen as it counts down, see *Views: To Change the Digital Readouts*.

## Start Timer

## Start Timer

Settings: Press the RIGHT Cursor key to start the Timer.

**Start Timer** allows you to start the Timer using the saved countdown settings in the Timer Setup dialog box. To create the Timer settings, see *Timer Setup*.

## Stop Timer





## Stop Timer

(with the Timer running)

Settings: Press the RIGHT Cursor key to stop the Timer.

**Stop Timer** allows you to stop the Timer while it is counting down.



   	
Beam Select	200kHz
Imaging Frequency	455kHz
Surface Clutter	5
SwitchFire	Clear Mode
Fish ID +	On
Fish ID Sensitivity	5
RTS Window	Narrow
Zoom Width	Narrow
455kHz Sensitivity	0
Depth Lines	On
Noise Filter	Low
Max Depth	Auto
Water Type	Fresh
Digital Depth Source	Auto
DI Pings	All Beams
Imaging Palette	Dark

Sonar Menu Tab, Advanced Mode

## Sonar Menu Tab

Press the MENU key twice to access the Main Menu and then press the RIGHT Cursor key until the Sonar tab is selected.

*NOTE: Menu options can be expanded or simplified by setting the User Mode to Advanced or Normal. See Main Menu: User Mode for details.*

**Beam Select**

200kHz

**Beam Select**

Settings: 200 kHz, 455 kHz; Default = 200 kHz

**Beam Select** sets which sonar returns from the transducer will be displayed on the screen.

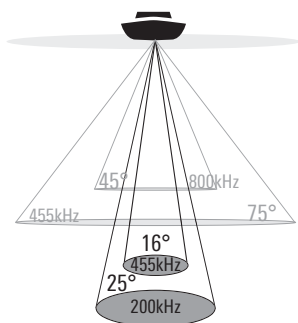

❖ 75 Degree Total Coverage

❖ Bottom Coverage = 1 x Depth

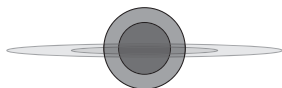

The **Down Imaging™** models allow you to choose 200 kHz or 455 kHz for conical sonar coverage in the traditional sonar views.

- When set to **200 kHz**, only the returns from the 200 kHz (25°) beam will be displayed.
- When set to **455 kHz**, only the returns from the 455 kHz (16°) narrow beam will be displayed.

## Imaging Frequency

◀ 455kHz ▶

# Imaging Frequency

*(Down Imaging™ Views only)*

Settings: 800 kHz or 455 kHz; Default = 455 kHz

**Imaging Frequency** allows you to select which frequency to apply to the Down Imaging™ beams (455 kHz or 800 kHz). For the best overall image quality and depth, select 455 kHz. For the sharpest image (but limited depth capability), select 800 kHz.

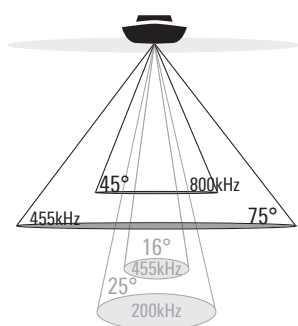

❖ 75 Degree Total Coverage

❖ Bottom Coverage = 1 x Depth

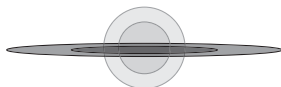

Surface Clutter

5

1

10

## Surface Clutter

Settings: Low = 1 to High = 10; Default = 5

**Surface Clutter** adjusts the filter that removes surface clutter noise caused by algae and aeration. The lower the setting, the less surface clutter will be displayed.

Surface Clutter

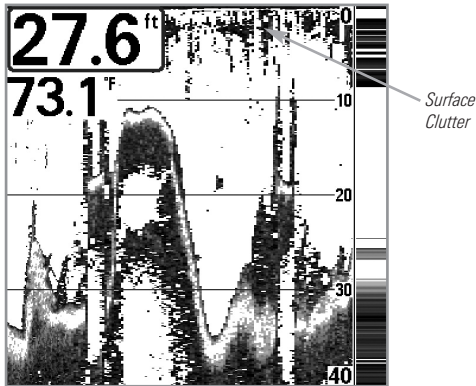

SwitchFire



Clear Mode



## SwitchFire™

Settings: Max Mode, Clear Mode; Default = Clear Mode

**SwitchFire™** controls how the sonar returns are displayed in the Sonar Views.

Choose **Max Mode** to see only raw sonar returns on the display. When Max Mode is selected, you will see the maximum sonar information available within the transducer beam, so more fish arches and better jig tracking are shown.

Choose **Clear Mode** to see less clutter and more fish size accuracy on the display. When Clear Mode is selected, the clutter is filtered, and sonar returns are interpreted to provide more details about the objects within the transducer beam, regardless of their location. In other words, a large arch on the display means a large fish has been detected.

Fish ID+™ uses advanced signal processing to interpret sonar returns and will display a Fish Symbol when very selective requirements are met. When a fish is detected, a fish icon and its depth are displayed above the return that has been classified as being a fish. Three different fish size icons represent the intensity of the sonar return and provide an indicator of relative fish size.

In **Down Imaging™ models**, targets detected in the 455 kHz conical beam are represented as hollow fish symbols, and targets detected in the 200 kHz conical beam are represented as shaded fish symbols.

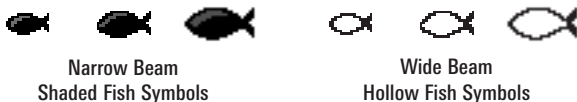

When Fish ID+™ is turned off, the Fishfinder shows only the raw sonar returns on the display. These returns will often result in “arches” forming on the display, indicating potential targets. Due to the transducer beam angle, the distance to a fish decreases as the fish moves into the beam, and then increases as it moves out again, creating a Fish Arch when this distance change is shown on the display. Boat speed, chart speed, and the position of the fish within the sonar beam greatly affect the shape of the arch.

Transducer Cone and Fish Arches

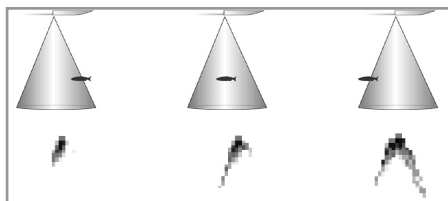

Fish ID Sensitivity 5  
1  10

## Fish ID Sensitivity

Settings: Low = 1, High = 10; Default = 5

**Fish ID Sensitivity** adjusts the threshold of the Fish ID+™ detection algorithms. Selecting a higher setting allows weaker returns to be displayed as fish. This is useful for identifying smaller fish species or baitfish. Selecting a lower setting displays fewer fish from weak sonar returns. This is helpful when seeking larger species of fish.

Fish ID Sensitivity is used in conjunction with Fish ID+™. Fish ID+™ must be On for Fish ID Sensitivity to affect the ability of the Fishfinder to identify sonar returns as fish.

RTS Window  
◀ Narrow ▶

## Real Time Sonar (RTS™) Window

Settings: Wide, Narrow, Off; Default = Narrow

**RTS Window™** sets the RTS Window™ to either Wide or Narrow, or turns it off in the Sonar View. The RTS Window™ always updates at the fastest rate possible and only displays returns that are within the transducer beam. See *What's on the Sonar Display* for more information.

*NOTE: The Wide RTS Window™ does not use grayscale.*

RTS Window™ (Wide)

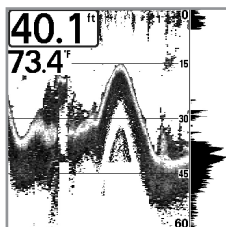

RTS Window™ (Narrow)

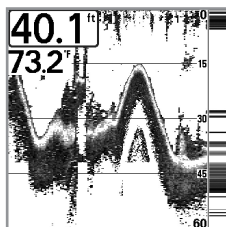

RTS Window™ (Off)

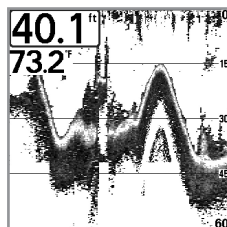

Zoom Width  
◀ Wide ▶

## Zoom Width

Settings: Narrow, Medium, Wide; Default = Wide

**Zoom Width** adjusts the width of the zoomed view on the Sonar Zoom View, which is on the left side of the display. See *Views: Sonar Zoom View* for more information.



## 455 kHz Sensitivity

*(Advanced, Down Imaging™ only)*

Settings: -10 to +10, Default = 0

**455 kHz Sensitivity** adjusts the sensitivity of the 455 kHz beam. Increase the sensitivity to display additional weak returns and decrease the sensitivity to display fewer weak returns.

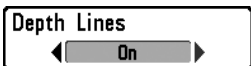

## Depth Lines

*(Advanced)*

Settings: Off, On; Default = On

**Depth Lines** divide the display into four equal sections which are separated by three horizontal depth lines. The depth of each line is displayed along the depth scale. You can turn Depth Lines On or Off.

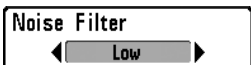
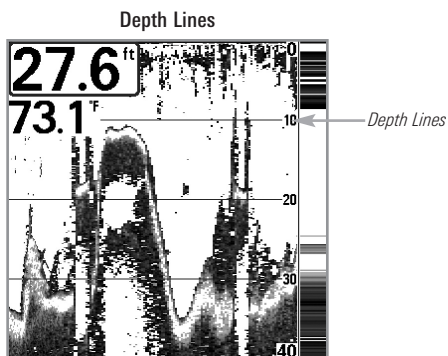

## Noise Filter

*(Advanced)*

Settings: Off, Low, Medium, High 1, High 2, High 3;  
Default = Low

**Noise Filter** adjusts the sonar Noise Filter to limit interference on the display from sources such as your boat engine, turbulence, or other sonar devices.

The Off setting removes all filtering. Low, Medium, and High1, High 2, High 3 settings add progressive filtering of the sonar returns. High 1, High 2, and High 3 are useful when there is excessive trolling motor noise, but in some deep water situations, the High settings may actually hinder your unit's ability to find the bottom.

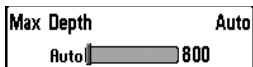

## Max Depth

(Advanced)

Settings: Auto, 10 to 800 feet, 3 to 260 meters  
[International Models only]; Default = Auto

**Max Depth** controls the maximum depth of operation. When Max Depth is set to Auto, the Fishfinder will acquire bottom readings as needed (within the capacity of the unit). When Max Depth is set to match your fishing maximum depth, your Fishfinder will not attempt to acquire sonar data below that depth, so more detail will be shown on the screen.

*NOTE: If the bottom is deeper than the Max Depth setting, the digital depth readout will flash, indicating that the Fishfinder cannot locate the bottom.*

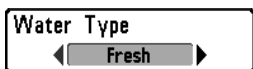

## Water Type

(Advanced)

Settings: Fresh, Salt (shallow), Salt (deep); Default = Fresh

**Water Type** configures your unit for operation in fresh or salt water. In salt water, you can also choose the shallow or deep setting.

Water Type affects the accuracy of deep water depth readings. In salt water, what would be considered a large fish might be 2 to 10 times bigger than a large fish in fresh water (depending on the type of fish you are seeking). The salt water setting allows for a greater range in fish size adjustment to account for this difference.





## Digital Depth Source

*(Advanced, optional-purchase transducers only)*

---

Settings: Auto, 2D Element; Default = Auto

**Digital Depth Source** specifies the beams that will be used to provide the depth for the digital depth readouts (see *Views* and *Setup Menu Tab: Select Readouts* for more information). It is important to set this menu option based on the transducer that is connected to the control head, as follows:

- If a **Down Imaging™ transducer** is connected to the control head, select Auto. Depending on the depth, Auto will automatically choose the 2D conical beams or the Down Imaging™ beams to display depth in the digital readout window. Auto is the default setting.
- If an **accessory transducer** is connected to the control head, select 2D Element. For example, if you connect an ice transducer to your Down Imaging™ unit, change the digital depth source to 2D Element in order to display depth in the digital readout window. The 2D Element setting should not be used with a Down Imaging™ transducer.

*NOTE: Visit our Web site at [humminbird.com](http://humminbird.com) to determine which accessory transducers are compatible with your Humminbird® Fishing System, or Contact our Customer Resource Center.*

*NOTE: When Digital Depth Source is set to 2D Element, the DI Only setting will be removed from the DI Pings menu. When DI Pings is set to DI Only, the 2D Element setting will be removed from the Digital Depth Source menu. See **DI Pings** for more information.*

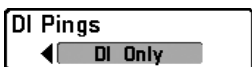

## DI Pings

*(Advanced, Down Imaging™ View and Chart/Down Combo View only)*

---

Settings: All Beams, DI Only; Default = All Beams

**DI Pings** allows you to select which beams will be used to display returns in the Down Imaging™ view.

Select **All Beams** to display returns from both the 2D sonar beams and the Down Imaging™ beams.

Select **DI Only** to display returns from the Down Imaging™ beams only. Selecting DI Only provides faster screen updates.

**NOTE:** When *DI Pings* is set to *DI Only*, the *2D Element* setting will be removed from the *Digital Depth Source* menu. When the *Digital Depth Source* is set to *2D Element*, the *DI Only* setting will be removed from the *DI Pings* menu. See **Digital Depth Source** for more information.

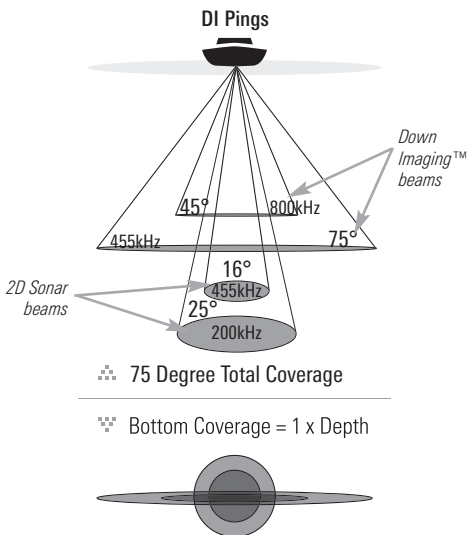

**NOTE:** See *How Sonar Works: Down Imaging™ Sonar* for more information.



## Imaging Palette

(Down Imaging™ Views only)

Settings: Dark, Light, Inverse; Default = Dark

**Imaging Palette** allows you to select which monochrome palette you would like to use for the Down Imaging™ display.

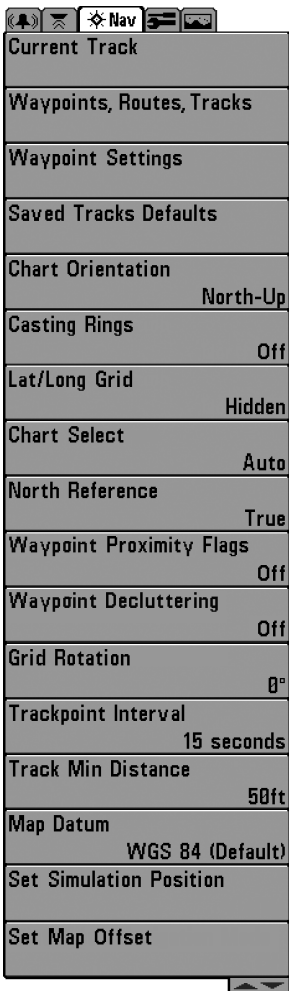

Navigation Menu Tab

## Navigation Menu Tab

Press the MENU key twice to access the Main Menu, then press the RIGHT Cursor key until the Navigation tab is selected.

*NOTE: Menu options will vary depending on system settings, such as whether you are currently navigating.*

*NOTE: Menu options can be expanded or simplified by setting the User Mode to Advanced or Normal. See **Main Menu: User Mode** for details.*

Current Track	Save	▶
	Clear	
	Appearance	
	Stop Tracking	

## Current Track

Settings: Save, Clear, Appearance, Stop Tracking

**Current Track** allows you to view the Current Track submenu. See *Introduction to Navigation: Tracks* for more information.

The Current Track Submenu contains the following menu options:

**Save** allows you to save the current track.

**Clear** allows you to delete the current track.

**Appearance** allows you to change the style and color of the current track (Breadcrumb Trail, Dashed Line, Solid Line or Wide Line, and if a line, the grayscale color of the line).

- If you choose **Hidden**, the unit continues to save trackpoints, but the track will not be displayed on the view.

**Stop Tracking** clears the current track and the unit will not save trackpoints. To resume saving the track, select Current Track > Start Tracking.

*NOTE: To save the depth information with the Current Track, it is important to save the track and also edit the name before powering off the control head.*

Waypoints, Routes, Tracks	▶
---------------------------	---

## Waypoints, Routes, Tracks

(Waypoint Management Dialog Box)

Settings: Press the RIGHT Cursor key to open the dialog box.

**Waypoints, Routes, Tracks** allows you to open the Waypoint Management dialog box. Use the Waypoint Management dialog box to create new waypoints and routes and organize your navigation data. You can also edit waypoint, route, and track information. Your navigation data can be saved into groups, sorted, copied, and exported to HumminbirdPC™.

See *Introduction to Navigation* and the Humminbird® Waypoint Management Guide for more information.

**Waypoint Settings** allows you to open the Waypoint Settings dialog box. Use the Waypoint Settings dialog box to set the waypoint icon category and the waypoint icon for all new waypoints. See *Introduction to Navigation: Edit your Waypoints, Routes, Tracks, and Groups* and the Humminbird® Waypoint Management Guide for details.

The Waypoint Settings dialog box includes the following options:

**Icon Category** allows you to select a waypoint icon category (All, Geometry, Alerts, Supplies, Navigation, Recreation, Fish, Environment). The Default Waypoint Icon also changes to match the selected category.

**Default Waypoint Icon** allows you select an icon for all new waypoints. To see the most icon choices, set the Icon Category to All.

**New Waypoint Icon:**

Select **Default**, and the system will automatically apply your settings to new waypoints.

If you choose **Select**, each time you mark a waypoint (by pressing the MARK key), you will be prompted to change the waypoint icon and category. To accept the current settings, press the MARK key again.

**Saved Tracks Defaults** allows you to open the Default Track dialog box. Use the dialog box to set the default track appearance for all newly-saved tracks.

The Saved Tracks dialog box includes the following options:

**Visibility** allows you to set new tracks to visible or hidden.

**Style** allows you to set the appearance and color of new tracks (Breadcrumb Trail, Dashed Line, Solid Line or Wide Line, and if a line, the grayscale color of the line).



## Chart Orientation

---

Settings: North-Up, Head Up, Course-Up; Default = North-Up

**Chart Orientation** allows you to select whether the Chart and Combo Views should be drawn North-Up, Head Up, or Course-Up. The Chart Orientation setting does not apply to the Bird's Eye View (see *Views: Chart View Orientation*).



## Casting Rings

---

(Advanced)

Settings: Off to 150 feet, 0 to 50 meters; Default = Off

**Casting Rings** allows you to display a circle around each waypoint on the Chart View. This menu option sets the distance that the Casting Ring will be displayed from the waypoint. Select Off to hide the Casting Rings.

*NOTE: Casting Rings are not applied to decluttered waypoints (see *Navigation Menu Tab: Waypoint Decluttering*).*

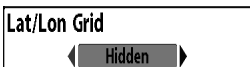

## Lat/Lon Grid

---

Settings: Hidden, Visible; Default = Hidden

**Lat/Lon Grid** allows you to display or hide a grid showing latitude and longitude lines.

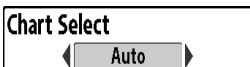

## Chart Select

---

(SD card in card slot)

Settings: Various, Default = Auto

**Chart Select** allows you to choose which chart to use if you have built-in charts or a map card. If you select Auto, you unit will select a chart automatically.



## North Reference

---

Settings: True, Magnetic; Default = True

**North Reference** allows you to have bearings displayed with one of two orientations: True North or Magnetic North.

**Waypoint Proximity Flags**
 Visible
**Waypoint Proximity Flags***(Advanced)*

Settings: Hidden, Visible; Default = Hidden

**Waypoint Proximity Flags** allows you to display or hide waypoint flags for the ten closest waypoints to the boat or active cursor. The flags show the distance from the boat (or active cursor) to each waypoint.

Waypoint Proximity Flags are also influenced by the zoom level and boat speed. The flags are only displayed if the chart range is less than .5 sm and the boat is traveling less than 15 mph.

Chart View with Waypoint Flags Turned On

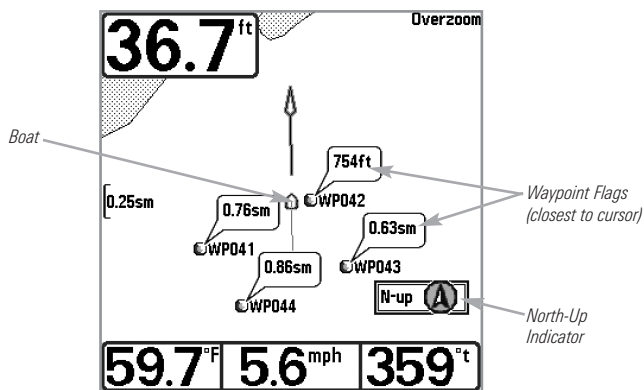
**Waypoint Decluttering**
 On
**Waypoint Decluttering***(Advanced)*

Settings: On, Off; Default = On

**Waypoint Decluttering** allows you to set the declutter feature On or Off. When two or more waypoints overlap, or are displayed close together on a chart view, the screen will automatically declutter—waypoint names will shorten and the waypoint icons will change into small gray icons. Select Off to display waypoints at regular size.

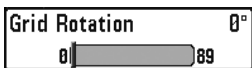

## Grid Rotation

Settings: 0° to 89°, Default = 0°

**Grid Rotation** allows you to set the orientation of the trolling grid in degrees, where a setting of 0° displays a standard North, South, East, West alignment. See *Introduction to Navigation: Add a Waypoint Target or Trolling Grid* for information.

*NOTE: This feature may appear as either Trolling Grid Rotation or Grid Rotation, depending on your model.*



## Trackpoint Interval

Settings: 1 second, 5 seconds, 10 seconds, 15 seconds, 30 seconds, or 60 seconds; Default = 1 second

**Trackpoint Interval** allows you to select the time period between trackpoints. The current track can only contain up to 20,000 trackpoints, so longer time periods cause the track to extend back further in time, but will be less detailed.

Trackpoint Interval works in conjunction with Track Min Distance. Both conditions must be met before a trackpoint is added to the current track. During slow travel or drift, setting both Trackpoint Interval and Track Min Distance to small values will allow you to increase the track resolution.



## Track Min Distance

(Advanced)

Settings: 1 to 300 feet, or 1 to 100 meters [International Units only]; Default = 16 ft, 5 m

**Track Min Distance** allows you to set a minimum distance of travel before a trackpoint is added to the track.

Track Min Distance works in conjunction with Trackpoint Interval. Both conditions must be met before a trackpoint is added to the current track. During slow travel or drift, setting both Trackpoint Interval and Track Min Distance to small values will allow you to increase the track resolution.



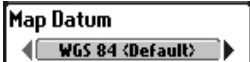

## Map Datum

(Advanced)

Settings: Various, Default = WGS 84

---

**Map Datum** allows you to change the map coordinate system used by the Fishfinder to match those of a paper map.

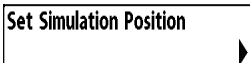

## Set Simulation Position

(Advanced)

Settings: Follow screen instructions to activate.

---

**Set Simulation Position** allows you to set the position of the boat used in the Simulator. Press any arrow on the 4-WAY Cursor Control key to activate the cursor and move it to the coordinates where you want start the simulation. Then confirm the position using the Set Simulation menu setting.

*NOTE: The cursor must be active in order for this procedure to work. If the cursor was not active before you began this procedure, an error message will appear. Exit the menu, set the cursor, then try again.*

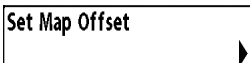

## Set Map Offset

(Advanced)

Settings: Follow screen instructions to activate.

---

**Set Map Offset** allows you to change the map offset used by your Fishfinder. Press the 4-WAY Cursor Control key to activate the cursor and move it to the location where the Map Offset will be applied. Then, confirm the map offset position using the Set Map Offset menu setting.

The Map Offset will be applied to all maps and not just the map that requires the correction. The Map Offset should be cleared if a different map is to be used.

*NOTE: The cursor must be active in order for this procedure to work. If the cursor was not active before you began this procedure, an error message will appear. Exit the menu, set the cursor, then try again.*

Clear Map Offset

## Clear Map Offset

(Advanced)

Settings: Follow screen instructions to activate.

**Clear Map Offset** allows you to clear the Map Offset. The Clear Map Offset menu option is available when Map Offset is active.

North Up Indicator



## North-Up Indicator

Settings: On, Off; Default = Off

**North-Up** allows you to display the North-Up icon on the screen to indicate the direction of True North. The icon also displays the Chart Orientation, and it will change as the orientation and the data source change. To set the Chart Orientation, see *Navigation Menu Tab*. Also, see *View Orientation*.

Course Projection Line



## Course Projection Line

Settings: Hidden, Standard, Single Vector, COG/SOG;  
Default = Standard

**Course Projection Line** displays an arrow or line, extending from the bow of the boat, that projects your current course and shows where the boat will go if you continue on your present course.

You can choose the style of the Course Projection Line as follows:

- **Standard** = arrow
- **Single Vector** = line
- **COG/SOG** = line with tick marks at set intervals from the boat. The tick marks are based on the speed calculation.

**Chart Detail Level** allows you to select how much chart detail you want displayed on the Navigation Views.

*NOTE: Some chart details are only available with optional-purchase SD cards.*

**Basic** shows land areas, ports, obstructions, and restricted areas.

**Navigation** shows nav aids, landmarks, ferryways, and navigation routes in addition to the Basic information.

**Underwater** shows depth contours, fishing areas, underwater wrecks, tides and currents in addition to the Basic and Navigation information.

**All** shows roads, buildings, railways, and other notations in addition to the Basic, Navigation, and Underwater information.

**Custom** (Advanced user mode) allows you to display or hide chart layers on the Navigation Views. The available chart layers include Navigable Canals, Boundaries, Restricted Areas, Coastline, Bridges, etc.

#### To customize the chart layers:

1. Select Chart Detail Level from the Navigation Menu Tab. Press the RIGHT Cursor key to select Custom. Selecting Custom adds the Custom Chart Layers menu to the Navigation menu.
2. Press the DOWN Cursor key to select Custom Chart Layers, and press the RIGHT Cursor key to access the submenu.
3. Use the 4-WAY Cursor key to select a layer and turn it on (visible) or off (hidden). All changes take place immediately.

Map Borders, shown with optional-purchase  
Navionics® Cartography with Custom Chart Layers



1 Anchorage Area

2 Drying Lines

3 Nav aids

4 Map Borders

5 Bridge (wavy lines)

Roads 6

Restricted Area 7

Other Points of Interest (POI) 8

Coastline 9

Map Borders

◀ MMC/SD Only ▶

Map Borders

Settings: Hidden, MMC/SD Only, All Visible;  
Default = MMC/SD Only

Map Borders allows you to display or hide map borders. The dotted lines of a Map Border indicate an area which contains a different map.

## Spot Soundings

◀ Hidden ▶

## Spot Soundings

Settings: Hidden, Visible; Default = Hidden

---

**Spot Soundings** allows you to display or hide spot soundings, which are depth measurements shown on the chart.

*NOTE: Spot Soundings are only available with optional-purchase SD cards.*

*NOTE: The cursor must be active in order for this procedure to work. If the cursor was not active before you began this procedure, an error message will appear. Exit the menu, set the cursor, then try again.*

## Auto Zoom

◀ On ▶

## Auto Zoom

(Advanced)

Settings: On, Off; Default = Off

---

**Auto Zoom** sets the Chart View to zoom automatically based on the speed of the boat. As the boat's speed increases, the chart range will increase. You can continue to use the +/- ZOOM keys to see more or less of the view, and Auto Zoom will resume after 20 seconds. To use only the +/- ZOOM keys to adjust the chart range, turn off Auto Zoom. See *Viewing Cartography* for more information.

*NOTE: The Auto Zoom setting does not apply to the Bird's Eye View.*

## Auto Range

◀ On ▶

## Auto Range

(Advanced)

Settings: On, Off; Default = Off

---

**Auto Range**, when turned on, sets the chart scale to the lowest range so that only the boat icon and the next waypoint in the route are displayed. See *Viewing Cartography* for more information.

**Zoom In/Out:** Press the +/- ZOOM keys. Using the +/- ZOOM keys will override Auto Range. To resume using Auto Range, press and hold the +/- ZOOM keys. See *Viewing Cartography* for more information.

*NOTE: The Auto Range setting does not apply to the Bird's Eye View.*

*NOTE: If Auto Range is turned on, it will override the Auto Zoom menu action.*



## Vessel Offset

Settings: On, Off; Default = Off

**Vessel Offset** allows you to display more of the Chart View based on the speed of the boat. Vessel Offset works with Offset Speed.

Turn on Vessel Offset, and set the speed threshold in Offset Speed. When the boat is moving below the Offset Speed setting, the boat icon will be displayed in the center of the Chart View. When the boat is moving at or above the Offset Speed setting, the boat icon will move to the edge of the view so that more of the Chart View is shown on-screen.

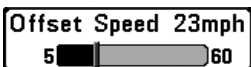

## Offset Speed

*(with Vessel Offset turned on)*

Settings: 5 to 60 mph, 5 to 50 kts, or 8 to 95 kph  
(International Models only); Default = 5 mph, 5 kts, 8 kph

**Offset Speed** allows you to see more of the Chart View when the boat is traveling at or above the Offset Speed setting. Vessel Offset must be turned on. See *Vessel Offset* for more information.

Setup	
Units - Depth	Feet
Units - Temp	°F
Units - Distance	Statute Miles
Units - Speed	mph
User Mode	Advanced
Language	English
Triplog Reset	
Restore Defaults	
Format Nav Directories	
Select Readouts	
Depth Offset	0.0ft
Temp. Offset	0.0°
Speed Calibration	0%
Local Time Zone	EST (UTC-5)
Daylight Saving Time	Off
Position Format	dd°mm.mmm'
Digits Format	Small tenths
Time Format	12-Hour
Date Format	mm/dd/yy
NMEA 0183 Output	Off
Sonar	On
Demonstration	Off

Setup Menu Tab

## Setup Menu Tab

From any view, press the MENU key twice to access the tabbed Main Menu, then press the RIGHT Cursor key until the Setup tab is selected.

*NOTE: Menu options will vary depending on which accessories are attached to the unit.*

*NOTE: Menu options can be expanded or simplified by setting the User Mode to Advanced or Normal. See **Main Menu: User Mode** for details.*

*The down arrow indicates more menu options. Press the DOWN Cursor key to scroll through the full menu list.*

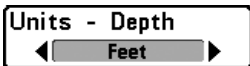

## Units - Depth

Settings: Domestic Models: Feet, Fathoms; International Models: Meters; Default = Feet/Meters

**Units - Depth** selects the units of measure for all depth-related readouts.

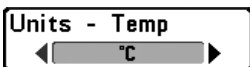

## Units - Temp

*(International only)*

Settings: Celsius, Fahrenheit; Default = Celsius

**Units - Temp** selects the units of measure for all temperature-related readouts. *International Models only.*



## Units - Distance

Settings: Domestic Models: Statute Miles, Nautical Miles, Default = Statute Miles; International Models: Meters/Kilometers, Meters/Nautical Miles, Feet/Statute Miles, Feet/Nautical Miles, Default = Meters/Kilometers

**Units - Distance** selects the units of measure for all distance-related readouts, and will appear in the menu if a Temp/Speed Accessory is connected and the paddlewheel has moved at least once, or if the GPS Receiver is connected.

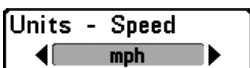

## Units - Speed

Settings: Domestic Models: mph, kts; International Models: kph; Default = mph/kph

**Units - Speed** selects the units of measure for speed-related readouts, and will appear in the menu if a Temp/Speed Accessory is connected and the paddlewheel has moved at least once, or if the GPS Receiver is connected.

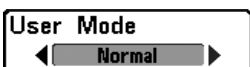

## User Mode

Settings: Normal, Advanced; Default = Normal

**User Mode** sets the menu system to Normal or Advanced. When set to Normal (default setting), the basic set of menu options are shown in the menu system. When set to Advanced, additional menu options are added to the menu system. See *Main Menu: User Mode* for details.



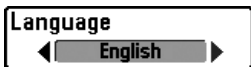

## Language

*(International only)*

Settings: Various, Default = English

---

**Language** selects the display language for menus. *International Models only.*

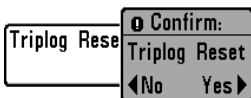

## Triplog Reset

Settings: Follow screen instructions to activate.

---

**Triplog Reset** resets the Triplog to zero, and will appear in the menu if a Temp/Speed Accessory is connected and the paddlewheel has moved at least once, or if the GPS Receiver is connected.

The Triplog provides the following information: timer for elapsed time, distance traveled since last reset, and average speed.

*NOTE: See Views to find out how to display Triplog information on the screen.*

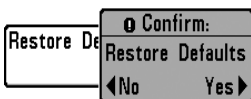

## Restore Defaults

Settings: Follow screen instructions to activate.

---

**Use this menu choice with caution!**

**Restore Defaults** resets ALL menu settings to their factory defaults.

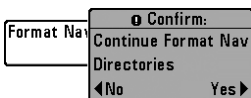

## Format Nav Directories

Settings: Press the RIGHT Cursor key and follow screen instructions.

---

**Use this menu choice with caution!**

**Restore Nav Directories** deletes ALL navigation data (waypoints, routes, tracks, and groups) and resets the navigation data directory in the Waypoint Management dialog box. You may need to reset the navigation directory if you've imported corrupted navigation data from an unknown source, which can cause the unit to malfunction (see *SD Memory Card Slot: Import Navigation Data*). Contact our Customer Resource Center before using this menu option.

*NOTE: It is important to back up your control head's data files periodically. Data files should also be saved to your PC before restoring the unit's defaults or updating the software. See your Humminbird® online account at [humminbird.com](http://humminbird.com) and the Waypoint Management guide.*

Select Readouts	
Readout 1	Temperature
Readout 2	Off
Readout 3	Off
Readout 4	Speed
Readout 5	Time+Date
Readout 6	Off

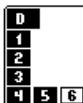

The readout position on the screen is shown in the Select Readouts Window.

Select Readouts

## Select Readouts

(Advanced, Sonar View and Down Imaging™ View only)

Settings: Various, Default = Off

**Select Readouts** sets the information to display in each of the 6 fixed-position data windows arranged around the left and bottom edges of the Sonar View screen. To leave the data window blank, select Off. See **Views** to change the Select Readouts.

Data windows can display readouts from supported accessories such as GPS Receiver or Temp/Speed. Each data window can be empty or contain one of the following information categories:

- Course
- Navigation
- Position
- Speed
- Temperature
- TTG (Time to Go to the next Waypoint)
- Time
- Time + Date
- Timer
- Triplog
- Voltage

**NOTE:** The availability of the digital readout information corresponds with the view selected, the accessory attached, and whether or not you are navigating.

Default Sonar View

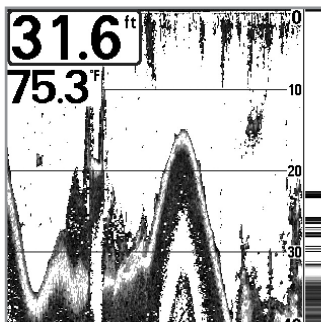

Sonar View with Select Readouts

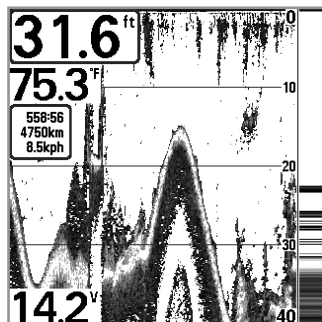



## Depth Offset

*(Advanced)*

Settings: -10.0 to 10.0 feet, or -3.0 to 3.0 meters [International Models only]; Default = 0 ft

**Depth Offset** will adjust the digital depth readout to indicate depth from the waterline or boat's keel. Enter a positive vertical measurement from the transducer to the waterline to read the depth from the waterline. Enter a negative vertical measurement from the transducer to keel to read the depth from the keel.



## Temp. Offset

*(Advanced, with Temp/Speed only)*

Settings: -10.0 to +10.0 degrees, Default = 0

**Temp. Offset** will adjust the temperature readout by the amount entered. This menu option is available if a Temp/Speed Accessory is connected and the paddlewheel has moved at least once.



## Speed Calibration

*(Advanced, with Temp/Speed only)*

Settings: -20% to +20%, Default = 0%

**Speed Calibration** will adjust the speed readout by the percentage entered, and will appear in the menu if a Temp/Speed Accessory is connected and the paddlewheel has moved at least once.



## Local Time Zone

*(Advanced)*

Settings: Various, Default = EST [UTC-5] - Eastern Standard Time

**Local Time Zone** selects your time zone in reference to the time reported by the GPS receiver when Time+Date is selected as a Digital Readout on the Sonar View (see *Setup Menu Tab: Select Readouts*).

**Daylight Saving Time**Off**Daylight Saving Time***(Advanced)*

Settings: Off, On; Default = Off

**Daylight Saving Time** adjusts the time display to account for local Daylight Saving Time when Time+Date is selected as a Digital Readout on the Sonar View (see *Setup Menu Tab: Select Readouts*).

Selecting On adds one hour to the time display adjusted for your local time zone. Selecting Off leaves the time display as adjusted for your local time zone.

**Position Format**dd°mm.mmm'**Position Format***(Advanced)*Settings: dd.ddddd°, dd°mm.mmm', or dd°mm'ss";  
Default = dd°mm.mmm'

**Position Format** selects the format of the latitude and longitude position display.

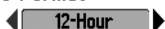
**Time Format**12-Hour**Time Format***(Advanced, International only)*

Settings: 12 hour, 24 hour; Default = 12 hour

**Time Format** changes the time format used by the unit. Time Format selects a 12 hour or 24 hour format for the time of day displayed when Time + Date is selected as a Digital Readout on the Sonar View (see *Setup Menu Tab: Select Readouts*).

**Date Format**mm/dd/yy**Date Format***(Advanced, International only)*Settings: mm/dd/yy, dd.mm.yy, yy.mm.dd; Default =  
mm/dd/yy

**Date Format** changes the date format used by the unit. Date Format selects the format for the date display when Time + Date is selected as a Digital Readout on the Sonar View (see *Setup Menu Tab: Select Readouts*).

**Digits Format**

◀ Small tenths ▶

**Digits Format***(Advanced)*

---

**Settings: Small tenths, Large tenths, No tenths;  
Default = Small tenths**

**Digits Format** adds a tenth decimal place to the readouts such as Temperature and Depth. Use the settings to change the display of the decimal place or remove it from the digital readouts. Examples of the different settings are displayed below. Also, see *Select Readouts* and *Views*.



Small tenths



Large tenths



No tenths

**NMEA Output**

◀ Off ▶

**NMEA 0183 Output***(Advanced)*

---

**Settings: Off, On; Default = Off**

**NMEA 0183 Output** turns the NMEA\* output on or off. NMEA Output should be turned On if you connect the NMEA Output wires of the GPS Receiver cable to another NMEA-compatible device, such as an autopilot.

*\*NMEA 0183 is a National Marine Electronics Association standard for data communication.*

***NOTE:** A separate purchase of accessory AS-HHGPS may be required for the NMEA output function.*

**The following NMEA sentences are output when NMEA Output is turned On:**

DPT - Depth

MTW - Water Temperature

GLL - Lat/Lon Position

GGA - GPS Fix Data

RMC - Recommended Minimum Specific GNSS Data

VTG - Course Over Ground and Ground Speed

ZDA - Time and Date

When navigating, the following NMEA sentences are also output when NMEA Output is turned On:

APB - Autopilot Sentence B

BWR - Bearing and Distance to Waypoint

RMB - Recommended Minimum Navigation Info

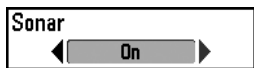

## Sonar

---

Settings: Off, On; Default = Off

**Sonar** sets whether the Sonar views are shown in the View rotation. Select Off to deactivate Sonar and remove the Sonar Views from the View rotation.

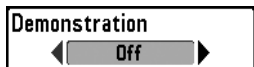

## Demonstration

---

Settings: Off, Visible; Default = Visible

**Demonstration** controls whether the Demonstration Mode is visible or off. The Demonstration Mode appears on the screen if you don't press any keys during the warning screen at power up. Menu settings cannot be saved in Demonstration (see *Power On* and *Start-Up Options Menu*).



## Sound Control

---

Settings: No Sounds, Alarms Only, All Sounds; Default = All Sounds

**Sound Control** allows you to set when the control head will beep or sound because of key presses and/or alarms.

Views	
Bird's Eye View	Visible
Chart View	Visible
Chart/Down Combo View	Visible
Combo View	Visible
Down Imaging View	Visible
Down/Sonar Combo View	Visible
Sonar View	Visible
Sonar Zoom View	Visible
Split Sonar View	Visible
Big Digits View	Visible
Self Test	Hidden
Accessory Test	Hidden
GPS Diagnostic View	Hidden

Views Menu Tab

## Views Menu Tab

From any view, press the MENU key twice to access the tabbed Main Menu, then press the RIGHT Cursor key until the Views tab is selected.

This menu tab allows you to set the available views to either hidden or visible in the view rotation. The view will be removed from the view rotation if it is set to Hidden and will be displayed in the view rotation if it is set to Visible.

*NOTE: See Views for more information.*

## Maintenance

---

Your Humminbird® fishfinder is designed to provide years of trouble free operation with very little maintenance. Use the following procedures to ensure your Humminbird® continues to deliver top performance.

### Control Head Maintenance

---

It is important to consider the following precautions when using your Humminbird® control head:

- Chemicals, such as those found in bug spray and sunscreen, may cause permanent damage to the control head screen. Such damage is not covered by the warranty.
- NEVER leave the control head in a closed car or trunk. The high temperatures generated in hot weather can damage the electronics.

Use the following information to keep the control head and screen clean.

- **Screen:** To clean the control head screen, use a mild soap (such as a non-abrasive liquid hand soap) and warm water. Wipe the screen dry with a soft cloth. Be careful to avoid scratching the screen. If water spots remain, use a solution of water and vinegar.

***WARNING!** Do not use a chemical glass cleaner on the screen. Chemicals in the solution may cause cracking in the lens of the unit.*

***NOTE:** Do not wipe the screen while dirt or grease is on the screen.*

- **Control Head:** If the control head comes into contact with salt spray, wipe the affected surfaces with a cloth dampened with fresh water.

### Transducer Maintenance

---

Use the following information to maintain the transducer operation.

- If your boat remains in the water for long periods of time, algae and other marine growth can reduce the effectiveness of the transducer. Periodically clean the face of the transducer with liquid detergent.

***NOTE:** To clean the transducer, you may need to pivot the transducer up in the bracket.*



- If your boat remains out of the water for a long period of time, it may take some time to wet the transducer when it is returned to the water. Small air bubbles can climb to the surface of the transducer and interfere with proper operation. These bubbles dissipate with time, or you can wipe the face of the transducer with your fingers after the transducer is in the water.

## **Troubleshooting**

---

Before contacting the Humminbird® Customer Resource Center, please read the following section. Taking the time to review these troubleshooting guidelines may allow you to solve a performance problem yourself, and therefore avoid sending your unit back for repair.

### **Fishfinder Doesn't Power Up**

---

If your Fishfinder doesn't power up, use the Installation Guide that also comes with it for specific confirmation details, making sure that:

- The power cable is properly connected to the Fishfinder control head.
- The power cable is wired correctly, with red to positive battery terminal and black to negative terminal or ground.
- The fuse is operational.
- The battery voltage of the power connector is at least 10 Volts.

Correct any known problems, including removing corrosion from the battery terminals or wiring, or actually replacing the battery if necessary.

### **Fishfinder Defaults to Simulator with a Transducer Attached**

---

A connected and functioning transducer will cause the newly-started Fishfinder to go into Normal operating mode automatically. If, when you power up the Fishfinder, it goes into Simulator mode automatically, even though a transducer is already connected, this means that the control head is not detecting the transducer. Perform the following troubleshooting tasks:

- Using the Installation Guide that also comes with your Fishfinder, check to make sure that the transducer cable is securely connected to the Fishfinder. Reconnect if necessary, and power up the Fishfinder again to see if this fixes the problem.
- Replace the non-functioning transducer with a known good transducer if available and power up the control head again.
- Check the transducer cable. Replace the transducer if the cable is damaged or corroded.

## Display Problems

---

There are several main conditions or sources of possible interference that may cause problems with the quality of the information displayed on the control head. Look in the following table for some symptoms of display problems and possible solutions:

Problem	Possible Cause
<b>The control head loses power at high speeds.</b>	If the power output of your boat's engine is unregulated, the control head may be protecting itself using its over-voltage protection feature. Make sure the input voltage does not exceed 20 Volts.
<b>When the boat moves at higher speeds, the bottom disappears or suddenly weakens, or the display contains gaps.</b>	<p>The transducer position may need to be adjusted. A mix of air and water flowing around the transducer (cavitation) may be interfering with the interpretation of sonar data. See your Installation Guide for suggestions on adjusting the transducer position.</p> <p>Electrical noise from the boat's engine may be interfering with sonar reception. See <i>Finding the Cause of Noise</i> for more information.</p>
<b>There are no fish detected, even when you know they are in the water under the boat, or sonar readings seem weak or faulty.</b>	<p>Sonar readings may be affected if the transducer is not positioned correctly (i.e. mounted at an angle, not straight down), or there is some kind of mechanical interference, either because it is mounted inside a hull that is too thick for proper sonar transmission, the bond between the transducer and the hull is not airtight, or because the transducer is dirty. Check with your Installation Guide for guidance on re-positioning the transducer, and make sure the transducer is clean.</p> <p>Low battery voltage may be affecting the power of signal transmission.</p> <p>Electrical noise from the boat's engine may be interfering with sonar reception. See <i>Finding the Cause of Noise</i> for more information.</p>

## Finding the Cause of Noise

---

Electrical noise usually affects the display with many black dots at high speeds, and high sensitivity readings. One or more of the following sources can cause noise or interference:

Possible Source of Noise	Isolation
<b>Other electronic devices</b>	Turn off any nearby electronic devices to see if the problem goes away, then turn them on one at a time to see if the noise re-appears.
<b>The boat's engine</b>	To determine whether the boat's engine is the source of the noise, increase the RPMs while the boat is in neutral and stationary to see if the noise increases proportionately; if noise appears when you rev the engine, the problem could be the spark plugs, alternator, or tachometer wiring. Replace the spark plugs with resistor plugs, install an alternator filter, or route the control head power and transducer cables away from the engine wiring.
<b>Cavitation from the boat's propeller</b>	Turbulence created by the propeller can cause noise; make sure the transducer is mounted at least 15" (38 cm) from the propeller, and that the water flows smoothly over the face of the transducer at all times.

## 581i DI Specifications

---

Depth Capability	250 ft (76 m) Down Imaging™ 600 ft (183 m) traditional sonar
Power Output	500 Watts (RMS), 4000 Watts (Peak to Peak)
Operating Frequency	455 kHz and 800 kHz (Down Imaging™) 200 kHz and 455 kHz (traditional sonar)
Area of Coverage	Down Imaging™: 75° @ -10 dB in 455 kHz 45° @ -10 dB in 800 kHz Traditional sonar: 25° @ -10 dB in 200 kHz 16° @ -10 dB in 455 kHz
Target Separation	2 1/2 Inches (63.5 mm)
Power Requirement	10-20 VDC
LCD Matrix	640 V x 320 H
Transducer	XNT 9 DI T (includes built-in temperature probe)
Transducer Cable Length	20 ft (6 m)
Current Draw	400 mA
IPX Rating	IP67 Waterproof/Submersible @ 1 m for 30 minutes and dust tight

*NOTE: Humminbird® verifies maximum stated depth in saltwater conditions, but actual depth performance may vary due to transducer installation, water type, thermal layers, bottom composition and slope.*

*NOTE: Product specifications and features are subject to change without notice.*

## 581i HD DI Specifications

---

Depth Capability	250 ft (76 m) Down Imaging™ 600 ft (183 m) traditional sonar
Power Output	500 Watts (RMS), 4000 Watts (Peak to Peak)
Operating Frequency	455 kHz and 800 kHz (Down Imaging™) 200 kHz and 455 kHz (traditional sonar)
Area of Coverage	Down Imaging™: 75° @ -10 dB in 455 kHz 45° @ -10 dB in 800 kHz Traditional sonar: 25° @ -10 dB in 200 kHz 16° @ -10 dB in 455 kHz
Target Separation	2 1/2 Inches (63.5 mm)
Power Requirement	10-20 VDC
LCD Matrix	640 V x 320 H
Transducer	XNT 9 DI T (includes built-in temperature probe)
Transducer Cable Length	20 ft (6 m)
Current Draw	400 mA
IPX Rating	IP67 Waterproof/Submersible @ 1 m for 30 minutes and dust tight

*NOTE: Humminbird® verifies maximum stated depth in saltwater conditions, but actual depth performance may vary due to transducer installation, water type, thermal layers, bottom composition and slope.*

*NOTE: Product specifications and features are subject to change without notice.*

**ENVIRONMENTAL COMPLIANCE STATEMENT:** *It is the intention of Johnson Outdoors Marine Electronics, Inc. to be a responsible corporate citizen, operating in compliance with known and applicable environmental regulations, and a good neighbor in the communities where we make or sell our products.*

**WEEE DIRECTIVE:** *EU Directive 2002/96/EC "Waste of Electrical and Electronic Equipment Directive (WEEE)" impacts most distributors, sellers, and manufacturers of consumer electronics in the European Union. The WEEE Directive requires the producer of consumer electronics to take responsibility for the management of waste from their products to achieve environmentally responsible disposal during the product life cycle.*

*WEEE compliance may not be required in your location for electrical & electronic equipment (EEE), nor may it be required for EEE designed and intended as fixed or temporary installation in transportation vehicles such as automobiles, aircraft, and boats. In some European Union member states, these vehicles are considered outside of the scope of the Directive, and EEE for those applications can be considered excluded from the WEEE Directive requirement.*



*This symbol (WEEE wheelie bin) on product indicates the product must not be disposed of with other household refuse. It must be disposed of and collected for recycling and recovery of waste EEE. Johnson Outdoors Marine Electronics, Inc. will  mark all EEE products in accordance with the WEEE Directive. It is our goal to comply in the collection, treatment, recovery, and environmentally sound disposal of those products; however, these requirements do vary within European Union member states. For more information about where you should dispose of your waste equipment for recycling and recovery and/or your European Union member state requirements, please contact your dealer or distributor from which your product was purchased.*

# Glossary

---

## Sonar Terms:

**Beam (Sonar Beam)** The wide, cone-shaped projection of sound waves formed as sound travels underwater. See *Cone Angle*.

**Bottom Contour** The profile of the bottom graphed to the display as the depth changes.

**Bottom Hardness** The density (or composition) of the bottom. Varying levels of hardness can be determined by interpreting the “thickness” of the main sonar return. Hard returns appear thin and black, softer returns appear thicker and less black. It is important to note that a sonar return from a sloping bottom can have the appearance of a softer bottom.

**Cavitation** The effect of air bubbles created as the propeller rotates and the boat moves through the water.

**Cone Angle** The angular measurement of the sonar beam at a specific dB down point (i.e. -10 dB). See *dB Down Point*.

**Dead Zone** The area of the sonar beam that receives the sonar signal after the main bottom return. Fish and other objects close to the bottom that fall within the dead zone will probably not be visible in the sonar beam. Precision sonar beams, such as the Humminbird® 20° beam, have a smaller dead zone than wider sonar beams.

**Decibel** The measurement for sound pressure level, or “intensity” of the sonar return. See *dB Down Point*.

**dB Down Point** The standard decibel level at which the sonar cone angle is measured, and is written as “@ -10 dB” or “@ -3 dB”. Measurements at smaller down points (bigger negative numbers) indicate that the less intensive sonar signals are being used for the measurement.

**Display, FSTN (Film Super-Twist Nematic)** FSTN is a monochrome display technology characterized by black, high-contrast pixels. All monochrome fixed mount Humminbird® products use FSTN technology.

**Frequency** A measure of the number of sound wave cycles per second of a sound impulse transmitted underwater. A typical frequency for fishfinders is 200 kHz, which offers a good balance of performance under many conditions. Lower frequencies, such as 50 kHz, are capable of penetrating to greater depths, but with less resolution. Higher frequencies, such as 455 kHz, offer greater resolution, but are limited in depth performance. Humminbird® uses a variety of frequencies that are optimized for specific applications.



**Grayscale** The use of varying shades of gray to represent the strength of the sonar signal on the display. Traditionally, the strongest sonar signals are represented in black, and progressively weaker signals are represented in progressively lighter shades of gray.

**Noise** The unintentional, external sound waves that interfere with the optimal operation of sonar. Noise appears as random “dots” on the display and is caused by a variety of sources. Many Humminbird® products have a Noise Filter menu setting that allows the user to clear the screen of noise that is difficult to eliminate (also, see *Troubleshooting*).

**Pixels** The “picture elements”, or small square blocks, that make up the image on the LCD. Measured as a vertical by horizontal number (i.e. 640V x 320H), this key specification typically indicates the quality of resolution. In fishfinders, the total resolution (vertical multiplied by horizontal) is often less important than the “Vertical Pixel” resolution because a greater number of vertical pixels provide finer resolution of targets detected by sonar. Sonar information on the horizontal axis can vary greatly, depending on boat speed and the Chart Speed setting.

**Power Output** The amount of sound energy emitted into the water by the transducer’s transmitter. Power output is measured using either RMS (Root Mean Square) or P-T-P (Peak-to-Peak) measurement systems. Either method is acceptable, but it is important when comparing power outputs, to make sure that the same measurement system is being used for both outputs, because P-T-P numbers are 8 times higher than RMS numbers. Greater power output allows the sonar signal to penetrate through weeds and thermoclines, reach deeper depths and operate more effectively in noisy environments, such as when the boat is running at high speed.

**Pulse Width (Pulse Length)** The length of time that a sonar sound burst is transmitted into the water. Shorter pulse widths provide better target separation, but cannot travel to great depths. Longer pulse widths provide better depth penetration, but result in poorer target separation. Humminbird® varies pulse width based on depth to optimize both target separation and depth performance. See *Target Separation*.

**Second Return** Describes the appearance of a second sonar return below the primary sonar return (bottom contour) at exactly twice the true depth. The second return is caused by the same sonar energy bouncing off the bottom once, rebounding to the water surface and then traveling back down to the bottom to be reflected again. Second returns are more common in shallow water and over hard bottoms; it is possible to see a third sonar return under some circumstances. The second return provides useful information to help determine bottom hardness, as areas with harder bottoms will generally create a second return. The second return can be used as a guide to set Sensitivity when in shallower water.

**SONAR (SOund and NAVigation Ranging)** Sonar technology uses precision sound bursts transmitted underwater to determine the distance and other attributes of objects in the water. Distance can be determined because the speed of sound in water is constant, and the time for the signal to return is measured. Sound also travels very quickly underwater, making sonar a responsive, cost-effective tool. Sonar is the basic technology behind all recreational and commercial fishfinding and depthfinding devices.

**Sonar Update Rate** The number of times per second that the transducer's transmitter/receiver sends and receives sonar signals. A very fast sonar update rate collects more information and provides a more detailed image of the bottom, fish, and structure. Many Humminbird® units operate at up to 40 times per second when in single frequency operation. Due to the limitation of the speed of sound in water, the update rate begins to slow as depth increases to deeper than 50 feet. In very shallow water (less than 10 feet), however, update rates as much as 60 times per second can be achieved.

**Speed** The rate at which the boat moves through the water. Boat speed can be measured as Speed Over Ground or Speed Through Water. Speed Over Ground is provided by GPS, and is the measurement of the boats progress across a given distance. Speed Through Water is provided by a speed paddlewheel, and is the measurement of the flow past the boat, which may vary depending on current speed and direction. Speed Through Water is most critical for anglers using downriggers, as it impacts the running depth of the down riggers. Speed Over Ground is optimal for navigation, as accurate destination times can be derived from this measurement. Humminbird® products allow for input and display of both sources.

**Structure** A general term for objects on the bottom that present a discontinuity and are a likely attractor for fish. This includes bottom contour features (drop-offs, humps, and holes), standing structure (stumps, timbers, brush piles), and a wide range of other potential objects (sunken boats, reefs).

**Surface Clutter** A phenomenon where sonar returns are reflected off of tiny objects near the surface of the water, including algae and even air bubbles. Typically, saltwater environments have significantly greater surface clutter than freshwater due to continuous wind and wave action that causes aeration at the surface.

**Target Separation** The measurement of minimum distance that a fishfinder needs to be able to recognize two very close objects as two distinct targets (i.e. two fish hanging very close, or a fish hanging very close to structure). Humminbird® fishfinders provide a very good 2 1/2 inches of target separation in shallower than 100 feet of depth. Target separation decreases as depth increases due to the need for longer Pulse Width to achieve greater depth. See *Pulse Width*.

**Thermoclines** Water layer(s) of distinctly different temperatures that create a sonar reflection due to the density of the differing water temperatures. Typically a thermocline will appear as a continuous band across the display at some distance above the bottom contour. Thermoclines are of interest to anglers because fish will suspend above or below the thermocline as they seek the optimum temperature and oxygen levels.

**Time Variable Gain (TVG)** A processing step applied to the sonar return to “normalize” the data so that objects of equal size (i.e. fish) appear to be the same size, even if they are separated by a good distance.

**Transducer** The transducer is part of the sonar system, which mounts on the boat and is in contact with the water, that converts the electrical energy from the transmitter into sound energy, and that forms the sonar beam in turn. Internally, the transducer consists of one or more piezo electric disks that expand by very minute amounts to create the sound wave. This element also works in reverse, converting the returned sound energy back into an electrical signal that the receiver interprets. See *SONAR*.

**Zoom** A feature that focuses on a smaller area of the bottom to provide enhanced resolution. With enhanced resolution, the angler can more easily see fish hanging in structure or multiple fish hanging close together.

**Zoom, Bottom Lock** Bottom Lock Zoom is a feature that focuses on a smaller area just above the bottom to provide enhanced resolution. Unlike regular zoom, it continuously graphs the bottom at a constant point on the display regardless of changes in depth. This “flattens” out the bottom contour, but is effective at showing fish on or near the bottom, and is preferred by many saltwater anglers.

## **GPS & Navigation Terms:**

**Acquisition Time** The length of time that a GPS receiver typically takes to determine a position from at least three satellites. Humminbird® GPS receivers provide very fast acquisition times (under one minute), permitting users to get out on the water faster.

**Altitude** The height measurement above sea level. Altitude is a measurement that can be provided by GPS.

**Bearing (BRG)** The direction to a destination waypoint measured in degrees from North (i.e. 321°, where 000° is North, 090° East, 180° is South, 270° is West).

**Chartplotter** A navigation device that shows Present Position on a Map, along with Tracks, Waypoints, and Routes. All Chartplotters are also considered Trackplotters.

**Cold Start** The procedure that a GPS receiver must perform when it does not have historical information regarding its current location. This procedure typically lasts for several minutes, and may be experienced upon first power up of the receiver, or if the receiver has been moved a great distance.

**Course Over Ground (COG)** The current direction the boat is traveling measured in degrees from North (i.e. 321°, where 000° is North, 090° East, 180° is South, 270° is West). When the Course Over Ground is equal to Bearing, the boat is said to be "On Course" and will arrive at the destination in the most efficient manner. COG is often confused with Heading. See *Heading*.

**Cross Track Error (XTE)** The straight-line distance of the boat from the intended Track. XTE measures how far the boat is off course and also triggers the Off Course Alarm. See *Track*.

**Differential GPS (DGPS)** A system used to improve the position accuracy of the Department of Defense GPS through the use of secondary "correction signals" broadcast from ground stations around the coastal United States and on some inland waterways. These correction signals are provided by the USCG and received by an auxiliary Differential Beacon Receiver (DBR) that connects to the GPS receiver. The advent of WAAS has largely negated the need for the added expense of a DBR in the United States.

**Distance To Go** The straight-line distance between Present Position and the Destination Waypoint. DTG and SOG (Speed Over Ground) are used to calculate Time To Go. See *Time to Go* and *Speed Over Ground*.

**Estimated Position Error (EPE)** A calculation that indicates the potential position inaccuracy the user may experience due to a variety of GPS factors which include satellite position in the sky, signal strength, and others factors.

**Fix Type** Indicates whether the GPS receiver is providing 2D fix or 3D fix. A 2D fix requires only three satellites and provides only latitude and longitude. A 3D fix requires four or more satellites, and provides latitude, longitude, and altitude.

**GPS (Global Positioning System)** GPS provides accurate position (latitude, longitude, altitude) information virtually anywhere on the earth through satellite technology and personal receivers on the ground. See *How GPS Works*.

**Heading** The direction the boat is pointing and is measured in degrees (i.e. 321°, where 000° is North, 090° East, 180° is South, 270° is West). Due to wind and waves, the boat is often traveling in a slightly different direction than it is heading, and therefore Heading is often confused with Course Over Ground. See *Course Over Ground*.

**Map Datum** Refers to a particular survey of the earth's surface that was referenced when creating a chart (i.e. WGS84). It is important to select the correct Map Datum setting in your fishfinder when comparing GPS position to a paper chart to avoid slight position inaccuracies. Almost all electronic charts use the WGS84 Map Datum and therefore, they do not require setting changes.

**MMC (Multi Media Card)** An MMC is a postage stamp-sized memory device used to store electronic data such a maps, waypoints, routes, and other information. MMC is a very rugged format suitable for the marine environment, but it is not waterproof. MMC is the same format that many digital cameras use. See *SD*.

**North, Magnetic** The principle reference point of the compass (i.e. North is 000°). Magnetic North relies on the earth's magnetic field to align a metal pointer generally towards True North. However, due to local variations in the earth's magnetic field around the globe, the difference between True North and Magnetic North can be greater than 10°. See *True North*.

**North, True** The principle reference point of the compass (i.e. North is 000°). True North uses the axis of the rotation of the earth as the reference for North and is constant for all points on the earth. Most GPS units default to True North as the setting. The GPS heading may vary from the boat compass heading because the compass uses Magnetic North. See *Magnetic North*.

**Present Position** The current location (latitude, longitude) determined by GPS. The Present Position is indicated on-screen by a directional boat icon if the boat is moving or a round symbol if the boat is stationary.

**Route** A series of waypoints linked together in a specific sequence to define a navigation path between two points, and saved in the fishfinder's memory. Routes are often used when frequently traveling between two or more locations because it is a faster and more accurate method than repeatedly selecting individual waypoints each time one travels through the same area. Routes consist of a Start Waypoint, an End Waypoint, and a series of waypoints in between. Users can begin navigation at the beginning, the end (to run the route in reverse) or at any waypoint in between. See *Waypoint*.

**SD (Secure Digital)** An SD card is virtually identical in function to an MMC; however, the speed at which information can be accessed is generally faster, the storage capacity is generally larger, and the card has security features which can be used to prevent extracting the data from the card. SD is the same format that many digital cameras use. See *MMC*.

**Selective Availability (SA)** A GPS system "feature" that can be implemented by the U.S. Department of Defense (DoD) to degrade the accuracy of GPS positioning information. With SA active, the GPS is accurate to within 100 meters 95% of the time. With SA inactive, the GPS is accurate to within 45 meters 95% of the time. Currently, SA is inactive and the consumer can enjoy the greater precision GPS provides; however, the DoD reserves the right to activate SA at any time.

**Speed Over Ground (SOG)** The measurement of the boat's progress across a given distance and the speed measurement provided by GPS. An alternate, Speed Through Water, is provided by a speed paddlewheel, and is the measurement of the flow past the boat, which may vary depending on current speed and direction. Speed Over Ground is optimal for navigation because accurate destination times can be derived from this measurement. Humminbird® products allow for input and display of both speed measurements.

**Time To Go (TTG)** The estimated time required to reach the destination waypoint. TTG is calculated using the SOG and DTG. See *SOG* and *DTG*.

**Track** A series of saved points that define the past path of the boat. These Track Points are saved at regular time intervals. Tracks are a useful and quick method to see where you've been, and an easy guide to follow to get you back to the starting point. Generally, all GPS units have a limited number of Track Points that can be saved before the unit runs out of memory and begins erasing the first track points saved. Because of this, the user can adjust the Track Point Interval menu to increase the amount of time between when points are saved, and thus extend the distance covered by a track. Tracks can also be permanently saved to memory and re-displayed at the user's option.

**Track Line (TRK)** The planned line of travel between two waypoints, and it represents the most efficient path between the two points because it is a straight line. The TRK is measured in degrees (i.e. 321°, where 000° is North, 090° East, 180° is South, 270° is West). See *Cross Track Error* and *Course Over Ground*.

**Trackplotter** A navigation device that shows Present Position, along with Track, Waypoint, and Routes, but NO MAP in the background. See *Chartplotter*.

**Trolling Grid** A Humminbird® feature that displays a precise reference grid around a waypoint. This grid is used as a guide pattern for trolling around a specific area to assure a more efficient and complete coverage of that area.

**UTC (Universal Time Constant)** UTC is the “standard time” used in navigation and is the local time in Greenwich England. (UTC is equivalent to Greenwich Mean Time (GMT)).

**WAAS (Wide Area Augmentation System)** WAAS is complementary technology to GPS that provides enhanced accuracy through correction signals broadcast from Federal Aviation Administration WAAS satellites stationed over the USA. These secondary signals are automatically received by the standard Humminbird® GPS Receiver. With WAAS signal, GPS accuracy is improved to within 3 meters 95% of the time. Outside the United States, regional governmental coalitions have created similar systems such as EGNOS (Europe) and MSAS (Japan).

**Waypoint** The saved location (latitude, longitude) of a point of interest that is stored in a GPS receiver’s memory. This can include a marker buoy, dock, fishing hole, or anywhere else the user may want to return to. Humminbird® products offer the ability to name and assign a symbol to the saved location. Depth, Date, and Time of Day when the waypoint was created is also saved.

**Waypoint Target** A Humminbird® feature that displays a precise “bull’s eye” around a selected waypoint. This bull’s eye is used to easily monitor boat position relative to a waypoint, and is useful for fishing over submerged structure. With Waypoint Targets, a quick look at the screen lets you know how far off the waypoint the boat has drifted.

## Contact Humminbird®

Contact the Humminbird® Customer Resource Center  
in any of the following ways:

By Telephone:

(Monday - Friday 8:00 a.m. to 4:30 p.m. Central Standard Time):

**1-800-633-1468**

By e-mail:

(typically we respond to your e-mail within three business days):

**service@humminbird.com**

For direct shipping, our address is:

**Humminbird**

Service Department

678 Humminbird Lane

Eufaula, AL 36027 USA



**HUMMINBIRD®**