

Шкаф 80 (также применяется как витрина)
(Wall cupboard 80 (cabinet-showcase 80))

Код ТН ВЭД ЕАЭС

9403 40 100 0
9403 90 300 0



отрезать
и приклеить

800	690	298

корпус - 70Ш80Б1632

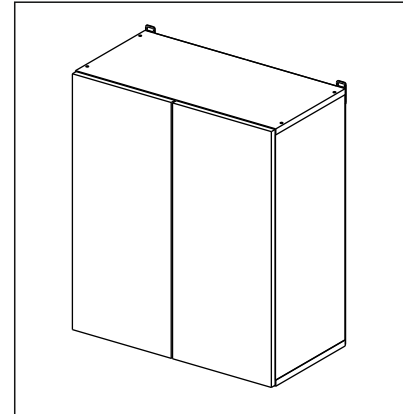
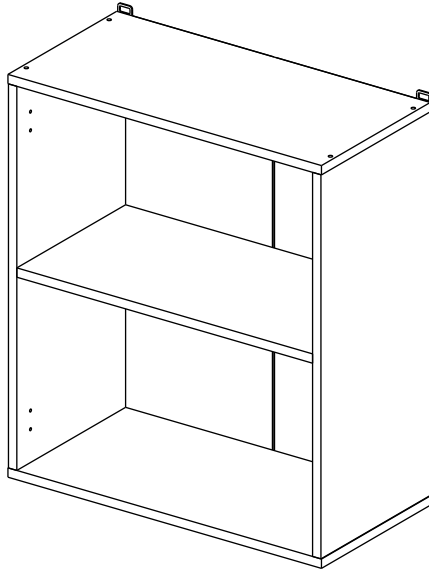

Комплектовочная ведомость / Set package sheet

Наименование	Description	Цвет детали/Décor		Размер / Size, mm	Кол-во/ Quantity	№
Фурнитура	Furniture/Cabinetry	-	-	-	1	-
Бок левый	Side left	Белый	White	658x294	1	1
Бок правый	Side right	Белый	White	658x294	1	2
Крышка	Top	Белый	White	800x294	2	3
Полка	Shelves	Белый	White	766x250	1	4
Соед. Элемент	Connecting back element	Белый	White	658 мм	1	7

2x









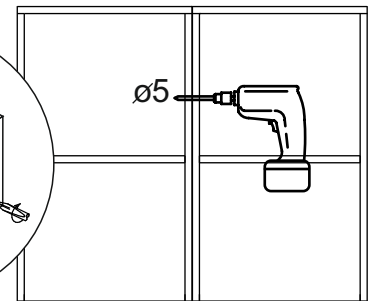
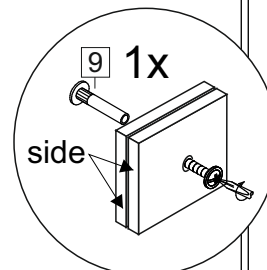

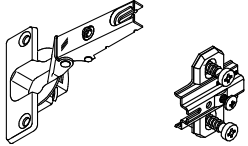
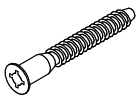
Продается отдельно/Sold separately

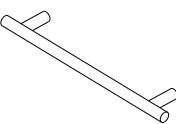
Package door/ panel	Створка	Door	см упак/look at the package		Размер / Size, mm	Кол-во/ Quantity	№
	ХДФ	Back element	Белый	White	686x396	1	5
	Ручка	Hadle	-	-	-	1	-
	Заглушка только для ЛЮКС, КАМЕЛИЯ/Cap only for Lux, Kameliya D35 mm					2	-

***Внимание!!! Attention!!! Cabinet Handles**

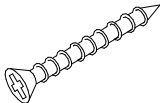
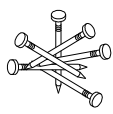
Europe, Polonez, Loft, Lux - C36
Princess, Kameliya - FS 186 096
Vintage - СПА5
Eva - K17

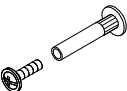

91	A	5	7*50	39	*		53		
									
4 x			8 x		4 x	2 x	2 x		
3		6	6,3*10,5	18	3,5*15	10	3,5*25	48	2*20
									
2 x			8 x		8 x		8 x	20 x	
72		71		9		15			
									
8 x		4 x		1 x		1 x			

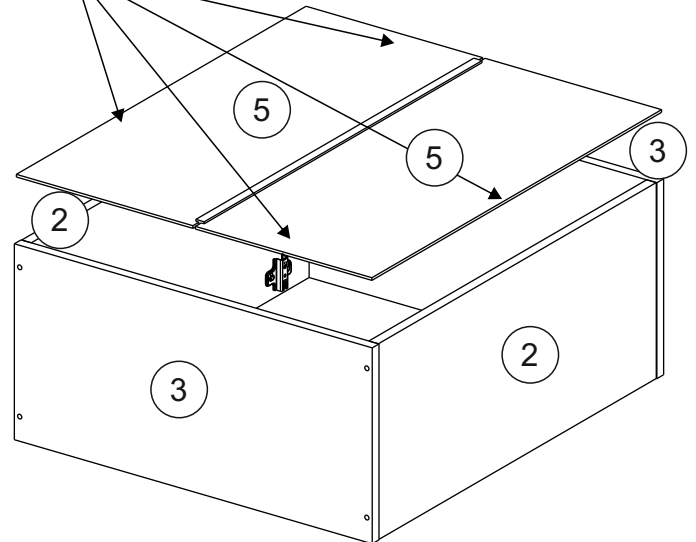
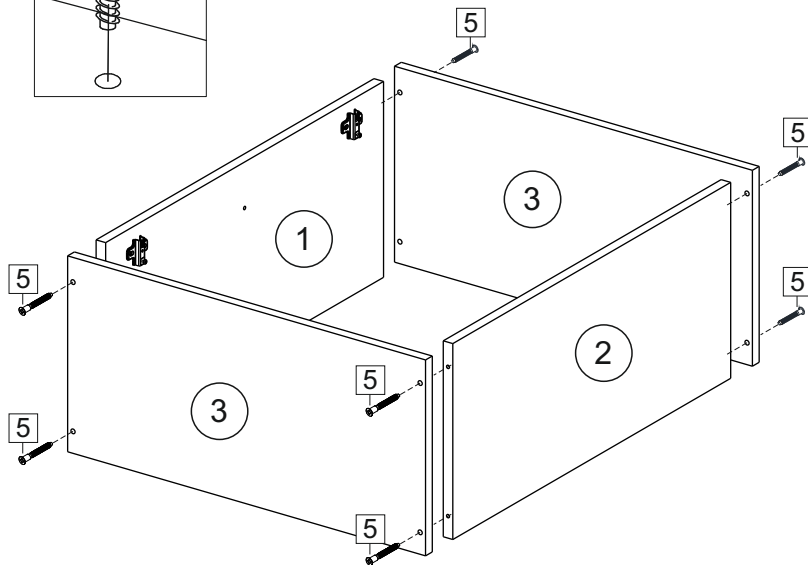
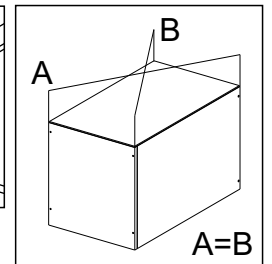
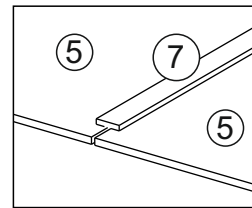
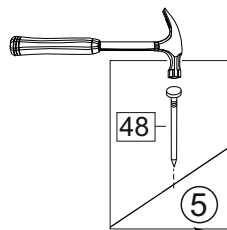
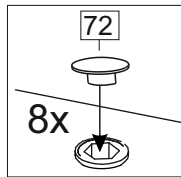
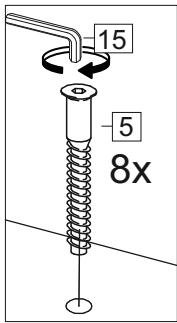
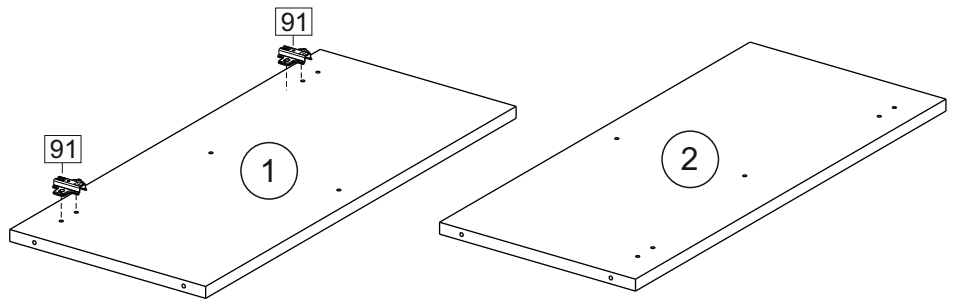
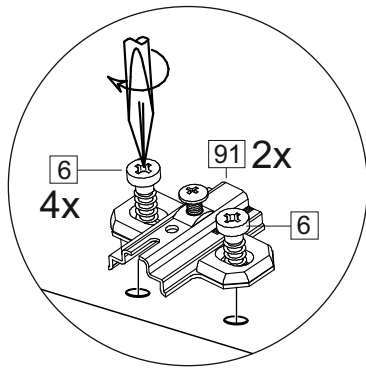

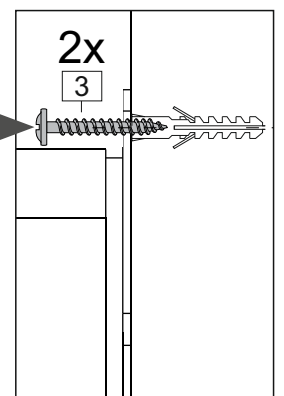
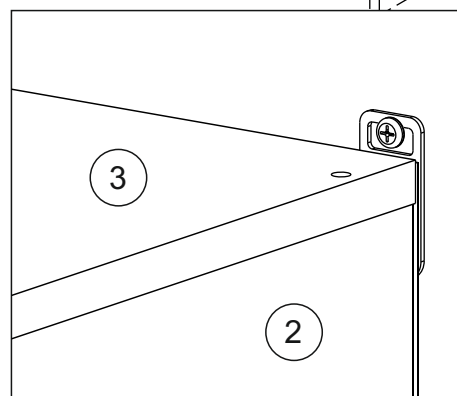
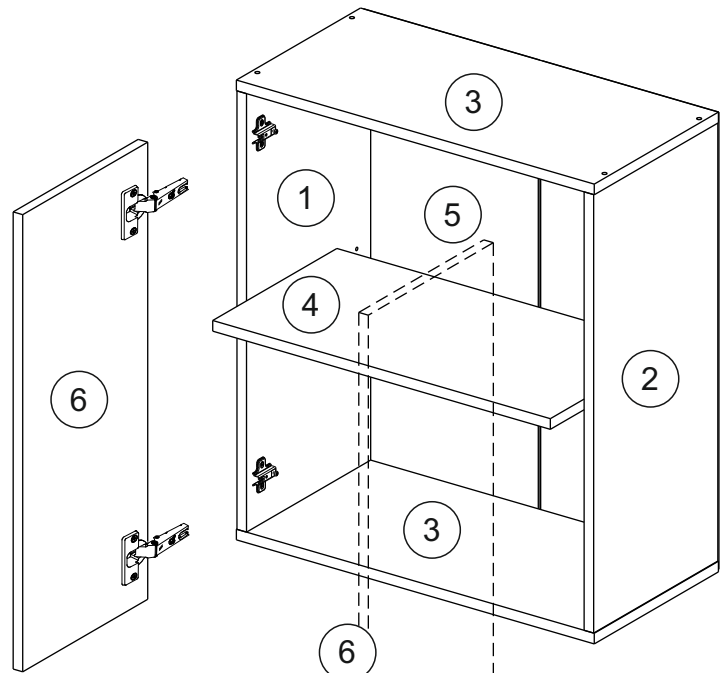
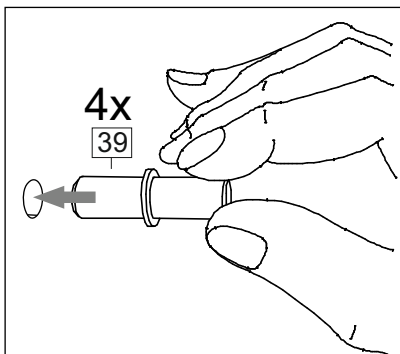
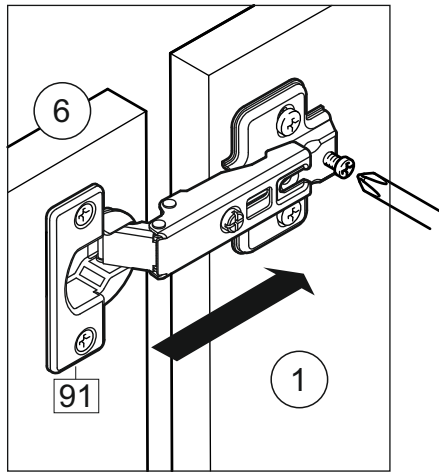
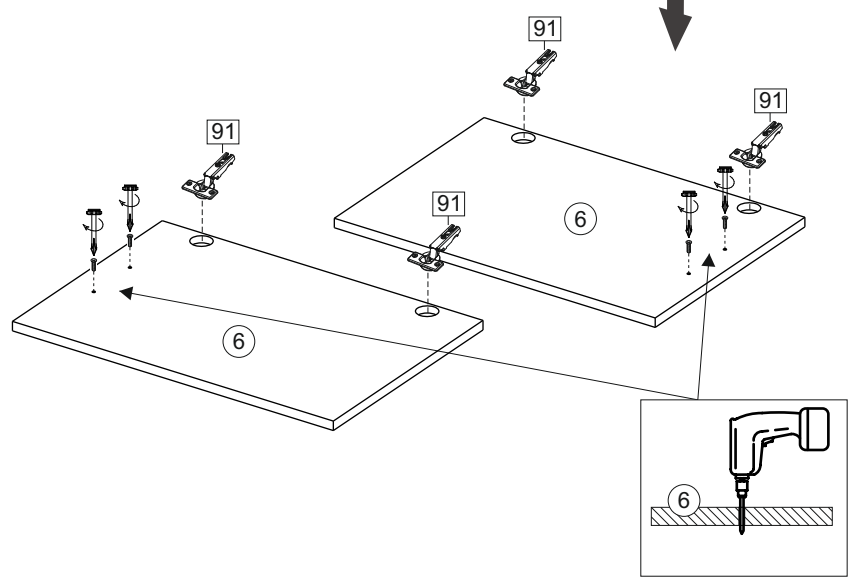
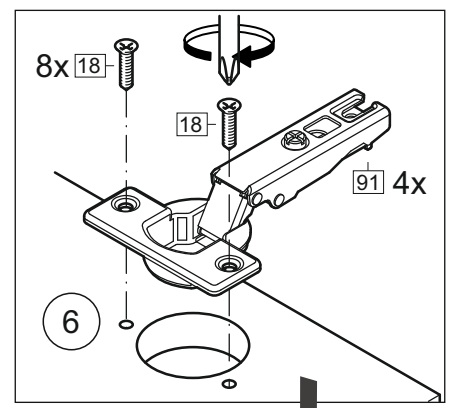
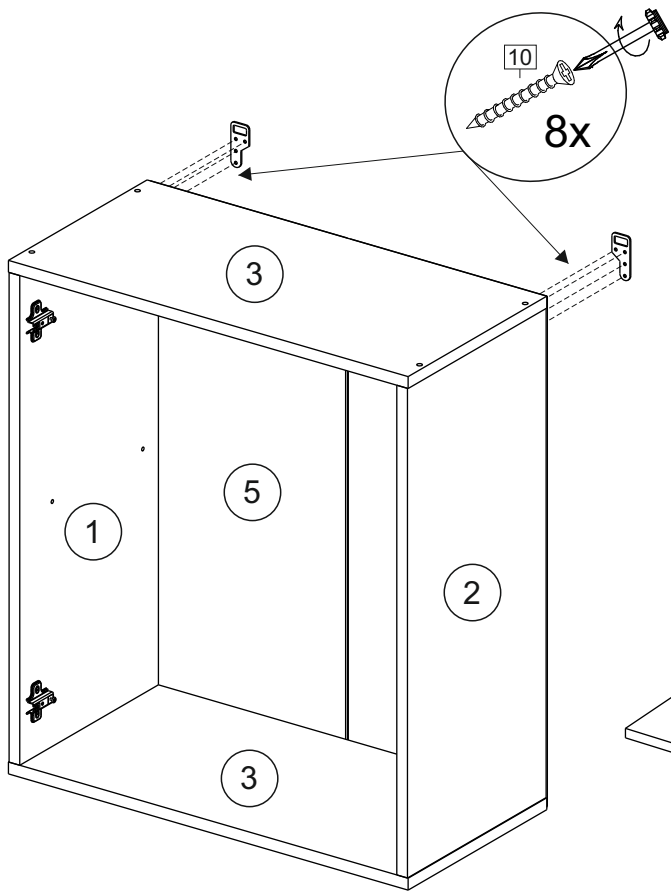

(PL) Instrukcja montażu

(CZ) Návod k montáži

(D) Montageanleitung

(GB) Assembly instruction

(F) Model d'emploi

(HU) Szerelési útmutató

(I) Istruzione di montaggio

(NL) Handleiding voor de montage



(RU) Инструкция по монтажу

(RO) Instrucțiuni de montare

(SK) Návod k montáži

(TR) Montaj talimatı

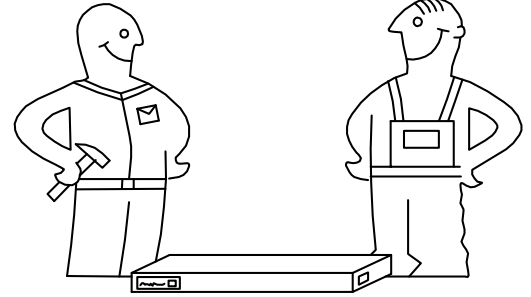
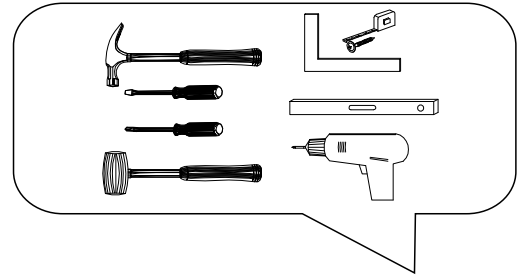

⚠ Uwaga • Upozornění • Achtung • Attention • Caution • Figyelem ⚠ Attenzione • Opgelet • Внимание • Atenție • Upozornenie • Dikkat	
PL	Czyszczenie należy wykonać wyłącznie za pomocą ściereczki lub lekko nawilżonego ręcznika. Nie stosować środków czyszczących do szorowania.
CZ	Čistění je nutné vykonávat výhradně pomocí utěrky nebo lehce navlhčeného ručníku. Nepoužívejte čističí prostředky obsahující abrazivní částice.
D	Bitte nur mit einem Staubtuch oder leicht feuchtem Lappen reinigen. Keine scheuernden Putzmittel verwenden.
GB	Please only clean with a duster or a damp cloth. Do not use any abrasive cleaners.
F	Le nettoyage se fait uniquement à l'aide d'un torchon ou d'une serviette légèrement mouillée.
HU	A tisztítás kizárólag törülőruha vagy enyhén nedvesített törölköző segítségével végezhető. Súroló hatású tisztítószereket nem szabad használni.
I	Pulire esclusivamente con un panno o un asciugamano umido.
NL	Reinig alleen met een stofdoek of een lichtjes vochtige doek. Gebruik geen schurende poetsmiddelen.
RU	Очищайте от пыли тряпкой или слегка влажной ветошью. Не допускается применение чистящих средств, не предназначенных для ухода за мебелью.
RO	Curățarea trebuie efectuată numai cu o cârpă sau cu un prosop ușor umezit. Nu utilizați agenți de curățare abrazivi.
SK	Čistení je nutné vykonávať výhradne pomocí utierky alebo ľahko zvlhnutým ručníkom. Nepoužívajte čistiace prostriedky obsahujúce abrazívne častice.
TR	Lütfen sadece bir toz bezilye veya hafif nemli yumuşak bir bezle siliniz. Aşındırıcı temizlik malzemeleri kullanmayınız.

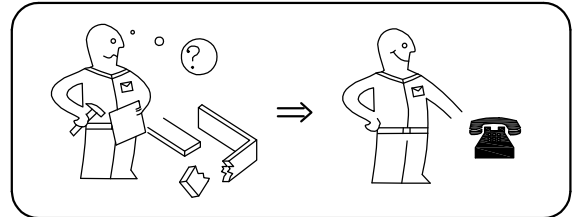
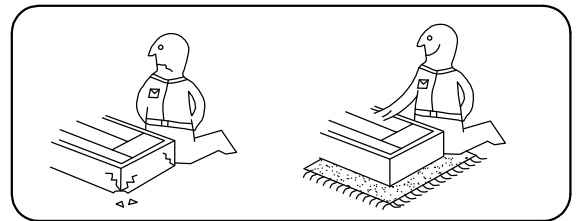

**Karta serwisowa • Servisní list • Service Karte • Service card • Carte de service • Szervizkártya
Scheda di servizio • Service kaart • Сервисная карта • Fisa service • Servisný list • Servis karti**

