

Version 1.0

Published August 2020

Copyright©2020 ASRock INC. All rights reserved.



## Copyright Notice:

No part of this documentation may be reproduced, transcribed, transmitted, or translated in any language, in any form or by any means, except duplication of documentation by the purchaser for backup purpose, without written consent of ASRock Inc.

Products and corporate names appearing in this documentation may or may not be registered trademarks or copyrights of their respective companies, and are used only for identification or explanation and to the owners' benefit, without intent to infringe.

## Disclaimer:

Specifications and information contained in this documentation are furnished for informational use only and subject to change without notice, and should not be construed as a commitment by ASRock. ASRock assumes no responsibility for any errors or omissions that may appear in this documentation.

With respect to the contents of this documentation, ASRock does not provide warranty of any kind, either expressed or implied, including but not limited to the implied warranties or conditions of merchantability or fitness for a particular purpose.

In no event shall ASRock, its directors, officers, employees, or agents be liable for any indirect, special, incidental, or consequential damages (including damages for loss of profits, loss of business, loss of data, interruption of business and the like), even if ASRock has been advised of the possibility of such damages arising from any defect or error in the documentation or product.



This device complies with Part 15 of the FCC Rules. Operation is subject to the following two conditions:

- (1) this device may not cause harmful interference, and
- (2) this device must accept any interference received, including interference that may cause undesired operation.

## CALIFORNIA, USA ONLY

The Lithium battery adopted on this motherboard contains Perchlorate, a toxic substance controlled in Perchlorate Best Management Practices (BMP) regulations passed by the California Legislature. When you discard the Lithium battery in California, USA, please follow the related regulations in advance.

“Perchlorate Material-special handling may apply, see [www.dtsc.ca.gov/hazardouswaste/perchlorate](http://www.dtsc.ca.gov/hazardouswaste/perchlorate)”

**ASRock Website: <http://www.asrock.com>**

## AUSTRALIA ONLY

Our goods come with guarantees that cannot be excluded under the Australian Consumer Law. You are entitled to a replacement or refund for a major failure and compensation for any other reasonably foreseeable loss or damage caused by our goods. You are also entitled to have the goods repaired or replaced if the goods fail to be of acceptable quality and the failure does not amount to a major failure. If you require assistance please call ASRock Tel : +886-2-28965588 ext.123 (Standard International call charges apply)

The terms HDMI® and HDMI High-Definition Multimedia Interface, and the HDMI logo are trademarks or registered trademarks of HDMI Licensing LLC in the United States and other countries.



# Motherboard Layout

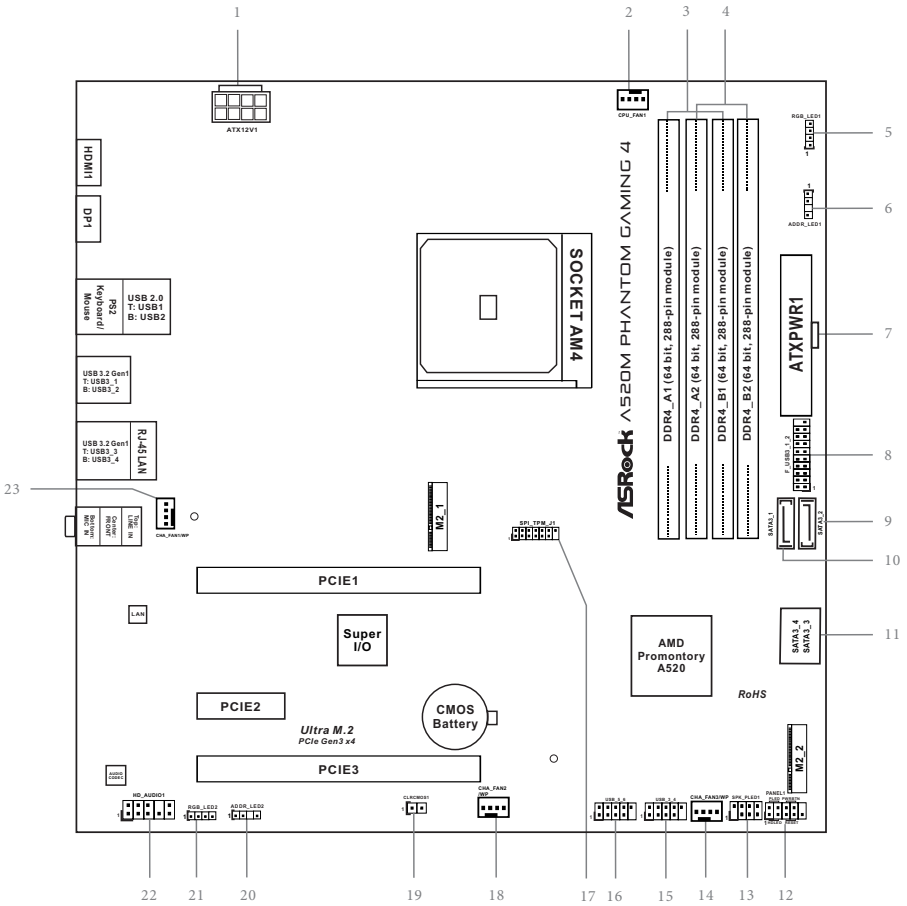

No.	Description
1	8 pin 12V Power Connector (ATX12V1)
2	CPU Fan Connector (CPU_FAN1)
3	2 x 288-pin DDR4 DIMM Slots (DDR4_A1, DDR4_B1)
4	2 x 288-pin DDR4 DIMM Slots (DDR4_A2, DDR4_B2)
5	RGB LED Header (RGB_LED1)
6	Addressable LED Header (ADDR_LED1)
7	ATX Power Connector (ATXPWR1)
8	USB 3.2 Gen1 Header (F_USB3_1_2)
9	SATA3 Connector (SATA3_2)
10	SATA3 Connector (SATA3_1)
11	SATA3 Connector (SATA3_4)(Upper), SATA3 Connector (SATA3_3)(Lower)
12	System Panel Header (PANEL1)
13	Power LED and Speaker Header (SPK_PLED1)
14	Chassis/Water Pump Fan Connector (CHA_FAN3/WP)
15	USB 2.0 Header (USB_3_4)
16	USB 2.0 Header (USB_5_6)
17	SPI TPM Header (SPI_TPM_J1)
18	Chassis/Water Pump Fan Connector (CHA_FAN2/WP)
19	Clear CMOS Jumper (CLRCMOS1)
20	Addressable LED Header (ADDR_LED2)
21	RGB LED Header (RGB_LED2)
22	Front Panel Audio Header (HD_AUDIO1)
23	Chassis/Water Pump Fan Connector (CHA_FAN1/WP)

## I/O Panel

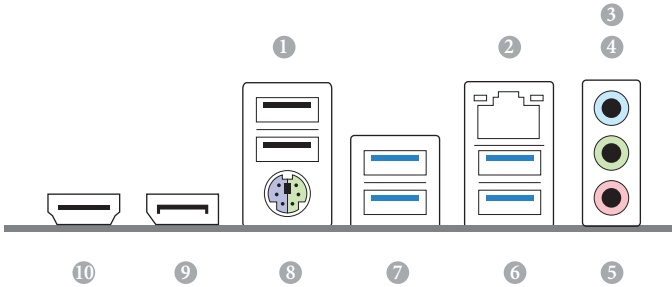

No.	Description	No.	Description
1	USB 2.0 Ports (USB_12)*	6	USB 3.2 Gen1 Ports (USB3_34)
2	LAN RJ-45 Port**	7	USB 3.2 Gen1 Ports (USB3_12)
3	Line In (Light Blue)***	8	PS/2 Mouse/Keyboard Port
4	Front Speaker (Lime)***	9	DisplayPort 1.4
5	Microphone (Pink)***	10	HDMI Port

\* Please note that the USB\_2 consumes auxiliary power (+5VSB) while the other USB ports consume DUAL Power (+5VDUAL). The USB\_2 is optimal for connecting the USB Type speaker and headset..

\*\* There are two LEDs on each LAN port. Please refer to the table below for the LAN port LED indications.

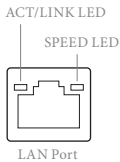

Activity / Link LED		Speed LED	
Status	Description	Status	Description
Off	No Link	Off	10Mbps connection
Blinking	Data Activity	Orange	100Mbps connection
On	Link	Green	1Gbps connection

\*\*\* Function of the Audio Ports in 7.1-channel Configuration:

Port	Function
Light Blue (Rear panel)	Rear Speaker Out
Lime (Rear panel)	Front Speaker Out
Pink (Rear panel)	Central /Subwoofer Speaker Out
Lime (Front panel)	Side Speaker Out

# Chapter 1 Introduction

Thank you for purchasing ASRock A520M Phantom Gaming 4 motherboard, a reliable motherboard produced under ASRock's consistently stringent quality control. It delivers excellent performance with robust design conforming to ASRock's commitment to quality and endurance.



*Because the motherboard specifications and the BIOS software might be updated, the content of this documentation will be subject to change without notice. In case any modifications of this documentation occur, the updated version will be available on ASRock's website without further notice. If you require technical support related to this motherboard, please visit our website for specific information about the model you are using. You may find the latest VGA cards and CPU support list on ASRock's website as well. ASRock website <http://www.asrock.com>.*

## 1.1 Package Contents

- ASRock A520M Phantom Gaming 4 Motherboard (Micro ATX Form Factor)
- ASRock A520M Phantom Gaming 4 Quick Installation Guide
- ASRock A520M Phantom Gaming 4 Support CD
- 1 x I/O Panel Shield
- 2 x Serial ATA (SATA) Data Cables (Optional)
- 2 x Screws for M.2 Sockets (Optional)

## 1.2 Specifications

- Platform**
- Micro ATX Form Factor
  - Solid Capacitor design
  - 2oz Copper PCB

- CPU**
- Supports 3<sup>rd</sup> Gen AMD AM4 Ryzen™ / future AMD Ryzen™ Processors (3000 and 4000 Series Processors)\*
- \* Not compatible with AMD Ryzen™ 5 3400G and Ryzen™ 3 3200G.
- Digi Power design
  - 8 Power Phase design

- Chipset**
- AMD A520

- Memory**
- Dual Channel DDR4 Memory Technology
  - 4 x DDR4 DIMM Slots
  - AMD Ryzen series CPUs (Matisse) support DDR4 4533+(OC)/4466(OC)/4400(OC)/4333(OC)/4266(OC)/4200(OC)/4133(OC)/4000(OC)/3866(OC)/3800(OC)/3733(OC)/3600(OC)/3466(OC)/3200/2933/2667/2400/2133 ECC & non-ECC, un-buffered memory\*
  - AMD Ryzen series APUs (Renoir) support DDR4 4733+(OC)/4666(OC)/4600(OC)/4533(OC)/4466(OC)/4400(OC)/4333(OC)/4266(OC)/4200(OC)/4133(OC)/4000(OC)/3866(OC)/3800(OC)/3733(OC)/3600(OC)/3466(OC)/3200/2933/2667/2400/2133 ECC & non-ECC, un-buffered memory\*
- \* Please refer to Memory Support List on ASRock's website for more information. (<http://www.asrock.com/>)
- \* Please refer to page 21 for DDR4 UDIMM maximum frequency support.
- Max. capacity of system memory: 128GB
  - Supports Extreme Memory Profile (XMP) memory modules
  - 15μ Gold Contact in DIMM Slots

- Expansion Slot**
- 2 x PCI Express 3.0 x16 Slots (PCIe1: x16 mode; PCIe3: x2 mode)\*
- \* Supports NVMe SSD as boot disks
- 1 x PCI Express 3.0 x1 Slot



**Graphics**

- Integrated AMD Radeon™ Vega Series Graphics in Ryzen Series APU\*
- \* Actual support may vary by CPU
- DirectX 12, Pixel Shader 5.0
- Shared memory default 2GB. Max Shared memory supports up to 16GB.
- \* The Max shared memory 16GB requires 32GB system memory installed.
- Dual graphics output: support HDMI and DisplayPort 1.4 ports by independent display controllers
- Supports HDMI 2.1 with max. resolution up to 4K x 2K (4096x2160) @ 60Hz
- Supports DisplayPort 1.4 with max. resolution up to 5K (5120x2880)@120Hz
- Supports Auto Lip Sync, Deep Color (12bpc), xvYCC and HBR (High Bit Rate Audio) with HDMI 2.1 Port (Compliant HDMI monitor is required)
- Supports HDR (High Dynamic Range) with HDMI 2.1
- Supports HDCP 2.3 with HDMI 2.1 and DisplayPort 1.4 Ports
- Supports 4K Ultra HD (UHD) playback with HDMI 2.1 and DisplayPort 1.4 Ports
- Supports Microsoft PlayReady®

**Audio**

- 7.1 CH HD Audio (Realtek ALC 887/897 Audio Codec)
- Supports Surge Protection

**LAN**

- PCIE x1 Gigabit LAN 10/100/1000 Mb/s
- Realtek RTL8111H
- Supports Wake-On-LAN
- Supports Lightning/ESD Protection
- Supports Energy Efficient Ethernet 802.3az
- Supports PXE

## Rear Panel I/O

- 1 x PS/2 Mouse/Keyboard Port
- 1 x HDMI Port
- 1 x DisplayPort 1.4
- 4 x USB 3.2 Gen1 Ports (Supports ESD Protection)
- 2 x USB 2.0 Ports (Supports ESD Protection)
- 1 x RJ-45 LAN Port with LED (ACT/LINK LED and SPEED LED)
- HD Audio Jacks: Line in / Front Speaker / Microphone

## Storage

- 4 x SATA3 6.0 Gb/s Connectors, support RAID (RAID 0, RAID 1 and RAID 10), NCQ, AHCI and Hot Plug\*
- \* M2\_2 and SATA3\_3\_4 share lanes. If either one of them is in use, the other one will be disabled.
- 1 x Ultra M.2 Socket (M2\_1), supports M Key type 2280 M.2 PCI Express module up to Gen3 x4 (32 Gb/s)\*\*
- 1 x M.2 Socket (M2\_2), supports M Key type 2280 M.2 SATA3 6.0 Gb/s module and M.2 PCI Express module up to Gen3 x2 (16 Gb/s)\*\*
- \*\* Supports NVMe SSD as boot disks
- \*\* Supports ASRock U.2 Kit

## Connector

- 1 x SPI TPM Header
- 1 x Power LED and Speaker Header
- 2 x RGB LED Headers
- \* Support in total up to 12V/3A, 36W LED Strip
- 2 x Addressable LED Headers
- \* Support in total up to 5V/3A, 15W LED Strip
- 1 x CPU Fan Connector (4-pin)
- \* The CPU Fan Connector supports the CPU fan of maximum 1A (12W) fan power.
- 3 x Chassis/Water Pump Fan Connectors (4-pin) (Smart Fan Speed Control)
- \* The Chassis/Water Pump Fan supports the water cooler fan of maximum 2A (24W) fan power.
- \* CHA\_FAN1/WP, CHA\_FAN2/WP and CHA\_FAN3/WP can auto detect if 3-pin or 4-pin fan is in use.
- 1 x 24 pin ATX Power Connector
- 1 x 8 pin 12V Power Connector
- 1 x Front Panel Audio Connector

- 2 x USB 2.0 Headers (Support 4 USB 2.0 ports) (Supports ESD Protection)
- 1 x USB 3.2 Gen1 Header (Supports 2 USB 3.2 Gen1 port) (Supports ESD Protection)

#### **BIOS Feature**

- AMI UEFI Legal BIOS with GUI support
- Supports “Plug and Play”
- ACPI 5.1 compliance wake up events
- Supports jumperfree
- SMBIOS 2.3 support
- CPU, CPU VDDCR\_SOC, DRAM, +1.8VSB, Voltage Multi-adjustment

#### **Hardware Monitor**

- Temperature Sensing: CPU, Chassis/Water Pump Fans
- Fan Tachometer: CPU, Chassis/Water Pump Fans
- Quiet Fan (Auto adjust chassis fan speed by CPU temperature): CPU, Chassis/Water Pump Fans
- Fan Multi-Speed Control: CPU, Chassis/Water Pump Fans
- Voltage monitoring: +12V, +5V, +3.3V, CPU Vcore, CPU VDDCR\_SOC, DRAM, VPPM, +1.8V

#### **OS**

- Microsoft® Windows® 10 64-bit

#### **Certifica- tions**

- FCC, CE
- ErP/EuP ready (ErP/EuP ready power supply is required)

\* For detailed product information, please visit our website: <http://www.asrock.com>



Please realize that there is a certain risk involved with overclocking, including adjusting the setting in the BIOS, applying Untied Overclocking Technology, or using third-party overclocking tools. Overclocking may affect your system's stability, or even cause damage to the components and devices of your system. It should be done at your own risk and expense. We are not responsible for possible damage caused by overclocking.

---

## Chapter 2 Installation

This is a Micro ATX form factor motherboard. Before you install the motherboard, study the configuration of your chassis to ensure that the motherboard fits into it.

### Pre-installation Precautions

Take note of the following precautions before you install motherboard components or change any motherboard settings.

- Make sure to unplug the power cord before installing or removing the motherboard. Failure to do so may cause physical injuries to you and damages to motherboard components.
- In order to avoid damage from static electricity to the motherboard's components, NEVER place your motherboard directly on a carpet. Also remember to use a grounded wrist strap or touch a safety grounded object before you handle the components.
- Hold components by the edges and do not touch the ICs.
- Whenever you uninstall any components, place them on a grounded anti-static pad or in the bag that comes with the components.
- When placing screws to secure the motherboard to the chassis, please do not over-tighten the screws! Doing so may damage the motherboard.

## 2.1 Installing the CPU



*Unplug all power cables before installing the CPU.*

1

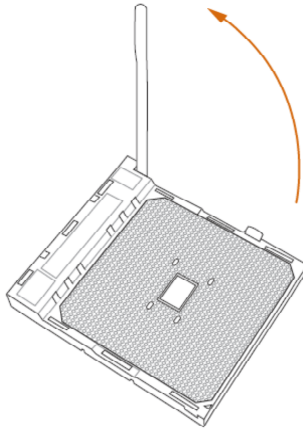

2

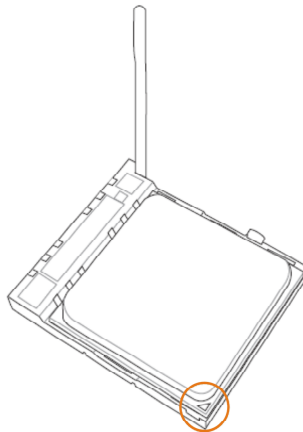

3

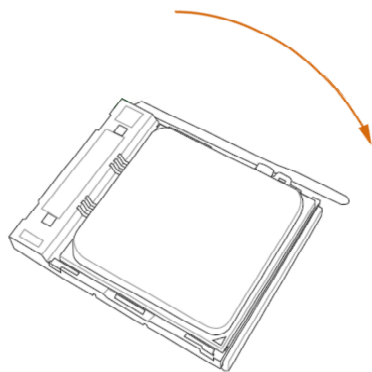

## 2.2 Installing the CPU Fan and Heatsink

After you install the CPU into this motherboard, it is necessary to install a larger heatsink and cooling fan to dissipate heat. You also need to spray thermal grease between the CPU and the heatsink to improve heat dissipation. Make sure that the CPU and the heatsink are securely fastened and in good contact with each other.



*Please turn off the power or remove the power cord before changing a CPU or heatsink.*

### Installing the CPU Box Cooler SR1

1

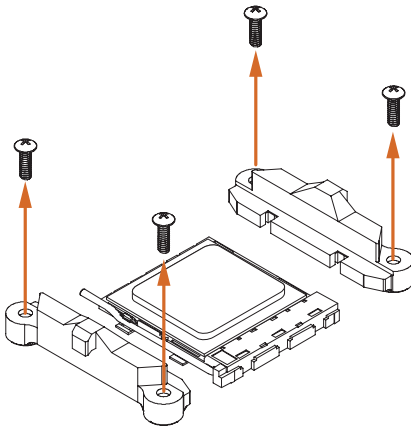

2

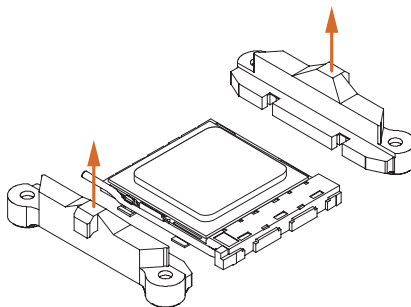

3

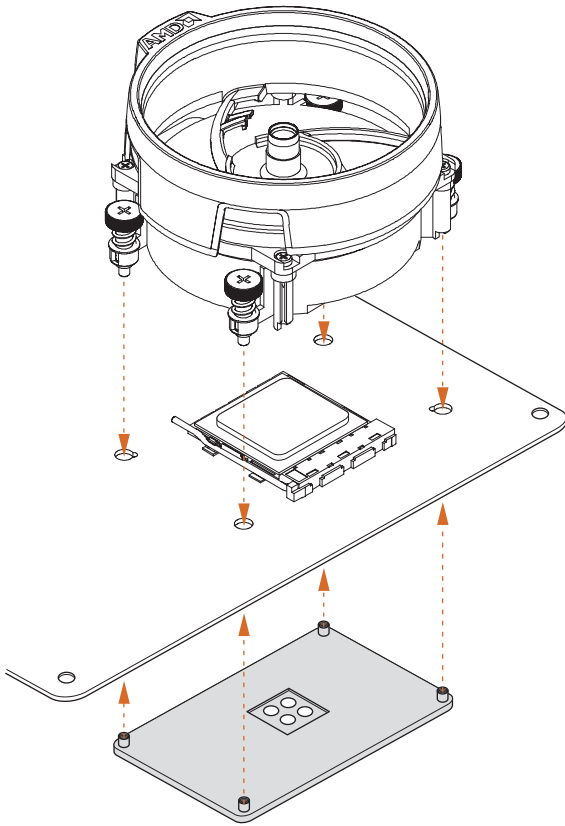

4

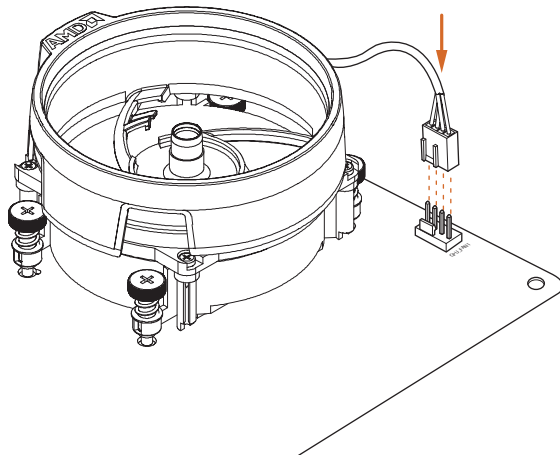



## Installing the AM4 Box Cooler SR2

1

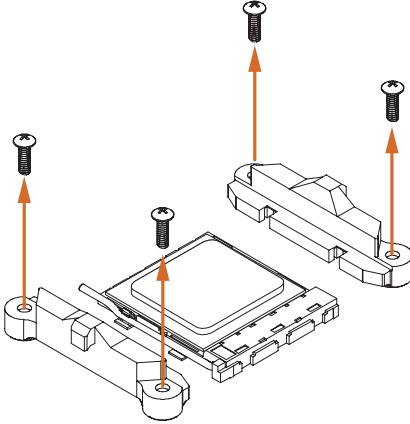

2

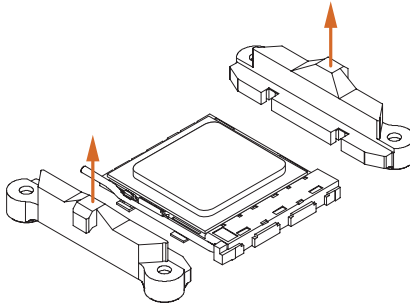

3

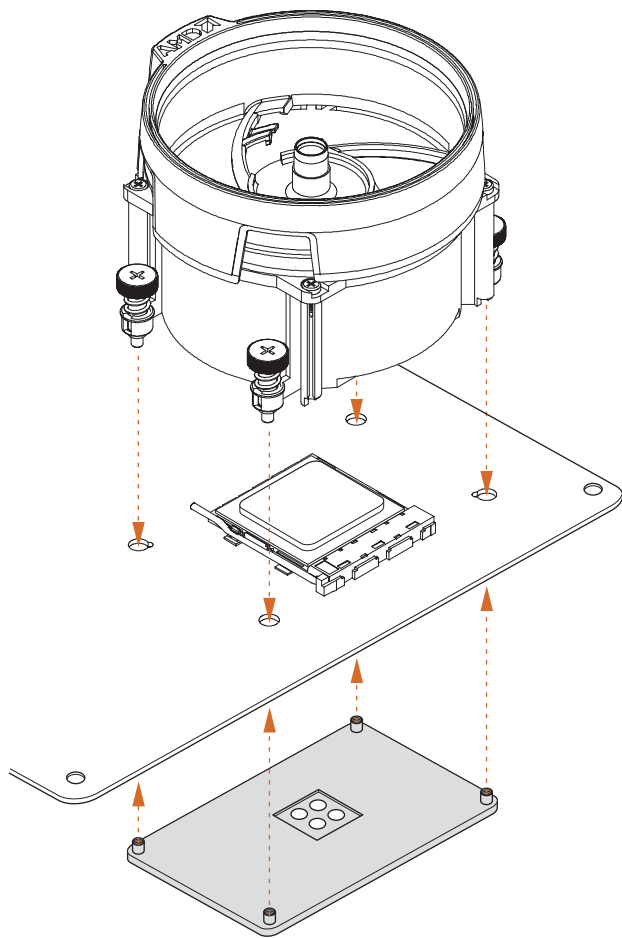

4

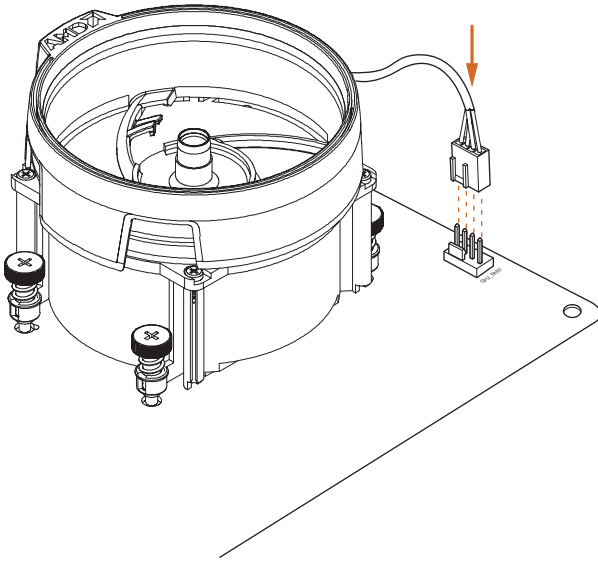

\*The diagrams shown here are for reference only. The headers might be in a different position on your motherboard.

## Installing the AM4 Box Cooler SR3

1

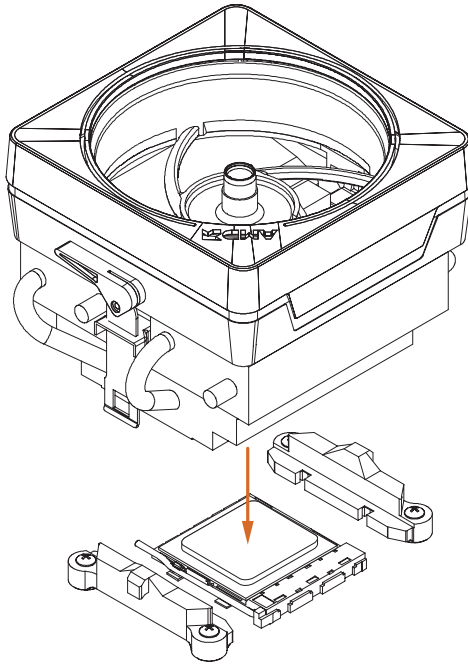

2

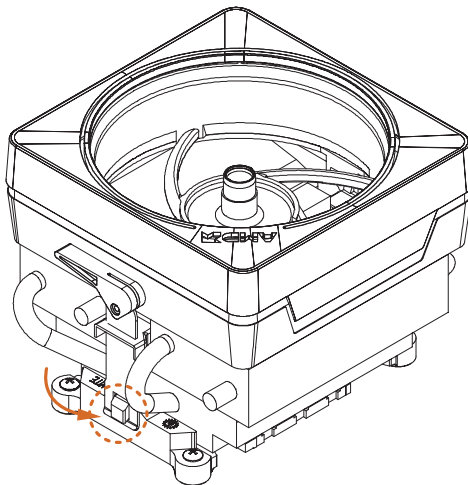

3

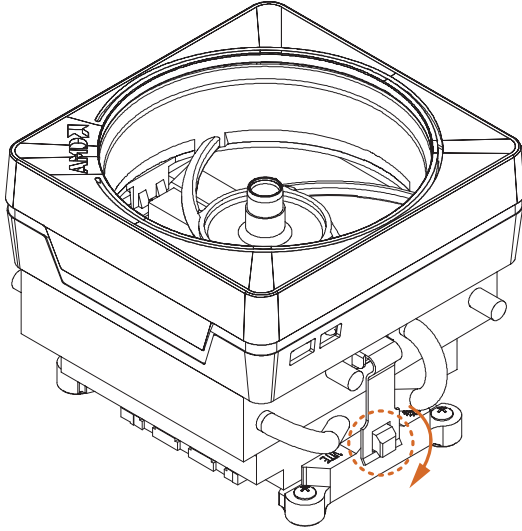

4

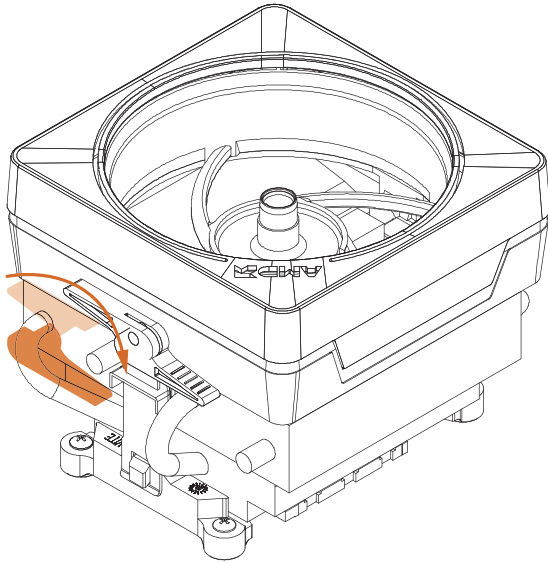

5

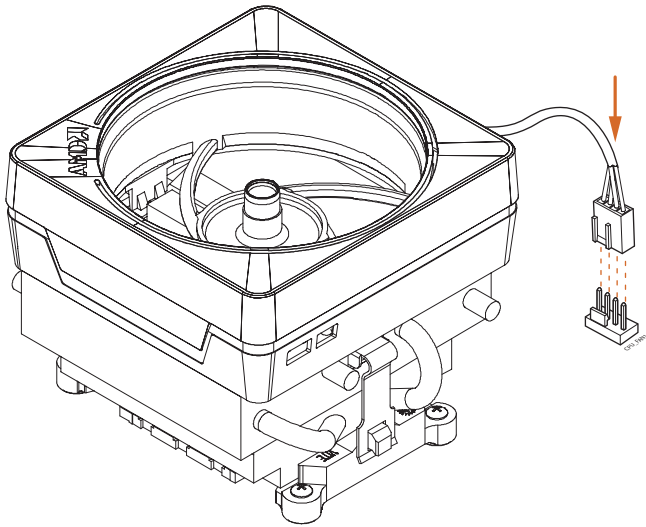

6

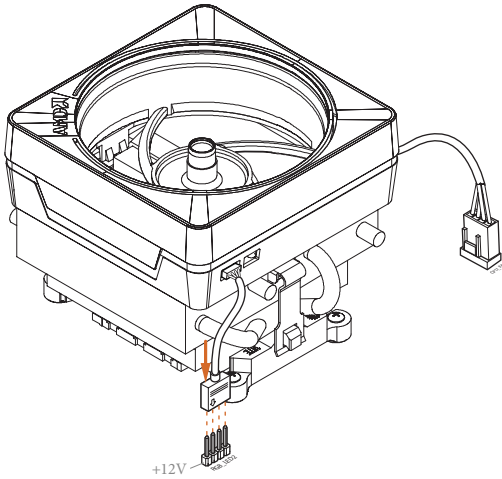

\*The diagrams shown here are for reference only. The headers might be in a different position on your motherboard.

## 2.3 Installing Memory Modules (DIMM)

This motherboard provides four 288-pin DDR4 (Double Data Rate 4) DIMM slots, and supports Dual Channel Memory Technology.



1. For dual channel configuration, you always need to install identical (the same brand, speed, size and chip-type) DDR4 DIMM pairs.
2. It is unable to activate Dual Channel Memory Technology with only one or three memory module installed.
3. It is not allowed to install a DDR, DDR2 or DDR3 memory module into a DDR4 slot; otherwise, this motherboard and DIMM may be damaged.
4. We suggest that you install the memory modules on DDR4\_A2 and DDR4\_B2 first for better DRAM compatibility on 2 DIMMs configuration.

### AMD non-XMP Memory Frequency Support

Ryzen Series CPUs (Matisse):

UDIMM Memory Slot				Frequency
A1	A2	B1	B2	(Mhz)
-	SR	-	-	3200
-	DR	-	-	3200
-	SR	-	SR	3200
-	DR	-	DR	3200
SR	SR	SR	SR	2933
SR/DR	DR	SR/DR	DR	2667
SR/DR	SR/DR	SR/DR	SR/DR	2667

Ryzen Series APUs (Renoir):

UDIMM Memory Slot				Frequency
A1	A2	B1	B2	(Mhz)
-	SR	-	-	3200
-	DR	-	-	3200
-	SR	-	SR	3200
-	DR	-	DR	3200
SR	SR	SR	SR	2933
SR/DR	DR	SR/DR	DR	2667
SR/DR	SR/DR	SR/DR	SR/DR	2667

SR: Single rank DIMM, 1Rx4 or 1Rx8 on DIMM module label

DR: Dual rank DIMM, 2Rx4 or 2Rx8 on DIMM module label





The DIMM only fits in one correct orientation. It will cause permanent damage to the motherboard and the DIMM if you force the DIMM into the slot at incorrect orientation.

1

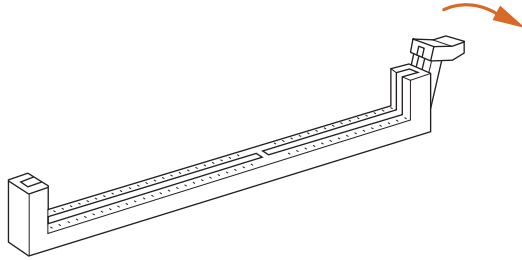

2

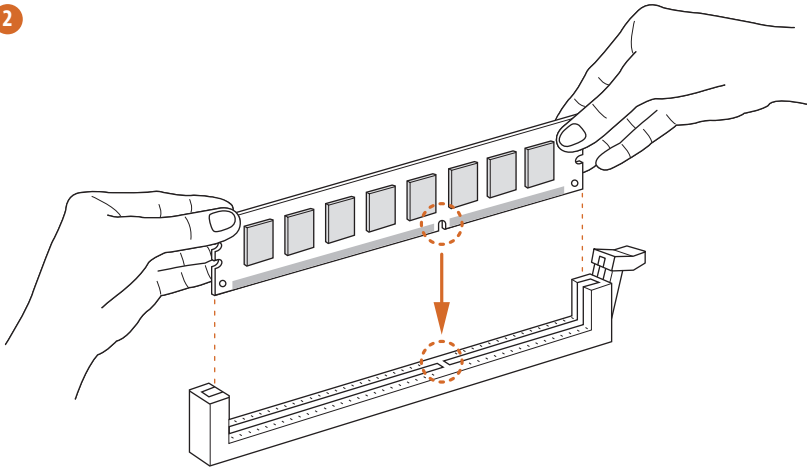

3

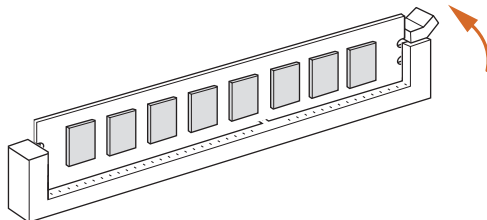

## 2.4 Expansion Slots (PCI Express Slots)

There are 3 PCI Express slots on the motherboard.



*Before installing an expansion card, please make sure that the power supply is switched off or the power cord is unplugged. Please read the documentation of the expansion card and make necessary hardware settings for the card before you start the installation.*

### PCIe slots:

PCIe1 (PCIe 3.0 x16 slot) is used for PCI Express x16 lane width graphics cards.

PCIe2 (PCIe 3.0 x1 slot) is used for PCI Express x1 lane width cards.

PCIe3 (PCIe 3.0 x16 slot) is used for PCI Express x2 lane width graphics cards.

### PCIe Slot Configurations

	PCIe1	PCIe2	PCIe3
<b>Ryzen Series CPUs (Matisse)</b>	x16	x1	x2
<b>Ryzen Series CPUs (Renoir)</b>	x16	x1	x2



*For a better thermal environment, please connect a chassis fan to the motherboard's chassis fan connector (CHA\_FAN1/WP, CHA\_FAN2/WP or CHA\_FAN3/WP) when using multiple graphics cards.*

## 2.5 Jumpers Setup

The illustration shows how jumpers are setup. When the jumper cap is placed on the pins, the jumper is “Short”. If no jumper cap is placed on the pins, the jumper is “Open”.

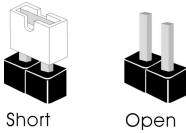

---

Clear CMOS Jumper  
(CLR CMOS1)  
(see p.1, No. 19)



Short: Clear CMOS  
Open: Default

---

CLR CMOS1 allows you to clear the data in CMOS. The data in CMOS includes system setup information such as system password, date, time, and system setup parameters. To clear and reset the system parameters to default setup, please turn off the computer and unplug the power cord, then use a jumper cap to short the pins on CLR CMOS1 for 3 seconds. Please remember to remove the jumper cap after clearing the CMOS. If you need to clear the CMOS when you just finish updating the BIOS, you must boot up the system first, and then shut it down before you do the clear-CMOS action.

## 2.6 Onboard Headers and Connectors



Onboard headers and connectors are NOT jumpers. Do NOT place jumper caps over these headers and connectors. Placing jumper caps over the headers and connectors will cause permanent damage to the motherboard.

System Panel Header  
(9-pin PANEL1)  
(see p.1, No. 12)

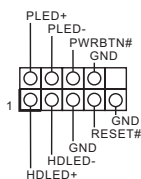

Connect the power button, reset button and system status indicator on the chassis to this header according to the pin assignments below. Note the positive and negative pins before connecting the cables.



**PWRBTN (Power Button):**

Connect to the power button on the chassis front panel. You may configure the way to turn off your system using the power button.

**RESET (Reset Button):**

Connect to the reset button on the chassis front panel. Press the reset button to restart the computer if the computer freezes and fails to perform a normal restart.

**PLED (System Power LED):**

Connect to the power status indicator on the chassis front panel. The LED is on when the system is operating. The LED keeps blinking when the system is in S1/S3 sleep state. The LED is off when the system is in S4 sleep state or powered off (S5).

**HDLED (Hard Drive Activity LED):**

Connect to the hard drive activity LED on the chassis front panel. The LED is on when the hard drive is reading or writing data.

The front panel design may differ by chassis. A front panel module mainly consists of power button, reset button, power LED, hard drive activity LED, speaker and etc. When connecting your chassis front panel module to this header, make sure the wire assignments and the pin assignments are matched correctly.

Power LED and Speaker Header  
(7-pin SPK\_PLED1)  
(see p.1, No. 13)

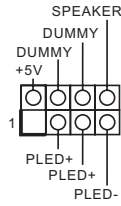

Please connect the chassis power LED and the chassis speaker to this header.

Serial ATA3 Connectors  
Vertical:  
(SATA3\_1:

see p.1, No. 10)

(SATA3\_2:

see p.1, No. 9)

Right Angle:

(SATA3\_3:

see p.1, No. 11)(Lower)

(SATA3\_4:

see p.1, No. 11)(Upper)

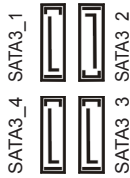

These four SATA3 connectors support SATA data cables for internal storage devices with up to 6.0 Gb/s data transfer rate. \* M2\_2 and SATA3\_3\_4 share lanes. If either one of them is in use, the other one will be disabled.

USB 2.0 Headers  
(9-pin USB\_3\_4)  
(see p.1, No. 15)  
(9-pin USB\_5\_6)  
(see p.1, No. 16)

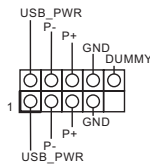

There are two headers on this motherboard. Each USB 2.0 header can support two ports.

USB 3.2 Gen1 Header  
(19-pin F\_USB3\_1\_2)  
(see p.1, No. 8)

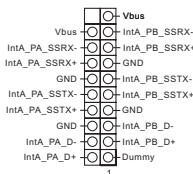

There is a header on this motherboard. This USB 3.2 Gen1 header can support two ports.

Front Panel Audio Header  
(9-pin HD\_AUDIO1)  
(see p.1, No. 22)

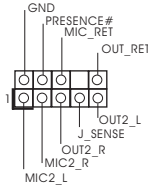

This header is for connecting audio devices to the front audio panel.



1. High Definition Audio supports Jack Sensing, but the panel wire on the chassis must support HDA to function correctly. Please follow the instructions in our manual and chassis manual to install your system.
2. If you use an AC'97 audio panel, please install it to the front panel audio header by the steps below:
  - A. Connect Mic\_IN (MIC) to MIC2\_L.
  - B. Connect Audio\_R (RIN) to OUT2\_R and Audio\_L (LIN) to OUT2\_L.
  - C. Connect Ground (GND) to Ground (GND).
  - D. MIC\_RET and OUT\_RET are for the HD audio panel only. You don't need to connect them for the AC'97 audio panel.
  - E. To activate the front mic, go to the "FrontMic" Tab in the Realtek Control panel and adjust "Recording Volume".

Chassis Water Pump Fan Connectors  
(4-pin CHA\_FAN1/WP)  
(see p.1, No. 23)

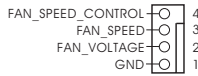

This motherboard provides three 4-Pin water cooling chassis fan connectors. If you plan to connect a 3-Pin chassis water cooler fan, please connect it to Pin 1-3.

(4-pin CHA\_FAN2/WP)  
(see p.1, No. 18)  
(4-pin CHA\_FAN3/WP)  
(see p.1, No. 14)

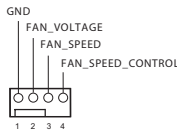

CPU Fan Connector  
(4-pin CPU\_FAN1)  
(see p.1, No. 2)

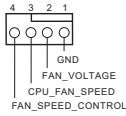

This motherboard provides a 4-Pin CPU fan (Quiet Fan) connector. If you plan to connect a 3-Pin CPU fan, please connect it to Pin 1-3.

ATX Power Connector  
(24-pin ATXPWR1)  
(see p.1, No. 7)

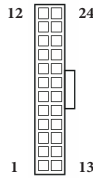

This motherboard provides a 24-pin ATX power connector. To use a 20-pin ATX power supply, please plug it along Pin 1 and Pin 13.

ATX 12V Power Connector  
(8-pin ATX12V1)  
(see p.1, No. 1)

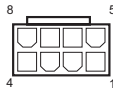

This motherboard provides an 8-pin ATX 12V power connector. To use a 4-pin ATX power supply, please plug it along Pin 1 and Pin 5.

**\*Warning: Please make sure that the power cable connected is for the CPU and not the graphics card. Do not plug the PCIe power cable to this connector.**

SPI TPM Header  
(13-pin SPI\_TPM\_J1)  
(see p.1, No. 17)

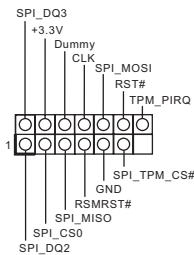

This connector supports SPI Trusted Platform Module (TPM) system, which can securely store keys, digital certificates, passwords, and data. A TPM system also helps enhance network security, protects digital identities, and ensures platform integrity.

RGB LED Headers  
(4-pin RGB\_LED1)  
(see p.1, No. 5)



These two RGB headers are used to connect RGB LED extension cable which allows users to choose from various LED lighting effects.

**Caution: Never install the RGB LED cable in the wrong orientation; otherwise, the cable may be damaged.**

\*Please refer to page 37 for further instructions on these two headers.

(4-pin RGB\_LED2)  
(see p.1, No. 21)



Addressable LED Headers  
(3-pin ADDR\_LED1)  
(see p.1, No. 6)

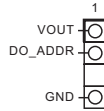

These two Addressable headers are used to connect Addressable LED extension cable which allows users to choose from various LED lighting effects.

**Caution: Never install the Addressable LED cable in the wrong orientation; otherwise, the cable may be damaged.**

\*Please refer to page 38 for further instructions on this header.

(3-pin ADDR\_LED2)  
(see p.1, No. 20)

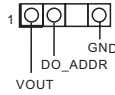



## 2.7 M.2\_SSD (NGFF) Module Installation Guide (M2\_1)

The M.2, also known as the Next Generation Form Factor (NGFF), is a small size and versatile card edge connector that aims to replace mPCIe and mSATA.

The Ultra M.2 Socket (M2\_1) supports M Key type 2280 M.2 PCI Express module up to Gen3x4 (32 Gb/s).

### Installing the M.2\_SSD (NGFF) Module

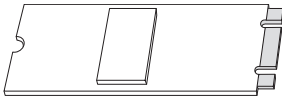

#### Step 1

Prepare a M.2\_SSD (NGFF) module and the screw.

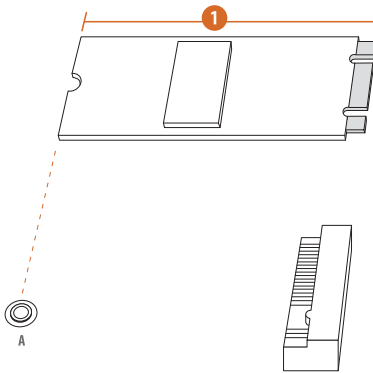

#### Step 2

Depending on the PCB type and length of your M.2\_SSD (NGFF) module, find the corresponding nut location to be used.

No.	1
Nut Location	A
PCB Length	8cm
Module Type	Type2280

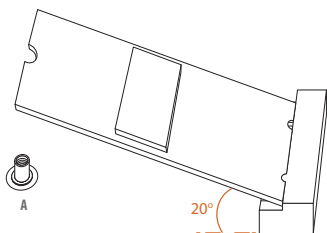
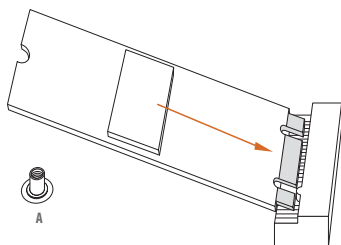

### **Step 3**

Align and gently insert the M.2 (NGFF) SSD module into the M.2 slot. Please be aware that the M.2 (NGFF) SSD module only fits in one orientation.

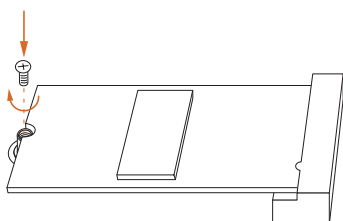

### **Step 4**

Tighten the screw with a screwdriver to secure the module into place. Please do not overtighten the screw as this might damage the module.

## M.2\_SSD (NGFF) Module Support List (M2\_1)

Vendor	Interface	P/N
ADATA	PCIe3 x4	ASX7000NP-128GT-C
ADATA	PCIe3 x4	ASX8000NP-256GM-C
ADATA	PCIe3 x4	ASX7000NP-256GT-C
ADATA	PCIe3 x4	ASX8000NP-512GM-C
ADATA	PCIe3 x4	ASX7000NP-512GT-C
Apacer	PCIe3 x4	AP240GZ280
Corsair	PCIe3 x4	CSSD-F240GBMP500
Intel	PCIe3 x4	SSDPEKKF256G7
Intel	PCIe3 x4	SSDPEKKF512G7
Kingston	PCIe3 x4	SKC1000/480G
Kingston	PCIe2 x4	SH2280S3/480G
OCZ	PCIe3 x4	RVD400 -M2280-512G (NVME)
PATRIOT	PCIe3 x4	PH240GPM280SSDR NVME
Plextor	PCIe3 x4	PX-128M8PeG
Plextor	PCIe3 x4	PX-1TM8PeG
Plextor	PCIe3 x4	PX-256M8PeG
Plextor	PCIe3 x4	PX-512M8PeG
Plextor	PCIe	PX-G256M6e
Plextor	PCIe	PX-G512M6e
Samsung	PCIe3 x4	SM961 MZVPPW128HEGM (NVM)
Samsung	PCIe3 x4	PM961 MZVLW128HEGR (NVME)
Samsung	PCIe3 x4	960 EVO (MZ-V6E250) (NVME)
Samsung	PCIe3 x4	960 EVO (MZ-V6E250BW) (NVME)
Samsung	PCIe3 x4	SM951 (NVME)
Samsung	PCIe3 x4	SM951 (MZHPV256HDGL)
Samsung	PCIe3 x4	SM951 (MZHPV512HDGL)
Samsung	PCIe3 x4	SM951 (NVME)
SanDisk	PCIe	SD6PP4M-128G
SanDisk	PCIe	SD6PP4M-256G
TEAM	PCIe3 x4	TM8FP2240G0C101
TEAM	PCIe3 x4	TM8FP2480GC110
WD	PCIe3 x4	WDS256G1X0C-00ENX0 (NVME)
WD	PCIe3 x4	WDS512G1X0C-00ENX0 (NVME)

For the latest updates of M.2\_SSD (NFGG) module support list, please visit our website for details: <http://www.asrock.com>

## 2.8 M.2\_SSD (NGFF) Module Installation Guide (M2\_2)

The M.2, also known as the Next Generation Form Factor (NGFF), is a small size and versatile card edge connector that aims to replace mPCIe and mSATA. The M.2 Socket (M2\_2) supports M Key type 2280 M.2 SATA3 6.0 Gb/s module and M.2 PCI Express module up to Gen3 x2 (16 Gb/s).

\* M2\_2 and SATA3\_3\_4 share lanes. If either one of them is in use, the other one will be disabled.

### Installing the M.2\_SSD (NGFF) Module

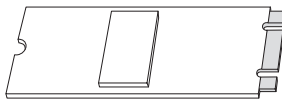

#### Step 1

Prepare a M.2\_SSD (NGFF) module and the screw.

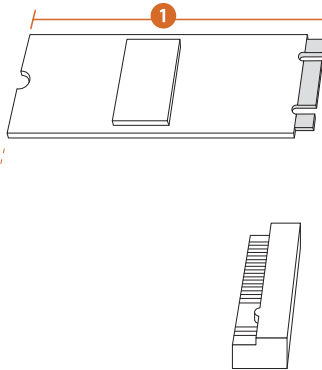

#### Step 2

Depending on the PCB type and length of your M.2\_SSD (NGFF) module, find the corresponding nut location to be used.

No.	1
Nut Location	A
PCB Length	8cm
Module Type	Type2280

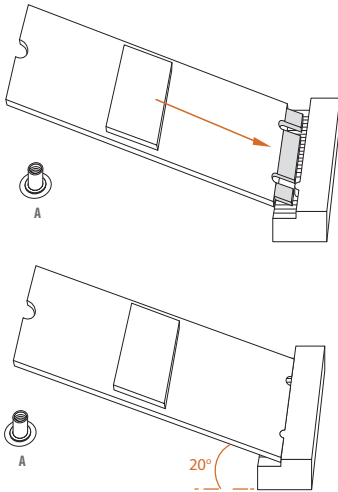
**Step 3**

Align and gently insert the M.2 (NGFF) SSD module into the M.2 slot. Please be aware that the M.2 (NGFF) SSD module only fits in one orientation.

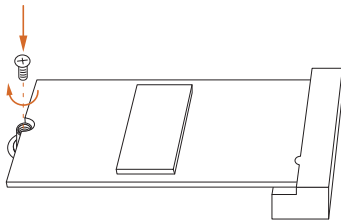
**Step 4**

Tighten the screw with a screwdriver to secure the module into place. Please do not overtighten the screw as this might damage the module.

## M.2\_SSD (NGFF) Module Support List (M2\_2)

Vendor	Interface	P/N
ADATA	SATA3	AXNS330E-32GM-B
ADATA	SATA3	AXNS381E-128GM-B
ADATA	SATA3	AXNS381E-256GM-B
ADATA	SATA3	ASU800NS38-256GT-C
ADATA	SATA3	ASU800NS38-512GT-C
Crucial	SATA3	CT120M500SSD4
Crucial	SATA3	CT240M500SSD4
Intel	SATA3	Intel SSDSCKGW080A401/80G
Kingston	SATA3	SM2280S3
Plextor	PCIe	PX-G256M6e
Plextor	PCIe	PX-G512M6e
SanDisk	PCIe	SD6PP4M-128G
SanDisk	PCIe	SD6PP4M-256G
Team	SATA3	TM4PS4128GMC105
Team	SATA3	TM4PS4256GMC105
Team	SATA3	TM8PS4128GMC105
Team	SATA3	TM8PS4256GMC105
Transcend	SATA3	TS256GMTS400
Transcend	SATA3	TS512GMTS600
Transcend	SATA3	TS512GMTS800
V-Color	SATA3	VLM100-120G-2280B-RD
V-Color	SATA3	VLM100-240G-2280RGB
V-Color	SATA3	VSM100-240G-2280
V-Color	SATA3	VLM100-240G-2280B-RD
WD	SATA3	WDS100T1B0B-00AS40
WD	SATA3	WDS240G1G0B-00RC30

For the latest updates of M.2\_SSD (NFGG) module support list, please visit our website for details: <http://www.asrock.com>

## 2.9 ASRock Polychrome SYNC

ASRock Polychrome SYNC is a lighting control utility specifically designed for unique individuals with sophisticated tastes to build their own stylish colorful lighting system. Simply by connecting the LED strip, you can customize various lighting schemes and patterns, including Static, Breathing, Strobe, Cycling, Music, Wave and more.

### Connecting the LED Strip

Connect your RGB LED strips to the **RGB LED Headers (RGB\_LED1, RGB\_LED2)** on the motherboard.

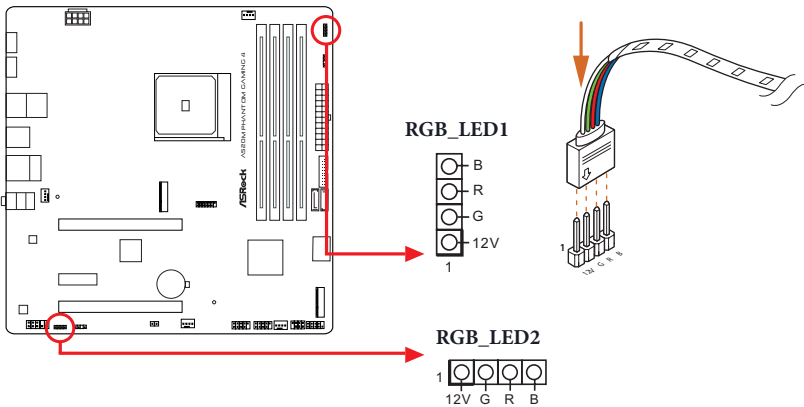

1. Never install the RGB LED cable in the wrong orientation; otherwise, the cable may be damaged.
2. Before installing or removing your RGB LED cable, please power off your system and unplug the power cord from the power supply. Failure to do so may cause damages to motherboard components.



1. Please note that the RGB LED strips do not come with the package.
2. The RGB LED header supports standard 5050 RGB LED strip (12V/G/R/B), with a maximum power rating of 3A (12V) and length within 2 meters.

## Connecting the Addressable RGB LED Strip

Connect your Addressable RGB LED strips to the **Addressable LED Headers (ADDR\_LED1, ADDR\_LED2)** on the motherboard.

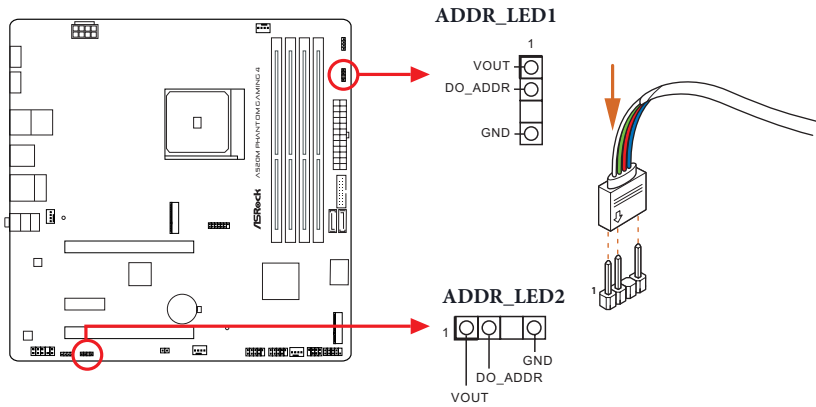

1. Never install the RGB LED cable in the wrong orientation; otherwise, the cable may be damaged.
2. Before installing or removing your RGB LED cable, please power off your system and unplug the power cord from the power supply. Failure to do so may cause damages to motherboard components.



1. Please note that the RGB LED strips do not come with the package.
2. The RGB LED header supports WS2812B addressable RGB LED strip (5V/Data/GND), with a maximum power rating of 3A (5V) and length within 2 meters.



## ASRock Polychrome SYNC Utility

Now you can adjust the RGB LED color through the ASRock Polychrome SYNC Utility. Download this utility from the ASRock Live Update & APP Shop and start coloring your PC style your way!

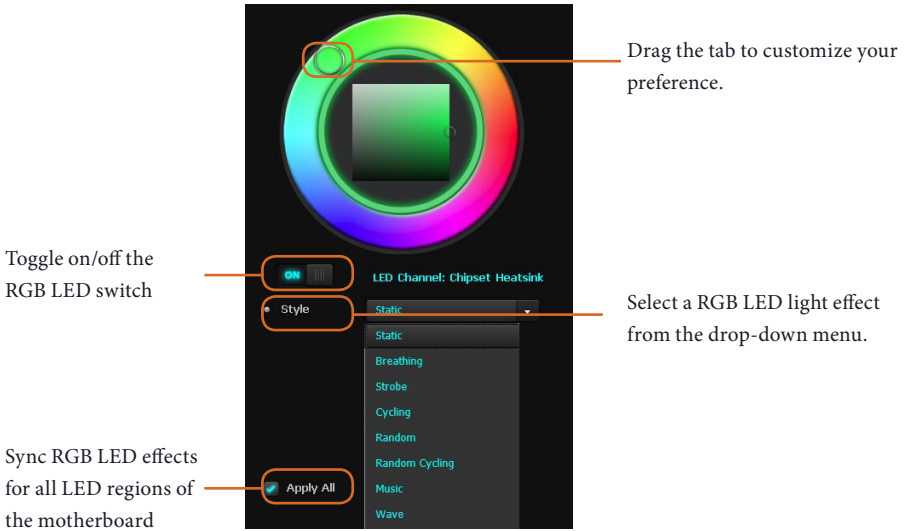

# 1 Einleitung

Vielen Dank, dass Sie sich für das ASRock A520M Phantom Gaming 4 entschieden haben – ein zuverlässiges Motherboard, das konsequent unter der strengen Qualitätskontrolle von ASRock hergestellt wurde. Es liefert ausgezeichnete Leistung mit robustem Design, das ASRock Streben nach Qualität und Beständigkeit erfüllt.



*Da die technischen Daten des Motherboards sowie die BIOS-Software aktualisiert werden können, kann der Inhalt dieser Dokumentation ohne Ankündigung geändert werden. Falls diese Dokumentation irgendwelchen Änderungen unterliegt, wird die aktualisierte Version ohne weitere Hinweise auf der ASRock-Webseite zur Verfügung gestellt. Sollten Sie technische Hilfe in Bezug auf dieses Motherboard benötigen, erhalten Sie auf unserer Webseite spezifischen Informationen über das von Ihnen verwendete Modell. Auch finden Sie eine aktuelle Liste unterstützter VGA-Karten und Prozessoren auf der ASRock-Webseite. ASRock-Webseite <http://www.asrock.com>.*

## 1.1 Lieferumfang

- ASRock A520M Phantom Gaming 4-Motherboard (Micro-ATX-Formfaktor)
- ASRock A520M Phantom Gaming 4-Schnellinstallationsanleitung
- ASRock A520M Phantom Gaming 4-Support-CD
- 1 x E/A-Blendenabschirmung
- 2 x Serial-ATA- (SATA) Datenkabel (optional)
- 2 x Schrauben für M.2-Sockel (optional)

## 1.2 Technische Daten

### Plattform

- Micro-ATX-Formfaktor
- Feststoffkondensator-Design
- Platine mit zwei Unzen Kupfergehalt

### Prozessor

- Unterstützt AMD AM4 Ryzen™ der 3. Generation / AMD Ryzen™-Prozessoren und höher (Prozessoren der 3000er- und 4000er-Serie)\*
- \* Nicht kompatibel mit AMD Ryzen™ 5 3400G und Ryzen™ 3 3200G
- Digi Power design
- 8-Leistungsphasendesign

### Chipsatz

- AMD A520

### Speicher

- Dualkanal-DDR4-Speichertechnologie
- 4 x DDR4-DIMM-Steckplätze
- Prozessoren der AMD-Ryzen-Serie (Matisse) unterstützen DDR4 4533+(OC)/4466(OC)/4400(OC)/4333(OC)/4266(OC)/4200(OC)/4133(OC)/4000(OC)/3866(OC)/3800(OC)/3733(OC)/3600(OC)/3466(OC)/3200/2933/2667/2400/2133 ECC und non-ECC, ungepufferter Speicher\*
- APUs (Renoir) der AMD-Ryzen-Serie unterstützen DDR4 4733+(OC)/4666(OC)/4600(OC)/4533(OC)/4466(OC)/4400(OC)/4333(OC)/4266(OC)/4200(OC)/4133(OC)/4000(OC)/3866(OC)/3800(OC)/3733(OC)/3600(OC)/3466(OC)/3200/2933/2667/2400/2133 ECC und non-ECC, ungepufferter Speicher\*

\* Weitere Informationen finden Sie in der Speicherkompatibilitätsliste auf der ASRock-Webseite. (<http://www.asrock.com/>)

\* Bitte beachten Sie Seite 22 für die maximal unterstützte Frequenz von DDR4-UDIMM.

- Systemspeicher, max. Kapazität: 128GB
- Unterstützt Extreme-Memory-Profile- (XMP) Speichermodule
- 15-µ-Goldkontakt in DIMM-Steckplätze

### **Erweiterungssteckplatz**

- 2 x PCI-Express 3.0 x16-Steckplätze (PCI-E1: x16-Modus; PCI-E3: x2-Modus)\*
- \* Unterstützt NVMe-SSD als Bootplatte
- 1 x PCI-Express 3.0-x1-Steckplatz

### **Grafikkarte**

- Integrierte Grafikkarte der AMD-Radeon™-Vega-Serie in APU der Ryzen-Serie\*
- \* Tatsächliche Unterstützung kann je nach Prozessor variieren
- DirectX 12, Pixel Shader 5.0
- Freigabespeicher von standardmäßig 2GB. Max. Freigabespeicher unterstützt bis zu 16GB.
- \* Der max. Freigabespeicher von 16GB erfordert die Installation von 32GB Systemspeicher.
- Dualer Grafikkartenausgang: Unterstützt HDMI- und DisplayPort 1.4-Ports durch unabhängige Monitor-Controller
- Unterstützt HDMI 2.1 mit maximaler Auflösung von 4K x 2K (4096 x 2160) bei 60 Hz
- Unterstützt DisplayPort 1.4 mit maximaler Auflösung von bis zu 5K (5120 x 2880) bei 120 Hz
- Unterstützt Auto-Lippensynchronizität, hohe Farbtiefe (12 bpc), xvYCC und HBR (Audio mit hoher Bitrate) mit HDMI 2.1-Port (konformer HDMI-Monitor erforderlich)
- Unterstützt HDR (High Dynamic Range) mit HDMI 2.1
- Unterstützt HDCP 2.3 mit HDMI 2.1- und DisplayPort 1.4-Ports
- Unterstützt 4K-Ultra-HD- (UHD) Wiedergabe mit HDMI 2.1- und DisplayPort-1.4-Ports
- Unterstützt Microsoft PlayReady®

### **Audio**

- 7.1-Kanal-HD-Audio (Realtek ALC887/897-Audiocodec)
- Unterstützt Überspannungsschutz

### **LAN**

- PCI-E-x1-Gigabit-LAN 10/100/1000 Mb/s
- Realtek RTL8111H
- Unterstützt Wake-On-LAN
- Unterstützt Schutz gegen Blitzschlag/elektrostatische Entladung
- Unterstützt energieeffizientes Ethernet 802.3az
- Unterstützt PXE

**Rückblende,  
E/A**

- 1 x PS/2-Maus-/Tastaturanschluss
- 1 x HDMI-Port
- 1 x DisplayPort 1.4
- 4 x USB-3.2-Gen1-Ports (unterstützt Schutz gegen elektrostatische Entladung)
- 2 x USB-2.0-Ports (unterstützt Schutz gegen elektrostatische Entladung)
- 1 x RJ-45-LAN-Port mit LED (Aktivität/Verbindung-LED und Geschwindigkeit-LED)
- HD-Audioanschlüsse: Line-in / Vorderer Lautsprecher / Mikrofon

**Speicher**

- 4 x SATA-III-6,0-Gb/s-Anschlüsse, unterstützt RAID (RAID 0, RAID 1 und RAID 10), NCQ, AHCI und Hot-Plugging\*
- \* M2\_2, und SATA3\_3\_4 nutzen Lanes gemeinsam. Wenn einer von ihnen benutzt wird, wird der andere deaktiviert.
- 1 x Ultra-M.2-Sockel (M2\_1), unterstützt M-Key-Typ-2280-M.2-PCI-Express-Modul bis Gen3 x 4 (32 Gb/s)\*\*
- 1 x M.2-Sockel (M2\_2), unterstützt M-Key-Typ-2280-M.2-SATA-III-6,0-Gb/s-Modul und M.2-PCI-Express-Modul bis Gen3 x 2 (16 Gb/s)\*\*
- \*\* Unterstützt NVMe-SSD als Bootplatte
- \*\* Unterstützt ASRock U.2-Kit

**Anschluss**

- 1 x SPI-TPM-Stiftleiste
- 1 x Betrieb-LED- und Lautsprecher-Stiftleiste
- 2 x RGB-LED-Stiftleisten
- \* Unterstützt insgesamt bis zu 12 V/3 A, 36-W-LED-Streifen
- 2 x Adressierbare-LED-Stiftleiste
- \* Unterstützen insgesamt bis zu 5 V/3 A, 15-W-LED-Streifen
- 1 x CPU-Lüfteranschluss (4-polig)
- \* Der CPU-Lüfteranschluss unterstützt einen CPU-Lüfter mit einer maximalen Lüfterleistung von 1 A (12 W).
- 3 x Anschlüsse für Gehäuse-/Wasserpumpenlüfter (4-polig) (intelligente Lüftergeschwindigkeitssteuerung)
- \* Der Gehäuse-/Wasserpumpenlüfter unterstützt einen Wasserkühlerlüfter mit einer maximalen Lüfterleistung von 2 A (24 W).
- \* CHA\_FAN1/WP, CHA\_FAN2/WP, und CHA\_FAN3/WP können automatisch erkennen, ob ein 3- oder 4-poliger Lüfter verwendet wird.

- 1 x 24-poliger ATX-Netzanschluss
- 1 x 8-poliger 12-V-Netzanschluss
- 1 x Audioanschluss an Frontblende
- 2 x USB 2.0-Stiflleisten (unterstützt 4 USB 2.0-Ports)  
(unterstützt Schutz gegen elektrostatische Entladung)
- 1 x USB 3.2 Gen1-Stiflleiste (unterstützt 2 USB 3.2 Gen1-Ports)  
(unterstützt Schutz gegen elektrostatische Entladung)

#### **BIOS- Funktion**

- AMI-UEFI-Legal-BIOS mit Unterstützung grafischer Benutzerschnittstellen
- Unterstützt „Plug-and-Play“
- ACPI 5.1-konforme Aufweckereignisse
- Unterstützt Jumper-frei
- SMBIOS 2.3-Unterstützung
- CPU, CPU VDDCR\_SOC, DRAM, +1,8VSB  
Mehrfachspannungsanpassung

#### **Hardware- überwachung**

- Temperaturerkennung: CPU-, Gehäuse-/Wasserpumpen-Lüfter
- Lüftertachometer: CPU-, Gehäuse-/Wasserpumpen-Lüfter
- Lautloser Lüfter (automatische Anpassung der Gehäuselüftergeschwindigkeit durch CPU-Temperatur):  
CPU-, Gehäuse-/Wasserpumpen-Lüfter
- Mehrfachgeschwindigkeitssteuerung: CPU-, Gehäuse-/  
Wasserpumpen-Lüfter
- Spannungsüberwachung: +12V, +5V, +3,3V, CPU Vcore,  
CPU VDDCR\_SOC, DRAM, VPPM, +1,8V

#### **Betriebs- system**

- Microsoft® Windows® 10, 64 Bit

#### **Zertifizierun- gen**

- FCC, CE
- ErP/EuP ready (ErP/EuP ready-Netzteil erforderlich)

\* Detaillierte Produktinformationen finden Sie auf unserer Webseite: <http://www.asrock.com>



Bitte beachten Sie, dass mit einer Übertaktung, zu der die Anpassung von BIOS-Einstellungen, die Anwendung der Untied Overclocking Technology oder die Nutzung von Übertaktungswerkzeugen von Drittanbietern zählen, bestimmte Risiken verbunden sind. Eine Übertaktung kann sich auf die Stabilität Ihres Systems auswirken und sogar Komponenten und Geräte Ihres Systems beschädigen. Sie sollte auf eigene Gefahr und eigene Kosten durchgeführt werden. Wir übernehmen keine Verantwortung für mögliche Schäden, die durch eine Übertaktung verursacht wurden.

# 1 Introduction

Nous vous remercions d'avoir acheté cette carte mère ASRock A520M Phantom Gaming 4, une carte mère fiable fabriquée conformément au contrôle de qualité rigoureux et constant appliqué par ASRock. Fidèle à son engagement de qualité et de durabilité, ASRock vous garantit une carte mère de conception robuste aux performances élevées.



*Les spécifications de la carte mère et du logiciel BIOS pouvant être mises à jour, le contenu de ce document est soumis à modification sans préavis. En cas de modifications du présent document, la version mise à jour sera disponible sur le site Internet ASRock sans notification préalable. Si vous avez besoin d'une assistance technique pour votre carte mère, veuillez visiter notre site Internet pour plus de détails sur le modèle que vous utilisez. La liste la plus récente des cartes VGA et des processeurs pris en charge est également disponible sur le site Internet de ASRock. Site Internet ASRock <http://www.asrock.com>.*

## 1.1 Contenu de l'emballage

- Carte mère ASRock A520M Phantom Gaming 4 (facteur de forme Micro ATX)
- Guide d'installation rapide ASRock A520M Phantom Gaming 4
- CD d'assistance ASRock A520M Phantom Gaming 4
- 1 x panneau de protection E/S
- 2 x câbles de données Serial ATA (SATA) (Optionnel)
- 2 x vis pour sockets M.2 (Optionnel)



## 1.2 Spécifications

- Plateforme**
- Facteur de forme Micro ATX
  - Conception à condensateurs solides
  - PCB cuivre 2 onces

- Processeur**
- Prend en charge la 3<sup>ème</sup> AMD AM4 Ryzen™ / AMD Ryzen™ prochaine génération (processeurs séries 3000 et 4000)\*
  - \* Non compatible avec AMD Ryzen™ 5 3400G et Ryzen™ 3 3200G
  - Digi Power design
  - Alimentation à 8 phases

- Chipset**
- AMD A520

- Mémoire**
- Technologie mémoire double canal DDR4
  - 4 x fentes DIMM DDR4
  - Les Processeurs AMD série Ryzen (Matisse) prennent en charge les mémoires sans tampon ECC et non ECC DDR4 4533+(OC)/4466(OC)/4400(OC)/4333(OC)/4266(OC)/4200(OC)/4133(OC)/4000(OC)/3866(OC)/3800(OC)/3733(OC)/3600(OC)/3466(OC)/3200/2933/2667/2400/2133\*
  - Les APU AMD série Ryzen (Renoir) prennent en charge les mémoires sans tampon ECC et non ECC DDR4 4733+(OC)/4666(OC)/4600(OC)/4533(OC)/4466(OC)/4400(OC)/4333(OC)/4266(OC)/4200(OC)/4133(OC)/4000(OC)/3866(OC)/3800(OC)/3733(OC)/3600(OC)/3466(OC)/3200/2933/2667/2400/2133\*
- \* Veuillez consulter la liste de prise en charge des mémoires sur le site Web d'ASRock pour de plus amples informations. (<http://www.asrock.com/>)
- \* Veuillez consulter la page 22 pour connaître la prise en charge de la fréquence maximale de l'UDIMM DDR4.
- Capacité max. de la mémoire système : 128 Go
  - Prend en charge les modules mémoire Extreme Memory Profile (XMP)
  - Contacts dorés 15µ sur fentes DIMM

## Fente d'expansion

2 x fentes PCI Express 3.0 x 16 (PCIe1: mode x16 ; PCIe3 : mode x2)\*

\* Prend en charge les SSD NVMe comme disques de démarrage

- 1 x fente PCI Express 3.0 x 1

## Graphiques

- Carte graphique AMD Radeon™ série Vega intégrée dans APU série Ryzen\*

\* La prise en charge réelle peut varier selon le processeur

- DirectX 12, Pixel Shader 5.0
- Mémoire partagée par défaut 2 Go. Mémoire partagée maximum prise en charge 16 Go.

\* La mémoire partagée maximum de 16 Go nécessite 32 Go de mémoire système installée.

- Double sortie graphique : Prend en charge les ports HDMI et DisplayPort 1.4 via contrôleurs d'affichage indépendants
- Prend en charge la technologie HDMI 2.1 avec résolution maximale de 4K x 2K (4096x2160) @ 60 Hz
- Prend en charge DisplayPort 1.4 avec résolution maximale jusqu'à 5K (5120x2880) à 120 Hz
- Prend en charge les technologies Auto Lip Sync, Deep Color (12bpc), xvYCC et HBR (High Bit Rate Audio) avec port HDMI 2.1 (un écran compatible HDMI est requis)
- Prend en charge HDR (Plage dynamique étendue) avec HDMI 2.1
- Prend en charge HDCP 2.3 via ports HDMI 2.1 et DisplayPort 1.4
- Prend en charge la lecture 4K Ultra HD (UHD) avec les ports HDMI 2.1 et DisplayPort 1.4
- Prend en charge Microsoft PlayReady®

## Audio

- Audio 7.1 CH HD (Codec audio Realtek ALC887/897)
- Prend en charge la protection contre les surtensions

## Réseau

- PCIe x1 Gigabit LAN 10/100/1000 Mo/s
- Realtek RTL8111H
- Prend en charge la fonction Wake-On-LAN
- Prend en charge la protection contre la foudre/les décharges électrostatiques

- Prend en charge la fonction d'économie d'énergie Ethernet 802.3az
- Prend en charge PXE

### Connectique du panneau arrière

- 1 x port souris/clavier PS/2
- 1 x port HDMI
- 1 x DisplayPort 1.4
- 4 x ports USB 3.2 Gen1 (Protection contre les décharges électrostatiques)
- 2 x ports USB 2.0 (Protection contre les décharges électrostatiques)
- 1 x port RJ-45 LAN avec LED (LED ACT/LIEN et LED VITESSE)
- Connecteurs jack audio HD : Entrée ligne / haut-parleur avant / microphone

### Stockage

- 4 x connecteurs SATA3 6,0 Go/s, prise en charge de RAID (RAID 0, RAID 1 et RAID 10), NCQ, AHCI et branchement à chaud\*

\* Lignes partagées M2\_2, et SATA3\_3\_4. Si l'un des deux est utilisé, l'autre sera désactivé.

- 1 x socket Ultra M.2 (M2\_1), prend en charge les modules M.2 PCI Express type 2280 touche M jusqu'à Gen3 x4 (32 Go/s)\*\*
- 1 x socket M.2 (M2\_2), prend en charge les modules M.2 SATA3 6,0 Go/s type 2280 et M.2 PCI Express touche M jusqu'à Gen3 x2 (16 Go/s)\*\*

\*\* Prend en charge les SSD NVMe comme disques de démarrage

\*\* Prend en charge le kit ASRock U.2

### Connecteur

- 1 x embase SPI TPM
- 1 x prise DEL d'alimentation et haut-parleur
- 2 x embase LED RVB

\* Prend en charge les rubans LED jusqu'à 12 V/3 A, 36 W au total

- 2 x embases LED adressables

\* Prend en charge les rubans LED jusqu'à 5 V/3 A, 15 W au total

- 1 x connecteur pour ventilateur de CPU (4 broches)

\* Le connecteur pour ventilateur de CPU prend en charge un ventilateur de CPU d'une puissance maximale de 1 A (12 W).

- 3 x connecteurs pour ventilateur de châssis /pompe à eau (4 broches) (contrôle de vitesse de ventilateur intelligent)
- \* Le ventilateur de châssis /pompe à eau prend en charge un ventilateur de refroidisseur d'eau d'une puissance maximale de 2 A (24 W).
- \* CHA\_FAN1/WP, CHA\_FAN2/WP, et CHA\_FAN3/WP peuvent détecter automatiquement si un ventilateur 3 broches ou 4 broches est utilisé.
- 1 x connecteur d'alimentation ATX 24 broches
  - 1 x connecteur d'alimentation 12V 8 broches
  - 1 x connecteur audio panneau frontal
  - 2 x embases USB 2.0 (4 ports USB 2.0 pris en charge) (Protection contre les décharges électrostatiques)
  - 1 x embase USB 3.2 Gen1 (2 ports USB 3.2 Gen1 pris en charge) (Protection contre les décharges électrostatiques)

#### **Caractéristiques du BIOS**

- BIOS UEFI AMI avec prise en charge d'interface graphique
- Prend en charge la fonction « Plug and Play »
- Compatible ACPI 5.1 Wake Up Events
- Prend en charge la configuration Jumpfree
- Compatible SMBIOS 2.3
- Réglage de la tension CPU, CPU VDDCR\_SOC, DRAM, +1,8VSB

#### **Surveillance du matériel**

- Détection de température : Ventilateurs de CPU / châssis / pompe à eau
- Tachymètre de ventilateur : Ventilateurs de CPU / châssis / pompe à eau
- Ventilateur silencieux (réglage automatique de la vitesse du ventilateur du châssis d'après la température du CPU) : Ventilateurs de CPU / châssis / pompe à eau
- Contrôle simultané des vitesses du ventilateur : Ventilateurs de CPU / châssis / pompe à eau
- Surveillance de la tension d'alimentation : +12V, +5V, +3,3V, CPU Vcore, CPU VDDCR\_SOC, DRAM, VPPM, +1,8V

#### **Système d'exploitation**

- Microsoft® Windows® 10 64 bits

#### **Certifications**

- FCC, CE
- ErP/EuP Ready (alimentation ErP/EuP ready requise)

\* pour des informations détaillées de nos produits, veuillez visiter notre site : <http://www.asrock.com>



*Il est important de signaler que l'overclocking présente certains risques, incluant des modifications du BIOS, l'application d'une technologie d'overclocking déliée et l'utilisation d'outils d'overclocking développés par des tiers. La stabilité de votre système peut être affectée par ces pratiques, voire provoquer des dommages aux composants et aux périphériques du système. L'overclocking se fait à vos risques et périls. Nous ne pourrions en aucun cas être tenus pour responsables des dommages éventuels provoqués par l'overclocking.*

# 1 Introduzione

Congratulazioni per l'acquisto della scheda madre ASRock A520M Phantom Gaming 4, una scheda madre affidabile prodotta secondo i severissimi controlli di qualità ASRock. La scheda madre offre eccellenti prestazioni con un design robusto che si adatta all'impegno di ASRock di offrire sempre qualità e durata.



*Dato che le specifiche della scheda madre e del software BIOS possono essere aggiornate, il contenuto di questa documentazione sarà soggetto a variazioni senza preavviso. Nel caso di eventuali modifiche della presente documentazione, la versione aggiornata sarà disponibile sul sito Web di ASRock senza ulteriore preavviso. Per il supporto tecnico correlato a questa scheda madre, visitare il nostro sito Web per informazioni specifiche relative al modello attualmente in uso. È possibile trovare l'elenco di schede VGA più recenti e di supporto di CPU anche sul sito Web di ASRock. Sito Web di ASRock <http://www.asrock.com>.*

## 1.1 Contenuto della confezione

- Scheda madre ASRock A520M Phantom Gaming 4 (Form Factor Micro ATX)
- Guida rapida di installazione ASRock A520M Phantom Gaming 4
- CD di supporto ASRock A520M Phantom Gaming 4
- 1 x mascherina metallica posteriore I/O
- 2 x cavi dati Serial ATA (SATA) (opzionali)
- 2 x viti per Socket M.2 (opzionali)

## 1.2 Specifiche

- Piattaforma**
- Fattore di forma Micro ATX
  - Design condensatore solido
  - PCB 2oz rame

- CPU**
- Supporta AMD AM4 Ryzen™/AMD Ryzen™ di terza generazione e successive generazioni (processori serie 3000 e 4000) \*
  - \* Non compatibile con AMD Ryzen™ 5 3400G e Ryzen™ 3 3200G.
  - Digi Power design
  - Potenza a 8 fasi

- Chipset**
- AMD A520

- Memoria**
- Tecnologia memoria DDR4 Dual Channel
  - 4 x alloggi DIMM DDR4
  - Le CPU serie AMD Ryzen (Matisse) supportano DDR4 4533+(OC)/4466(OC)/4400(OC)/4333(OC)/4266(OC)/4200(OC)/4133(OC)/4000(OC)/3866(OC)/3800(OC)/3733(OC)/3600(OC)/3466(OC)/3200/2933/2667/2400/2133 ECC e non ECC, senza buffer\*
  - Le APU AMD Ryzen (Renoir) supportano DDR4 4733+(OC)/4666(OC)/4600(OC)/4533(OC)/4466(OC)/4400 (OC)/4333(OC)/4266(OC)/4200(OC)/4133(OC)/4000 (OC)/3866(OC)/3800(OC)/3733(OC)/3600(OC)/3466 (OC)/3200/2933/2667/2400/2133 ECC e non ECC, senza buffer\*
  - \* Per maggiori informazioni fare riferimento all'elenco dei supporti di memoria sul sito di ASRock. (<http://www.asrock.com/>)
  - \* Fare riferimento a pagina 22 per il supporto della frequenza massima DDR4 UDIMM.
  - Capacità max. della memoria di sistema: 128GB
  - Supporta moduli di memoria Extreme Memory Profile (XMP)
  - Contatti d'oro 15µ negli alloggi DIMM

- Alloggio d'espansione**
- 2 x PCI Express 3.0 x 16 slot (PCIE1: modalità x16; PCIE3: modalità x2)\*
  - \* Supporto di SSD NVMe come disco d'avvio
  - 1 x alloggiamento PCI Express 3.0 x1

**Grafica**

- Grafica AMD Radeon™ serie Vega integrata nelle APU serie Ryzen\*
- \* Il supporto effettivo può variare in base alla CPU
- DirectX 12, Pixel Shader 5.0
- Memoria condivisa predefinita 2 GB. Memoria condivisa massima supporta fino a 16 GB.
- \* La memoria condivisa massima di 16 GB richiede che sia installata una memoria di sistema da 32 GB.
- Doppia uscita grafica: supporto di porte HDMI e DisplayPort 1.4 tramite controller display indipendenti
- Supporta HDMI 2.1 con risoluzione massima fino a 4K x 2K (4096 x 2160) a 60 Hz
- Supporta DisplayPort 1.4 con risoluzione massima fino a 5K (5120 x 2880) a 120 Hz
- Supporto delle funzioni Auto Lip Sync, Deep Color (12bpc), xvYCC e HBR (High Bit Rate Audio) con porta HDMI 2.1 (è necessario un monitor compatibile HDMI)
- Supporta HDR (High Dynamic Range) con HDMI 2.1
- Supporto HDCP 2.3 con le porte HDMI 2.1 e DisplayPort 1.4
- Supporto riproduzione 4K Ultra HD (UHD) sulle porte HDMI 2.1 e DisplayPort 1.4
- Supporto Microsoft PlayReady®

**Audio**

- Audio HD 7.1 CH (codec audio Realtek ALC887/897)
- Supporta protezione da sovratensione

**LAN**

- 1 x PCIE LAN Gigabit 10/100/1000 Mb/s
- Realtek RTL8111H
- Supporto WOL (Wake-On-LAN)
- Supporta protezione da fulmini/scariche elettrostatiche
- Supporto Energy Efficient Ethernet 802.3az
- Supporto PXE

**I/O pannello posteriore**

- 1 x porta mouse/tastiera PS/2
- 1 x porta HDMI
- 1 x DisplayPort 1.4
- 4 x porte USB 3.2 Gen1 (supporto protezione da scariche elettrostatiche)
- 2 x porte USB 2.0 (supporto protezione da scariche elettrostatiche)



- 1 x porta LAN RJ-45 con LED (ACT/LINK LED e SPEED LED)
- Connettori audio HD: Ingresso linea / altoparlante frontale / microfono

### Archiviazione

- 4 x connettori SATA3 6,0 Gb/s, supporto RAID (RAID 0, RAID 1, e RAID 10), NCQ, AHCI e Hot Plug\*
- \* M2\_2, e SATA3\_3\_4 condividono le corsie. Se uno di essi è utilizzato, l'altro sarà disabilitato.
- 1 x socket Ultra M.2 (M2\_1), supporta il modulo M.2 PCI Express di tipo M Key 2280 fino a Gen3 x4 (32 Gb/s)\*\*
- 1 x Socket M.2 (M2\_2), supporta il modulo M.2 SATA3 6,0 Gb/s di tipo M Key 2280 ed il modulo M.2 PCI Express fino a Gen3 x2 (16 Gb/s)\*\*
- \*\* Supporto di SSD NVMe come disco d'avvio
- \*\* Supporta kit ASRock U.2

### Connettore

- 1 x connettore SPI TPM
- 1 x connettore LED alimentazione e altoparlante
- 2 x collettore LED RGB
- \* Supporto totale di fino a 12 V/3 A, 36 W strip LED
- 2 x Header LED indirizzabili
- \* Supporto totale di strisce LED fino a 5 V/3 A, 15 W
- 1 x connettore ventola CPU (4-pin)
- \* Il connettore ventola CPU supporta ventole CPU con potenza massima di 1 A (12 W).
- 3 x connettori ventola telaio/ventola pompa dell'acqua (4-pin) (Controllo intelligente della velocità della ventola)
- \* La ventola Chassis/ventola pompa dell'acqua supporta ventole di sistemi di raffreddamento ad acqua di potenza massima di 2 A (24 W).
- \* CHA\_FAN1/WP, CHA\_FAN2/WP e CHA\_FAN3/WP sono in grado di rilevare se è in uso una ventola a 3 pin o 4 a pin.
- 1 x connettore alimentazione ATX 24-pin
- 1 x connettore alimentazione 12 V 8-pin
- 1 x connettore audio pannello frontale
- 2 x connettori USB 2.0 (supporto di 4 porte USB 2.0) (supporta protezione da scariche elettrostatiche)
- 1 x header USB 3.2 Gen1 (supporto di 2 porte USB 3.2 Gen1) (supporto protezione da scariche elettrostatiche)

**Funzionalità  
BIOS**

- AMI UEFI Legal BIOS con interfaccia di supporto
- Supporta “Plug and Play”
- Eventi di riattivazione conformi a ACPI 5.1
- Supporta jumperfree
- Supporto di SMBIOS 2.3
- Regolazione variabile tensione CPU, CPU VDDCR\_SOC, DRAM, +1,8VSB

**Hardware  
Monitor**

- Sensore di temperatura: Ventole CPU, chassis, pompa dell'acqua
- Tachimetro ventola: Ventole CPU, chassis, pompa dell'acqua
- Ventola silenziosa (regolazione automatica velocità in base alla temperatura della CPU): Ventole CPU, chassis, pompa dell'acqua
- Controllo velocità ventola: Ventole CPU, chassis, pompa dell'acqua
- Monitoraggio tensione: +12V, +5V, +3,3V, CPU Vcore, CPU VDDCR\_SOC, DRAM, VPPM, +1,8V

**SO**

- Microsoft® Windows® 10 64 bit

**Certificazioni**

- FCC, CE
- ErP/EuP Ready (è necessaria alimentazione ErP/EuP ready)

\* Per informazioni dettagliate sul prodotto, visitare il nostro sito Web: <http://www.asrock.com>



*Prestare attenzione al potenziale rischio previsto nella pratica di overclocking, inclusa la regolazione delle impostazioni nel BIOS, l'applicazione di tecnologia di Untied Overclocking o l'utilizzo di strumenti di overclocking di terze parti. L'overclocking può influenzare la stabilità del sistema o perfino provocare danni ai componenti e ai dispositivi del sistema. Occorre eseguirlo a proprio rischio e spese. Non ci riterremo responsabili per possibili danni provocati da overclocking.*

# 1 Introducción

Gracias por comprar la placa base ASRock A520M Phantom Gaming 4, una placa base fiable fabricada según el rigurosísimo control de calidad de ASRock. Ofrece un rendimiento excelente con un diseño resistente de acuerdo con el compromiso de calidad y resistencia de ASRock.



*Ya que las especificaciones de la placa base y el software de la BIOS podrán ser actualizados, el contenido que aparece en esta documentación estará sujeto a modificaciones sin previo aviso. Si esta documentación sufre alguna modificación, la versión actualizada estará disponible en el sitio web de ASRock sin previo aviso. Si necesita asistencia técnica relacionada con esta placa base, visite nuestro sitio web para obtener información específica sobre el modelo que esté utilizando. Podrá encontrar las últimas tarjetas VGA, así como la lista de compatibilidad de la CPU, en el sitio web de ASRock. Sitio web de ASRock <http://www.asrock.com>.*

## 1.1 Contenido del paquete

- Placa base ASRock A520M Phantom Gaming 4 (Factor de forma Micro ATX)
- Guía de instalación rápida de ASRock A520M Phantom Gaming 4
- CD de soporte de ASRock A520M Phantom Gaming 4
- 1 x escudo panel E/S
- 2 x Cables de datos Serie ATA (SATA) (Opcional)
- 2 x tornillos para socket M.2 (Opcional)

## 1.2 Especificaciones

- Plataforma**
- Factor de forma Micro ATX
  - Diseño de condensador sólido
  - Circuito impreso (PCB) de 2 oz de cobre

- CPU**
- Admite AMD AM4 Ryzen™ / Ryzen™ de 3ª generación y posteriores Procesadores (Procesadores de las Series 3000 y 4000)\*
- \* No es compatible con AMD Ryzen™ 5 3400G o Ryzen™ 3 3200G.
- Digi Power design
  - Diseño de 8 fases de alimentación

- Conjunto de chips**
- AMD A520

- Memoria**
- Tecnología de memoria DDR4 de doble canal
  - 4 x ranuras DIMM DDR4
  - Las CPU de la serie AMD Ryzen (Matisse) admiten memoria sin búfer DDR4 4533+(OC)/4466(OC)/4400(OC)/4333(OC)/4266(OC)/4200(OC)/4133(OC)/4000(OC)/3866(OC)/3800(OC)/3733(OC)/3600(OC)/3466(OC)/3200/2933/2667/2400/2133 ECC y no ECC\*
  - Las APU de la serie AMD Ryzen (Renoir) admiten memoria sin búfer DDR4 4733+(OC)/4666(OC)/4600(OC)/4533(OC)/4466(OC)/4400(OC)/4333(OC)/4266(OC)/4200(OC)/4133(OC)/4000(OC)/3866(OC)/3800(OC)/3733(OC)/3600(OC)/3466(OC)/3200/2933/2667/2400/2133 ECC y no ECC\*

\* Para obtener más información, consulte la lista de memorias compatibles en el sitio web de ASRock. (<http://www.asrock.com/>)

\* Consulte la página 22 para conocer las frecuencias máximas compatibles de DDR4 UDIMM.

- Capacidad máxima de memoria del sistema: 128GB
- Admite módulos de memoria Extreme Memory Profile (XMP)
- Contacto 15µ Gold en ranuras DIMM

- Ranura de expansión**
- 2 ranura PCI Express 3.0 x16 (PCIE1: modo x16; PCIE3: modo x2)\*
- \* Admite unidad de estado sólido de NVMe como disco de arranque
- 1 x ranura PCI Express 3.0 x1

**Gráficos**

- Tarjeta gráfica de la serie AMD Radeon™ Vega integrada en APU de la serie Ryzen\*
- \* El soporte real puede variar según la CPU
- DirectX 12, Pixel Shader 5.0
- Memoria compartida predeterminada de 2 GB. Memoria máxima compartida admite hasta 16 GB.
- \* La memoria compartida máxima de 16GB requiere que haya una memoria del sistema de 32GB instalada.
- Salida gráfica dual: compatible con puertos HDMI y DisplayPort 1.4 mediante controladores de pantalla independientes
- Compatible con HDMI 2.1 con una resolución máxima de 4K x 2K (4096x2160) a 60Hz
- Admite DisplayPort 1.4 con una resolución máxima de hasta 5K (5120x2880) a 120Hz
- Admite Sincronización automática entre audio y vídeo, color profundo (12 bpc), xvYCC y HBR (audio de alta tasa de bits) con puerto HDMI 2.1 (se necesita un monitor compatible con HDMI)
- Admite HDR (alto rango dinámico) con HDMI 2.1
- Compatible con HDCP 2.3 con puertos HDMI 2.1 y DisplayPort 1.4
- Admite reproducción 4K Ultra HD (UHD) con los puertos HDMI 2.1 y DisplayPort 1.4
- Compatible con Microsoft PlayReady®

**Audio**

- 7.1 Audio CH HD (Código de audio Realtek ALC887/897)
- Admite protección contra sobretensiones

**LAN**

- PCIE x1 Gigabit LAN 10/100/1000 Mb/s
- Realtek RTL8111H
- Admite la función Reactivación de LAN
- Admite protección contra rayos y descargas electrostáticas (ESD)
- Admite Ethernet 802.3az de eficiencia energética
- Admite PXE

**E/S en panel posterior**

- 1 x puerto de ratón/teclado PS/2
- 1 x puerto HDMI
- 1 x DisplayPort 1.4
- 4 x Puertos USB 3.2 Gen1 (admite protección contra descargas electrostáticas)
- 2 x Puertos USB 2.0 (admite protección contra descargas electrostáticas)
- 1 x Puerto LAN RJ-45 con LED (LED DE ACTIVIDAD/ ENLACE y LED DE VELOCIDAD)
- Conector de audio HD: Entrada de línea / Altavoz frontal / Micrófono

**Almacenamiento**

- 4 x conectores SATA3 de 6,0 Gb/s, compatible con RAID (RAID 0, RAID 1 y RAID 10), NCQ, AHCI y conexión en caliente\*  
\* M2\_2, y SATA3\_3\_4 comparten carriles. Si cualquiera de ellos está en uso, el otro se deshabilitará.
  - 1 x Zócalo Ultra M.2 (M2\_1), compatible con el módulo PCI Express M.2 tipo 2280 con clave M hasta Gen3 x4 (32 Gb/s)\*\*
  - 1 x Zócalo M.2 (M2\_2) que admite el módulo SATA3 6,0 Gb/s M.2 de tipo2280 con clave M y el módulo PCI Express M.2 hasta Gen3 x2 (16 Gb/s)\*\*
- \*\* Admite unidad de estado sólido de NVMe como disco de arranque  
\*\* Admite el kit U.2 de ASRock

**Conector**

- 1 x Conector SPI TPM
  - 1 x LED de alimentación y base de conexiones para el altavoz
  - 2 x Cabezales de indicador LED RGB
- \* Admite una tira de LED de hasta 12 V/3 A (36 W) en total
- 2 x cabezales de LED direccionables
- \* Admite una tira de LED de hasta 5 V/3 A (15 W) en total
- 1 x Conector para ventilador de la CPU (4 contactos)
- \* El conector para ventilador de la CPU admite ventilador de la CPU con una potencia de ventilador de 1 A (12 W) máxima.

- 3 x Conectores (4 contactos) para el ventilador de la bomba de agua/chasis (control de velocidad de ventilador inteligente)
- \* El ventilador de la bomba de agua/Chasis admite ventilador del disipador por agua con una potencia de ventilador máxima de 2 A (24 W).
- \* CHA\_FAN1/WP, CHA\_FAN2/WP y CHA\_FAN3/WP se pueden detectar automáticamente si se usa el ventilador de 3 o 4 contactos.
  - 1 x conector de alimentación ATX de 24 contactos
  - 1 x conector de alimentación de 12V de 8 contactos
  - 1 x Conector de audio en el panel frontal
  - 2 x Bases de conexiones USB 2.0 (Admite 4 puertos USB 2.0) (Admite protección contra descargas electrostáticas)
  - 1 x base de conexiones USB 3.2 Gen1 (admite 2 puertos USB 3.2 Gen1) (Admite protección contra descargas electrostáticas)

#### **Función de la BIOS**

- BIOS legal UEFI AMI compatible con interfaz gráfica de usuario
- Compatible con "Plug and Play"
- Eventos de reactivación conformes con ACPI 5.1
- Compatible con Jumper FREE
- Admite SMBIOS 2.3
- Multi-ajuste de voltaje de CPU, CPU VDDCR\_SOC, DRAM, +1,8VSB

#### **Monitor de hardware**

- Detección de temperatura: Ventiladores de la bomba de agua/chasis/CPU
- Tacómetro del ventilador: Ventiladores de la bomba de agua/chasis/CPU
- Ventilador silencioso (ajuste automático de la velocidad del ventilador del chasis por temperatura de la CPU): Ventiladores de la bomba de agua/chasis/CPU
- Control de varias velocidades del ventilador: Ventiladores de la bomba de agua/chasis/CPU
- Supervisión del voltaje: +12V, +5V, +3,3V, CPU Vcore, CPU VDDCR\_SOC, DRAM, VPPM, +1,8V

#### **SO**

- Microsoft® Windows® 10 64 bits

#### **Certificaciones**

- FCC y CE
- Preparado para ErP/EuP (se necesita una fuente de alimentación preparada para ErP/EuP)

\* Para obtener información detallada del producto, visite nuestro sitio Web: <http://www.asrock.com>



*Tenga en cuenta que hay un cierto riesgo implícito en las operaciones de overclocking, incluido el ajuste de la BIOS, aplicando la tecnología de overclocking liberada o utilizando las herramientas de overclocking de otros fabricantes. El overclocking puede afectar a la estabilidad del sistema e, incluso, dañar los componentes y dispositivos del sistema. Esta operación se debe realizar bajo su propia responsabilidad y usted debe asumir los costos. No asumimos ninguna responsabilidad por los posibles daños causados por el overclocking.*



# 1 Введение

Благодарим вас за приобретение надежной материнской платы ASRock A520M Phantom Gaming 4, выпускаемой под постоянным строгим контролем компании ASRock. Эта материнская плата обеспечивает великолепную производительность и отличается надежной конструкцией в соответствии с требованиями компании ASRock в отношении качества и долговечности.



*По причине обновления характеристик системной платы и программного обеспечения BIOS содержимое настоящей документации может быть изменено без предварительного уведомления. При изменении содержимого настоящего документа его обновленная версия будет доступна на веб-сайте ASRock без предварительного уведомления. При необходимости технической поддержки, связанной с материнской платой, посетите веб-сайт и найдите на нем информацию о модели используемой вами материнской платы. На веб-сайте ASRock также можно найти самый последний перечень поддерживаемых VGA-карт и ЦП. Веб-сайт ASRock <http://www.asrock.com>.*

## 1.1 Комплект поставки

- Материнская плата ASRock A520M Phantom Gaming 4 (форм-фактор Micro ATX)
- Краткое руководство по установке ASRock A520M Phantom Gaming 4
- Диск с ПО ASRock A520M Phantom Gaming 4
- 1 экран панели с портами ввода-вывода
- 2 кабеля передачи данных Serial ATA (SATA) (приобретаются отдельно)
- 2 винта для слота M.2 (приобретаются отдельно)

## 1.2 Технические характеристики

### Платформа

- Форм-фактор Micro ATX
- Схема на основе твердотельных конденсаторов
- Медная печатная плата (2 унции)

### ЦП

- Поддержка процессоров AMD AM4 Ryzen™ / AMD Ryzen™ 3-го и будущих поколений (процессоры серии 3000 и 4000)\*
- \* Несовместимо с процессорами AMD Ryzen™ 5 3400G и Ryzen™ 3 3200G
- Digi Power design
- Система питания 8

### Чипсет

- AMD A520

### Память

- Двухканальная память DDR4
- 4 гнезда DDR4 DIMM
- ЦП серии AMD Ryzen (Matisse) поддерживают модули памяти DDR4 4533+(OC)/4466(OC)/4400(OC)/4333(OC)/4266(OC)/4200(OC)/4133(OC)/4000(OC)/3866(OC)/3800(OC)/3733(OC)/3600(OC)/3466(OC)/3200/2933/2667/2400/2133 с ECC и без ECC, небуферизованной памяти\*
- Гибридные процессоры AMD серии Ryzen (Renoir) поддерживают модули памяти DDR4 4733+(OC)/4666(OC)/4600(OC)/4533(OC)/4466(OC)/4400 (OC)/4333(OC)/4266(OC)/4200(OC)/4133(OC)/4000 (OC)/3866(OC)/3800(OC)/3733(OC)/3600(OC)/3466 (OC)/3200/2933/2667/2400/2133 с ECC и без ECC, небуферизованной памяти\*

\* Дополнительная информация представлена в Списке совместимой памяти (Memory Support List) на веб-сайте ASRock. (<http://www.asrock.com/>)

\* Максимальные поддерживаемые частоты DDR4 UDIMM см на стр. 22.

- Максимальный объем ОЗУ: 128 ГБ
- Поддержка модулей памяти XMP (Extreme Memory Profile)
- Позолоченные (15 мкм) контакты слотов DIMM

**Слоты  
расширения**

- 2 x PCI Express 3.0 x16 гнезд (PCIЕ1: режим x16; PCIЕ3: режим x2)\*
- \* Поддерживаются в качестве загрузочных SSD-диски типа NVMe
- 1 слот PCI Express 3.0 x1

**Графическая  
подсистема**

- Встроенный видеоадаптер AMD Radeon™ серии Vega в процессорах APU серии Ryzen\*
- \*Фактическая поддержка зависит от процессора
- DirectX 12, пиксельные шейдеры 5.0
- Общий объем памяти по умолчанию 2 ГБ. Поддерживается максимальный общий объем памяти до 16 ГБ.
- \* Для максимального общего объема памяти 16 ГБ требуется установить системную память емкостью 32 ГБ.
- Два графических выхода: поддержка портов HDMI и DisplayPort 1.4 независимыми контроллерами дисплея
- Поддержка HDMI 2.1 с максимальным разрешением до 4K × 2K (4096x2160) при 60 Гц
- Поддержка DisplayPort 1.4 с максимальным разрешением до 5K (5120x2880) при частоте 120 Гц
- Поддерживаются Auto Lip Sync, Deep Color (12 бит/цвет), xvYCC и HBR (High Bit Rate Audio) через порт HDMI 2.1 (требуется соответствующий HDMI-монитор)
- Поддерживается расширенный динамический диапазон (HDR) в режиме HDMI 2.1
- Поддерживается функция HDCP 2.3 через порты HDMI 2.1 и DisplayPort 1.4
- Поддержка вывода видео с разрешением 4K Ultra HD (UHD) на порты HDMI 2.1 и DisplayPort 1.4
- Поддержка Microsoft PlayReady®

**Звук**

- 7.1-канальный звук высокой четкости (аудиокодек Realtek ALC887/897)
- Защита от перепадов напряжения в электрической сети

**LAN**

- PCIE x1 Gigabit LAN 10/100/1000 Мбит/с
- Realtek RTL8111H
- Поддерживается пробуждение по ЛВС
- Молниезащита и защита от электростатических разрядов
- Поддерживается Energy Efficient Ethernet 802.3az
- Поддерживается PXE

**Тыловые порты ввода-вывода**

- 1 порт PS/2 для мыши/клавиатуры
- 1 порт HDMI
- 1 порт DisplayPort 1.4
- 4 портов USB 3.2 Gen1 (с защитой от электростатических разрядов)
- 2 порта USB 2.0 (с защитой от электростатических разрядов)
- 1 порт ЛВС RJ-45 с индикаторами («Активность/Соединение» и «Скорость»)
- Разъемы HD Audio: линейный вход / фронтальные AC / микрофон

**Запоминающие устройства**

- 4 порта SATA3 со скоростью передачи данных 6,0 Гбит/с, поддержка RAID (RAID 0, RAID 1 и RAID 10), NCQ, AHCI и «горячего подключения».\*

\* Общие каналы M2\_2, и SATA3\_3\_4. Если используется один из этих двух слотов, второй будет отключен.

- 1 слот Ultra M.2 (M2\_1), поддерживается модуль M.2 PCI Express типа 2280 с ключом M до версии Gen3 x4 (32 Гбит/с)\*\*
- 1 слот M.2 (M2\_2), поддерживает модуль M.2 SATA3 типа 2280 с пропускной способностью 6,0 Гбит/с и модуль M.2 PCI Express до версии Gen3 x2 (16 Гбит/с)\*\*

\*\* Поддерживаются в качестве загрузочных SSD-диски типа NVMe

\*\* Поддерживается комплект ASRock U.2

**Разъемы**

- 1 колодка SPI TPM
- 1 колодка светодиодного индикатора питания и корпусного динамика
- 2 колодки для подключения светодиодной RGB-подсветки
- \* Поддерживается светодиодная лента (максимум 12 В/3 А, суммарной мощностью до 36 Вт)
  - 2 колодки адресуемой светодиодной подсветки
- \* Поддерживается светодиодная лента (максимум 5 В/3 А, суммарной мощностью до 15 Вт)
  - 1 разъем для вентилятора охлаждения ЦП (4-контактный)
- \* Разъем процессорного вентилятора поддерживает вентилятор с потребляемым током не более 1 А (12 Вт).
  - 3 разъемы для корпусного вентилятора или водяной помпы (4-контактный) (смарт-регулятор скорости вентилятора)
- \* Разъем для корпуса корпусного вентилятора или водяной помпы поддерживает вентилятор с потребляемым током не более 2 А (24 Вт).
- \* Для разъемов CHA\_FAN1/WP, CHA\_FAN2/WP и CHA\_FAN3/WP автоматически определяется тип подключенного вентилятора: 3- или 4-контактный.
  - 1 разъем питания ATX, 24-контактный
  - 1 разъем питания 12 В, 8-контактный
  - 1 аудиоразъем для передней панели
  - 2 колодки USB 2.0 (4 порта USB 2.0) (с защитой от электростатических разрядов)
  - 1 колодка USB 3.2 Gen1 (2 порта USB 3.2 Gen1) (с защитой от электростатических разрядов)

**Параметры BIOS**

- AMI UEFI Legal BIOS с поддержкой графического интерфейса
- Поддержка технологии «Plug and Play»
- Совместимость с управлением энергопотреблением по ACPI 5.1
- Поддержка функции JumperFree
- Поддерживается SMBIOS 2.3
- Регулировка напряжений CPU, CPU VDDCR\_SOC, DRAM, +1,8VSB

**Контроль оборудования**

- Контроль температуры: вентилятор ЦП; корпусной вентилятор или помпа водяного охлаждения корпуса
- Тахометр: вентилятор ЦП; корпусной вентилятор или помпа водяного охлаждения корпуса
- Бесшумная работа (с автоматической регулировкой скорости вращения в зависимости от температуры ЦП): вентилятор ЦП; корпусной вентилятор или помпа водяного охлаждения корпуса
- Регулировка скорости вращения: вентилятор ЦП; корпусной вентилятор или помпа водяного охлаждения корпуса
- Контроль напряжений: +12 В, +5 В, +3,3 В, напряжение ядра ЦП, VDDCR\_SOC ЦП, DRAM, VPPM, +1,8 В

**Операционные системы**

- Microsoft® Windows® 10 (64-разрядная)

**Сертификация**

- FCC, CE
- Совместимость с ErP/EuP (необходим блок питания, соответствующий стандарту ErP/EuP)

\* С дополнительной информацией об изделии можно ознакомиться на веб-сайте: <http://www.asrock.com>



*Следует учитывать, что разгон процессора, включая изменение настроек BIOS, применение технологии Untied Overclocking и использование инструментов разгона независимых производителей, сопряжен с определенным риском. Разгон процессора может снизить стабильность системы или даже привести к повреждению ее компонентов и устройств. Разгон процессора осуществляется пользователем на собственный риск и за собственный счет. Мы не несем ответственность за возможный ущерб, вызванный разгоном процессора.*

# 1 Introdução

Obrigado por adquirir a placa mãe ASRock A520M Phantom Gaming 4, uma confiável placa mãe ASRock produzida sob rigoroso controle de qualidade consistente. Esta placa principal oferece um excelente desempenho com um design robusto em conformidade com o compromisso da ASRock em fabricar produtos de qualidade e resistentes.



*Como as especificações da placa-mãe e do software do BIOS podem ser atualizadas, o conteúdo desta documentação estará sujeito a alterações sem aviso prévio. Caso ocorram modificações a esta documentação, a versão atualizada estará disponível no site da ASRock sem aviso prévio. Se precisar de assistência técnica relacionada a esta placa principal, visite o nosso site para obter informações específicas sobre o modelo que estiver utilizando. Você também poderá encontrar a lista de placas VGA e CPU mais recentes suportadas no site da ASRock. Site da ASRock <http://www.asrock.com>.*

## 1.1 Conteúdo da embalagem

- Placa Mãe ASRock A520M Phantom Gaming 4 (Micro ATX Form Factor)
- Guia de Instalação Rápida da ASRock A520M Phantom Gaming 4
- CD de Suporte do ASRock A520M Phantom Gaming 4
- 1 x Pannel de E/S
- 2 x Cabos de dados Serial ATA (SATA) (Opcional)
- 2 x Parafusos para Soquete M.2 (Opcional)

## 1.2 Especificações

- Plataforma**
- Micro ATX Form Factor
  - Design de condensador sólido
  - PCB 2oz de Cobre

- CPU**
- Suporta 3ª Ger AMD AM4 Ryzen™ / Ryzen™ futuras gerações de Processadores (Processadores Série 3000 e 4000)\*
  - \* Não compatível com AMD Ryzen™ 5 3400G e Ryzen™ 3 3200G.
  - Digi Power design
  - Design com 8 fases de alimentação

- Chipset**
- AMD A520

- Memória**
- Tecnologia de memória DDR4 de dois canais
  - 4 x Slots DIMM DDR4
  - CPUs série AMD Ryzen (Matisse) suporta DDR4 4533+(OC)/4466(OC)/4400(OC)/4333(OC)/4266(OC)/4200(OC)/4133(OC)/4000(OC)/3866(OC)/3800(OC)/3733(OC)/3600(OC)/3466(OC)/3200/2933/2667/2400/2133 ECC & não-ECC, memória sem buffer\*
  - AMD Ryzen série APUs (Renoir) suporta DDR4 4733+(OC)/4666(OC)/4600(OC)/4533(OC)/4466(OC)/4400(OC)/4333(OC)/4266(OC)/4200(OC)/4133(OC)/4000(OC)/3866(OC)/3800(OC)/3733(OC)/3600(OC)/3466(OC)/3200/2933/2667/2400/2133 ECC & não-ECC, memória sem buffer\*

\* Por favor, consulte a Lista de Suporte de Memória no site da ASRock para obter mais informação. (<http://www.asrock.com/>)

\* Por favor consulte a página 22 para suporte de frequência máxima DDR4 UDIMM.

- Capacidade máxima da memória do sistema: 128GB
- Suporta módulos de memória Extreme Memory Profile (XMP)
- Contato em Ouro 15µ nos slots DIMM

- Slot de expansão**
- 2 x Slot PCI Express 3.0 x16 (PCIe1: modo x16; PCIe3: modo x2)\*

\* Suporta NVMe SSD nos discos de inicialização

- 1 x slots PCI Express 3.0 x1



**Gráficos**

- AMD Radeon™ Integrado Série Vega Gráficas na Série Ryzen APU\*
- \* Suporte atual pode variar por CPU
- DirectX 12, Pixel Shader 5.0
- Memória compartilhada padrão 2GB. Memória compartilhada máx suporta até 16GB.
- \* A memória compartilhada máx de 16GB requer 32GB de memória de sistema instalado.
- Saída gráfica dupla: Suporta portas HDMI e DisplayPort 1.4 por controladores de vídeo independentes
- Suporta HDMI 2.1 com resolução máx. até 4K x 2K (4096x2160) @ 60Hz
- Suporta DisplayPort 1.4 com resolução máx. até 5K (5120x2880) @ 120Hz
- Suporta Auto sincronização labial, Deep Color (12bpc), xvYCC e HBR (High Bit Rate Audio) com porta HDMI 2.1 (É necessário um monitor compatível com HDMI)
- Suporta HDR (High Dynamic Range – Ampla Faixa Dinâmica) com HDMI 2.1
- Suporta HDCP 2.3 com Portas HDMI 2.1 e DisplayPort 1.4
- Suporta reprodução HD Ultra (UHD) 4K com portas HDMI 2.1 e DisplayPort 1.4
- Suporta Microsoft PlayReady\*

**Áudio**

- Áudio 7.1 CH HD com proteção de conteúdo (Codec de áudio Realtek ALC887/897)
- Suporta Proteção de Sobretensão

**LAN**

- LAN Gigabit 10/100/1000 Mb/s PCIE x1
- Realtek RTL8111H
- Suporta Wake-On-LAN
- Oferece Suporte à Proteção de Relâmpago/ESD
- Suporta Energy Efficient Ethernet 802.3az
- Suporta PXE

**E/S do painel posterior**

- 1 x Porta PS/2 para mouse/teclado
- 1 x Porta HDMI
- 1 x DisplayPort 1.4
- 4 x Portas USB 3.2 Gen1 (Suporta Proteção ESD)
- 2 x Portas USB 2.0 (Suporta Proteção ESD)
- 1 x Porta LAN RJ-45 com LED (LED ACT/LINK e LED DE VELOCIDADE)
- Fichas de áudio HD: Entrada de Linha / Autofalante Frontal / Microfone

**Armazenamento**

- 4 x Conectores SATA3 6,0 Gb/s, suporta RAID (RAID 0, RAID 1, e RAID 10), NCQ, AHC e Conexão a Quente\*

\* M2\_2, e SATA3\_3\_4 compartilham vias. Se qualquer um deles estiver em uso, o outro será desativado.

- 1 x soquete M.2 Ultra (M2\_1), suporta chave M tipo 2280 módulo M.2 PCI Express até Gen3 x4 (32 Gb/s) \*\*
- 1 x soquete M.2 (M2\_2), suporta chave M tipo 2280 módulo M.2 SATA3 6,0 Gb/s e módulo M.2 PCI Express até Gen3 x2 (16 Gb/s)\*\*

\*\* Suporta NVMe SSD como discos de inicialização

\*\* Suporta Kit ASRock U.2

**Conector**

- 1 x Plataforma SPI TPM
- 1 x LED de alimentação e Cabeçote de Autofalante
- 2 x Cabeçotes de LED RGB

\* Suporta no total até 12V/3A, Tira de LED de 36W

- 2 x Cabeçotes LED Endereçáveis

\* Suporte no total de até 5V/3A, Faixa LED de 15W

- 1 x Conector da ventoinha da CPU (4 pinos)

\* O Conector do Ventilador de CPU suporta o ventilador de CPU de alimentação máxima 1A do ventilador (12W).

- 3 x Conectores de Ventilador de Chassi/Ventilador da Bomba de Água (4 pinos) (Controle de Velocidade de Ventoinha Inteligente)

\* O Ventilador de Chassi/Ventilador da Bomba de Água suporta o ventilador de refrigerador a água de 2A máximo (24W) potência do ventilador.

\* CHA\_FAN1/WP, CHA\_FAN2/WP e CHA\_FAN3/WP podem detectar automaticamente se ventoinha de 3 pinos ou 4 pinos está em uso.

- 1 x Conector alimentação ATX 24-pinos
- 1 x Conector de energia 8-pinos 12V
- 1 x Conector de áudio do painel frontal
- 2 x Plataformas USB 2.0 (Suporta 4 portas USB 2.0) (Suporta Proteção ESD)
- 1 x Plataforma USB 3.2 Gen1 (Suporta 2 portas USB 3.2 Gen1) (Suporta Proteção ESD)

### **Funções da BIOS**

- AMI UEFI Legal BIOS com suporte GUI
- Suporta “Plug and Play”
- ACPI 5.1 compatível com eventos de despertar
- Suporta jumperfree
- Suporte SMBIOS 2.3
- Multi-ajuste de tensão de CPU, CPU VDDCR\_SOC, DRAM, +1,8VSB

### **Monitor de hardware**

- Sensor de Temperatura: Ventilador da CPU, Chassis/Bomba de Água
- Tacômetro da ventoinha: Ventilador da CPU, Chassis/Bomba de Água
- Ventoinha Silenciosa (Auto ajusta velocidade da ventoinha do chassi pela temperatura da CPU): Ventilador da CPU, Chassis/Bomba de Água
- Controle multi-velocidade da ventoinha: Ventilador da CPU, Chassis/Bomba de Água
- Monitoramento da tensão: +12V, +5V, +3,3V, CPU Vcore, CPU VDDCR\_SOC, DRAM, VPPM, +1,8V

### **SO**

- Microsoft® Windows® 10 64-bit

### **Certificações**

- FCC, CE
- Preparada para ErP/EuP (é necessária uma fonte de alimentação preparada para ErP/EuP)

\* Para obter informações detalhadas sobre o produto, por favor, visite o nosso site: <http://www.asrock.com>



*Por favor, observe que existe um certo risco envolvendo overclocking, incluindo o ajuste das definições na BIOS, a aplicação de tecnologia Untied Overclocking ou a utilização de ferramentas de overclocking de terceiros. O overclocking poderá afetar a estabilidade do sistema ou mesmo causar danos nos componentes e dispositivos do seu sistema. Ele deve ser realizado por sua conta e risco. Não nos responsabilizamos por possíveis danos causados pelo overclocking.*

# 1 Wprowadzenie

Dziękujemy za zakupienie płyty głównej ASRock A520M Phantom Gaming 4, niezawodnej płyty głównej produkowanej z konsekwentnie wykonywaną przez firmę ASRock, rygorystyczną kontrolą jakości. Płyta ta zapewnia doskonałą jakość działania i solidną konstrukcję, spełniającą zobowiązanie firmy ASRock do dostarczania produktów o wysokiej jakości i wytrzymałości.



*Ponieważ specyfikacje płyty głównej i oprogramowanie BIOS mogą zostać zaktualizowane, zawartość tej dokumentacji może zostać zmieniona bez powiadomienia. W przypadku jakichkolwiek modyfikacji tej dokumentacji, zaktualizowana wersja będzie dostępna na stronie internetowej ASRock, bez dalszego powiadomienia. Jeśli wymagana jest pomoc techniczna w odniesieniu do tej płyty głównej, należy odwiedzić stronę internetową w celu uzyskania specyficznych informacji o używanym modelu. Na stronie internetowej ASRock, można także pobrać listę najnowszych kart VGA i obsługiwanych CPU. Strona internetowa ASRock <http://www.asrock.com>.*

## 1.1 Zawartość opakowania

- Płyta główna ASRock A520M Phantom Gaming 4 (Współczynnik kształtu Micro ATX)
- Skrócona instrukcja instalacji ASRock A520M Phantom Gaming 4
- Pomocnicza płyta CD ASRock A520M Phantom Gaming 4
- 1 x osłona panelu Wejścia/Wyjścia
- 2 x kable danych Serial ATA (SATA) (Opcjonalne)
- 2 x śruby do gniazda M.2 (Opcjonalne)

## 1.2 Specyfikacje

### Platforma

- Współczynnik kształtu Micro ATX
- Konstrukcja kondensatorami stałymi
- PCB z 2 uncjami miedzi

### CPU

- Obsługa 3-ciej generacji procesorów AMD AM4 Ryzen™ / Ryzen™ z przyszłym procesorem (Procesory serii 3000 i 4000)\*
- \* Brak zgodności z AMD Ryzen™ 5 3400G i Ryzen™ 3 3200G.
- Digi Power design
- Sekcja zasilania 8 Power Phase Design

### Chipset

- AMD A520

### Pamięć

- Technologia pamięci Dual Channel DDR4
- 4 x gniazda DDR4 DIMM
- Seria CPU AMD Ryzen (Matisse) z obsługą niebuforowanej pamięci DDR4 4533+(OC)/4466(OC)/4400(OC)/4333(OC)/4266(OC)/4200(OC)/4133(OC)/4000(OC)/3866(OC)/3800(OC)/3733(OC)/3600(OC)/3466(OC)/3200/2933/2667/2400/2133 ECC i nie-ECC\*
- Seria APU AMD Ryzen (Renoir) z obsługą niebuforowanej pamięci DDR4 4733+ (OC)/4666(OC)/4600(OC)/4533(OC)/4466(OC)/4400 (OC)/4333(OC)/4266(OC)/4200(OC)/4133(OC)/4000 (OC)/3866(OC)/3800(OC)/3733(OC)/3600(OC)/3466 (OC)/3200/2933/2667/2400/2133 ECC i nie-ECC\*

\* Sprawdź listę obsługiwanej pamięci na stronie internetowej ASRock w celu uzyskania dalszych informacji.  
(<http://www.asrock.com/>)

\* Sprawdź stronę 22 w celu uzyskania informacji o maksymalnej obsługiwanej częstotliwości DDR4 UDIMM.

- Maks. wielkość pamięci systemowej: 128GB
- Obsługa modułów pamięci Extreme Memory Profile (XMP)
- 15μm połączone styki w gniazdach DIMM

### Gniazdo rozszerzenia

- 2 x gniazda PCI Express 3.0 x 16 (tryb PCIE1: tryb x16; PCIE3: tryb x2)\*

\* Obsługa SSD NVMe, jako dysków rozruchowych

- 1 x gniazdo PCI Express 3.0 x1

**Grafika**

- Zintegrowana karta graficzna AMD Radeon™ serii Vega w APU serii Ryzen\*
- \* Rzeczywista obsługa zależy od CPU
- DirectX 12, Pixel Shader 5.0
- Pamięć współdzielona, domyślnie 2GB. Maksymalnie pamięć współdzielona obsługuje do 16GB.
- \* Maksymalna pamięć współdzielona 16GB wymaga zainstalowania 32GB pamięci systemowej.
- Podwójne wyjście graficzne: Obsługa HDMI i DisplayPort 1.4 przez niezależne sterowniki graficzne
- Obsługa HDMI 2.1 z maks. rozdzielczością do 4K x 2K (4096x2160) przy 60Hz
- Obsługa DisplayPort 1.4 z maks. rozdzielczością do 5K (5120x2880) przy 120Hz
- Obsługa Auto Lip Sync, Deep Color (12bpc), xvYCC i HBR (High Bit Rate Audio) z portami HDMI 2.1 (Wymagany monitor zgodny z HDMI)
- Obsługa HDR (High Dynamic Range) z HDMI 2.1
- Obsługa portów HDCP 2.3 z HDMI 2.1 i DisplayPort 1.4
- Obsługa odtwarzania 4K Ultra HD (UHD) z portami HDMI 2.1 i DisplayPort 1.4
- Obsługa Microsoft PlayReady®

**Audio**

- Dźwięk HD 7.1 CH (kodek audio Realtek ALC887/897)
- Obsługa zabezpieczenia p9rzed przepięciami

**LAN**

- 1 x PCIE Gigabit LAN 10/100/1000 Mb/s
- Realtek RTL8111H
- Obsługa Wake-On-LAN
- Obsługa zabezpieczenia przed wyładowaniami atmosferycznymi/ESD
- Obsługa Energy Efficient Ethernet 802.3az
- Obsługa PXE

**Tylny panel****Wejścia/****Wyjścia**

- 1 x port myszy/klawiatury PS/2
- 1 x port HDMI
- 1 x DisplayPort 1.4
- 4 x porty USB 3.2 Gen1 (Obsługa zabezpieczenia ESD)
- 2 x porty USB 2.0 (Obsługa zabezpieczenia ESD)
- 1 x port LAN RJ-45 z LED (LED ACT/LINK i LED SPEED)
- Gniazda audio HD: Wejście liniowe / Głośnik przedni / Mikrofon

## Przechowywanie

- 4 x złącza SATA3 6,0 Gb/s, obsługa RAID (RAID 0, RAID 1 i RAID 10), NCQ, AHCI i Hot Plug\*
- \* Ścieżki współdzielone przez M2\_2 i SATA3\_3\_4. Jeżeli którakolwiek z nich jest używana, pozostała zostanie wyłączona.
- 1 x gniazdo Ultra M.2 (M2\_1), obsługa Key M typu 2280 modułu M.2 PCI Express do Gen3 x4 (32 Gb/s)\*\*
- 1 x gniazdo Ultra M.2 (M2\_2), obsługa Key M typu 2280 modułu M.2 SATA3 6,0 Gb/s i modułu M.2 PCI Express do Gen3 x2 (16 Gb/s)\*\*
- \*\* Obsługa SSD NVMe, jako dysków rozruchowych
- \*\* Obsługa ASRock U.2 Kit

## Złącze

- 1 x złącze główkowe SPI TPM
- 1 x dioda LED zasilania i złącze główkowe głośnika
- 2 x złącza główkowe LED RGB
- \* Obsługa łącznie do 12V/3A, pasek LED 36W
- 2 x adresowalne złącza główkowe LED
- \* Obsługa łącznie do 5V/3A, pasek LED 15W
- 1 x złącze wentylatora CPU (4-pinowe)
- \* Złącze wentylatora CPU obsługuje wentylator CPU maksymalnym prądem zasilania wentylatora 1A (12W).
- 3 x złącza wentylatora obudowy/pompy wodnej (4-pinowe) (Inteligentne sterowanie prędkością obrotową wentylatora)
- \* Złącze wentylatora obudowy/pompy wodnej obsługuje wentylator układu chłodzenia maksymalnym prądem zasilania wentylatora 2A (24W).
- \* CHA\_FAN1/WP, CHA\_FAN2/WP i CHA\_FAN3/WP może automatycznie wykrywać, jeśli używany jest wentylator 3-pinowy lub 4-pinowy.
- 1 x 24 pinowe złącze zasilania ATX
- 1 x 8 pinowe złącze zasilania 12 V
- 1 x złącze audio na panelu przednim
- 2 x złącza główkowe USB 2.0 (Obsługa 4 portów USB 2.0) (Obsługa zabezpieczenia ESD)
- 1 x porty główkowe USB 3.2 Gen1 (Obsługa 2 portów USB 3.2 Gen1) (Obsługa zabezpieczenia ESD)



**Funkcja BIOS**

- Obsługa starszych wersji BIOS AMI UEFI z GUI
- Obsługa “Plug and Play”
- Zgodność zdarzeń wybudzania z ACPI 5.1
- Obsługa bezworkowa
- Obsługa SMBIOS 2.3
- Wiele regulacji napięcia CPU, CPU VDDCR\_SOC, DRAM, +1,8VSB

**Monitor sprzętu**

- Wykrywanie temperatury: CPU, wentylatory obudowy/pompy wodnej
- Obrotomierz wentylatora: CPU, wentylatory obudowy/pompy wodnej
- Cichy wentylator (Automatyczna regulacja prędkości obrotowej wentylatora obudowy przez temperaturę CPU): CPU, wentylatory obudowy/pompy wodnej
- Kontrola wielu prędkości obrotowych wentylatora: CPU, wentylatory obudowy/pompy wodnej
- Monitorowanie napięcia: +12V, +5V, +3,3V, CPU Vcore, CPU VDDCR\_SOC, DRAM, VPPM, +1,8V

**System operacyjny**

- Microsoft® Windows® 10 64-bitowy

**Certyfikaty**

- FCC, CE
- Gotowość do obsługi ErP/EuP (Wymagane zasilanie z gotowością obsługi ErP/EuP)

\* Dla uzyskania szczegółowej informacji o produkcie, należy odwiedzić naszą stronę internetową:  
<http://www.asrock.com>



Należy pamiętać, że przetaktowywanie jest związane z pewnym ryzykiem, włącznie z regulacją ustawień w BIOS, zastosowaniem Untied Overclocking Technology lub używaniem narzędzi przetaktowywania innych firm. Przetaktowywanie może wpływać na stabilność systemu lub nawet powodować uszkodzenie komponentów i urządzeń systemu. Powinno to zostać zrobione na własne ryzyko i koszt. Nie odpowiadamy za możliwe uszkodzenia spowodowane przetaktowywaniem.

# 1 개요

ASRock A520M Phantom Gaming 4 마더보드를 구입해 주셔서 감사합니다. 이 마더보드는 ASRock의 일관되고 엄격한 품질관리 하에 생산되어 신뢰성이 우수합니다. 품질과 내구성에 대한 ASRock의 기준에 부합하는 우수한 성능과 견고한 설계를 제공합니다.



마더보드 규격과 BIOS 소프트웨어를 업데이트할 수도 있기 때문에, 이 문서의 내용은 예고 없이 변경될 수 있습니다. 이 설명서가 변경될 경우, 업데이트된 버전은 ASRock의 웹사이트에서 추가 통지 없이 제공됩니다. 이 마더보드와 관련하여 기술적 지원이 필요한 경우, 당사의 웹사이트를 방문하여 사용 중인 모델에 대한 구체적 정보를 구하십시오. ASRock의 웹사이트에서는 최신 VGA 카드와 CPU 지원 목록도 찾을 수 있습니다. ASRock 웹사이트 <http://www.asrock.com>.

## 1.1 포장 내용물

- ASRock A520M Phantom Gaming 4 마더보드 (Micro ATX 폼 팩터)
- ASRock A520M Phantom Gaming 4 간편 설치 안내서
- ASRock A520M Phantom Gaming 4 지원 CD
- I/O 패널 실드 1 개
- 시리얼 ATA (SATA) 데이터 케이블 2 개 (선택 품목)
- M.2 소켓용 나사 2 개 (선택 품목)

## 1.2 규격

### 플랫폼

- Micro ATX 폼 팩터
- 솔리드 콘덴서 구조
- 2 온스 구리 PCB

### CPU

- Ryzen™ 그래픽 프로세서 (3000 및 4000 시리즈 프로세서) 를 탑재한 3 세대 AMD AM4 Ryzen™/Ryzen™ 지원 이상을 지원합니다.\*
- \* AMD Ryzen™ 5 3400G 및 Ryzen™ 3 3200G 와 호환되지 않음
- Digi Power design
- 8 개 전원 위상 구조

### 칩세트

- AMD A520

### 메모리

- 듀얼 채널 DDR4 메모리 기술
- DDR4 DIMM 슬롯 4 개
- AMD Ryzen 시리즈 CPU (Matisse) 는 DDR4 4533+(OC)/4466(OC)/4400(OC)/4333(OC)/4266(OC)/4200(OC)/4133(OC)/4000(OC)/3866(OC)/3800(OC)/3733(OC)/3600(OC)/3466(OC)/3200/2933/2667/2400/2133 ECC 및 비 ECC, 비버퍼링 메모리를 지원합니다.\*
- AMD Ryzen 시리즈 APU(Renoir) 는 DDR4 4733+(OC)/4666(OC)/4600(OC)/4533(OC)/4466(OC)/4400(OC)/4333(OC)/4266(OC)/4200(OC)/4133(OC)/4000(OC)/3866(OC)/3800(OC)/3733(OC)/3600(OC)/3466(OC)/3200/2933/2667/2400/2133 및 비 ECC, 비버퍼링 메모리를 지원합니다.\*
- \* 추가 정보를 원하시면 ASRock 웹사이트에 있는 메모리 지원 목록을 참조하십시오. (<http://www.asrock.com/>)
- \* DDR4 UDIMM 최대 주파수 지원은 22 페이지를 참조하십시오.
  - 시스템 메모리 최대 용량 : 128GB
  - Extreme Memory Profile(XMP) 메모리 모듈 지원
  - DIMM 슬롯에 15μ Gold Contact 장착

### 확장 슬롯

- PCI Express 3.0 x16 슬롯 2 개 (PCIe1: x16 모드, x2 모드)\*
- \* NVMe SSD 를 부팅 디스크로 사용 가능하도록 지원
- PCI Express 3.0 x1 슬롯 1 개

## 그래픽

- Ryzen Series APU 의 통합형 AMD Radeon™ Vega Series 그래픽 \*
- \* 실제 지원은 CPU 에 따라 다를 수 있음
- DirectX 12, Pixel Shader 5.0
- 기본 공유 메모리는 2GB 입니다 . 최대 공유 메모리는 16GB 까지 지원됩니다 .
- \* 최대 공유 메모리로 16GB 를 사용하려면 32GB 의 시스템 메모리가 설치되어 있어야 합니다 .
- 이중 그래픽 출력 : 독립적 디스플레이 컨트롤러로 HDMI 및 DisplayPort 1.4 포트 지원
- HDMI 2.1 지원 ( 최대 해상도 4K x 2K (4096x2160) @ 60Hz)
- DisplayPort 1.4 지원 ( 최대 해상도 5K(5120x2880) @ 120Hz)
- Auto Lip Sync, Deep Color (12bpc), xvYCC 및 HBR (High Bit Rate Audio)(HDMI 2.1 포트 포함) 지원 (HDMI 호환 모니터 필요)
- HDMI 2.1 에서 HDR( 높은 동적 범위 ) 를 지원합니다 .
- HDCP 2.3(HDMI 2.1 및 DisplayPort 1.4 포트 포함) 지원
- HDMI 2.1 및 DisplayPort 1.4 포트를 이용한 4K Ultra HD(UHD) 재생 지원
- Microsoft PlayReady® 지원

## 오디오

- 7.1 CH HD 오디오 (Realtek ALC887/897 오디오 코덱)
- 서비 보호 지원

## LAN

- PCIE 1 개 , Gigabit LAN 10/100/1000 Mb/s
- Realtek RTL8111H
- Wake-On-LAN 지원
- 번개 /ESD 보호 지원
- 절전형 이더넷 802.3az 지원
- PXE 지원

## 후면 패널 I/O

- PS/2 마우스 / 키보드 포트 1 개
- HDMI 포트 1 개
- DisplayPort 1.4 1 개
- USB 3.2 Gen1 포트 4 개 (ESD 보호 지원)
- USB 2 포트 2 개 (ESD 보호 지원)
- LED 장착 RJ-45 LAN 포트 1 개 (ACT/LINK LED 및 SPEED LED)
- HD 오디오 잭 : 라인 입력 / 전면 스피커 / 마이크

## 저장 장치

- SATA3 4 Gb/s 커넥터 6 개가 RAID(RAID 0, RAID 1 및 RAID 10), NCQ, AHCI 및 핫 플러그를 지원합니다 \*
- \* M2\_2, 및 SATA3\_3\_4 가 레인을 공유합니다. 이들 중 하나가 사용 중인 경우, 나머지가 비활성화됩니다.
- Ultra M.2 소켓 (M2\_1) 1 개, Gen3 까지의 M 키 타입 2280 M.2 PCI Express 모듈 4 개 지원 (32 Gb/s)\*\*
- M.2 소켓 (M2\_2) 1 개, M 키 타입 2280 M.2 SATA3 6.0 Gb/s 모듈 및 Gen3 M.2 PCI Express 모듈을 2 개 (16 Gb/s) 까지 지원 \*\*
- \*\* NVMe SSD 를 부팅 디스크로 사용 가능하도록 지원
- \*\* ASRock U.2 키트 지원

## 커넥터

- SPI TPM 헤더 1 개
- 전원 LED 및 스피커 헤더 1 개
- RGB LED 헤더 2 개
- \* 전체 최대 12V/3A, 36W LED 스트립 지원
- 주소 지정 가능한 LED 헤더 2 개
- \* 전체 최대 5V/3A, 15W LED 스트립 지원
- CPU 팬 커넥터 (4 핀) 1 개
- \* CPU 팬 커넥터는 팬 전력이 최대 1A(12W) 인 CPU 팬을 지원합니다.
- 새시 / 워터 펌프 팬 커넥터 (4 핀) 3 개 (스마트 팬 속도 제어)
- \* 새시 / 워터 펌프 팬은 팬 전력이 최대 2A(24W) 인 수냉식 쿨러 팬을 지원합니다.
- \* 3 핀 또는 4 핀 팬이 사용 중인 경우, CHA\_FAN1/WP, CHA\_FAN2/WP 과 CHA\_FAN3/WP 가 자동으로 감지할 수 있습니다.
- 24 핀 ATX 전원 커넥터 1 개
- 8 핀 12V 전원 커넥터 1 개
- 전면 패널 오디오 커넥터 1 개
- USB 2.0 헤더 2 개 (USB 2.0 포트 4 개 지원) (ESD 보호 지원)
- USB 3.2 Gen1 헤더 1 개 (USB 3.2 Gen1 포트 2 개 지원) (ESD 보호 지원)

### BIOS 기능

- GUI 지원을 제공하는 AMI UEFI 적합형 BIOS
- “플러그 앤드 플레이” 지원
- ACPI 5.1 준수 웨이크 업 이벤트
- 점퍼 프리 지원
- SMBIOS 2.3 지원
- CPU, CPU VDDCR\_SOC, DRAM, +1.8VSB 전압 다중 조정

### 하드웨어 모니터

- 온도 감지 : CPU, 새시 / 워터 펌프 팬
- 팬 타코미터 : CPU, 새시 / 워터 펌프 팬
- 저소음 팬 (CPU 온도에 의한 새시 팬 속도 자동 조절): CPU, 새시 / 워터 펌프 팬
- 팬 다중 속도 제어 : CPU, 새시 / 워터 펌프 팬
- 전압 모니터링 : +12V, +5V, +3.3V, CPU Vcore, CPU VDDCR\_SOC, DRAM, VPPM, +1.8V

### OS

- Microsoft® Windows® 10 64- 비트

### 인증

- FCC, CE
- ErP/EuP 사용 가능 (ErP/EuP 사용 가능 전원공급장치 필요)

\* 자세한 제품 정보에 대해서는 당사 웹사이트를 참조하십시오 : <http://www.asrock.com>



BIOS 설정을 조정하거나 Untied Overclocking Technology 를 적용하거나 타업체의 오버클로킹 도구를 사용하는 것을 포함하는 오버클로킹에는 어느 정도의 위험이 따른다는 것을 유념하십시오. 오버클로킹은 시스템 안정성에 영향을 주거나 심지어 시스템의 구성 요소와 장치에 손상을 입힐 수도 있습니다. 오버클로킹은 사용자 스스로 위험과 비용을 감수하고 해야 합니다. 당사는 오버클로킹에 의해 발생할 수 있는 손상에 대해서 책임이 없습니다.

# 1 はじめに

ASRock A520M Phantom Gaming 4 マザーボードをお買い上げ頂きありがとうございます。ASRock の製品は一貫した厳格な品質管理の下で製造されており、優れた品質と耐久性を兼ね備えつつ、優れたパフォーマンスを提供致します。



マザーボードの仕様と BIOS ソフトウェアは更新されることがあるため、このマニュアルの内容は予告なしに変更することがあります。このマニュアルの内容に変更があった場合には、更新されたバージョンは、予告なく ASRock のウェブサイトから入手できるようになります。このマザーボードに関する技術的なサポートが必要な場合には、ご使用のモデルについての詳細情報を、当社のウェブサイトで参照ください。ASRock のウェブサイトでは、最新の VGA カードおよび CPU サポート一覧もご覧になれます。ASRock ウェブサイト <http://www.asrock.com>

## 1.1 パッケージの内容

- ASRock A520M Phantom Gaming 4 マザーボード(マイクロ ATX フォームファクター)
- ASRock A520M Phantom Gaming 4 クイックインストールガイド
- ASRock A520M Phantom Gaming 4 サポート CD
- 1 x I/O パネルシールド
- 2 x シリアル ATA (SATA) データケーブル(オプション)
- 2 x M.2 ソケット用ねじ(オプション)

## 1.2 仕様

### プラットフォーム

- マイクロ ATX フォームファクター
- 固体コンデンサ設計
- 2 オンスのコパー製 PCB

### CPU

- Ryzen™ グラフィックスプロセッサ (3000 および 4000 シリーズプロセッサ) と共に第 3 世代以降の AMD AM4 Ryzen™/ Ryzen™ に対応します \*

\* AMD Ryzen™ 5 3400G および Ryzen™ 3 3200G と互換性はありません

- デジタル電源設計
- 8 電源フェーズ設計

### チップセット

- AMD A520

### メモリ

- デュアルチャンネル DDR4 メモリ機能
- 4 x DDR4 DIMM スロット
- AMD Ryzen シリーズ CPU (Matisse) は、DDR4 4533+(OC)/4466(OC)/4400(OC)/4333(OC)/4266(OC)/4200(OC)/4133(OC)/4000(OC)/3866(OC)/3800(OC)/3733(OC)/3600(OC)/3466(OC)/3200/2933/2667/2400/2133 ECC および非 ECC、アンバッファードメモリに対応します \*
- AMD Ryzen シリーズ APU (Renoir) は、DDR4 4733+(OC)/4666(OC)/4600(OC)/4533(OC)/4466(OC)/4400(OC)/4333(OC)/4266(OC)/4200(OC)/4133(OC)/4000(OC)/3866(OC)/3800(OC)/3733(OC)/3600(OC)/3466(OC)/3200/2933/2667/2400/2133 ECC および非 ECC、アンバッファードメモリに対応します \*

\* 詳細については、ASRock ウェブサイトのメモリーサポート一覧を参照してください。( <http://www.asrock.com/> )

\* DDR4 UDIMM 最大周波数サポートについては 22 ページを参照してください。

- システムメモリの最大容量: 128GB
- Extreme Memory Profile (XMP) メモリモジュールに対応します
- DIMM スロットに 15μ ゴールドコンタクトを採用



**拡張スロット**

- 2 x PCI Express 3.0 x16 スロット (PCIe1: x16 モード、PCIe3: x2 モード)\*
- \* 起動ディスクとして NVMe SSD に対応
- 1 x PCI Express 3.0 x1 スロット

**グラフィックス**

- AMD Radeon™ Vega シリーズグラフィックスを Ryzen シリーズ APU に統合\*
- \* 実際のサポートは CPU によって異なることがあります
- DirectX 12, Pixel Shader 5.0
- 共有メモリはデフォルトでは 2GB に設定されています。最大共有メモリは 16GB まで対応します。
- \* 最大共有メモリが 16GB の場合は、32GB のシステムメモリがインストールされていなければなりません。
- デュアルグラフィックス出力: 独立したディスプレイコントローラで HDMI ポートと DisplayPort 1.4 ポートに対応
- HDMI 2.1 テクノロジーに対応、最大解像度 4K x 2K (4096x2160) @ 60Hz
- 最大 5K (5120x2880、120Hz 時) の解像度で DisplayPort 1.4 に対応します
- HDMI 2.1 ポートでオートリップシンク、ディープカラー (12bpc)、xvYCC、および、HBR (高ビットレートオーディオ) に対応 (HDMI 対応モニターが必要です)
- HDMI 2.1 の高ダイナミックレンジ (HDR) に対応
- HDMI 2.1 ポートと DisplayPort 1.4 ポートで HDCP 2.3 に対応
- HDMI 2.1 ポートと DisplayPort 1.4 ポートで 4K Ultra HD (UHD) 再生に対応
- Microsoft PlayReady® に対応

**オーディオ**

- 7.1 CH HD オーディオ (Realtek ALC887/897 Audio Codec)
- サージ保護に対応

**LAN**

- PCIE x1 ギガビット LAN 10/100/1000 Mb/s
- Realtek RTL8111H
- Wake-On-LAN(ウェイク オン ラン)に対応
- 雷 / 静電気放電 (ESD) 保護に対応
- エネルギー効率のよいイーサネット 802.3az をサポート
- PXE をサポート

**リアパネル I/O**

- 1 x PS/2 マウス / キーボードポート
- 1 x HDMI ポート
- 1 x DisplayPort 1.4
- 4 x USB 3.2 Gen1 ポート (静電気放電 (ESD) 保護に対応)
- 2 x USB 2.0 ポート (静電気放電 (ESD) 保護に対応)
- LED 付き 1 x RJ-45 LAN ポート (ACT/LINK LED と SPEED LED)
- HD オーディオジャック : ラインイン / フロントスピーカー / マイク

**ストレージ**

- 4 x SATA3 6.0 Gb/s コネクタ, RAID (RAID 0, RAID 1, RAID 10)、NCQ、AHCI およびホットプラグ機能に対応 \*
- \* M2\_2 と SATA3\_3\_4 はレーンを共有します。いずれかが使用されている場合は、他の 1 つは無効になります。
- 1 x Ultra M.2 ソケット (M2\_1)、最大 Gen3 x4 (32 Gb/s) までの M Key タイプ 2280 M.2 PCI Express モジュールに対応 \*\*
- 1 x M.2 ソケット (M2\_2)、M Key タイプ 2280 M.2 SATA3 6.0 Gb/s モジュールと最大 Gen3 x2 (16 Gb/s) までの M.2 PCI Express モジュールに対応 \*\*
- \*\* 起動ディスクとして NVMe SSD に対応
- \*\* ASRock U.2 キットに対応

**コネクタ**

- 1 x SPI TPM ヘッダー
- 1 x 電源 LED とスピーカーヘッダー
- 2 x RGB LED ヘッダー
- \* 合計 12V/3A、36W までの LED ストリップに対応
- 2 x アドレスラブル LED ヘッダー
- \* 合計 5V/3A、15W までの LED ストリップに対応
- 1 x CPU ファンコネクタ (4 ピン)
- \* CPU ファンコネクタは最大 1A (12W) の電力の CPU ファンに対応します。

- 3 x シャーシ / ウォーターポンプファンコネクタ(4ピン)(スマートファン速度制御)
- \* シャーシ / ウォーターポンプファンは最大 2A (24W) の出力のウォータークーラーに対応します。
- \* CHA\_FAN1/WP, CHA\_FAN2/WP および CHA\_FAN3/WP は 3ピンまたは 4ピンファンが使用されているかどうかを自動検出できます。
  - 1 x 24ピン ATX 電源コネクタ
  - 1 x 8ピン 12V 電源コネクタ
  - 1 x 前面パネルオーディオコネクタ
  - 2 x USB 2.0 ヘッダー(4つの USB 2.0 ポートに対応)(静電気放電 (ESD) 保護に対応)
  - 1 x USB 3.2 Gen1 ヘッダー(2つの USB 3.2 Gen1 ポートに対応)(静電気放電 (ESD) 保護に対応)

**BIOS 機能**

- AMI UEFI Legal BIOS、GUI サポート付き
- 「プラグアンドプレイ」をサポート
- ACPI 5.1 準拠のウェイクアップイベント
- ジャンパーフリーをサポート
- SMBIOS 2.3 サポート
- CPU、CPU、VDDCR\_SOC、DRAM、+1.8VSB 電圧マルチ調整

**ハードウェア  
モニター**

- 温度センシング: CPU、シャーシ / ウォーターポンプファン
- ファンタコメータ: CPU、シャーシ / ウォーターポンプファン
- 静音ファン(CPU 温度に従ってシャーシファン速度を自動調整): CPU、シャーシ / ウォーターポンプファン
- ファンマルチ速度制御: CPU、シャーシ / ウォーターポンプファン
- 電圧監視: +12V、+5V、+3.3V、CPU Vcore、CPU VDDCR\_SOC、DRAM、VPPM、+1.8V

**OS**

- Microsoft® Windows® 10 64-bit

**認証**

- FCC、CE
- ErP/EuP Ready(ErP/EuP 対応電源供給装置が必要です)

\* 商品詳細については、当社ウェブサイトをご覧ください。<http://www.asrock.com>



BIOS 設定の調整、アンタイドオーバークロックテクノロジーの適用、サードパーティのオーバークロックツールの使用などを含む、オーバークロックには、一定のリスクを伴いますのでご注意ください。オーバークロックするとシステムが不安定になったり、システムのコンポーネントやデバイスが破損することがあります。ご自分の責任で行ってください。弊社では、オーバークロックによる破損の責任は負いかねますのでご了承ください。

# 1 简介

感谢您购买华擎 A520M Phantom Gaming 4 主板，这是按照华擎一贯严格质量控制标准生产的性能可靠的主板。它提供符合华擎质量和耐久性承诺的精良设计和卓越性能。



由于主板规格和 BIOS 软件可能已更新，因此，本文档的内容可能会随时更改，恕不另行通知。如果本文档有任何修改，则更新的版本将发布在华擎网站上，我们不会另外进行通知。如果您需要与此主板相关的技术支持，请访问我们的网站以具体了解所用型号的信息。您也可以在华擎网站上找到最新 VGA 卡和 CPU 支持列表。华擎网站 <http://www.asrock.com>。

## 1.1 包装清单

- 华擎 A520M Phantom Gaming 4 主板（Micro ATX 规格尺寸）
- 华擎 A520M Phantom Gaming 4 快速安装指南
- 华擎 A520M Phantom Gaming 4 支持光盘
- 1 x I/O 面板
- 2 x 串行 ATA (SATA) 数据线（选购）
- 2 x 螺丝（供 M.2 插座使用）（选购）

## 1.2 规格

### 平台

- Micro ATX 规格尺寸
- 稳固的电容器设计
- 2 盎司纯铜电路板

### CPU

- 支持第 3 代 AMD AM4 Ryzen™ / 将来的 AMD Ryzen™ 处理器（3000 和 4000 系列处理器）\*
- \* 不兼容 AMD Ryzen™ 5 3400G 和 Ryzen™ 3 3200G
- Digi Power design
- 8 电源相设计

### 芯片集

- AMD A520

### 内存

- 双通道 DDR4 内存技术
- 4 x DDR4 DIMM 槽
- AMD Ryzen 系列 CPU (Matisse) 支持 DDR4 4533+(OC)/4466(OC)/4400(OC)/4333(OC)/4266(OC)/4200(OC)/4133(OC)/4000(OC)/3866(OC)/3800(OC)/3733(OC)/3600(OC)/3466(OC)/3200/2933/2667/2400/2133 ECC 及非 ECC，非缓冲内存 \*
- AMD Ryzen 系列 APU (Renoir) 支持 DDR4 4733+(OC)/4666(OC)/4600(OC)/4533(OC)/4466(OC)/4400(OC)/4333(OC)/4266(OC)/4200(OC)/4133(OC)/4000(OC)/3866(OC)/3800(OC)/3733(OC)/3600(OC)/3466(OC)/3200/2933/2667/2400/2133 ECC 及非 ECC，非缓冲内存 \*
- \* 请参阅华擎网站上的 Memory Support List（内存支持列表）了解详情。（<http://www.asrock.com/>）
- \* 请参考第 22 页了解 DDR4 UDIMM 最大支持频率。
- 支持系统内存最大容量：128GB
- 支持 Extreme Memory Profile (XMP) 内存模块
- DIMM 插槽中 15μ 金触点

### 扩充槽

- 2 x PCI Express 3.0 x16 槽（PCIe1: x16 模式；PCIe3: x2 模式）\*
- \* 支持 NVMe SSD 用作启动盘
- 1 x PCI Express 3.0 x1 槽

## 图形

- Ryzen 系列 APU 中的集成 AMD Radeon™ Vega 系列图形 \*
- \* 实际支持可能视 CPU 而变化
- DirectX 12、Pixel Shader 5.0
- 默认共享内存 2GB。最大共享内存达 16GB。
- \* 最大共享内存 16GB 需要安装 32GB 系统内存。
- 双图形输出：通过独立显示控制器支持 HDMI 和 DisplayPort 1.4 端口
- 支持 HDMI 2.1，60Hz 时最大分辨率达 4K x 2K (4096x2160)
- 支持 DisplayPort 1.4，120Hz 时最大分辨率达 5K (5120x2880)
- 通过 HDMI 2.1 端口（需要兼容的 HDMI 显示器）支持 Auto Lip Sync、Deep Color (12bpc)、xvYCC 和 HBR（高动态范围音频）
- 通过 HDMI 2.1 支持 HDR（高动态范围）
- 通过 HDMI 2.1 和 DisplayPort 1.4 端口支持 HDCP 2.3
- 通过 HDMI 2.1 和 DisplayPort 1.4 端口支持支持 4K 超高清 (UHD) 播放
- 支持 Microsoft PlayReady®

## 音频

- 7.1 CH 高清音频（Realtek ALC887/897 音频编解码器）
- 支持电涌保护

## LAN

- PCIe x1 Gigabit LAN 10/100/1000 Mb/s
- Realtek RTL8111H
- 支持 Wake-On-LAN（网上唤醒）
- 支持雷电 /ESD 保护
- 支持高效以太网 802.3az
- 支持 PXE

## 后面板 I/O

- 1 x PS/2 鼠标 / 键盘端口
- 1 x HDMI 端口
- 1 x DisplayPort 1.4
- 4 x USB 3.2 Gen1 端口（支持 ESD 保护）
- 2 x USB 2.0 端口（支持 ESD 保护）
- 1 x RJ-45 LAN 端口，带 LED（ACT/LINK LED 和 SPEED LED）
- 高清音频插孔：线路输入 / 前扬声器 / 麦克风

## 存储

- 4 x SATA3 6.0 Gb/s 接口，支持 RAID (RAID 0、RAID 1 和 RAID 10)、NCQ、AHCI 和热插拔 \*
- \* M2\_2 和 SATA3\_3\_4 共享巷道。如果其中一个在使用，则另一个将被禁用。
- 1 x 超级 M.2 接口 (M2\_1)，支持 M Key 类型 2280 M.2 PCI Express 类型模块 (最高 Gen3 x4，32 Gb/s) \*\*
- 1 x M.2 接口 (M2\_2)，支持 2280 M.2 SATA3 6.0 Gb/s M Key 类型模块和 M.2 PCI Express 模块 (最高 Gen3 x2 (16 Gb/s)) \*\*
- \*\* 支持 NVMe SSD 用作启动盘
- \*\* 支持华擎 U.2 套件

## 接口

- 1 x SPI TPM 接脚
- 1 x 电源 LED 和扬声器接脚
- 2 x RGB LED 接头
- \* 总共支持最高 12V/3A, 36W LED 灯条
- 2 x 可寻址 LED 接脚
- \* 总共支持最高 5V/3A, 15W LED 灯条
- 1 x CPU 风扇接口 (4 针)
- \* CPU 风扇接口支持最高 1A (12W) 功率的 CPU 风扇。
- 3 x 机箱 / 水泵风扇接口 (4 针) (智能风扇速度控制)
- \* 机箱 / 水泵风扇支持最高 2A (24W) 功率的水冷风扇。
- \* CHA\_FAN1/WP、CHA\_FAN2/WP 和 CHA\_FAN3/WP 可以自动检测 3 针脚或 4 针脚风扇是否在使用。
- 1 x 24 针 ATX 电源接口
- 1 x 8 针 12V 电源接口
- 1 x 前面板音频接口
- 2 x USB 2.0 接脚 (支持 4 个 USB 2.0 端口，支持 ESD 保护)
- 1 x USB 3.2 Gen1 接脚 (支持 2 个 USB 3.2 Gen1 端口，支持 ESD 保护)

## BIOS 功能特点

- AMI UEFI Legal BIOS，支持 GUI
- 支持“即插即用”
- ACPI 5.1 兼容唤醒事件
- 支持免跳线 (jumperfree)
- 支持 SMBIOS 2.3
- CPU、CPU VDDCR\_SOC、DRAM、+1.8VSB 电压多次调整 (Voltage Multi-adjustment)



**硬件监控**

- 温度感测：CPU、机箱 / 水泵风扇
- 风扇转速计：CPU、机箱 / 水泵风扇
- 静音风扇（根据 CPU 温度自动调整机箱风扇速度）：  
CPU、机箱 / 水泵风扇
- 风扇多种速度控制：CPU、机箱 / 水泵风扇
- 电压监控：+12V、+5V、+3.3V、CPU Vcore、  
CPU VDDCR\_SOC、DRAM、VPPM、+1.8V

**操作系统**

- Microsoft® Windows® 10 64-bit

**认证**

- FCC、CE
- ErP/EuP 支持（需要支持 ErP/EuP 的电源）

\* 有关详细产品信息，请访问我们的网站：<http://www.asrock.com>



须认识到超频会有一定风险，包括调整 BIOS 设置，应用“自由超频技术”，或使用第三方超频工具。超频可能会影响到系统的稳定性，甚至对系统的组件和设备造成损坏。执行这项工作您应自担风险和费用。我们对由于超频而造成的损坏概不负责。

# 1 簡介

感謝您購買華擎 A520M Phantom Gaming 4 主機板，本主機板經華擎嚴格品質製作，是一套讓人信賴的可靠產品。本產品採耐用設計所展現的優異效能，完全符合華擎對品質及耐用度的承諾。



由於主機板規格及 BIOS 軟體可能會更新，所以本文件內容如有變更，恕不另行通知。如本文件有任何修改，可至華擎網站逕行取得更新版本，不另外通知。若您需要與本主機板相關的技術支援，請上我們的網站瞭解有關您使用機型的特定資訊。您也可以到華擎網站找到最新的 VGA 卡及 CPU 支援清單。華擎網站 <http://www.asrock.com>。

## 1.1 包裝內容

- 華擎 A520M Phantom Gaming 4 主機板（Micro ATX 尺寸）
- 華擎 A520M Phantom Gaming 4 快速安裝指南
- 華擎 A520M Phantom Gaming 4 支援光碟
- 1 x I/O 面板外罩
- 2 x Serial ATA (SATA) 資料纜線（選用）
- 2 x 螺絲（適用於 M.2 插座）（選用）

## 1.2 規格

- 平台
- Micro ATX 尺寸
  - 固態電容設計
  - 2oz 銅製 PCB

- CPU
- 支援第 3 代 AMD AM4 Ryzen™ / 未來的 AMD Ryzen™ 處理器 (3000 與 4000 系列處理器) \*
  - \* 不相容於 AMD Ryzen™ 5 3400G 與 Ryzen™ 3 3200G
  - Digi Power design
  - 8 電源相位設計

- 晶片組
- AMD A520

- 記憶體
- 雙通道 DDR4 記憶體技術
  - 4 x DDR4 DIMM 插槽
  - AMD Ryzen 系列 CPU (Matisse) 支援 DDR4 4533+(OC)/4466(OC)/4400(OC)/4333(OC)/4266(OC)/4200(OC)/4133(OC)/4000(OC)/3866(OC)/3800(OC)/3733(OC)/3600(OC)/3466(OC)/3200/2933/2667/2400/2133 ECC & 非 ECC、無緩衝記憶體 \*
  - AMD Ryzen 系列 APU (Renoir) 支援 DDR4 4733+(OC)/4666(OC)/4600(OC)/4533(OC)/4466(OC)/4400(OC)/4333(OC)/4266(OC)/4200(OC)/4133(OC)/4000(OC)/3866(OC)/3800(OC)/3733(OC)/3600(OC)/3466(OC)/3200/2933/2667/2400/2133 ECC & 非 ECC、無緩衝記憶體 \*
  - \* 如需更多資訊，請參閱華擎網站上的記憶體支援表。  
(<http://www.asrock.com/>)
  - \* 關於 DDR4 UDIMM 最高頻率支援，請參閱第 22 頁。
    - 最大系統記憶體容量：128GB
    - 支援 Extreme Memory Profile (XMP) 記憶體模組
    - 15μ 特厚鍍金插槽

- 擴充插槽
- 2 x PCI Express 3.0 x16 插槽 (PCIe1 : x16 模式 ; PCIe3 : x2 模式) \*
  - \* 支援 NVMe SSD 作為開機磁碟
  - 1 x PCI Express 3.0 x1 插槽

## 顯示卡

- 整合式 AMD Radeon™ Vega Series Graphics 內建於 Ryzen 系列 APU\*
- \* 實際支援可能隨 CPU 改變
- DirectX 12、Pixel Shader 5.0
- 預設共用記憶體 2GB。最大共用記憶體達 16GB。
- \* 最大共用記憶體 16GB 需要安裝 32GB 系統記憶體。
- 雙圖形輸出：透過獨立顯示控制器支援 HDMI 及 DisplayPort 1.4 連接埠
- 最高支援 4K x 2K (4096x2160) @ 60Hz 解析度的 HDMI 2.1
- 支援最高達 5K (5120x2880) @ 120Hz 解析度的 DisplayPort 1.4
- 支援使用 HDMI 2.1 連接埠（需相容於 HDMI 顯示器）的 Auto Lip Sync、Deep Color (12bpc)、xvYCC 及 HBR（高位元率音訊）
- 使用 HDMI 2.1 支援 HDR（高動態範圍）
- 支援含 HDMI 2.1 及 DisplayPort 1.4 連接埠的 HDCP 2.3
- 支援使用 HDMI 2.1 與 DisplayPort 1.4 連接埠進行 4K Ultra HD (UHD) 播放
- 支援 Microsoft PlayReady®

## 音訊

- 7.1 CH HD 音訊（Realtek ALC887/897 音訊轉碼器）
- 支援突波保護

## LAN

- PCIE x1 Gigabit LAN 10/100/1000 Mb/s
- Realtek RTL8111H
- 支援網路喚醒
- 支援雷擊／靜電保護
- 支援 802.3az EEE 節能乙太網路
- 支援 PXE

## 後面板 I/O

- 1 x PS/2 滑鼠／鍵盤連接埠
- 1 x HDMI 連接埠
- 1 x DisplayPort 1.4
- 4 x USB 3.2 Gen1 連接埠（支援靜電保護）
- 2 x USB 2.0 連接埠（支援靜電保護）
- 1 x RJ-45 LAN 連接埠，含 LED（ACT/LINK LED 及 SPEED LED）
- HD 音訊插孔：線路輸入／前置喇叭／麥克風

## 儲存裝置

- 提供 4 x SATA3 6.0 Gb/s 接頭，支援 RAID (RAID 0、RAID 1、與 RAID 10)、NCQ、AHCI 及熱插拔 \*
- \* M2\_2 及 SATA3\_3\_4 共用通道。如果任一個正在使用中，其他將會停用。
- 1 x Ultra M.2 插座 (M2\_1)，支援 M Key 型 2280 M.2 PCI Express 模組 (最高可達 Gen3 x4 (32 Gb/s)) \*\*
- 1 x M.2 插座 (M2\_2)，支援 2280 M.2 SATA3 6.0 Gb/s 模組與 M.2 PCI Express 模組 (最高可達 Gen3 x2 (16 Gb/s)) 類型 \*\*
- \*\* 支援 NVMe SSD 作為開機磁碟
- \*\* 支持華擎 U.2 套件

## 接頭

- 1 x SPI TPM 排針
- 1 x 電源 LED 及喇叭排針
- 2 x RGB LED 排針
- \* 總計最高支援 12V/3A，36W LED 條燈
- 2 x 可定址 LED 排針
- \* 總計最高支援 5V/3A，15W LED 條燈
- 1 x CPU 風扇接頭 (4-pin)
- \* CPU 風扇接頭支援最高 1A (12W) 風扇功率的 CPU 風扇。
- 3 x 機殼/水冷幫浦風扇接頭 (4-pin) (智慧型風扇速度控制)
- \* 機殼/水冷幫浦風扇接頭支援最高 2A (24W) 風扇功率的水冷風扇。
- \* 如果 3-pin 或 4-pin 風扇使用中，可自動偵測 CHA\_FAN1/WP、CHA\_FAN2/WP 和 CHA\_FAN3/WP。
- 1 x 24 pin ATX 電源接頭
- 1 x 8 pin 12V 電源接頭
- 1 x 前面板音訊接頭
- 2 x USB 2.0 排針 (支援 4 個 USB 2.0 連接埠) (支援靜電保護)
- 1 x USB 3.2 Gen1 排針 (支援 2 個 USB 3.2 Gen1 連接埠) (支援靜電保護)

## BIOS 功能

- AMI UEFI Legal BIOS 含 GUI 支援
- 支援「隨插即用」
- ACPI 5.1 符合喚醒自動開機
- 支援免跳線模式
- 支援 SMBIOS 2.3
- CPU、CPU VDDCR\_SOC、DRAM、+1.8VSB 電壓多重調整

### 硬體顯示器

- 溫度感應：CPU、機殼／水冷幫浦風扇
- 風扇轉速計：CPU、機殼／水冷幫浦風扇
- 靜音風扇（依 CPU 溫度自動調整機殼風扇速度）：  
CPU、機殼／水冷幫浦風扇
- 風扇多重速度控制：CPU、機殼／水冷幫浦風扇
- 電壓監控：+12V、+5V、+3.3V、CPU Vcore、CPU  
VDDCR\_SOC、DRAM、VPPM、+1.8V

### 作業系統

- Microsoft® Windows® 10 64-bit

### 認證

- FCC、CE
- ErP/EuP ready（須具備 ErP/EuP ready 電源供應器）

\* 如需產品詳細資訊，請上我們的網站：<http://www.asrock.com>



請務必理解，超頻可能產生某種程度的風險，其中包括調整 BIOS 中的設定、採用自由超頻技術或使用協力廠商的超頻工具。超頻可能會影響您系統的穩定性，或者甚至會對您系統的元件及裝置造成傷害。您應自行負擔超頻風險及成本。我們對於因超頻所造成的可能損害概不負責。

## Spesifikasi

### Platform

- Bentuk dan Ukuran Micro ATX
- Desain Kapasitor Solid
- PCB Tembaga 2oz

### CPU

- Mendukung AMD AM4 Ryzen™ Gen 3 / AMD Ryzen™ Prosesor masa depan (Prosesor Seri 3000 dan 4000)\*
- \* Tidak kompatibel dengan AMD Ryzen™ 5 3400G dan Ryzen™ 3 3200G
- Desain Digi Power
- Desain 8 Fase Daya

### Chipset

- AMD A520

### Memori

- Teknologi Memori DDR4 Dua Saluran
- 4 x Slot DIMM DDR4
- CPU seri AMD Ryzen (Matisse) yang mendukung memori ECC & non-ECC, tanpa buffering DDR4 4533+(OC)/4466(OC)/4400(OC)/4333(OC)/4266(OC)/4200(OC)/4133(OC)/4000(OC)/3866(OC)/3800(OC)/3733(OC)/3600(OC)/3466(OC)/3200/2933/2667/2400/2133\*
- APU seri AMD Ryzen (Renoir) yang mendukung memori ECC & non-ECC, tanpa buffering DDR4 4733+(OC)/4666(OC)/4600(OC)/4533(OC)/4466(OC)/4400(OC)/4333(OC)/4266(OC)/4200(OC)/4133(OC)/4000(OC)/3866(OC)/3800(OC)/3733(OC)/3600(OC)/3466(OC)/3200/2933/2667/2400/2133\*
- \* Lihat Daftar Dukungan Memori di situs web ASRock untuk informasi selengkapnya. (<http://www.asrock.com/>)
- \* Lihat halaman 22 untuk dukungan frekuensi maksimum DDR4 UDIMM.
- Kapasitas maksimum memori sistem: 128GB
- Mendukung modul memori Extreme Memory Profile (XMP)
- 15µ Bidang Kontak Berwarna Emas di Slot DIMM

### Slot Ekspansi

- 2 x Slot PCI Express 3.0 x16 (PCIe1: x16 mode; PCIe3: x2 mode)\*
- \* Mendukung SSD NVMe sebagai disk boot
- 1 x Slot PCI Express 3.0 x1

**Grafis**

- Grafis AMD Radeon™ Terpadu Seri Vega dalam APU Seri Ryzen\*

\* Dukungan sebenarnya mungkin beragam berdasarkan CPU

- DirectX 12, Pixel Shader 5.0
- Default memori bersama 2GB. Memori bersama maksimum mendukung hingga 16GB.

\* Memori bersama maksimum 16GB mengharuskan memori sistem 32GB terpasang.

- Output grafis ganda: Mendukung port HDMI dan DisplayPort 1.4 melalui pengontrol layar mandiri
- Mendukung HDMI 2.1 dengan resolusi maksimum hingga 4K x 2K (4096x2160) @ 60Hz
- Mendukung DisplayPort 1.4 dengan resolusi maksimum hingga 5K (5120x2880) @ 120Hz
- Mendukung Auto Lip Sync, Kedalaman Warna (12bpc), xvYCC, dan HBR (Audio High Bit Rate) dengan Port HDMI 2.1 (memerlukan monitor yang kompatibel dengan HDMI)
- Mendukung HDR (High Dynamic Range) dengan HDMI 2.1
- Mendukung HDCP 2.3 dengan Port HDMI 2.1 dan DisplayPort 1.4
- Mendukung pemutaran Ultra HD 4K (UHD) dengan Port HDMI 2.1 dan DisplayPort 1.4
- Mendukung Microsoft PlayReady®

**Audio**

- Audio HD 7.1 CH (Realtek ALC887/897 Audio Codec)
- Mendukung Perlindungan dari Lonjakan Arus

**LAN**

- 1 x PCIE Gigabit LAN 10/100/1000 Mb/s
- Realtek RTL8111H
- Mendukung Wake-On-LAN
- Mendukung Perlindungan dari Petir/ESD
- Mendukung Ethernet 802.3az Hemat Energi
- Mendukung PXE

**I/O Panel Belakang**

- 1 x Port Mouse/Keyboard PS/2
- 1 x Port HDMI
- 1 x DisplayPort 1.4
- 4 x Port USB 3.2 Gen1 (Mendukung Perlindungan dari ESD)
- 2 x Port USB 2.0 (Mendukung Perlindungan dari ESD)
- 1 x Port LAN RJ-45 dengan LED (LED ACT/LINK dan LED SPEED)
- Soket Audio HD: Saluran Masuk/Speaker Depan/Mikrofon



**Penyimpanan**

- 4 Konektor SATA3 6,0 Gb/s, mendukung RAID (RAID 0, RAID 1, dan RAID 10), NCQ, AHCI dan Hot Plug\*
- \* Lajur berbagi M2\_2 dan SATA3\_3\_4. Jika salah satunya sedang digunakan, maka yang lainnya akan dinonaktifkan.
- 1 x Soket Ultra M.2 (M2\_1), mendukung jenis modul 2280 M.2 PCI Express hingga Gen3 x4 (32 Gb/s)\*\*
- 1 x Soket M.2 (M2\_2), mendukung modul M Key tipe 2280 M.2 SATA3 6,0 Gb/s dan modul M.2 PCI Express hingga Gen3 x2 (16 Gb/s)\*\*
- \*\* Mendukung SSD NVMe sebagai disk boot
- \*\* Mendukung Kit ASRock U.2

**Konektor**

- 1 x Header SPI TPM
- 1 x Header LED Daya dan Speaker
- 2 x Header LED RGB
- \* Mendukung total Strip LED hingga 12V/3A, 36W
- 2 x Addressable LED Header
- \* Mendukung total Strip LED hingga 5V/3A, 15W
- 1 x Konektor Kipas CPU (4-pin)
- \* Konektor Kipas CPU mendukung kipas CPU dengan daya kipas maksimum 1A (12W).
- 3 x Konektor Sasis/Kipas Pompa Air (4-pin) (Kontrol Kecepatan Kipas Pintar)
- \* Chassis/Kipas Pompa Air mendukung kipas berpendingin air dengan daya kipas maksimum 2A (24W).
- \* CHA\_FAN1/WP, CHA\_FAN2/WP, dan CHA\_FAN3/WP dapat mendeteksi otomatis jika kipas 3-pin atau 4-pin sedang digunakan.
- 1 x Konektor Daya ATX 24 pin
- 1 x Konektor Daya 8 pin 12V
- 1 x Konektor Audio Panel Depan
- 2 x Header USB 2.0 (Mendukung 4 port USB 2.0) (Mendukung Perlindungan dari ESD)
- 1 x Header USB 3.2 Gen1 (Mendukung 2 port USB 3.2 Gen1) (Mendukung Perlindungan dari ESD)

**Fitur BIOS**

- AMI UEFI Legal BIOS dengan dukungan GUI
- Mendukung “Plug and Play”
- ACPI 5.1 kompatibel dengan aktivitas pengaktifan
- Mendukung jumperfree
- Dukungan SMBIOS 2.3
- CPU, CPU VDDCR\_SOC, DRAM, +1,8VSB, Penyesuaian Multi Voltase

**Monitor Perangkat Keras**

- Deteksi Suhu: Kipas CPU, Sasis, Pompa Air
- Takometer Kipas: Kipas CPU, Sasis, Pompa Air
- Kipas Hening (Penyesuaian otomatis kecepatan kipas sasis berdasarkan suhu CPU): Kipas CPU, Sasis, Pompa Air
- Kontrol Multikecepatan Kipas: Kipas CPU, Sasis, Pompa Air
- Pemantauan tegangan: +12V, +5V, +3,3V, CPU Vcore, CPU VDDCR\_SOC, DRAM, VPPM, +1,8V

**OS**

- Microsoft® Windows® 10 64-bit

**Sertifikasi**

- FCC, CE
- Mendukung ErP/EuP (memerlukan catu daya untuk ErP/EuP)

\* Untuk informasi rinci tentang produk, kunjungi situs web kami: <http://www.asrock.com>



Perlu diketahui, overclocking memiliki risiko tertentu, termasuk menyesuaikan pengaturan pada BIOS, menerapkan Teknologi Untied Overclocking, atau menggunakan alat bantu overclocking pihak ketiga. Overclocking dapat mempengaruhi stabilitas sistem, atau bahkan mengakibatkan kerusakan komponen dan perangkat sistem. Risiko dan biaya apa pun menjadi tanggungan Anda. Kami tidak bertanggung jawab atas kemungkinan kerusakan karena overclocking.

## **Contact Information**

If you need to contact ASRock or want to know more about ASRock, you're welcome to visit ASRock's website at <http://www.asrock.com>; or you may contact your dealer for further information. For technical questions, please submit a support request form at <https://event.asrock.com/tsd.asp>

### **ASRock Incorporation**

2F., No.37, Sec. 2, Jhongyang S. Rd., Beitou District,

Taipei City 112, Taiwan (R.O.C.)

### **ASRock EUROPE B.V.**

Bijsterhuizen 11-11

6546 AR Nijmegen

The Netherlands

Phone: +31-24-345-44-33

Fax: +31-24-345-44-38

### **ASRock America, Inc.**

13848 Magnolia Ave, Chino, CA91710

U.S.A.

Phone: +1-909-590-8308

Fax: +1-909-590-1026

# DECLARATION OF CONFORMITY

Per FCC Part 2 Section 2.1077(a)



**Responsible Party Name:** ASRock Incorporation

**Address:** 13848 Magnolia Ave, Chino, CA91710

**Phone/Fax No:** +1-909-590-8308/+1-909-590-1026

hereby declares that the product

**Product Name : Motherboard**

**Model Number : B550M Phantom Gaming 4**

Conforms to the following specifications:

FCC Part 15, Subpart B, Unintentional Radiators

## Supplementary Information:

This device complies with part 15 of the FCC Rules. Operation is subject to the following two conditions: (1) This device may not cause harmful interference, and (2) this device must accept any interference received, including interference that may cause undesired operation.

Representative Person's Name: James

Signature:

A handwritten signature in black ink, appearing to read 'James', written over a horizontal line.

Date : May 12, 2017

# EU Declaration of Conformity

# ASRock®

For the following equipment:

## Motherboard

(Product Name)

## B550M Phantom Gaming 4/ ASRock

(Model Designation / Trade Name)

## ASRock Incorporation

(Manufacturer Name)

2F, No.37, Sec. 2, Jhongyang S. Rd., Beitou District, Taipei City 112, Taiwan (R.O.C.)

(Manufacturer Address)

**EMC — Directive 2014/30/EU (from April 20th, 2016)**

EN 55022:2010/AC:2011 Class B

EN 55024:2010/A1:2015

EN 55032:2012+AC:2013 Class B

EN 61000-3-3:2013

EN 61000-3-2:2014

**LVD — Directive 2014/35/EU (from April 20th, 2016)**

EN 60950-1 : 2011+ A2: 2013

EN 60950-1 : 2006/A12: 2011

**RoHS — Directive 2011/65/EU**

**CE marking**

(EU conformity marking)



## ASRock EUROPE B.V.

(Company Name)

## Bijsterhuizen 1111 6546 AR Nijmegen The Netherlands

(Company Address)

Person responsible for making this declaration:

(Name, Surname)

**A.V.P**

(Position / Title)

**September 11, 2020**

(Date)

P/N: 15G062254000AK V1.0