

LZB + LZC01

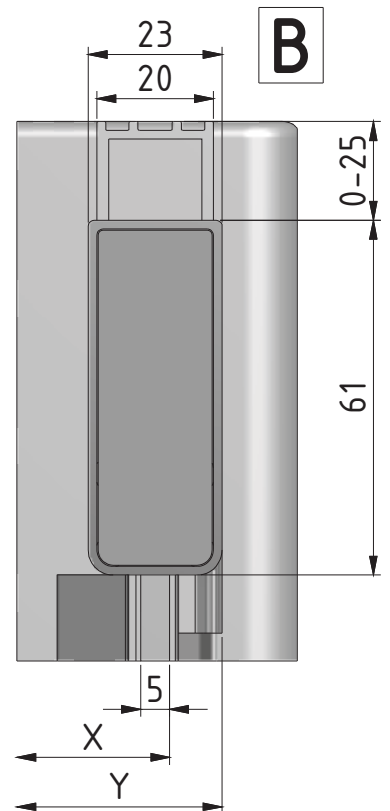
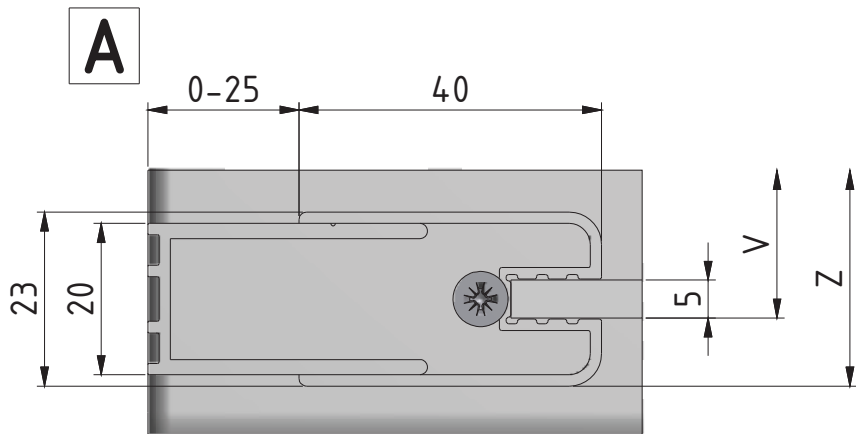
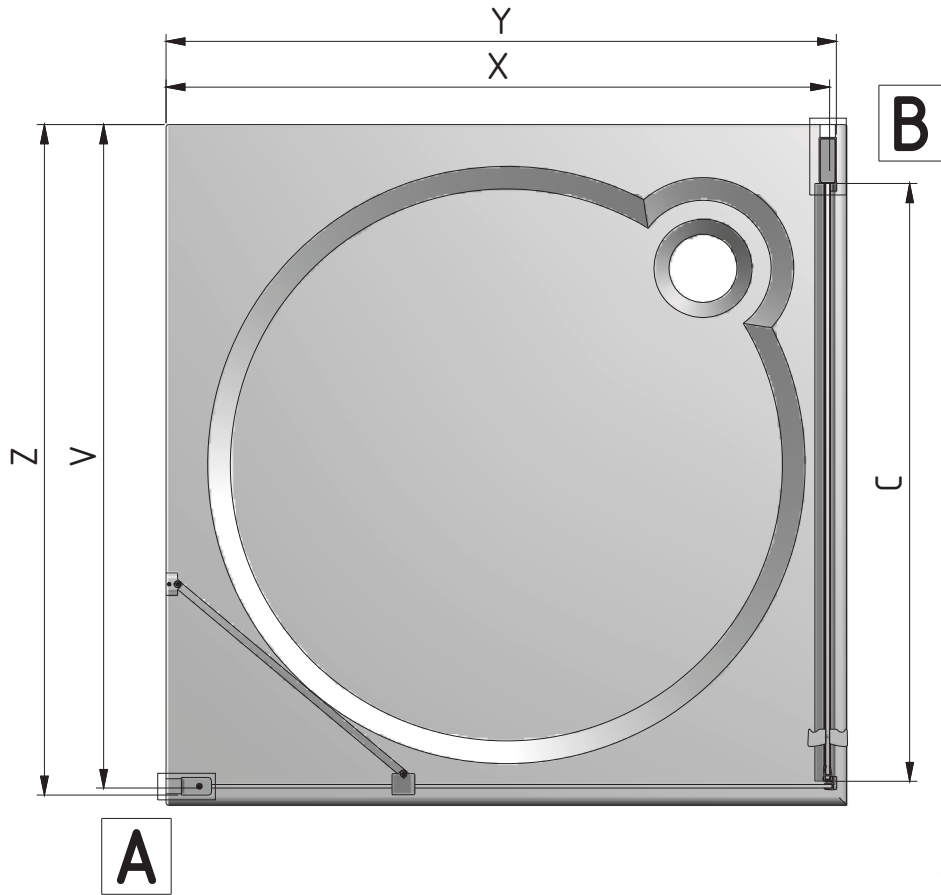

LZC01+LZB					
	X (MIN-MAX)	Y (MIN-MAX)	V (MIN-MAX)	Z (MIN-MAX)	C (mm)
800	758-783	767-792	761-786	770-795	690
900	858-883	867-892	861-886	870-895	790
1000	958-983	967-992	961-986	970-995	890