

PM3912WLD New product

classic

90cm "Classic" Mixed Fuel Hob with Gas Burner and Induction MultiZones, Straight Edge Glass

EAN13: 8017709235260

Left: 1 Ultra Rapid gas burner 6.00kW

- Cast iron pan stand
- Black Ceram burner coating
- Automatic electronic ignition
- Safety valves
- Adaptable for LPG

- 4 "full power" induction zones:
 - Front Centre: Ø 180/230mm, 2.10kW – booster 3.60kW
 - Rear Centre: Ø 180/230mm, 2.10kW – booster 3.60kW

The two zones in the centre can be combined to create one Multizone: Ø 230/385mm, booster 3.60kW

- Front right: Ø 180/230mm, 2.10kW – booster 3.60kW
- Rear right: Ø 180/230mm, 2.10kW – booster 3.60kW

The two zones on the right can be combined to create one Multizone: Ø 230/385mm, booster 3.60kW

- Black ceramic glass
- 9 power levels
- 4 boosters
- Slider touch controls
- Residual time indicator
- Quick level selection
- Simmering function
- Melting/low temp function
- Keep warm automatic function
- Pause option
- Automatic pan recognition
- Overheating and overflow protection system
- Protection against accidental start up
- End of cooking acoustic alarm
- Automatic safety cut out
- Child safety lock

- NB: Only pans with a ferrous (magnetic) base are suitable for induction hobs

- Nominal power: 7.40 kW



Functions





Heavy duty cast iron pan stands:
for maximum stability and strength.



Multizone:

allows several pans to be used at once, large or small, offering freedom of placement and greater flexibility



Slider Control:

Easy to use Slider control allows the appliance to be set by rotating your finger on the pad using circular movements



PM3912WLD

classic

mixed fuel
90 cm
black
front controls
built-in

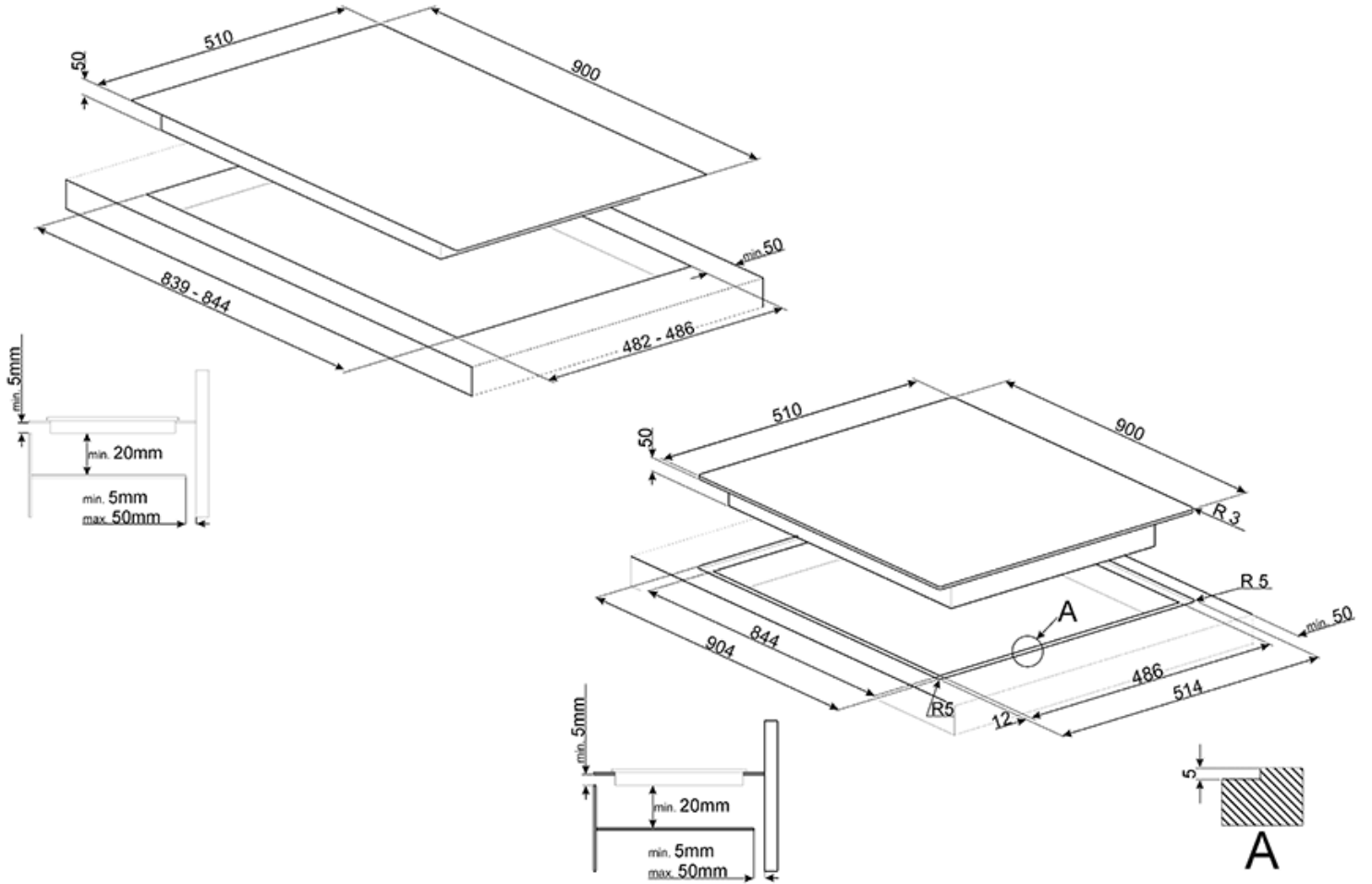

Smeg (UK) Ltd
The Magna Building, Wyndyke Furlong, Abingdon
OX14 1DZ
Tel. +44 (0)844 557 9907
Fax +44 (0)844 557 9337