

2010

Installation manual

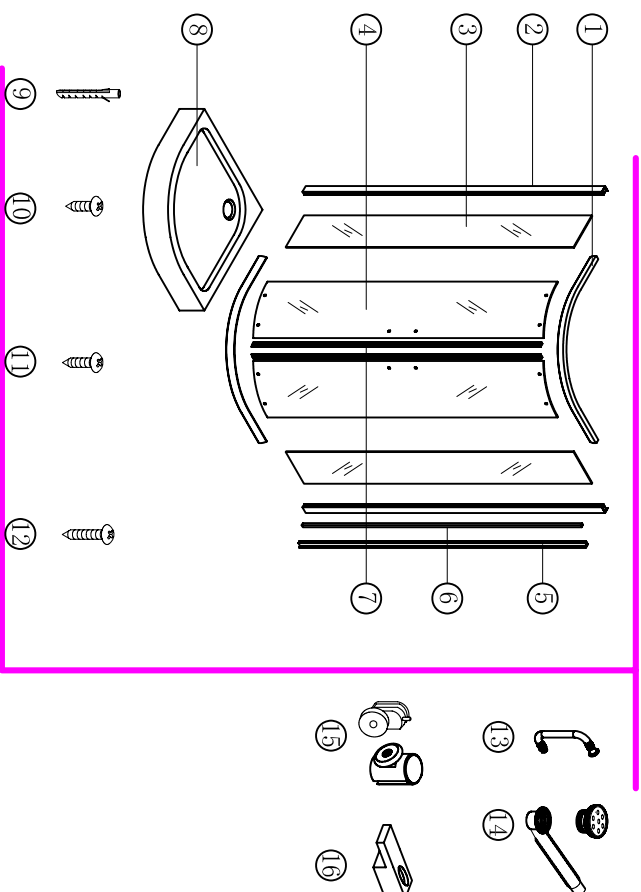
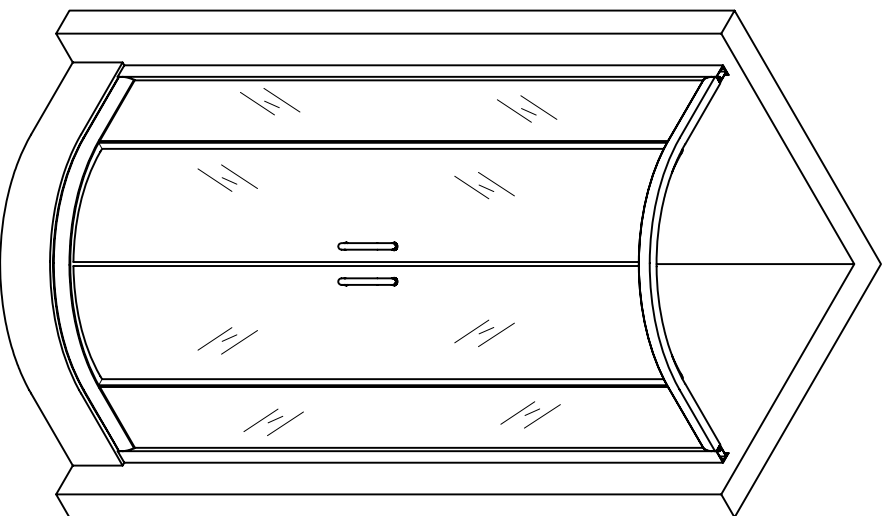

INSTALLATION ACCESSORIES LIST

NO.	NAME	QTY	UNIT	NO.	NAME	QTY	UNIT	NO.	NAME	QTY	UNIT
①		4		⑧		1		⑮		8	
②		2		⑨		6		⑯		4	
③		2		⑩	ST4*14	8		⑰			
④		2		⑪	ST4*16	4		⑱			
⑤		4		⑫	ST4*35	6					
⑥		4		⑬		2					
⑦		1		⑭		1					

Tools for installation

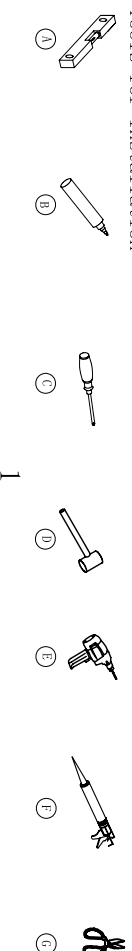

step 1 :

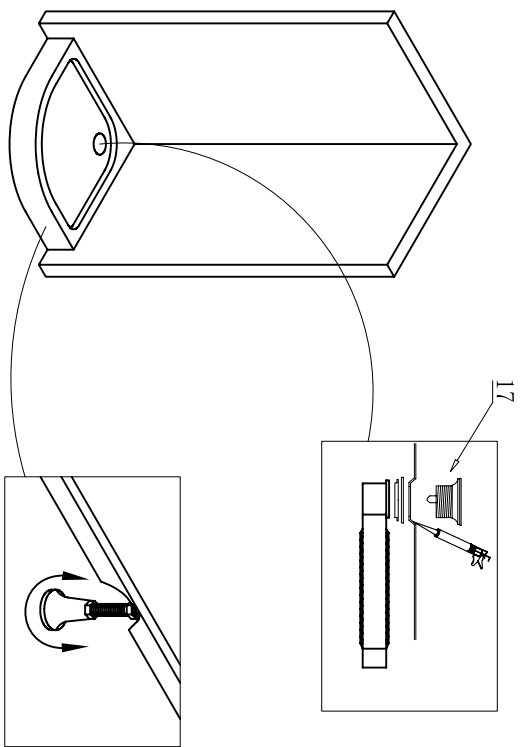

step3 :

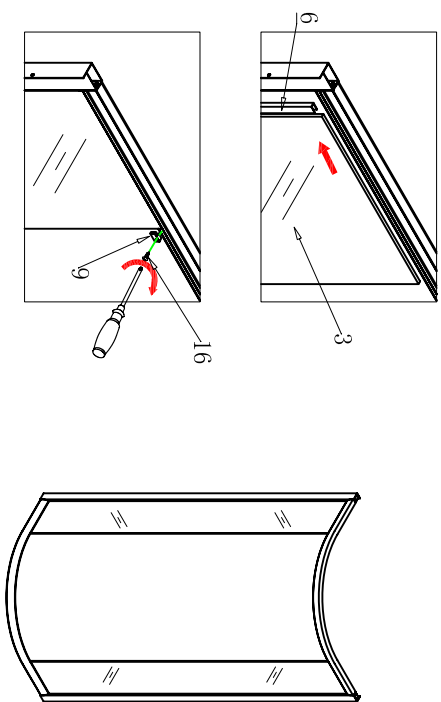

step2:

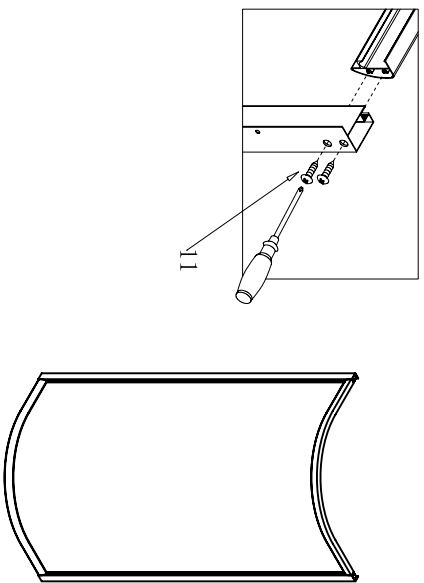

step4:

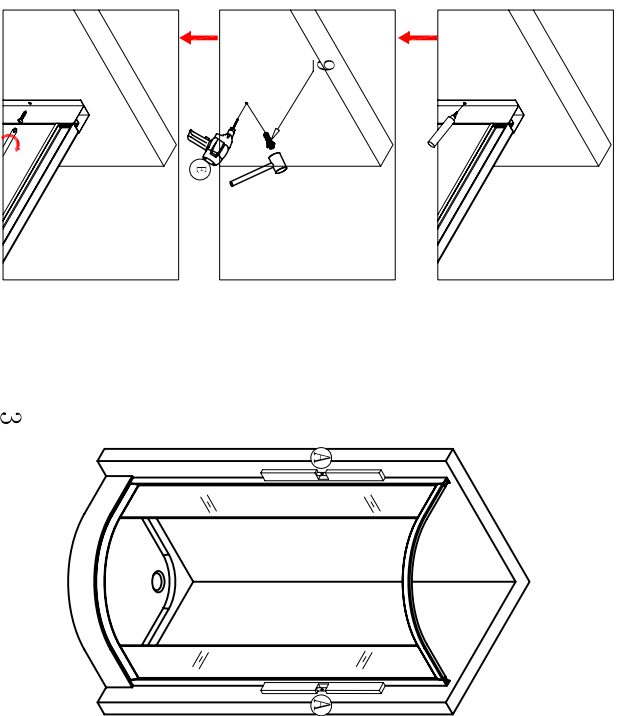

2

3

step5 :

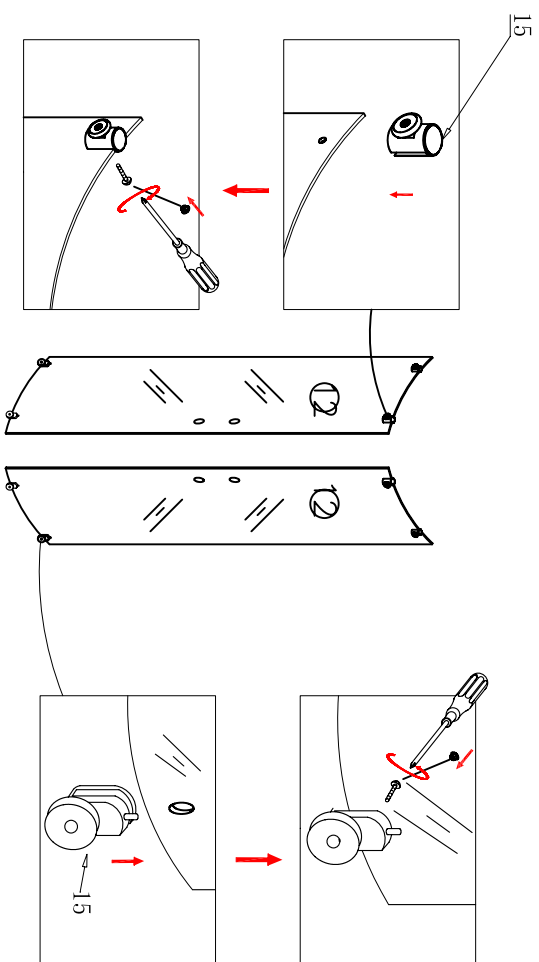

step7 :

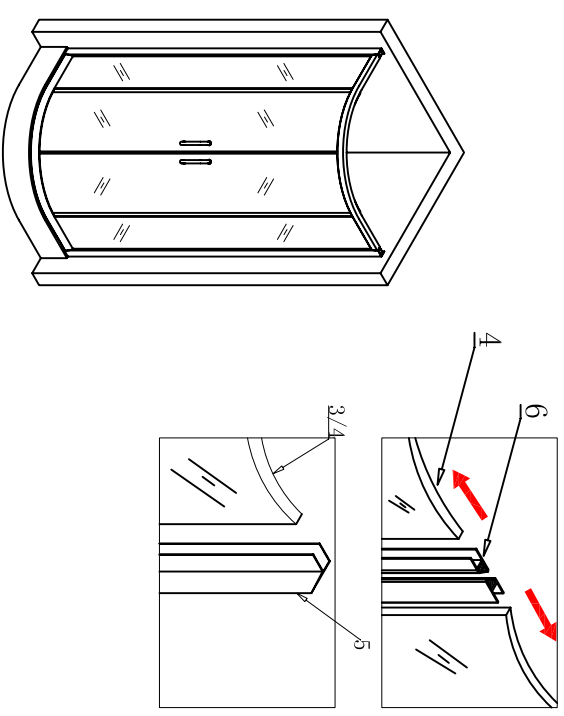

step6 :

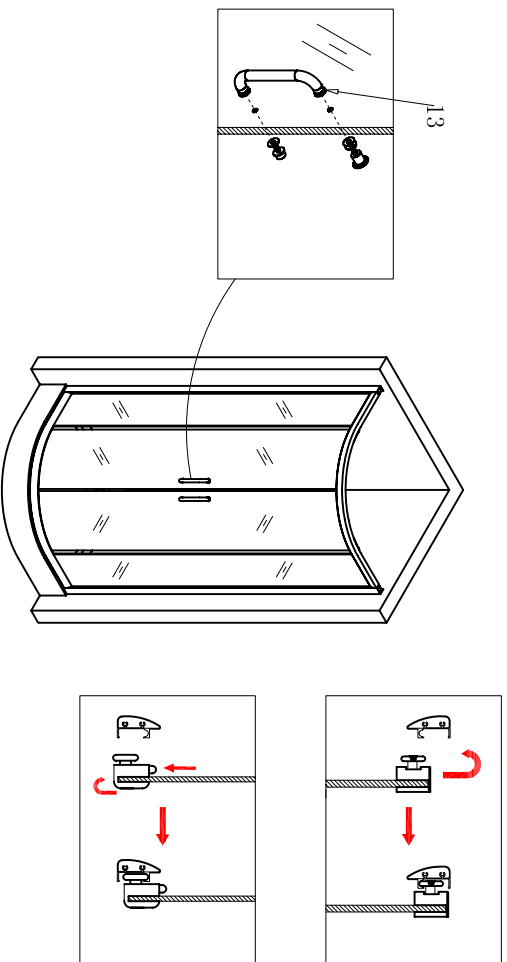

step8 :

