

# Application Guide

# Table of Contents

OVERVIEW .....	01
SYSTEM ELEMENTS .....	02
COMPLEMENTARY PRODUCTS .....	04
SYSTEM ACCESSORIES .....	06
APPLICATION EXAMPLES .....	09
CONNECTION DIAGRAMS .....	13
SERIES SPECIFICATIONS .....	17





QSC'S E SERIES ENTERTAINMENT SYSTEMS ARE DESIGNED FOR SOUND REINFORCEMENT IN LIVE PERFORMANCE, DANCE MUSIC AND KARAOKE APPLICATIONS. A TOTAL SYSTEM CONSISTS OF HIGH-PERFORMANCE, COST-EFFECTIVE LOUDSPEAKERS AS WELL AS POWER AMPLIFIERS AND DIGITAL MIXERS WITH OPTIMIZED SIGNAL PROCESSING PRESETS FOR THE LOUDSPEAKERS. WHILE E SERIES LOUDSPEAKERS DELIVER EXCELLENT PERFORMANCE WITH ANY HIGH-QUALITY PROFESSIONAL POWER AMPLIFIER, THE REAL MAGIC HAPPENS WHEN THEY ARE PAIRED WITH THE FINELY TUNED DIGITAL SIGNAL PROCESSING (DSP) FOUND IN QSC'S PLD AND GXD SERIES AMPLIFIER AND IN TOUCHMIX™ DIGITAL MIXERS. THE SETTINGS QSC HAS DEVELOPED FOR THESE THREE PLATFORMS ALLOW FOR PERFORMANCE THAT RIVALS TODAY'S POWERED LOUDSPEAKERS. THESE SETTINGS SUPPORT A VARIETY OF APPLICATIONS INCLUDING LIVE SOUND REINFORCEMENT (WITH AND WITHOUT SUBWOOFERS), STAGE MONITORING, DANCE MUSIC AND KARAOKE.

THIS IS THE E SERIES ENTERTAINMENT SYSTEM.

# SYSTEM ELEMENTS

## E SERIES LOUDSPEAKERS

### E10

The E10 is a compact 8 Ω two-way loudspeaker with a 10-inch, die cast frame woofer with a 2.5-inch voice coil housed in a multi-purpose enclosure that's at home in stage monitor or main PA deployment. It incorporates QSC's DMT™ (Directivity Matched Transition) design with a wide 85° coverage. When used as a stage monitor, the E10 angles up at a 55° angle, allowing it to be placed near the performer when used on a crowded stage.

- High output, professional quality sound with 300-watt continuous power rating
- E Series Entertainment System — Advanced digital signal processing tunings and options using QSC GXD or PLD Series amplifiers or TouchMix™ digital mixers
- Rugged tour-grade textured paint
- Foam-lined perforated steel grill
- Suitable as both a main PA and a stage monitor
- U-style yoke and M8 rigging kit available for permanent installation
- Dual-angle pole socket



Horizontal for monitor wedge use  
or vertical for mains

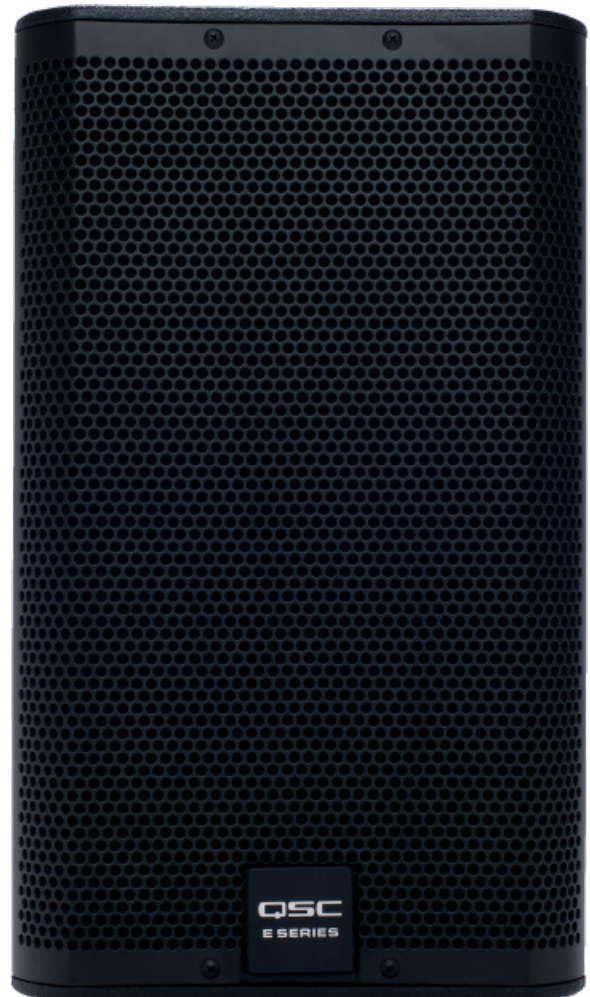



### E12

The E12 is a trapezoidal 8 Ω two-way loudspeaker using a 12-inch die cast aluminum woofer with a 3-inch voice coil. The 15 mm, 11-ply enclosure provides enough volume to deliver solid low-frequency extension down to 65 Hz, making it an excellent choice for applications in which space or budget preclude the use of a subwoofer. The DMT™ coverage angle of 85° is ideal for most medium and medium-long throw applications.

- High output, professional quality sound with a 400-watt continuous power rating
- E Series Entertainment System — Advanced digital signal processing tunings and options using QSC GXD or PLD Series amplifiers or TouchMix™ digital mixers
- Rugged tour-grade textured paint
- Foam-lined perforated steel grill
- U-style yoke and M8 rigging kit available for permanent installation
- Dual-angle pole socket

### E15

The E15 is a trapezoidal 8 Ω two-way loudspeaker using a 15-inch, 500-watt, die cast aluminum frame woofer with a 3.5-inch voice coil. It is intended for use when high power and authoritative low end are needed from a full-range loudspeaker. A 2.8" compression driver attached to the 75° DMT™ waveguide assures that even distant listeners will be well covered.

- High output, professional quality sound with 400-watt continuous power rating
- E Series Entertainment System — Advanced digital signal processing tunings and options using QSC GXD or PLD Series amplifiers or TouchMix™ digital mixers
- Rugged tour-grade textured paint
- Foam-lined perforated steel grill
- U-style yoke and M8 rigging kit available for permanent installation
- Dual-angle pole socket



### E18sw

The E18sw is a 4 Ω high-performance direct radiating subwoofer with a single 800-watt 18-inch aluminum frame woofer. It's designed to produce crushing low end for live performance with kick drum and bass in the PA or for high-level, high-energy dance music. A threaded M20 pole socket is provided for sub/satellite use with any of the E Series two-way models. For portable applications, it includes attachment points for four optional casters. The subwoofer's 4-ohm impedance means that a single subwoofer may be optimally powered by a less expensive amplifier.

- High output, professional quality sound with 800-watt continuous power rating
- E Series Entertainment System—Advanced digital signal processing tunings and options using QSC GXD or PLD amplifiers or TouchMix™ digital mixers
- Rugged tour-grade textured paint
- Foam-lined perforated steel grill
- Dual parallel NL4 connectors
- Includes threaded speaker pole

# COMPLEMENTARY PRODUCTS

## AMPLIFIERS/MIXERS



### GXD Series Amplifiers

The GXD Series features two 2-channel models with built-in E Series processing settings available. Older GXD amplifiers will be able to be made current by updating their [firmware](#) through the USB port on the rear panel. The GXD Series amplifiers are ideal for applications that use only a stereo pair of loudspeakers with no subs.

### PLD Series Amplifiers

With a range of 4-channel models, the PLD Series are the go-to amplifiers for systems that include subwoofers or multiple channels of loudspeakers and stage monitors.



### TouchMix™ Compact Digital Mixers

Processing presets for optimizing E Series performance are also available in QSC TouchMix™ digital mixers. Older TouchMix™ mixers can be made current by updating their [firmware](#).



## Choosing an Amplifier

At QSC, choosing an amplifier capable of delivering 2× the loudspeaker’s continuous power rating is generally recommended. However, for applications in which the system is used at more moderate levels, an amplifier with less power can be perfectly acceptable. And for systems where lots of dynamic headroom is desired an amplifier with more power may be used but caution must be taken not to overpower the drivers.

Amplifier	8 Ω Power	4 Ω Power	E10 E10 300 W / 8 Ω	E12 E12 400 W / 8 Ω	E15 E15 500 W / 8 Ω	E18sw E18sw 800 W / 4 Ω
<b>GXD4</b>	400 W	800 W	*	*	*	*
<b>GXD8</b>	800 W	1200 W	**	**	**	**
<b>PLD4.2</b> (4 channels)	500 W	700 W	**	*	*	*
<b>PLD4.3</b> (4 channels)	900 W	1400 W	***	**	**	**
<b>PLD4.5</b> (4 channels)	1200 W	2000 W	—	—	***	***

- \* An adequate, economical choice for moderate level uses.
- \*\* Good balance of cost and performance.
- \*\*\* Best for wide dynamic range and high levels, but may be slightly more power than needed.
- Not recommended.

# SYSTEM ACCESSORIES

KITS / MOUNTS / COVERS



## Dual-Angle Pole Socket

A loudspeaker on a stand is a common application for portable and temporary sound systems. All too often though, the loudspeaker axis points over the heads of the audience and puts acoustic energy on the back wall — something that can compromise sound quality. To solve this problem, the E10, E12 and E15 have dual pole sockets that allow the loudspeaker cabinet to sit upright on a stand or tilt downward at a 10-degree angle to better cover an audience.

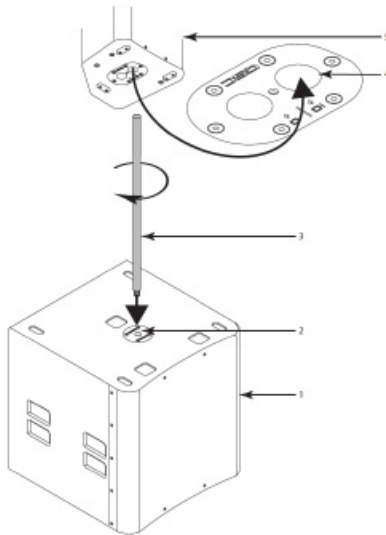

## Threaded Pole

The 24-inch (610 mm) 35 mm diameter pole provided with the E18sw subwoofer threads into the M20 insert on the top of the subwoofer. The pole can support a single E10, E12, or E15 loudspeaker in either the straight or tilt-down position.

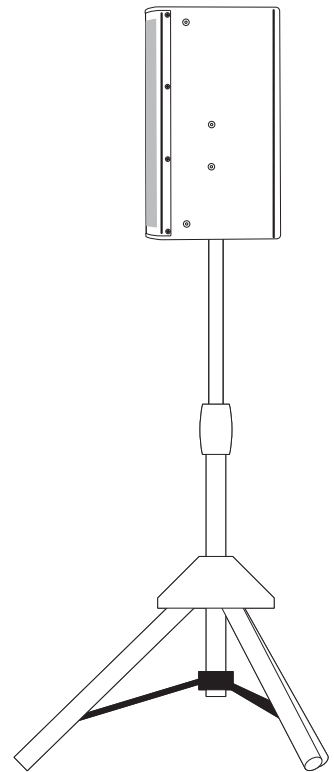

## Dual-angle pole socket:

0° top; 10° bottom.

The E10, E12 and E15 all have dual-angle pole socket.

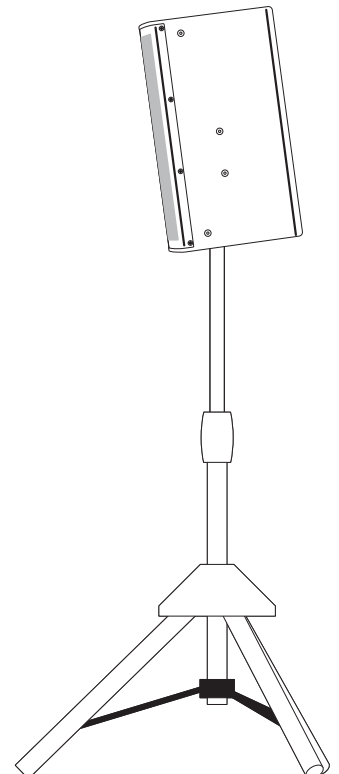



## M8 Eyebolt Kit

The E Series loudspeakers have M8 threaded attachment points for suspending or flying. QSC offers a kit of six M8 × 1.50 × 35–38 mm forged steel shoulder eye bolts. Shackles, cables etc. are not included. Consult a licensed rigger or structural engineer for designing flown loudspeaker systems.



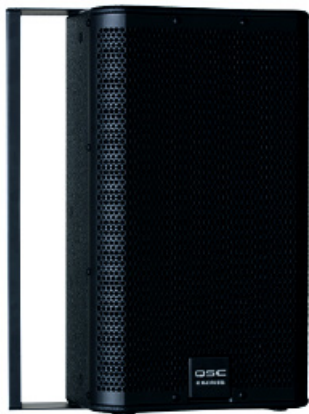

### Yoke Mount

QSC offers a yoke mount for each model except the subwoofer, which enables the loudspeaker to be attached to a ceiling, wall or other structural surface.

The model numbers are:

- E10 Yoke
- E12 Yoke
- E15 Yoke

### Subwoofer Caster Kit

For easier transport of the E18sw subwoofer, a kit of four 3-inch casters is available. The casters mount to the t-nuts that are factory installed on the rear of the subwoofer.

### Accessory Covers

Custom-fit padded covers protect your investment and keep your E Series loudspeakers looking new.

The model numbers are:

- E10 Cover
- E12 Cover
- E15 Cover
- E18 Cover

Please note that the E18 Cover is designed for use with E18sw subwoofers that have the optional Subwoofer Caster Kit installed.

# APPLICATION EXAMPLES

## REAL-WORLD APPLICATIONS FOR PROS

### Small System for Live Performance

This small two-loudspeaker system is suitable for supporting a solo performer or a duo, or even a combo that is small enough to not require monitors, in a small club, coffeehouse, or similar-sized venue. It consists of two E10 loudspeakers on stands with power provided by a QSC GXD4 amplifier. A QSC TouchMix-8 digital mixer handles mixing and effects processing. Selecting the E10 loudspeaker profiles in the GXD4 amplifier provides optimal voicing and protection for the loudspeakers.

NOTE: In a system that uses both a TouchMix™ and a GXD or PLD Series amplifier, use only the loudspeaker tunings in the amplifier. In small venues the E10's ability to tilt downward lets the audience – not the far wall – be the sweet spot.

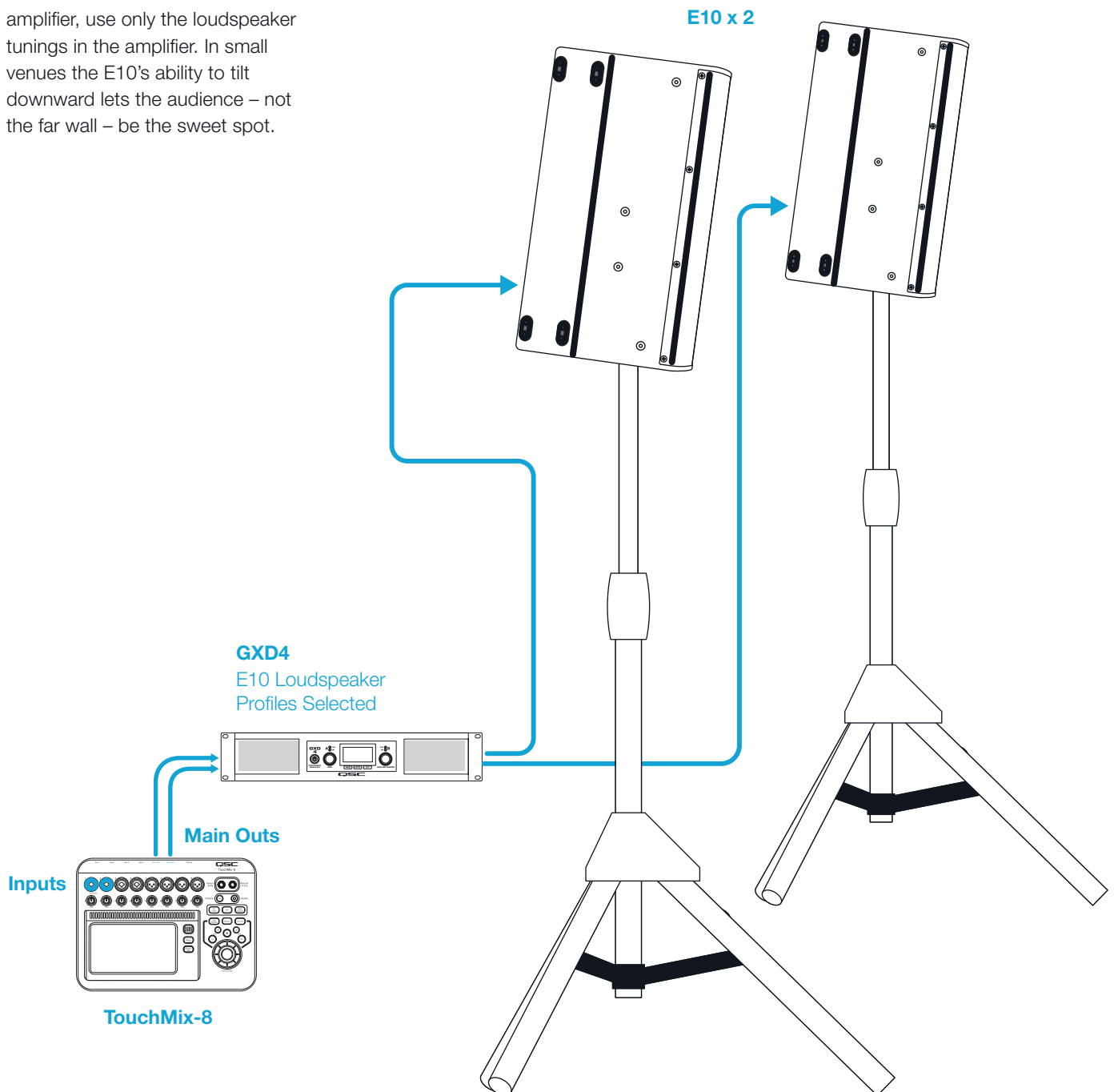

## Live System for Full Band

This system employs two E18sw subs with two E12 loudspeakers on top to be the mains. Four E10 boxes serve as wedge monitors. The monitors and the mains are powered by QSC PLD4.3 power amps. One of the amps handles the four individual monitor mixes, and the other drives the two subwoofers on paralleled channels A and B and the left and right main program on channels C and D, respectively.

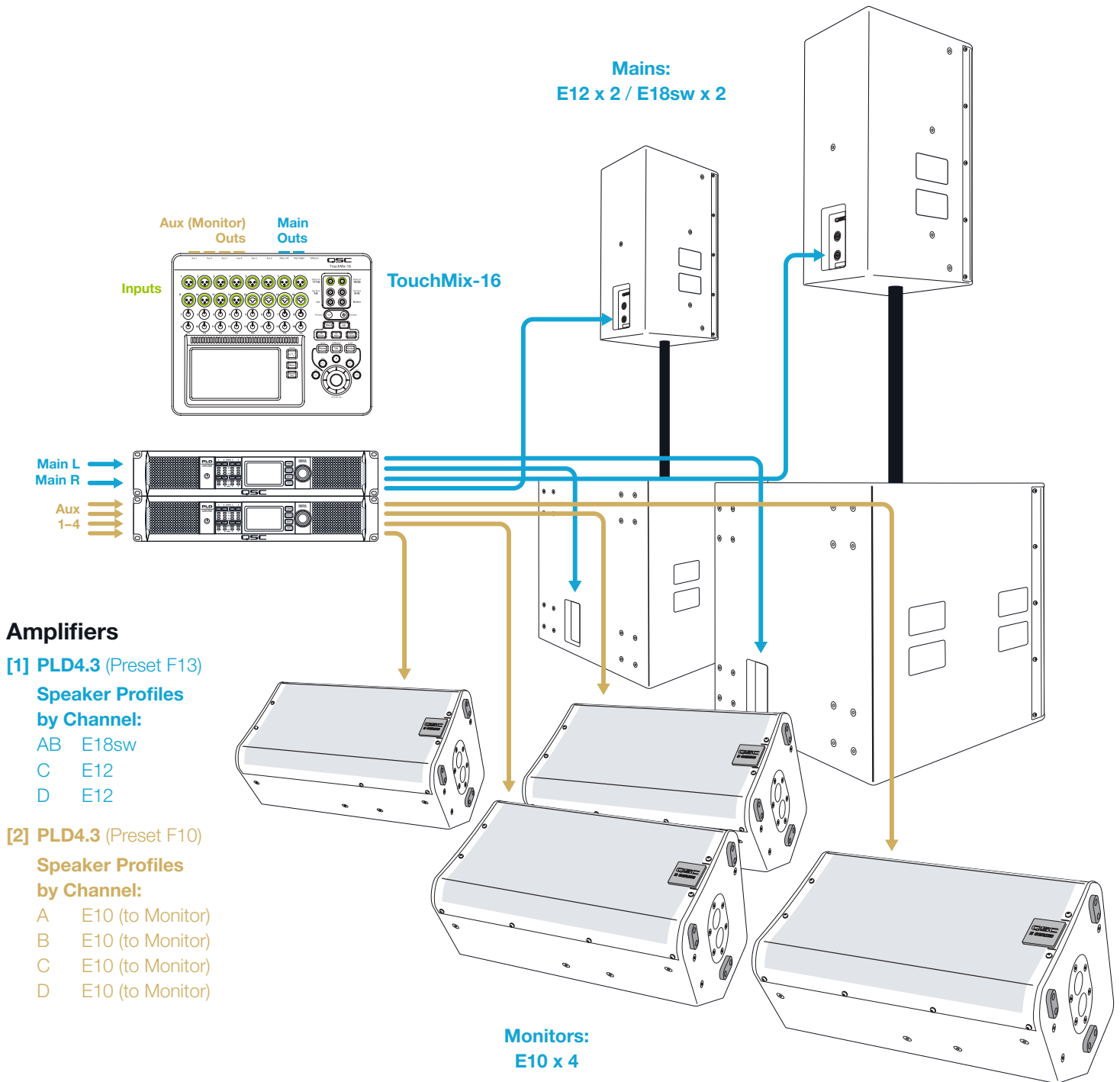

## Dance Club Rig

The system covers the dance floor with two flown E15 loudspeakers and two E18sw subwoofers on the floor. A PLD4.5 amplifier using the F13 preset and the E15 and E18sw profiles selected power the system. The DJ's mixer and mic feed a QSC TouchMix-8 digital mixer which provides the Main Right and Main Left signals to the power amplifier.

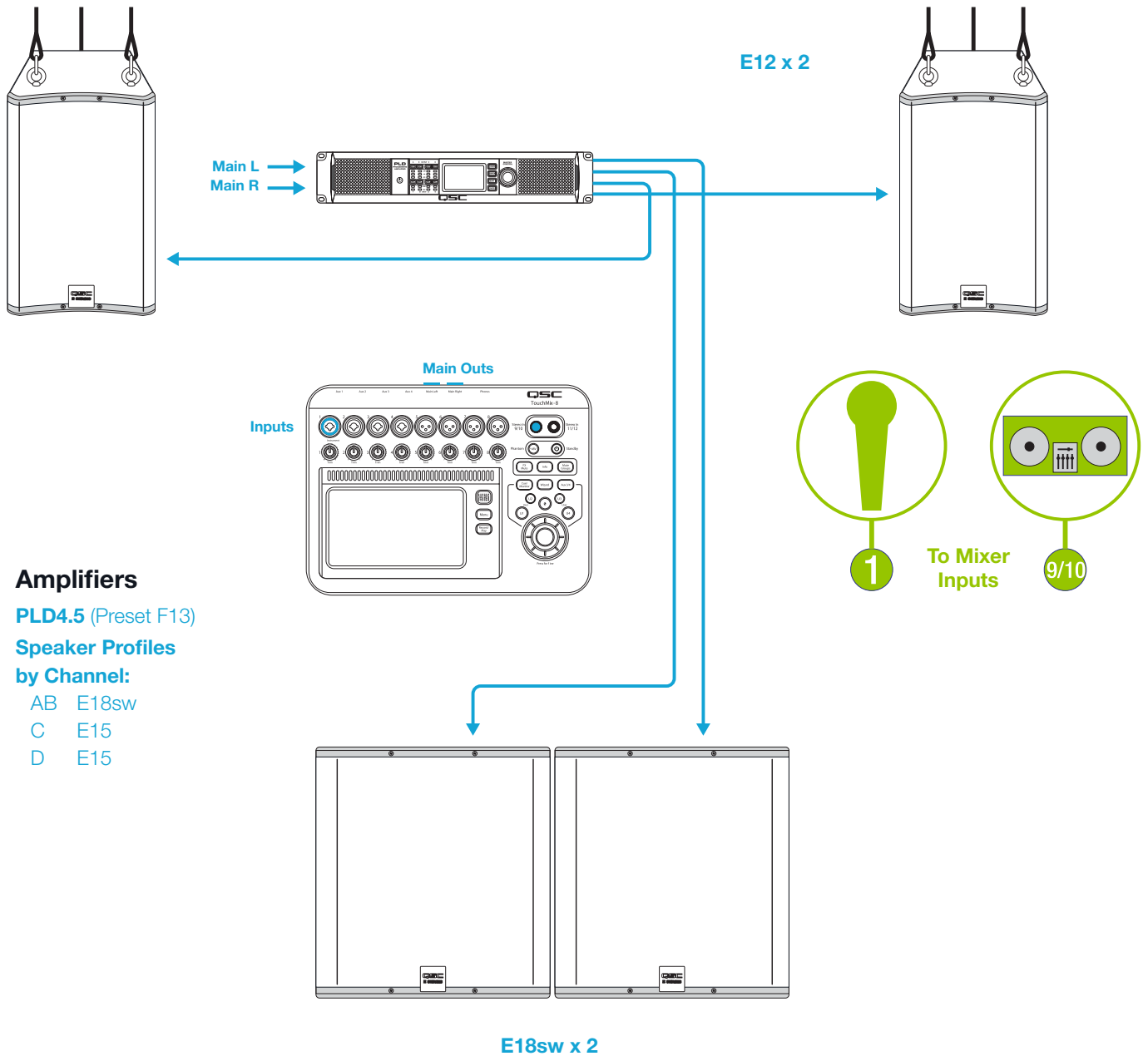

## Medium-Sized Live Performance System

Small band/combo gigs are a snap with two E12 boxes on stands and two E10's used as wedges. They're powered by a GXD8 amplifier on the mains and a GXD4 on the monitors, with the respective E12 and E10 profiles dialed in.

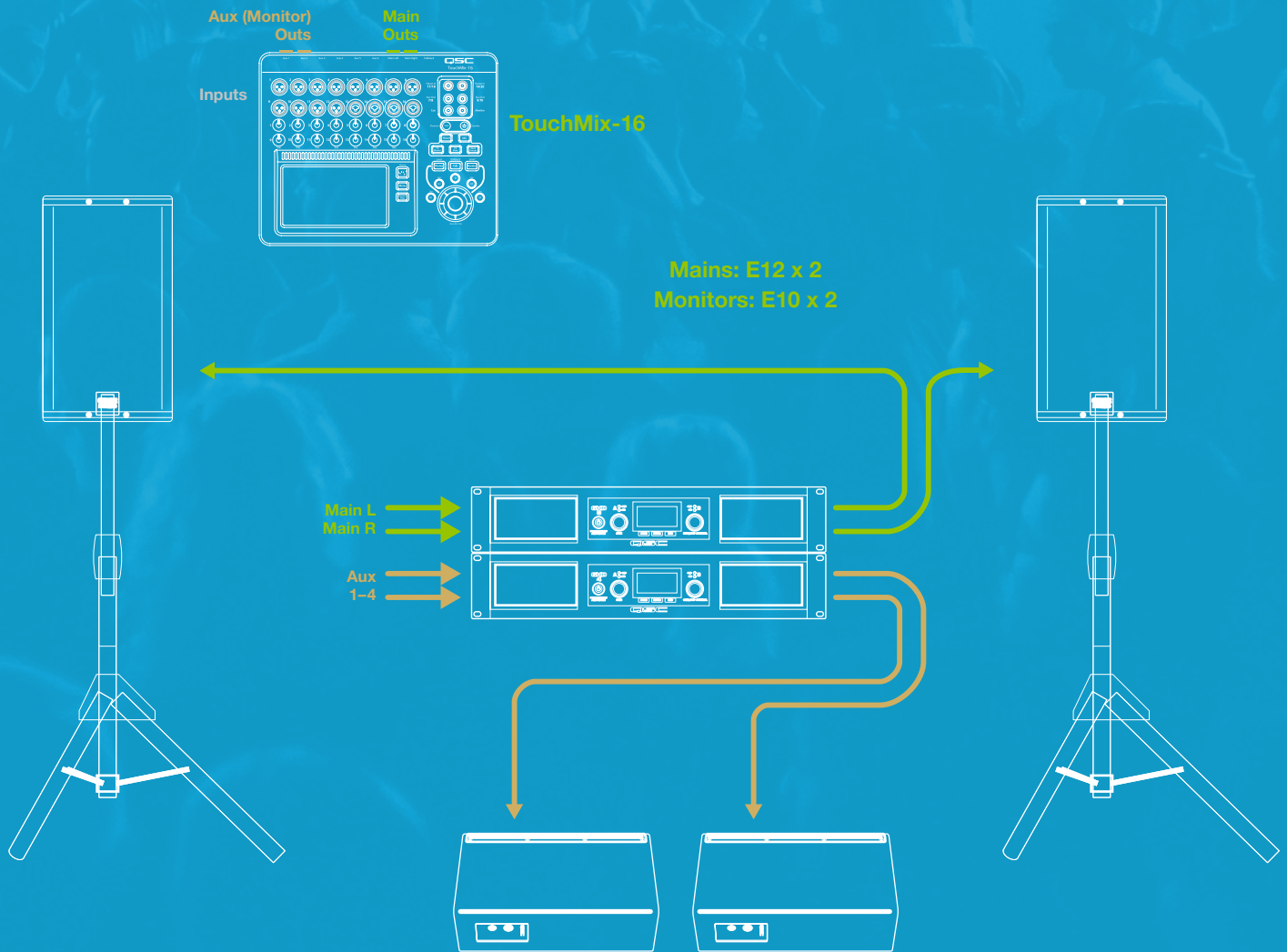

### Amplifiers

#### [1] GXD8

##### Speaker Profiles

##### by Channel:

- A E12
- B E12

#### [2] GXD4 (Preset F10)

##### Speaker Profiles

##### by Channel:

- A E10 (to Monitor)
- B E10 (to Monitor)

# CONNECTION DIAGRAMS

## E10, E12 AND E15 INPUT PANEL

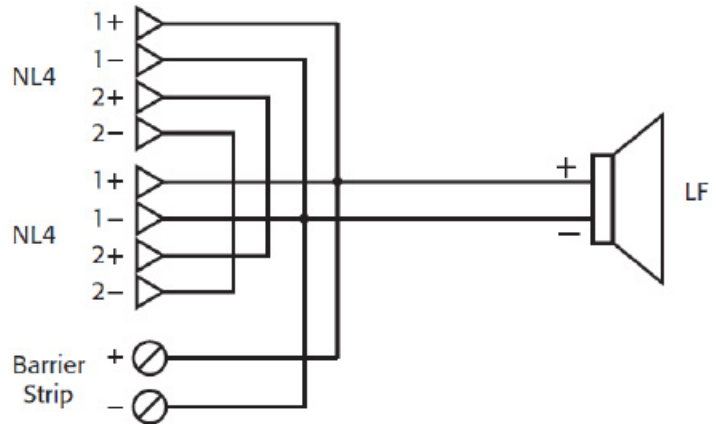
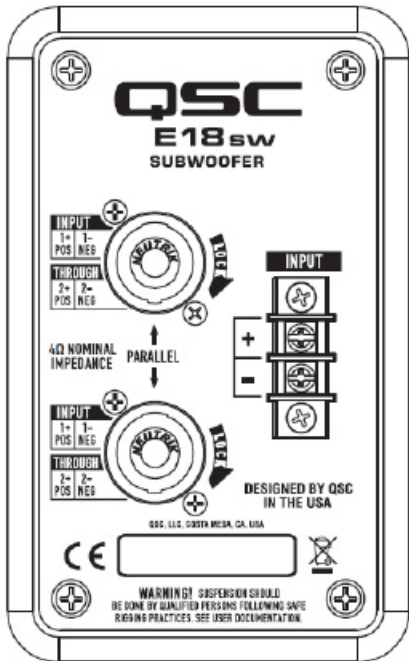
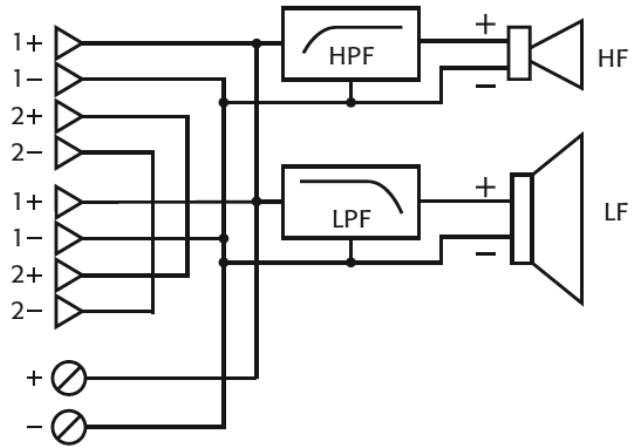
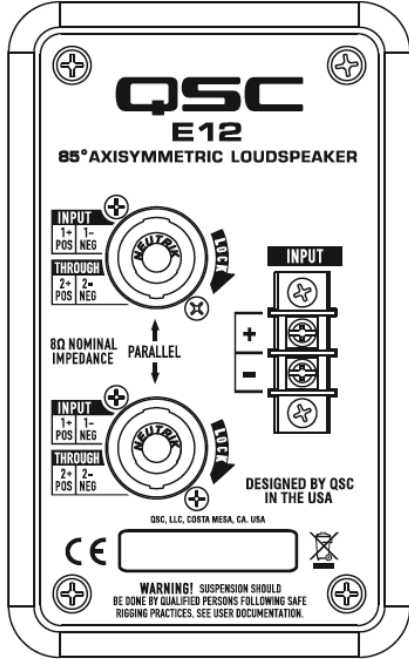

## Two Boxes with a 2-Channel Amplifier

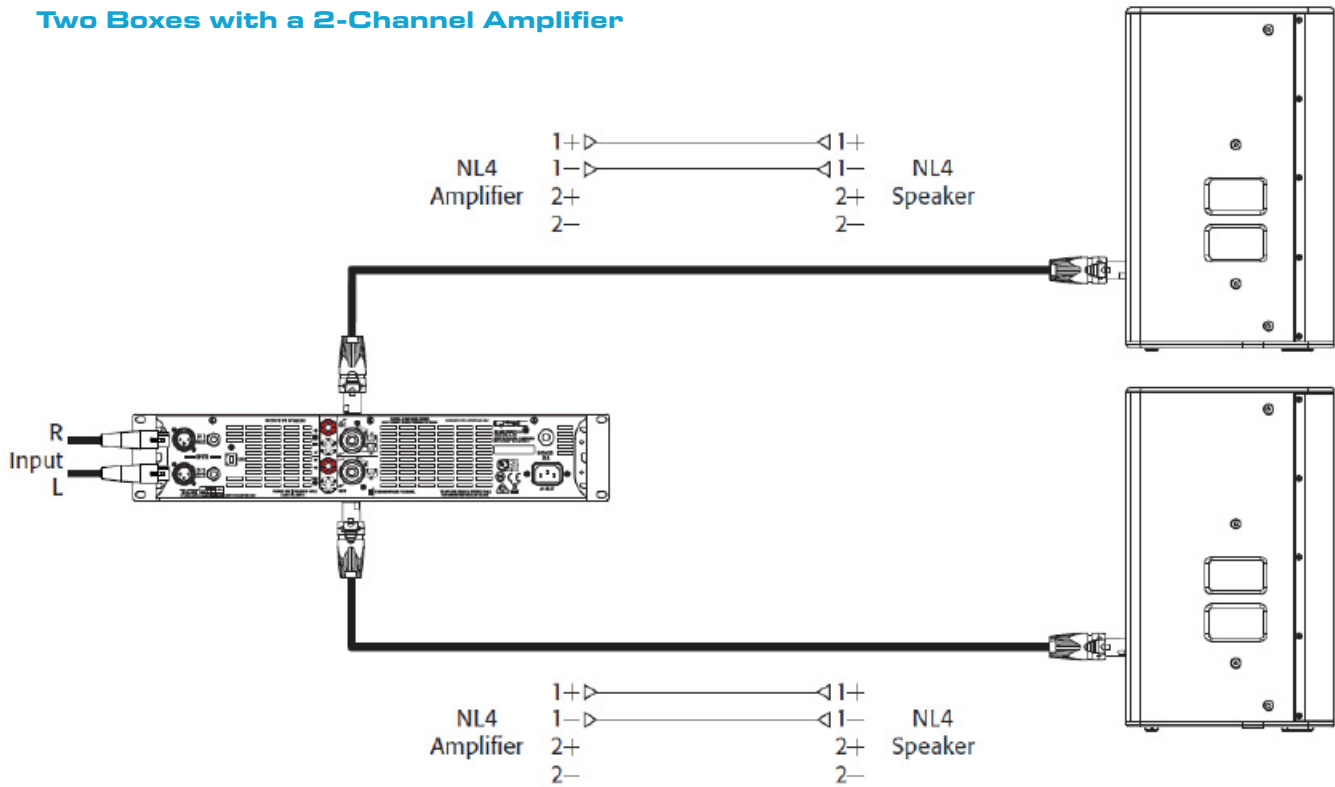

## Top and Sub on a 2-Channel Amplifier

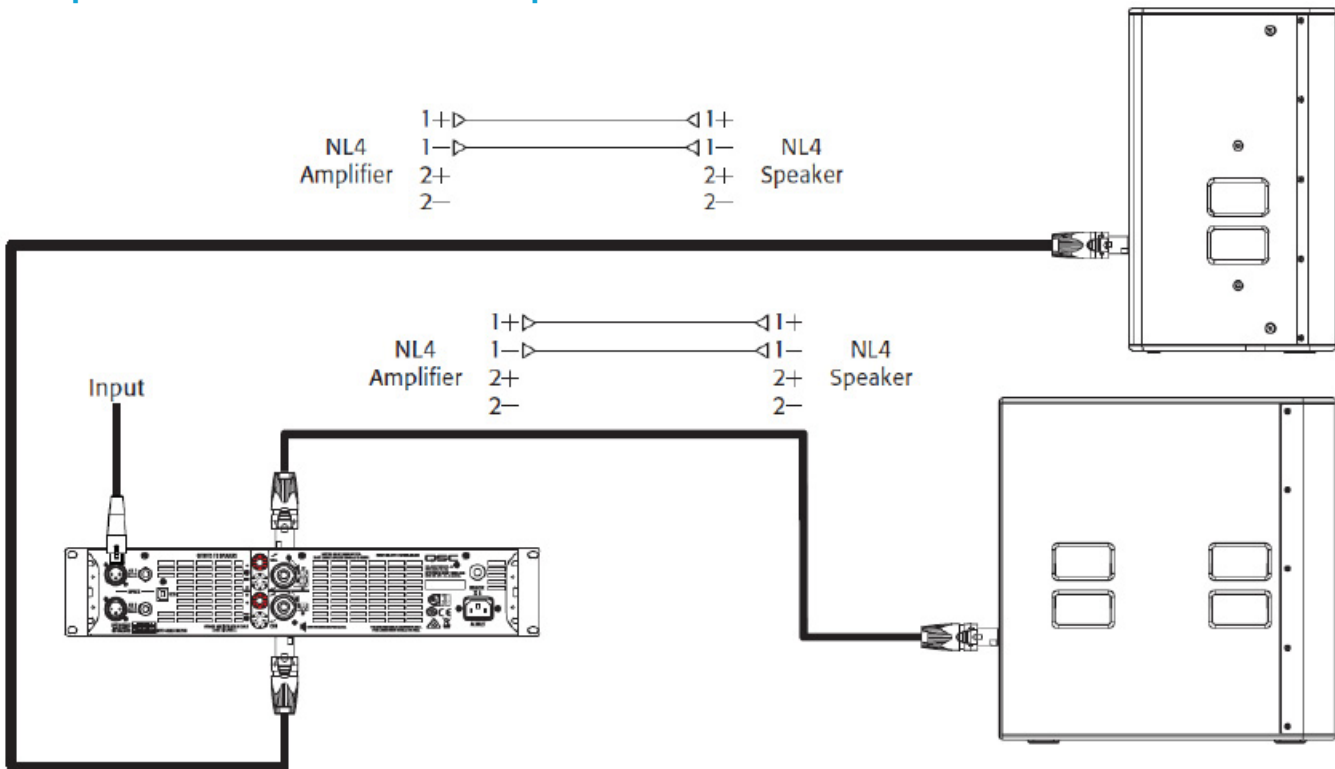



## Top and Sub on a 2-Channel Amplifier, Using a 4-Conductor Cable

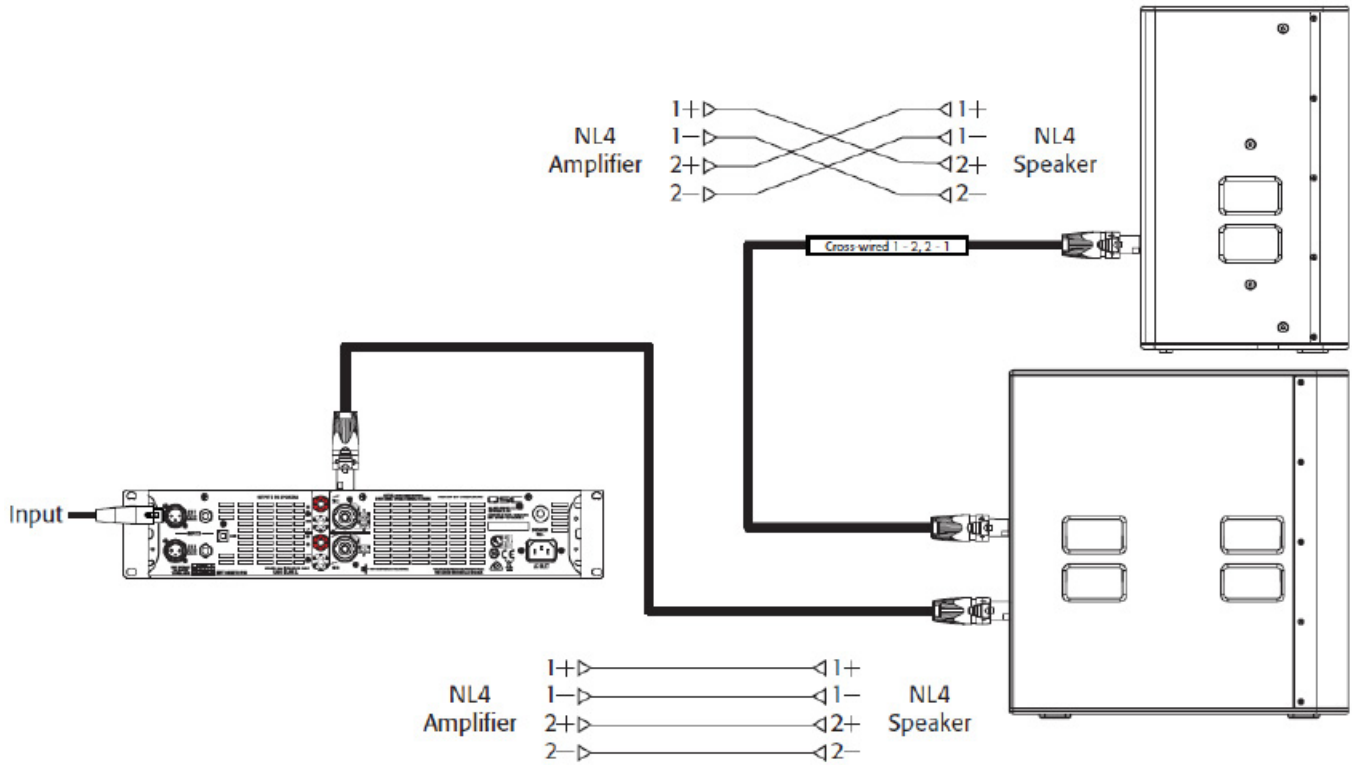

## Stereo Tops and Subs on two 2-Channel Amplifiers

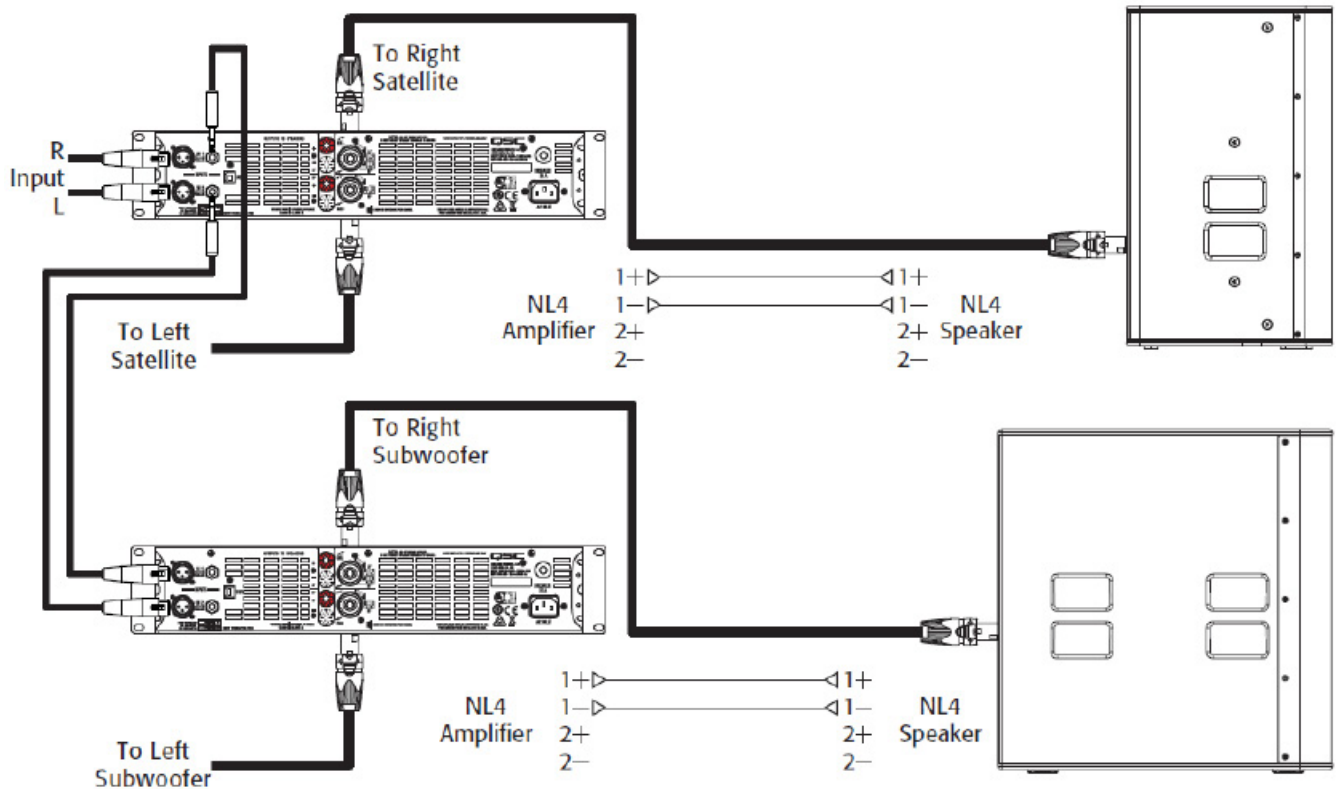

## Stereo Tops and Subs on a 4-Channel Amplifier

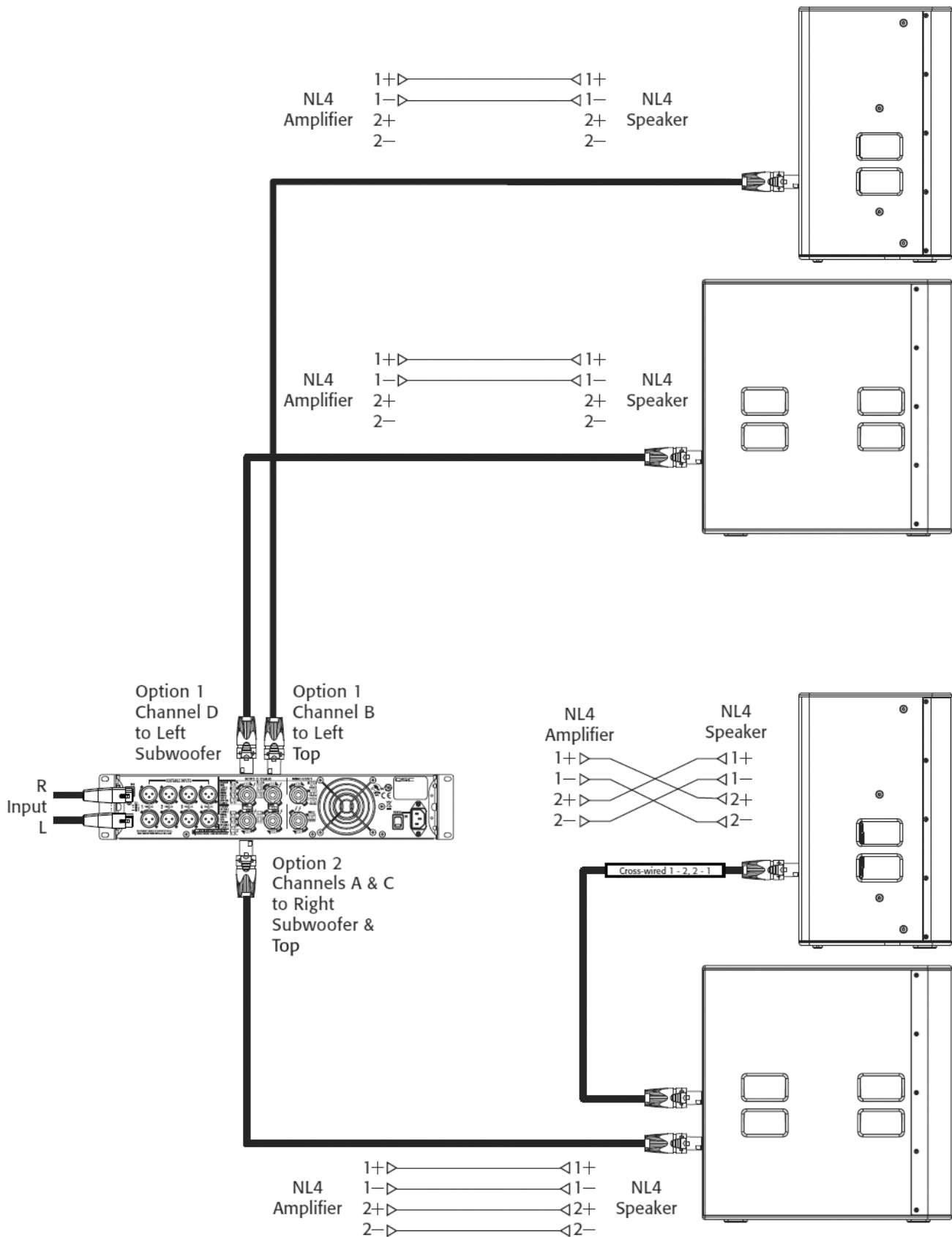

# SERIES SPECIFICATIONS

	<b>E10</b>	<b>E12</b>	<b>E15</b>
<b>Frequency response (+0 / -6 dB)</b>	68 Hz–20 kHz	64 Hz–20 kHz	55 Hz–20 kHz
<b>Frequency response with QSC Intrinsic Correction™ (+0 / -6 dB)</b>	60 Hz–20 kHz	52 Hz–20 kHz	47 Hz–20 kHz
<b>Low frequency response (-10 dB)</b>	50 Hz	50 Hz	43 Hz
<b>Low frequency response with QSC Intrinsic Correction™ (-10 dB)</b>	54 Hz	46 Hz	42 Hz
<b>Rated noise power/voltage</b>	300 W / 49 V rms	400 W / 57 V rms	500 W / 63 V rms
<b>Impedance</b>	8 Ω	8 Ω	8 Ω
<b>Crossover</b>	Passive 1.8 kHz	Passive 1.8 kHz	Passive 1.55 kHz
<b>Sensitivity @ 1 m</b>	95 dB (2.83 V rms)	96 dB (2.83 V rms)	97 dB (2.83 V rms)
<b>Coverage</b>	85° conical, DMT	85° conical, DMT	75° conical, DMT
<b>Peak SPL @ 1 m</b>	126 dB	128 dB	130 dB
<b>LF Driver</b>	254 mm (10 in) with 65 mm (2.5 in) voice coil	305 mm (12 in) with 76 mm (3 in) voice coil	381 mm (15 in) with 89 mm (3.5 in) voice coil
<b>HF driver</b>	Compression driver with 1 in exit, 45 mm (1.75 in) voice coil	Compression driver with 1 in exit, 45 mm (1.75 in) voice coil	Compression driver with 1.5 in exit, 76 mm (2.8 in) voice coil
<b>Input connectors</b>	Barrier strip, two NL4	Barrier strip, two NL4	Barrier strip, two NL4
<b>Enclosure</b>	Multi-angle plywood with black texture paint finish. One top mount handle. Perforated powder coated steel grille with foam lining.	Trapezoidal plywood with black texture paint finish. Two side mount handles. Perforated powder coated steel grille with foam lining.	Trapezoidal plywood with black texture paint finish. Two side mount handles. Perforated powder coated steel grille with foam lining.
<b>Mounting/suspension</b>	Six M8 suspension points. Dual-angle 35 mm pole socket.	Six M8 suspension points. Dual-angle 35 mm pole socket.	Six M8 suspension points. Dual-angle 35 mm pole socket.
<b>Net weight</b>	44 lb / 20 kg	51 lb / 23 kg	68 lb / 31 kg
<b>Shipping weight</b>	50 lb / 23 kg	57.5 lb / 26 kg	75 lb / 34 kg
<b>Dimensions (W × H × D)</b>	13 × 22 × 13 in 329 × 560 × 330 mm	14.2 × 24.2 × 14.6 in 360 × 616 × 371 mm	16.5 × 28.2 × 17.5 in 420 × 716 × 445 mm

	<b>E18sw</b>
<b>Frequency response (+0 / -6 dB)</b>	37–230 Hz
<b>Frequency response with QSC Intrinsic Correction™ (+0 / -6 dB)</b>	38–130 Hz
<b>Low frequency response (-10 dB)</b>	32 Hz
<b>Rated noise power/voltage</b>	800 W / 57 V rms
<b>Impedance</b>	4 Ω
<b>Crossover</b>	Recommend 80–120 Hz low-pass
<b>Sensitivity @ 1 m</b>	98 dB (2 V rms)
<b>Peak SPL @ 1 m</b>	133 dB
<b>LF Driver</b>	457 mm (18 in) with 102 mm (4 in) voice coil
<b>Input connectors</b>	Barrier strip, two NL4
<b>Enclosure</b>	Rectangular plywood with black texture paint finish. Four side mount handles. Rear panel attachment points for optional casters. Perforated powder coated steel grille with foam lining.
<b>Mounting/suspension</b>	M20 threaded pole mount socket 24-inch (610 mm) pole included
<b>Net weight</b>	95 lb / 43 kg
<b>Shipping weight</b>	106 lb / 48 kg
<b>Dimensions (W × H × D)</b>	23.2 × 24.2 × 23.8 in 590 × 616 × 605 mm



[www.qsc.com](http://www.qsc.com) | +1.800.854.4079 | +1.714.754.6175

QSC, LLC, 1675 MacArthur Boulevard Costa Mesa, CA 92626 USA. ©2016 QSC, LLC. All rights reserved. QSC and the the QSC logo are registered trademarks of QSC, LLC in the U.S. Patent and Trademark Office and other countries.

