

# E Series



## Quick Start Guide

### Input Configuration

E Series two-way loudspeakers and subwoofers are designed for externally powered operation. Pass-throughs permit connection to multiple loudspeakers. The two-way models feature internal passive crossovers for full-range operation. To use them with subwoofers, use an active crossover and separate amplification to split the subwoofer frequencies and the remainder of the audio spectrum.

PLD and GXD Series amplifiers have E Series voicings available in their presets and loudspeaker profiles. TouchMix digital mixers also have E Series voicings available, for use in systems that don't have PLD or GXD Series amplifiers.

### E Series E110, E12, E15, E215 Block Diagram and Input Plate

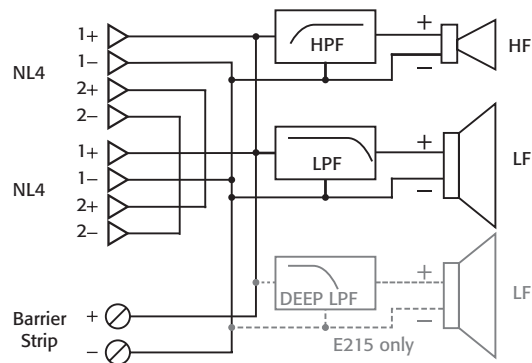
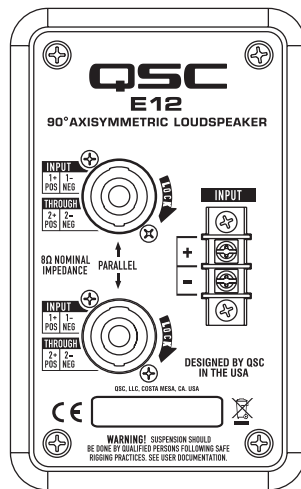

– Figure 1 –

### E Series E18sw, E218sw Block Diagram and Input Plate

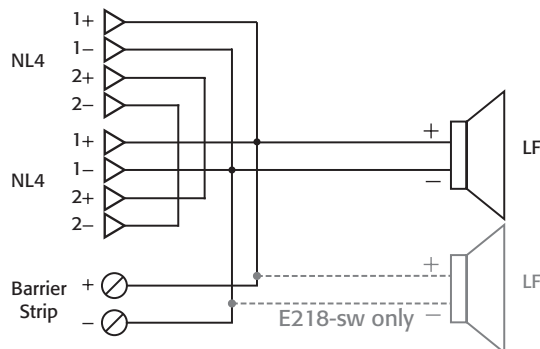
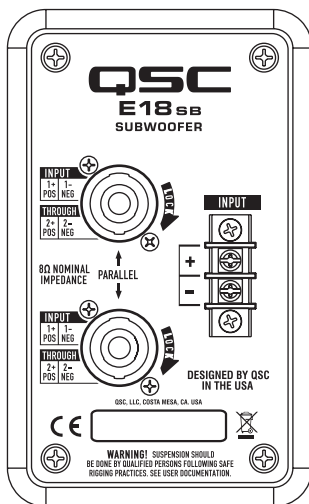

– Figure 2 –

TD-000525-00-D



# Connections

## Full Range Stereo System

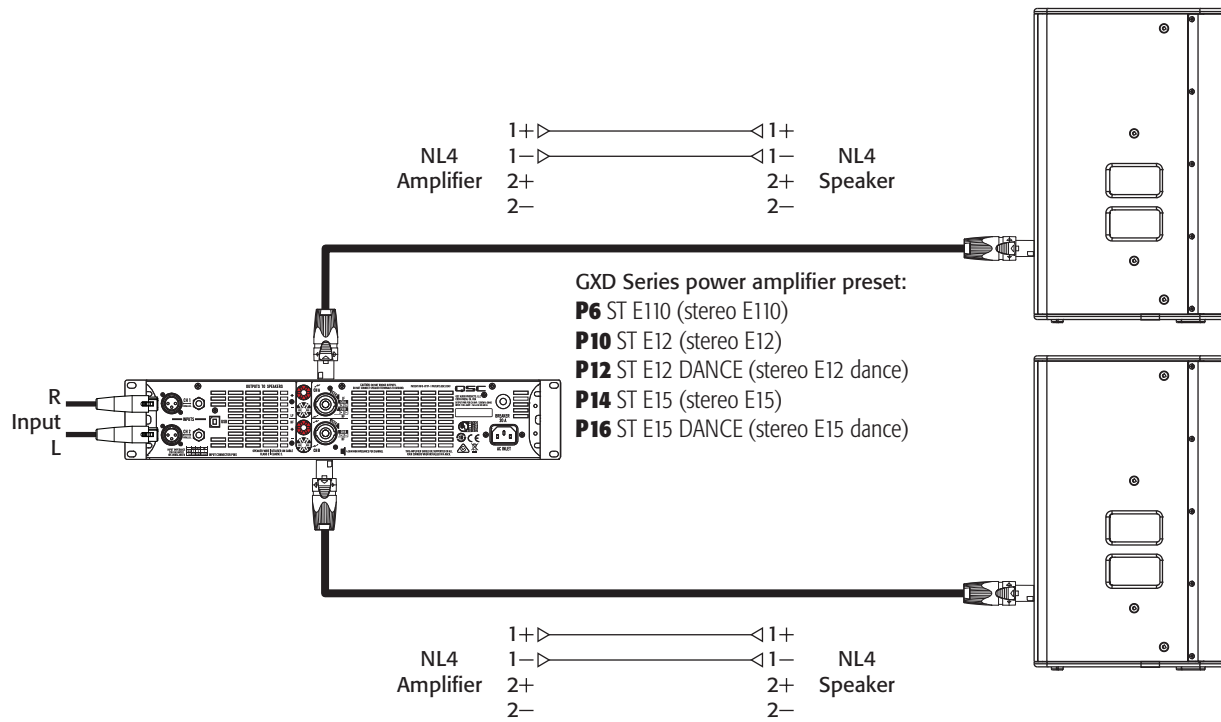

- Figure 3 -

## Single Channel, Sub / Satellite Option 1

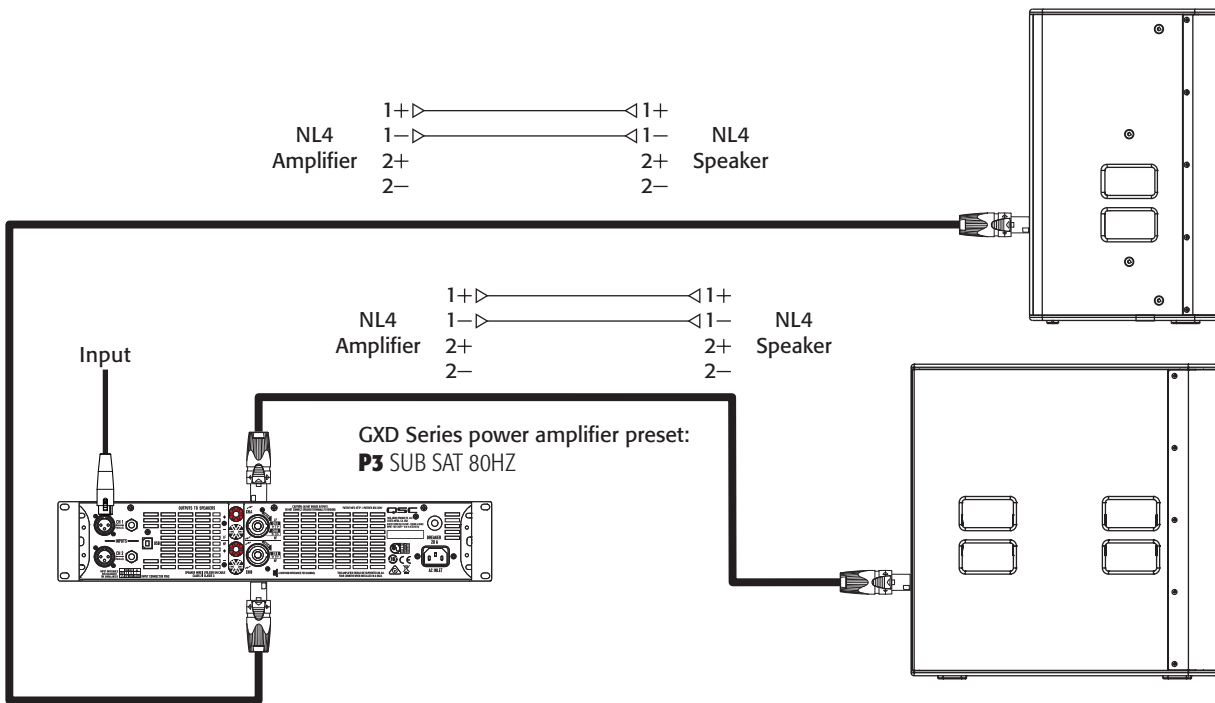

- Figure 4 -

## Single Channel, Sub / Satellite Option 2

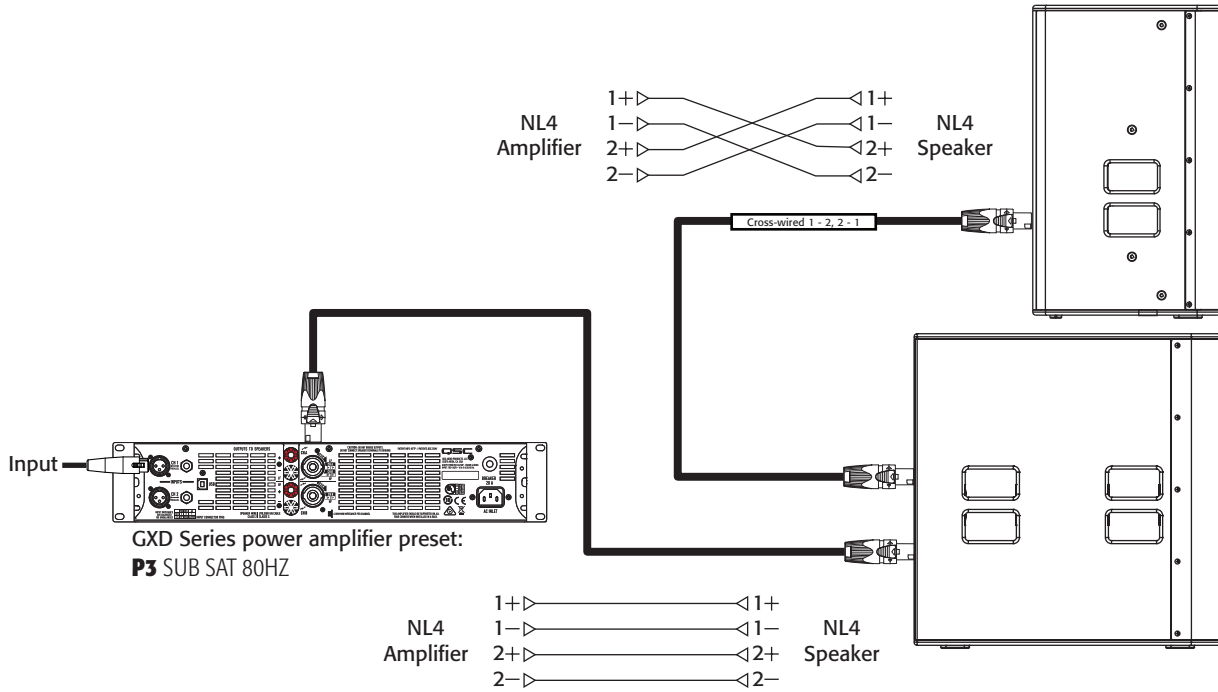

- Figure 5 -

## Dual Channel, Sub / Satellite System

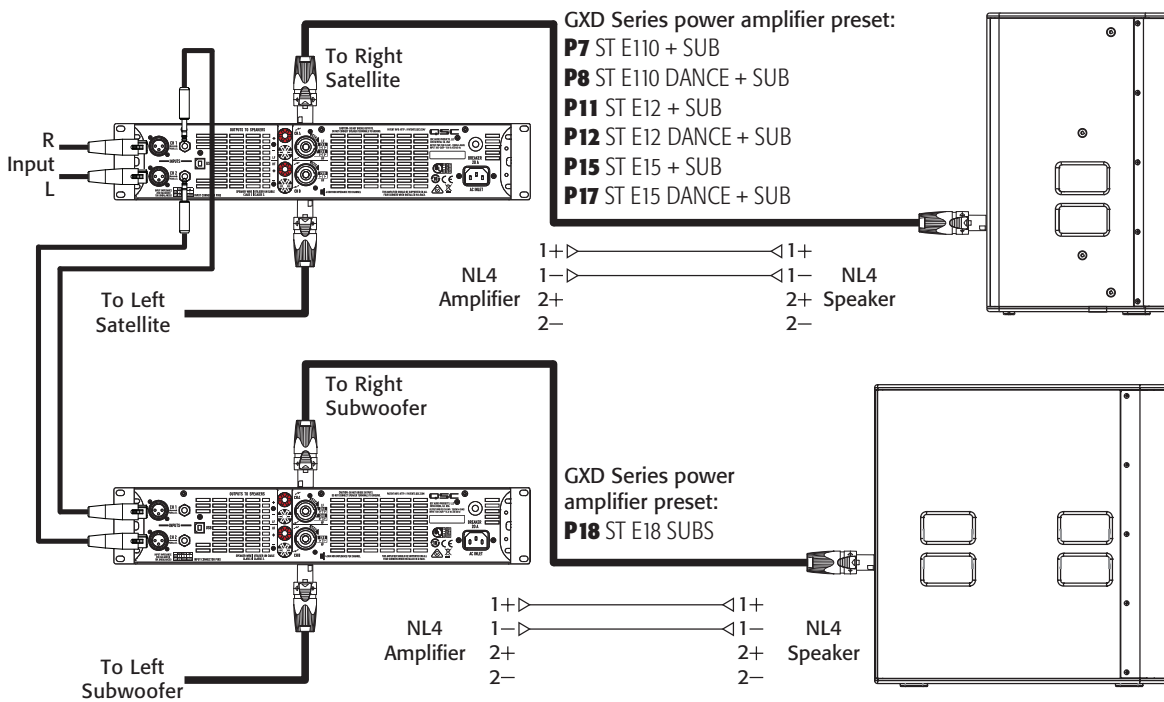

- Figure 6 -

# Dual Channel, Sub / Satellite System with 4-channel PLD

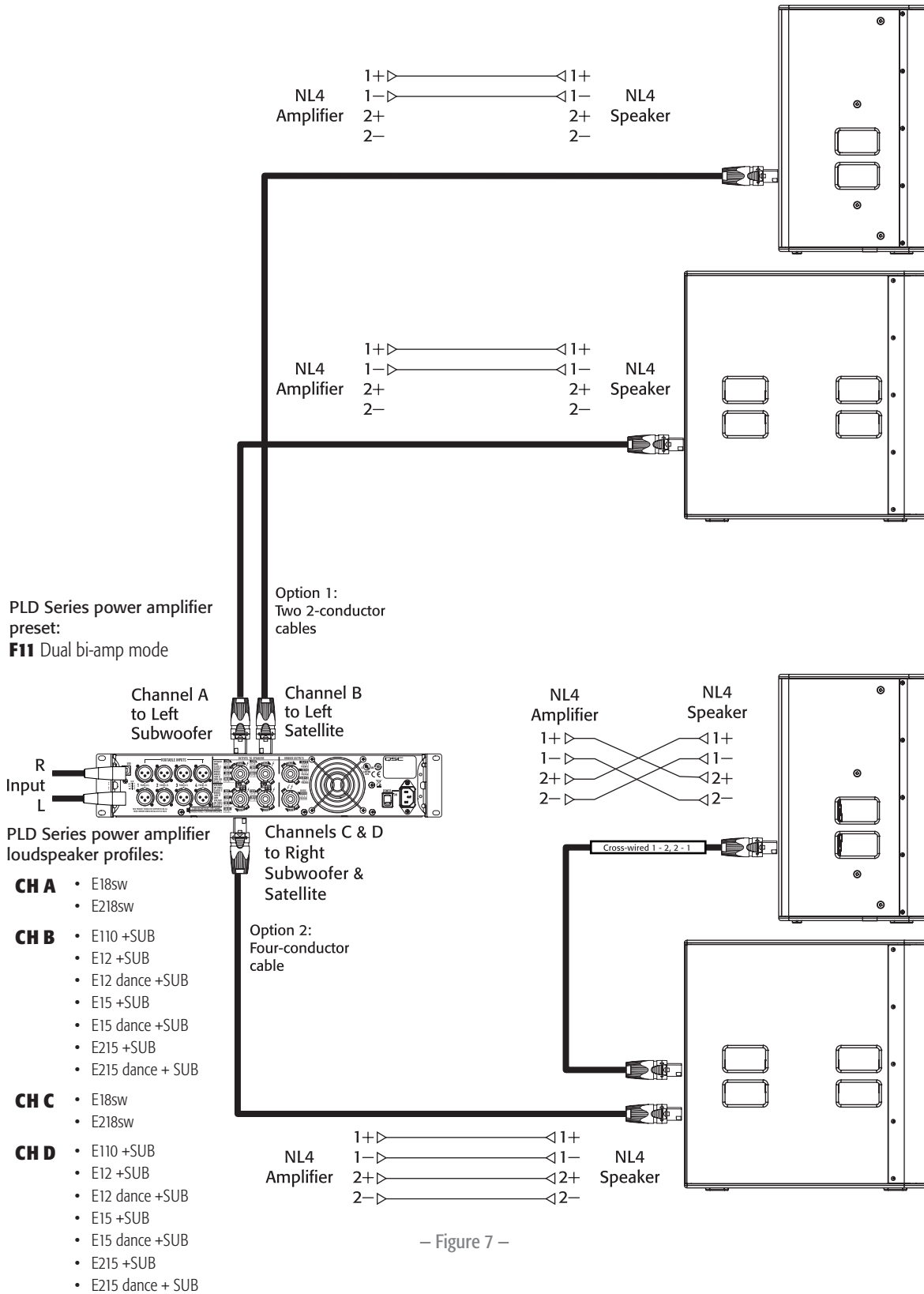

– Figure 7 –

## Pole Mounting

The E Series loudspeakers (E110, E12, E15) can be mounted above the E18sw or E218sw subwoofer using the 24-inch pole included with the subwoofer.

**NOTE:** The E215 loudspeaker does not offer a pole mounting option.



**WARNING!** This pole, if used inappropriately, may make the loudspeaker system top-heavy and hazardous. Ensure that your system will resist tipping and that it sits on a solid, level surface.



**WARNING!** Always use two persons to lift the loudspeaker onto the pole. Do not move a subwoofer if a loudspeaker and pole are mounted on it.

Refer to – Figure 8

1. Place the subwoofer (1) on a solid level surface positioned where you want to use it.
2. Screw the threaded end of the 24-inch mounting pole (3) clockwise into the pole-mounting bracket (2) on top of the subwoofer. Hand tighten only.
3. Select one of the two pole mount cups on the E Series loudspeaker:
  - The rear cup (4) has no tilt.
  - The front cup (5) gives a downward tilt of 10°.
4. Carefully place the loudspeaker onto the pole.

## Installation Options

The following options require purchasing an accessory kit designed for the E Series loudspeakers.

### Yoke Mounting the Loudspeakers

A yoke accessory allows the E110, E12, or E15 to be mounted on a surface, such as a wall or ceiling. The E18-sw and E218-sw subwoofers cannot be yoke-mounted. Each model has a corresponding yoke accessory kit:

- E110 Yoke Accessory Kit **E110 Yoke**
- E12 Yoke Accessory Kit **E12 Yoke**
- E15 Yoke Accessory Kit **E15 Yoke**

### Suspending the Loudspeakers

A pair of E110, E12, and E15 loudspeakers can be suspended using the M8 Suspension Kit **M8 KIT A**, which contains six eye bolts and six washers.

To suspend an E215 loudspeaker, use the **M10 KIT-W**, which contains three eye bolts.

The E18sw and E218sw subwoofers cannot be suspended.

Always consult a licensed and qualified rigger or structural engineer before suspending any loudspeaker.

### Subwoofer Casters and Kits

Optional casters are available to install on the subwoofer models to make them more mobile and ideal for use in portable sound systems.

The E18sw subwoofer uses a kit of four 3-inch casters with 16 mounting screws, QSC part number FG-000972-00 (one kit needed per subwoofer).

The E218sw subwoofer uses a kit of two locking and two non-locking 4-inch casters with 16 mounting screws, QSC part number FG-901156-00 (one kit needed per subwoofer).

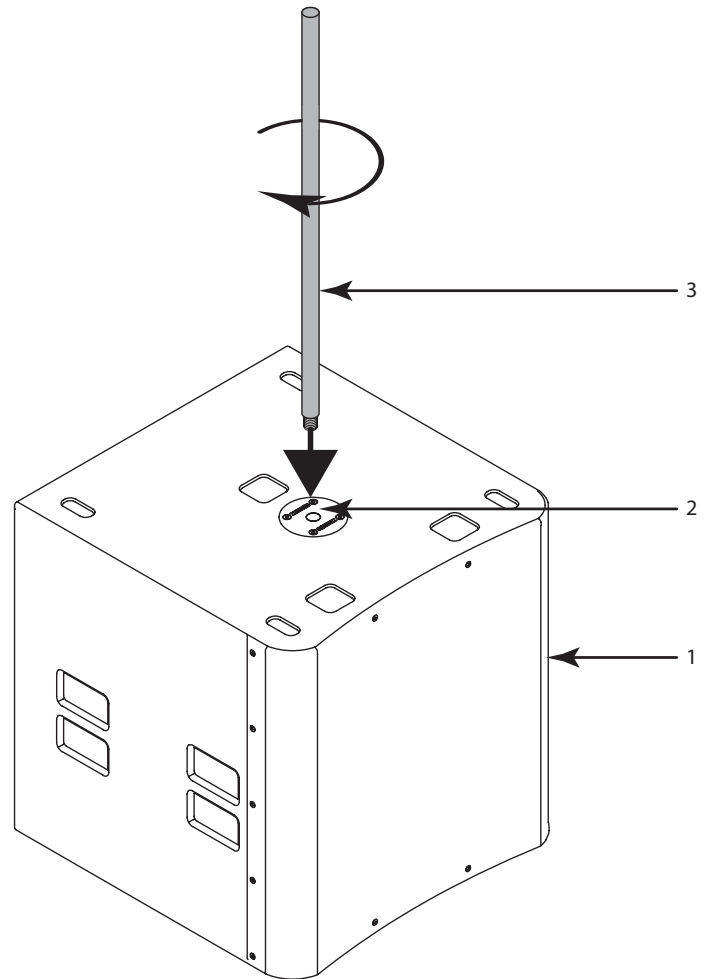
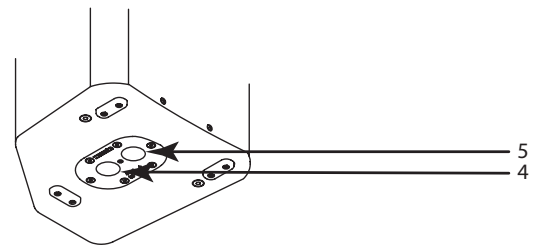

– Figure 8 –



Mailing Address:

QSC, LLC  
1675 MacArthur Boulevard  
Costa Mesa, CA 92626-1468 USA

Telephone Numbers:

Main Number: +1 (714) 754-6175  
Sales & Marketing: +1 (714) 957-7100 or toll free (USA only) (800) 854-4079  
Customer Service: +1 (714) 957-7150 or toll free (USA only) (800) 772-2834

Facsimile Numbers:

Sales & Marketing FAX: +1 (714) 754-6174  
Customer Service FAX: +1 (714) 754-6173

World Wide Web:

[www.qsc.com](http://www.qsc.com)

E-mail:

[info@qsc.com](mailto:info@qsc.com)  
[service@qsc.com](mailto:service@qsc.com)  
[tech\\_support@qsc.com](mailto:tech_support@qsc.com)

© 2016 QSC, LLC. All rights reserved. QSC and the QSC logo are registered trademarks of QSC, LLC in the U.S. Patent and Trademark office and other countries. All other trademarks are the property of their respective owners.

<http://patents.qsc.com>.