

U-MATCH IV SERIES DC INVERTER AIR CONDITIONERS SERVICE MANUAL

**T1/R410A/50Hz
(GC201609 - I)**

CONTENTS

PRODUCT	2
1 MODELS LIST	2
1.1 Outdoor Unit.....	2
1.2 Indoor Unit	3
2 NOMENCLATURE	4
2.1 Outdoor Unit.....	4
2.2 Indoor Unit	4
3 PRODUCT DATA.....	5
3.1 Product Data of Indoor Unit.....	5
3.2 Operation Range.....	14
3.3 Electrical Data.....	14
4 PIPING DIAGRAM.....	15
CONTROL.....	18
1 OPERATION FLOWCHART	18
1.1 Cooling/Dry Operation	18
1.2 Heating Operation.....	19
2 WIRELESS REMOTE CONTROLLER	20
2.1 Operation and Display View.....	20
3 WIRED CONTROLLER	22
3.1 Display View	22
3.2 Operation View	25
4 OPERATION INSTRUCTION OF SPECIAL FUNCTIONS	28
4.1 Setting of Filter Clean Reminder Function	28
4.2 Low Temperature Drying Function.....	30
4.3 Lock Function.....	30
4.4 Memory Function	30
4.5 Door Control Function/Human Sensitive Function	30
4.6 Switch between Fahrenheit and Centigrade	30
4.7 Enquiry of Ambient Temperature	31
4.8 Enquiry of Historical Malfunction	31
4.9 Debugging Function.....	31
5 INSTALLATION OF WIRED CONTROLLER	34
5.1 Standard Accessories.....	34
5.2 Installation Position and Requirement.....	35
5.3 Installation of Wired Controller.....	35
5.4 Removal of Wired Controller.....	36
6 TROUBLESHOOTING	36
6.1 Display of Error Code.....	36
7 CENTRALIZED CONTROLLER	38
7.1 Smart Zone Controller.....	38
7.2 Additional Special Functions.....	40
INSTALLATION.....	55
1 INDOOR UNIT INSTALLATION.....	55
1.1 Installation of Duct Type.....	55
1.2 Installation of Floor Ceiling Type	64
1.3 Installation of Cassette Type	71
2 OUTDOOR UNIT INSTALLATION	80
2.1 Before Installation	80
2.2 Installation Site.....	80
2.3 Caution for Installation	81
2.4 Dimension Data	82
3 REFRIGERATION PIPING WORK.....	83
3.1 Refrigeration Piping Work Procedures and Caution in Connecting.....	83
3.2 Specification of Connection Pipe	87
4 ELECTRIC WIRING WORK	88
4.1 Wiring Precautions.....	88
4.2 Electrical Wiring	88
MAINTENANCE	94
1 TROUBLE TABLE	94
1.1 Main Control Malfunction	94
2 FLOW CHART OF TROUBLESHOOTING	97
2.1 Troubleshooting Flow Chart of Main Control Malfunction.....	97
2.2 Troubleshooting Flow Chart of Drive Malfunction.....	104
2.3 Interface.....	109
2.4 IPM, PFC Testing Method.....	114
3 WIRING DIADRAM.....	118

3.1 Outdoor unit	118
3.2 Indoor unit	123
4 DISASSEMBLY AND ASSEMBLY PROCEDURE OF MAIN PARTS	127
4.1 Outdoor Unit	127
4.2 Indoor Unit	133
5 EXPLODED VIEWS AND SPARE PART LIST	146
5.1 Outdoor Unit	146
5.2 Indoor Unit	158

PRODUCT

PRODUCT

1 MODELS LIST

1.1 Outdoor Unit

Model Name	Product Code	Power Supply (V, Ph, Hz)	Appearance
GUHD09NK3FO	CF090W0630	220-240V~ 50Hz	
GUHD12NK3FO	CF090W0640	220-240V~ 50Hz	
GUHD18NK3FO	CF090W0650	220-240V~ 50Hz	
GUHD24NK3FO	CF090W0660	220-240V~ 50Hz	
GUHD30NK3FO	CF090W0670	220-240V~ 50Hz	
GUHD36NK3FO	CF090W0680	220-240V~ 50Hz	
GUHD36NM3FO	CF090W0690	380-415V 3N~ 50Hz	
GUHD42NK3FO	CF090W0700	220-240V~ 50Hz	
GUHD42NM3FO	CF090W0710	380-415V~ 3N 50Hz	
GUHD48NK3FO	CF090W0720	220-240V~ 50Hz	
GUHD48NM3FO	CF090W0730	380-415V 3N~ 50Hz	
GUHD60NM3FO	CF090W0740	380-415V 3N~ 50Hz	

1.2 Indoor Unit

Type	Model Name	Product Code	Nominal Capacity Cooling/Heating (kW)	Power Supply (V, Ph, Hz)	Appearance	
Duct Type	GFH09K3FI	CF060N0420	2.7/2.9	220-240V~ 50Hz		
	GFH12K3FI	CF060N0430	3.5/3.8			
	GFH18K3FI	CF060N0440	5.0/5.6			
	Duct Type	GFH24K3FI	CF060N0450	7.0/8.0	220-240V~ 50Hz	
		GFH30K3FI	CF060N0460	8.3/9.2		
		GFH36K3FI	CF060N0470	10.0/12.0	220-240V~ 50Hz	
		GFH42K3FI	CF060N0480	11.5/13.5		
		GFH48K3FI	CF060N0490	14.0/15.5	220-240V~ 50Hz	
		GFH60K3FI	CF060N0500	16.0/16.5		
Cassette Type		GKH12K3FI	ET010N0670	3.5/3.8	220-240V~ 50Hz	
		GKH18K3FI	ET010N0680	5.0/5.5		
		GKH24K3FI	ET010N0690	7.0/8.0		
	GKH30K3FI	ET010N0740	8.3/9.2			
	Cassette Type	GKH36K3FI	ET010N0700	10.0/12.0	220-240V~ 50Hz	
		GKH42K3FI	ET010N0710	11.0/12.5		
		GKH48K3FI	ET010N0720	14.0/16.0		
		GKH60K3FI	ET010N0730	16.0/17.0		
Ceiling Type	GTH09K3FI	ED020N0650	2.7/2.9	220-240V~ 50Hz		
	GTH12K3FI	ED020N0660	3.5/3.8			
	GTH18K3FI	ED020N0670	5.0/5.6			
	GTH24K3FI	ED020N0680	7.0/8.0			
	Ceiling Type	GTH30K3FI	ED020N0690	8.5/9.2	220-240V~ 50Hz	
		GTH36K3FI	ED020N0700	10.0/12.0		
		GTH42K3FI	ED020N0710	11.5/13.5		
	Ceiling Type	GTH48K3FI	ED020N0720	14.0/16.0	220-240V~ 50Hz	
		GTH60K3FI	ED020N0730	16.0/17.0		

Note: 1 Ton = 12000Btu/h = 3.517kW

Notes: The universal outdoor units means that the customer can choose any of three kind of indoor unit to match the outdoor unit without any change with it.

2 NOMENCLATURE

2.1 Outdoor Unit

G	U	H	D	09	N	K	3	F	O
1	2	3	4	5	6	7	8	9	10

NO.	Description	Options
1	Gree Electric Appliances Inc	Capital Letter :G
2	Unit Type	U=U-Match Outdoor Unit
3	Product Type	C=Cool Only H=Heat Pump without Aux Electric Heaters
4	Compressor Power Supply Type Code	N=Constant Frequency D=DC Inverter A=AC Inverter
5	Nominal Cooling Capacity	Nominal Cooling Capacity =Number×1000Btu/h
6	Climate Type	N=Climate T1 Condition T= Climate T3 Condition
7	Power Supply Code	K= 220-240V~ 50Hz M=380-415V 3N~ 50Hz
8	Refrigerant	1 =R22; 2=R407C; 3=R410A
9	Design Code	Design Code: A, B, C, D..... Design Change Code=0 (default) 1,2,3.....
10	Unit Code	O=Outdoor unit

2.2 Indoor Unit

G	F	H	09	T	K	3	F	I
1	2	3	4	5	6	7	8	9

NO.	Description	Options
1	Gree Electric Appliances Inc	Capital Letter :G
2	Unit Type	F=Duct Type; K=Cassette Type; T= Floor-ceiling Type
3	Product Type	C=Cool Only H=Heat Pump without Aux Electric Heaters
4	Nominal Cooling Capacity	Nominal Cooling Capacity =Number×1000Btu/h
5	Climate Type	Omit=Climate T1 Condition T= Climate T3 Condition
6	Power Supply Code	K= 220-240V~ 50Hz M=380-415V 3N~ 50Hz
7	Refrigerant	1 =R22; 2=R407C; 3=R410A
8	Design Code	Design Code: A, B, C, D..... Design Change Code= 0 (default) 1,2,3.....
9	Unit Code	I=indoor unite

3 PRODUCT DATA

3.1 Product Data of Indoor Unit

3.1.1 Duct Type

Model	Indoor unit		GFH09K3FI	GFH12K3FI	GFH18K3FI	GFH24K3FI
	Product Code		CF060N0420	CF060N0430	CF060N0440	CF060N0450
	Outdoor unit		GUHD09NK3FO	GUHD12NK3FO	GUHD18NK3FO	GUHD24NK3FO
	Product Code		CF090W0630	CF090W0640	CF090W0650	CF090W0660
Capacity	Cooling Capacity	kW	2.7(0.80-3.40)	3.5(0.90-3.90)	5.0(1.60-5.80)	7.0(2.20-8.50)
	Heating Capacity	kW	2.9(0.80-3.70)	3.8(0.90-4.10)	5.6(1.40-6.80)	8.0(2.40-9.50)
	PdesignH	kW	2.8	3.0	4.5	7.0
Power Input	Cooling	kW	0.84(0.20-1.28)	1.17(0.20-1.40)	1.55(0.55-1.75)	2.18(0.85-2.50)
	Heating	kW	0.80(0.20-1.20)	1.05(0.22-1.20)	1.55(0.50-1.90)	2.21(0.80-2.75)
Design load		-	Average			
SEER / SCOP		W/W	5.6/3.8	5.6/4.0	5.6/3.8	6.1/4.0
Energy Rate(Cooling / Heating)		-	A+/A	A+/A+	A+/A	A++/A+
Indoor Unit			GFH09K3FI	GFH12K3FI	GFH18K3FI	GFH24K3FI
Power Supply		-	220-240V~ 50Hz			
Heat Exchange		-	Cross Fin Coil	Cross Fin Coil	Cross Fin Coil	Cross Fin Coil
Fan	Drive	-	direct	direct	direct	direct
	Motor Output	kW	0.04×1	0.05×1	0.07×1	0.11×1
	Air Flow	m ³ /h	650	750	1000	1400
	Rated Ext. Static Pressure	Pa	25	25	25	25
	Ext. Static Pressure Range	Pa	0~30	0~30	0~30	0~75
Sound Pressure Level(SS/H/M/L)		dB(A)	36/34/28/26	37/36/34/28	40/39/36/28	47/46/44/40
Air Filter		-	PP			PPKZ
Drain		mm	Φ20×1.2	Φ30×1.5	Φ30×1.5	Φ20×1.2
Outline Dimensions (W×H×D)		mm	925×250×665	1037×266×721	1037×266×721	1279×268×558
Net Weight		kg	27	33	33	34
Outdoor Unit			GUHD09NK3FO	GUHD12NK3FO	GUHD18NK3FO	GUHD24NK3FO
Power Supply		-	220-240V~ 50Hz			
Heat Exchange		-	Cross Fin Coil			
Compressor	Type	-	Rotary	Rotary	Rotary	Rotary
	Power Input	W	942	942	1440	2550
Refrigerant	Control	-	Electronic Expansion Valve			
	Charge	kg	1.2	1.2	1.4	2.2
Outline Dimensions (W×H×D)		mm	848×540×320	848×540×320	955×700×396	980×790×427
Net Weight		kg	34	34	47	67
Piping Connections	Liquid	Inch	Φ1/4	Φ1/4	Φ1/4	Φ3/8
	Gas	Inch	Φ3/8	Φ3/8	Φ1/2	Φ5/8
	Max. Length	m	20	20	20	30
	Max. Height	m	15	15	15	15

Model	Indoor unit		GFH30K3FI	GFH36K3FI	GFH36K3FI	GFH42K3FI
	Product Code		CF060N0460	CF060N0470	CF060N0470	CF060N0480
	Outdoor unit		GUHD30NK3FO	GUHD36NK3FO	GUHD36NM3FO	GUHD42NK3FO
	Product Code		CF090W0670	CF090W0680	CF090W0690	CF090W0700
Capacity	Cooling Capacity	kW	8.3(2.40-8.70)	10.0(3.20-11.50)	10.0(3.20-11.50)	11.5(3.60-12.50)
	Heating Capacity	kW	9.2(2.40-9.90)	12.0(2.90-14.50)	12.0(2.90-14.50)	13.5(3.90-15.50)
	PdesignH	kW	7.6	10.4	10.4	10.5
Power Input	Cooling	kW	2.67(0.85-2.70)	3.20(0.70-4.50)	3.12(0.85-4.60)	4.00(0.65-4.70)
	Heating	kW	2.57(0.80-2.86)	3.40(0.70-4.60)	3.32(0.65-4.80)	3.90(0.76-4.75)
Design load		-	Average			
SEER / SCOP		W/W	6.1/4.0	5.6/4.0	5.1/4.0	5.6/3.8
Energy Rate(Cooling / Heating)		-	A++/A+	A+/A+	A/A+	A+/A
Indoor Unit			GFH30K3FI	GFH36K3FI	GFH36K3FI	GFH42K3FI
Power Supply		-	220-240V~ 50Hz			
Heat Exchange		-	Cross Fin Coil	Cross Fin Coil	Cross Fin Coil	Cross Fin Coil
Fan	Drive	-	direct	direct	direct	direct
	Motor Output	kW	0.11×1	0.23×1	0.23×1	0.23×1
	Air Flow	m ³ /h	1400	2100	2100	2100
	Rated Ext. Static Pressure	Pa	37	37	37	37
	Ext. Static Pressure Range	Pa	0~75	0~100	0~100	0~100
Sound Pressure Level(SS/H/M/L)		dB(A)	47/46/44/40	53/52/48/44	53/52/48/44	53/52/48/44
Air Filter		-	PPKZ			
Drain Piping		mm	Φ20×1.2	Φ20×1.2	Φ20×1.2	Φ20×1.2
Outline Dimensions (W×H×D)		mm	1279×268×558	1226×290×775	1226×290×775	1226×290×775
Net Weight		kg	34	46	46	46
Outdoor Unit			GUHD30NK3FO	GUHD36NK3FO	GUHD36NM3FO	GUHD42NK3FO
Power Supply		-	220-240V~ 50Hz		380-415V 3N~50Hz	220-240V~ 50Hz
Heat Exchange		-	Cross Fin Coil			
Compressor	Type	-	Rotary	Rotary	Rotary	Rotary
	Power Input	W	2550	4150	4000	4150
Refrigerant	Control	-	Electronic Expansion Valve			
	Charge	kg	2.4	3.5	3.5	3.7
Outline Dimensions (W×H×D)		mm	980×790×427	1107×1100×440	1107×1100×440	958×1349×412
Net Weight		kg	71	92	98	95
Piping Connections	Liquid	Inch	Φ3/8	Φ3/8	Φ3/8	Φ3/8
	Gas	Inch	Φ5/8	Φ5/8	Φ5/8	Φ5/8
	Max. Length	m	30	30	30	50
	Max. Height	m	15	15	15	30

Model	Indoor unit		GFH42K3FI	GFH48K3FI	GFH48K3FI	GFH60K3FI
	Product Code		CF060N0480	CF060N0490	CF060N0490	CF060N0500
	Outdoor unit		GUHD42NM3FO	GUHD48NK3FO	GUHD48NM3FO	GUHD60NM3FO
	Product Code		CF090W0710	CF090W0720	CF090W0730	CF090W0740
Capacity	Cooling Capacity	kW	11.5(3.60-12.50)	14.0(6.00-14.50)	14.0(6.00-14.50)	16.0(6.80~17.5)
	Heating Capacity	kW	13.5(3.90-15.50)	15.5(5.20-17.00)	15.5(5.20-17.00)	16.5(5.3~18.80)
	PdesignH	kW	10.5	11.8	11.9	13.0
Power Input	Cooling	kW	4.00(0.70-4.80)	4.70(1.40-5.60)	5.10(1.40-5.60)	5.60(1.40-6.60)
	Heating	kW	3.90(0.76-4.75)	4.40(1.30-5.50)	4.50(1.30-5.50)	4.57(1.30-6.40)
Design load		-	Average			
SEER / SCOP		W/W	5.6/4.0	6.1/3.8	5.6/3.8	5.6/3.8
Energy Rate(Cooling / Heating)		-	A+/A+	A++/A	A+/A	A+/A
Indoor Unit			GFH42K3FI	GFH48K3FI	GFH48K3FI	GFH60K3FI
Power Supply		-	220-240V~ 50Hz			
Heat Exchange		-	Cross Fin Coil	Cross Fin Coil	Cross Fin Coil	Cross Fin Coil
Fan	Drive	-	direct	direct	direct	direct
	Motor Output	kW	0.23×1	0.25×1	0.25×1	0.28×1
	Air Flow	m ³ /h	2100	2400	2400	3000
	Rated Ext. Static Pressure	Pa	37	50	50	50
	Ext. Static Pressure Range	Pa	0~100	0~125	0~125	0~150
Sound Pressure Level(SS/H/M/L)		dB(A)	53/52/48/44	55/53/49/45	55/53/49/45	57/56/54/49
Air Filter		-	PPKZ			
Drain Piping		mm	Φ20×1.2	Φ20×1.2	Φ20×1.2	Φ20×1.2
Outline Dimensions (W×H×D)		mm	1226×290×775	1340×350×750	1340×350×750	1340×350×750
Net Weight		kg	46	56	56	57
Outdoor Unit			GUHD42NM3FO	GUHD48NK3FO	GUHD48NM3FO	GUHD60NM3FO
Power Supply		-	380-415V 3N~50Hz	220-240V~ 50Hz	380-415V 3N~ 50Hz	
Heat Exchange		-	Cross Fin Coil			
Compressor	Type	-	Rotary	Rotary	Rotary	Rotary
	Power Input	W	4000	4580	4580	4580
Refrigerant	Control	-	Electronic Expansion Valve			
	Charge	kg	3.7	4.0	4.0	5.0
Outline Dimensions (W×H×D)		mm	958×1349×412	958×1349×412	958×1349×412	1085×1365×427
Net Weight		kg	108	105	114	126
Piping Connections	Liquid	Inch	Φ3/8	Φ3/8	Φ3/8	Φ3/8
	Gas	Inch	Φ5/8	Φ5/8	Φ5/8	Φ3/4
	Max. Length	m	50	50	50	50
	Max. Height	m	30	30	30	30

3.1.2 Cassette Type

Model	Indoor unit		GKH12K3FI	GKH18K3FI	GKH24K3FI
	Product Code		ET010N0670	ET010N0680	ET010N0690
	Outdoor unit		GUHD12NK3FO	GUHD18NK3FO	GUHD24NK3FO
	Product Code		CF090W0640	CF090W0650	CF090W0660
Capacity	Cooling Capacity	kW	3.5(0.90-3.90)	5.0(1.60-5.50)	7.0(2.40-8.50)
	Heating Capacity	kW	3.8(0.90-4.10)	5.5(1.40-6.50)	8.0(2.40-9.50)
	PdesignH	kW	3.0	4.5	7.2
Power Input	Cooling	kW	1.09(0.30-1.40)	1.60(0.55-1.75)	2.18(0.85-2.50)
	Heating	kW	1.05(0.22-1.20)	1.58(0.50-1.90)	2.21(0.80-2.75)
Design load		-	Average		
SEER / SCOP		W/W	5.6/4.0	5.6/3.8	6.1/4.0
Energy Rate(Cooling / Heating)		-	A+/A+	A+/A	A++/A+
Indoor Unit			GKH12K3FI	GKH18K3FI	GKH24K3FI
Power Supply		-	220-240V~50Hz		
Heat Exchange		-	Cross Fin Coil	Cross Fin Coil	Cross Fin Coil
Fan	Drive	-	direct	direct	direct
	Motor Output	kW	0.03×1	0.04×1	0.065×1
	Air Flow	m ³ /h	700	760	1300
Sound Pressure Level(SS/H/M/L)		dB(A)	46/45/41/36	47/46/44/37	47/46/42/38
Air Filter		-	PP		ABS+PP
Drain Piping		mm	Φ25×1.5	Φ25×1.5	Φ25×1.5
Outline Dimensions (W×H×D)		mm	596×240×596	596×240×596	840×240×840
Net Weight		kg	20	20	26
Outdoor Unit			GUHD12NK3FO	GUHD18NK3FO	GUHD24NK3FO
Power Supply		-	220-240V~50Hz		
Heat Exchange		-	Cross Fin Coil		
Compressor	Type	-	Rotary	Rotary	Rotary
	Power Input	W	942	1440	2550
Refrigerant	Control	-	Electronic Expansion Valve		
	Charge	kg	1.2	1.4	2.2
Outline Dimensions (W×H×D)		mm	848×540×320	955×700×396	980×790×427
Net Weight		kg	34	47	67
Piping Connections	Liquid	Inch	Φ1/4	Φ1/4	Φ3/8
	Gas	Inch	Φ3/8	Φ1/2	Φ5/8
	Max. Length	m	20	20	30
	Max. Height	m	15	15	15

Model	Indoor unit		GKH30K3FI	GKH36K3FI	GKH36K3FI	GKH42K3FI
	Product Code		ET010N0740	ET010N0700	ET010N0700	ET010N0710
	Outdoor unit		GUHD30NK3FO	GUHD36NK3FO	GUHD36NM3FO	GUHD42NK3FO
	Product Code		CF090W0670	CF090W0680	CF090W0690	CF090W0700
Capacity	Cooling Capacity	kW	8.3(2.60-9.20)	10.0(3.20-11.50)	10.0(3.20-11.50)	11.0(3.30-12.00)
	Heating Capacity	kW	9.2(2.40-9.90)	12.0(2.90-14.50)	12.0(2.90-14.50)	12.5(3.60-15.00)
	PdesignH	kW	7.6	10.4	10.4	9.5
Power Input	Cooling	kW	2.67(0.85-2.70)	3.20(0.75-4.50)	3.12(0.70-4.70)	3.90(0.53-4.65)
	Heating	kW	2.57(0.80-2.86)	3.50(0.60-4.80)	3.32(0.60-4.80)	3.80(0.64-4.80)
Design load		-	Average			
SEER / SCOP		W/W	6.1/4.0	6.1/4.0	6.1/4.0	5.6/4.0
Energy Rate(Cooling / Heating)		-	A++/A+	A++/A+	A++/A+	A+/A+
Indoor Unit			GKH30K3FI	GKH36K3FI	GKH36K3FI	GKH42K3FI
Power Supply		-	220-240V~ 50Hz			
Heat Exchange		-	Cross Fin Coil	Cross Fin Coil	Cross Fin Coil	Cross Fin Coil
Fan	Drive	-	direct	direct	direct	direct
	Motor Output	kW	0.065×1	0.11×1	0.11×1	0.11×1
	Air Flow	m ³ /h	1500	1860	1860	1860
Sound Pressure Level(SS/H/M/L)		dB(A)	49/48/45/40	51/49/46/43	51/49/46/43	51/49/46/43
Air Filter		-	ABS+PP			
Drain Piping		mm	Φ25×1.5	Φ25×1.5	Φ25×1.5	Φ25×1.5
Outline Dimensions (W×H×D)		mm	840×320×840	840×320×840	840×320×840	840×320×840
Net Weight		kg	31	31	31	31
Outdoor Unit			GUHD30NK3FO	GUHD36NK3FO	GUHD36NM3FO	GUHD42NK3FO
Power Supply		-	220-240V~ 50Hz		380-415V 3N~ 50Hz	220-240V~ 50Hz
Heat Exchange		-	Cross Fin Coil			
Compressor	Type	-	Rotary	Rotary	Rotary	Rotary
	Power Input	W	2550	4150	4000	4150
Refrigerant	Control	-	Electronic Expansion Valve			
	Charge	kg	2.4	3.5	3.5	3.7
Outline Dimensions (W×H×D)		mm	980×790×427	1107×1100×440	1107×1100×440	958×1349×412
Net Weight		kg	71	92	98	95
Piping Connections	Liquid	Inch	Φ3/8	Φ3/8	Φ3/8	Φ3/8
	Gas	Inch	Φ5/8	Φ5/8	Φ5/8	Φ5/8
	Max. Length	m	30	30	30	50
	Max. Height	m	15	15	15	30

Model	Indoor unit		GKH42K3FI	GKH48K3FI	GKH48K3FI	GKH60K3FI
	Product Code		ET010N0710	ET010N0720	ET010N0720	ET010N0730
	Outdoor unit		GUHD42NM3FO	GUHD48NK3FO	GUHD48NM3FO	GUHD60NM3FO
	Product Code		CF090W0710	CF090W0720	CF090W0730	CF090W0740
Capacity	Cooling Capacity	kW	11.0(3.30-12.00)	14.0(6.00-14.80)	14.0(6.00-14.80)	16.0(6.5~16.5)
	Heating Capacity	kW	12.5(3.60-15.00)	16.0(5.20-18.00)	16.0(5.20-18.00)	17.0(5.2~20.0)
	PdesignH	kW	9.5	12.0	11.8	13.0
Power Input	Cooling	kW	3.90(0.60-4.70)	4.60(1.30-5.50)	5.15(1.30-5.50)	5.70(1.30-6.50)
	Heating	kW	3.80(0.64-4.80)	4.50(1.20-5.40)	4.50(1.20-5.40)	4.70(1.20-6.50)
Design load		-	Average			
SEER / SCOP		W/W	6.1/4.0	6.1/3.8	5.6/3.8	6.1/4.0
Energy Rate(Cooling / Heating)		-	A++/A+	A++/A	A+/A	A++/A+
Indoor Unit			GKH42K3FI	GKH48K3FI	GKH48K3FI	GKH60K3FI
Power Supply		-	220-240V~ 50Hz			
Heat Exchange		-	Cross Fin Coil	Cross Fin Coil	Cross Fin Coil	Cross Fin Coil
Fan	Drive	-	direct	direct	direct	direct
	Motor Output	kW	0.11×1	0.15×1	0.15×1	0.15×1
	Air Flow	m ³ /h	1860	2300	2300	2400
Sound Pressure Level(SS/H/M/L)		dB(A)	51/49/46/43	53/52/47/41	53/52/47/41	55/53/47/41
Air Filter		-	ABS+PP			
Drain Piping		mm	Φ25×1.5	Φ25×1.5	Φ25×1.5	Φ25×1.5
Outline Dimensions (W×H×D)		mm	840×320×840	910×290×910	910×290×910	910×290×910
Net Weight		kg	31	43	43	43
Outdoor Unit			GUHD42NM3FO	GUHD48NK3FO	GUHD48NM3FO	GUHD60NM3FO
Power Supply		-	380-415V 3N~50Hz	220-240V~ 50Hz	380-415V 3N~ 50Hz	
Heat Exchange		-	Cross Fin Coil			
Compressor	Type	-	Rotary	Rotary	Rotary	Rotary
	Power Input	W	4000	4580	4580	4580
Refrigerant	Control	-	Electronic Expansion Valve			
	Charge	kg	3.7	4.0	4.0	5.0
Outline Dimensions (W×H×D)		mm	958×1349×412	958×1349×412	958×1349×412	1085×1365×427
Net Weight		kg	108	105	114	126
Piping Connections	Liquid	Inch	Φ3/8	Φ3/8	Φ3/8	Φ3/8
	Gas	Inch	Φ5/8	Φ5/8	Φ5/8	Φ3/4
	Max. Length	m	50	50	50	50
	Max. Height	m	30	30	30	30

3.1.3 Floor-ceiling Type

Model	Indoor unit		GTH09K3FI	GTH12K3FI	GTH18K3FI	GTH24K3FI
	Product Code		ED020N0650	ED020N0660	ED020N0670	ED020N0680
	Outdoor unit		GUHD09NK3FO	GUHD12NK3FO	GUHD18NK3FO	GUHD24NK3FO
	Product Code		CF090W0630	CF090W0640	CF090W0650	CF090W0660
Capacity	Cooling Capacity	kW	2.7(0.80-3.50)	3.5(0.90-3.90)	5.0(1.60-5.80)	7.0(2.40-8.20)
	Heating Capacity	kW	2.9(0.80-3.80)	3.8(0.90-4.10)	5.6(1.40-6.80)	8.0(2.40-9.00)
	PdesignH	kW	2.9	3.0	4.5	7.0
Power Input	Cooling	kW	0.84(0.20-1.28)	1.09(0.26-1.40)	1.55(0.55-1.75)	2.18(0.85-2.50)
	Heating	kW	0.80(0.20-1.20)	1.05(0.22-1.20)	1.55(0.50-1.90)	2.21(0.80-2.75)
Design load		-	Average			
SEER / SCOP		W/W	6.1/3.8	6.1/4.0	6.1/4.0	5.6/4.0
Energy Rate(Cooling / Heating)		-	A++/A	A++/A+	A++/A+	A+/A+
Indoor Unit			GTH09K3FI	GTH12K3FI	GTH18K3FI	GTH24K3FI
Power Supply		-	220-240V~ 50Hz			
Heat Exchange		-	Cross Fin Coil	Cross Fin Coil	Cross Fin Coil	Cross Fin Coil
Fan	Drive	-	direct	direct	direct	direct
	Motor Output	kW	0.015×1	0.02×1	0.04×1	0.065×1
	Air Flow	m ³ /h	600	700	1000	1200
Sound Pressure Level(SS/H/M/L)		dB(A)	31/29/26/24	35/33/30/27	44/42/38/32	49/48/46/40
Air Filter		-	PP			
Drain Piping		mm	Φ17×1.75	Φ17×1.75	Φ17×1.75	Φ17×1.75
Outline Dimensions (W×H×D)		mm	1220×225×700	1220×225×700	1220×225×700	1220×225×700
Net Weight		kg	38	39	39	40
Outdoor Unit			GUHD09NK3FO	GUHD12NK3FO	GUHD18NK3FO	GUHD24NK3FO
Power Supply		-	220-240V~ 50Hz			
Heat Exchange		-	Cross Fin Coil			
Compressor	Type	-	Rotary	Rotary	Rotary	Rotary
	Power Input	W	942	942	1440	2550
Refrigerant	Control		Electronic Expansion Valve			
	Charge	kg	1.2	1.2	1.4	2.2
Outline Dimensions (W×H×D)		mm	848×540×320	848×540×320	955×700×396	980×790×427
Net Weight		kg	34	34	47	67
Piping Connections	Liquid	Inch	Φ1/4	Φ1/4	Φ1/4	Φ3/8
	Gas	Inch	Φ3/8	Φ3/8	Φ1/2	Φ5/8
	Max. Length	m	20	20	20	30
	Max. Height	m	15	15	15	15

Model	Indoor unit		GTH30K3FI	GTH36K3FI	GTH36K3FI	GTH42K3FI
	Product Code		ED020N0690	ED020N0700	ED020N0700	ED020N0710
	Outdoor unit		GUHD30NK3FO	GUHD36NK3FO	GUHD36NM3FO	GUHD42NK3FO
	Product Code		CF090W0670	CF090W0680	CF090W0690	CF090W0700
Capacity	Cooling Capacity	kW	8.5(2.60-9.20)	10.0(3.20-11.50)	10.0(3.20-11.50)	11.5(3.60-12.50)
	Heating Capacity	kW	9.2(2.40-9.90)	12.0(2.90-14.50)	12.0(2.90-14.50)	13.5(3.90-15.50)
	PdesignH	kW	7.6	10.4	10.4	10.5
Power Input	Cooling	kW	2.67(0.85-2.70)	3.20(0.80-4.60)	3.12(0.75-4.70)	3.90(0.60-4.70)
	Heating	kW	2.57(0.80-2.86)	3.40(0.65-4.80)	3.32(0.60-4.80)	3.70(0.69-4.80)
Design load		-	Average			
SEER / SCOP		W/W	6.1/4.0	6.1/4.0	6.1/4.0	6.1/4.0
Energy Rate(Cooling / Heating)		-	A++/A+	A++/A+	A++/A+	A++/A+
Indoor Unit			GTH30K3FI	GTH36K3FI	GTH36K3FI	GTH42K3FI
Power Supply		-	220-240V~ 50Hz			
Heat Exchange		-	Cross Fin Coil	Cross Fin Coil	Cross Fin Coil	Cross Fin Coil
Fan	Drive	-	direct	direct	direct	direct
	Motor Output	kW	0.09×1	0.14×1	0.14×1	0.165×1
	Air Flow	m ³ /h	1500	1900	1900	1900
Sound Pressure Level(SS/H/M/L)		dB(A)	49/46/44/38	54/53/51/46	54/53/51/46	55/54/52/47
Air Filter		-	PP			
Drain Piping		mm	Φ17×1.75	Φ17×1.75	Φ17×1.75	Φ17×1.75
Outline Dimensions (W×H×D)		mm	1420×245×700	1420×245×700	1420×245×700	1420×245×700
Net Weight		kg	48	48	48	50
Outdoor Unit			GUHD30NK3FO	GUHD36NK3FO	GUHD36NM3FO	GUHD42NK3FO
Power Supply		-	220-240V~ 50Hz		380-415V 3N~ 50Hz	220-240V~ 50Hz
Heat Exchange		-	Cross Fin Coil			
Compressor	Type	-	Rotary	Rotary	Rotary	Rotary
	Power Input	W	2550	4150	4000	4150
Refrigerant	Control	-	Electronic Expansion Valve			
	Charge	kg	2.4	3.4	3.5	3.7
Outline Dimensions (W×H×D)		mm	980×790×427	1107×1100×440	1107×1100×440	958×1349×412
Net Weight		kg	71	92	98	95
Piping Connections	Liquid	Inch	Φ3/8	Φ3/8	Φ3/8	Φ3/8
	Gas	Inch	Φ5/8	Φ5/8	Φ5/8	Φ5/8
	Max. Length	m	30	30	30	50
	Max. Height	m	15	15	15	30

Model	Indoor unit		GTH42K3FI	GTH48K3FI	GTH48K3FI	GTH60K3FI
	Product Code		ED020N0710	ED020N0720	ED020N0720	ED020N0730
	Outdoor unit		GUHD42NM3FO	GUHD48NK3FO	GUHD48NM3FO	GUHD60NM3FO
	Product Code		CF090W0710	CF090W0720	CF090W0730	CF090W0740
Capacity	Cooling Capacity	kW	11.5(3.60-12.50)	14.0(6.00-14.80)	14.0(6.00-14.80)	16.0(6.35~16.5)
	Heating Capacity	kW	13.5(3.90-15.50)	16.0(5.20-18.00)	16.0(5.20-18.00)	17.0(5.50~20.0)
	PdesignH	kW	10.5	11.8	11.8	13.00
Power Input	Cooling	kW	3.90(0.60-4.75)	4.80(1.40-5.60)	5.00(1.40-5.60)	5.75(1.40-6.60)
	Heating	kW	3.74(0.69-4.80)	4.30(1.30-5.50)	4.50(1.30-5.50)	4.70(1.30-6.50)
Design load		-	Average			
SEER / SCOP		W/W	5.6/4.0	5.6/3.8	5.6/4.0	5.1/4.0
Energy Rate(Cooling / Heating)		-	A+/A+	A+/A	A+/A+	A+/A+
Indoor Unit			GTH42K3FI	GTH48K3FI	GTH48K3FI	GTH60K3FI
Power Supply		-	220-240V~ 50Hz			
Heat Exchange		-	Cross Fin Coil	Cross Fin Coil	Cross Fin Coil	Cross Fin Coil
Fan	Drive	-	direct	direct	direct	direct
	Motor Output	kW	0.165×1	0.19×1	0.19×1	0.20×1
	Air Flow	m ³ /h	1900	2300	2300	2500
Sound Pressure Level(SS/H/M/L)		dB(A)	55/54/52/47	56/55/50/46	56/55/50/46	58/56/52/46
Air Filter		-	PP			
Drain Piping		mm	Φ17×1.75	Φ17×1.75	Φ17×1.75	Φ17×1.75
Outline Dimensions (W×H×D)		mm	1420×245×700	1700×245×700	1700×245×700	1700×245×700
Net Weight		kg	50	59	59	59
Outdoor Unit			GUHD42NM3FO	GUHD48NK3FO	GUHD48NM3FO	GUHD60NM3FO
Power Supply		-	380-415V 3N~ 50Hz	220-240V~ 50Hz	380-415V 3N~ 50Hz	
Heat Exchange		-	Cross Fin Coil			
Compressor	Type	-	Rotary	Rotary	Rotary	Rotary
	Power Input	W	4000	4580	4580	4580
Refrigerant	Control	-	Electronic Expansion Valve			
	Charge	kg	3.7	4.0	4.0	5.0
Outline Dimensions (W×H×D)		mm	958×1349×412	958×1349×412	958×1349×412	1085×1365×427
Net Weight		kg	108	105	114	126
Piping Connections	Liquid	Inch	Φ3/8	Φ3/8	Φ3/8	Φ3/8
	Gas	Inch	Φ5/8	Φ5/8	Φ5/8	Φ3/4
	Max. Length	m	50	50	50	50
	Max. Height	m	30	30	30	30

Note: Nominal capacities are based on the follow conditions.

Mode		Indoor	Outdoor
Cooling		DB:27(80.6) WB:19(66.2)	DB:35(95) WB:24(75.2)
Heating		DB:20(68) WB:--(--)	DB:7(44.6) WB:6(42.8)
Piping Length	09k-42k	5m	
	48k-60k	7.5m	

The air volume is measured at the relevant standard external static pressure.

Noise is tested in the semianechoic room, so it should be slightly higher in the actual operation due to environmental change.

3.2 Operation Range

Mode	Range of Outdoor Temperature
Cooling	-15-48
Heating	-10-24

3.3 Electrical Data

3.3.1 Outdoor unit

Table 1-4-1 Electrical Data of Outdoor Unit

Model	Compressor			Fan Motor	Fuse Capacity (Main board)	Breaker Capacity	Min. Power Supply Cord
	Power Supply	Qty.	RLA	FLA			
	V/Ph/Hz	-	A	A			
GUHD09NK3FO	220-240,1,50	1	4.5	<1	3.15	13	1.5
GUHD12NK3FO		1	4.5	<1	3.15	13	1.5
GUHD18NK3FO		1	7.2	<1	5	16	1.5
GUHD24NK3FO		1	11.5	<1	5	20	2.5
GUHD30NK3FO		1	11.5	<1	5	20	2.5
GUHD36NK3FO		1	8	<1	5	25	2.5
GUHD42NK3FO		1	8	<1	5	25	2.5
GUHD48NK3FO		1	21	<1	5	40	6.0
GUHD36NM3FO	380-415,3,50	1	7.8	<1	5	10	1.5
GUHD42NM3FO		1	7.8	<1	5	10	1.5
GUHD48NM3FO		1	24	<1	5	16	1.5
GUHD60NM3FO		1	24	<1	5	16	1.5

3.3.2 Indoor unit

Table 1-4-2 Electrical Data of Indoor Unit

Model	Power Supply	Fan Motor FLA	Fuse/Breaker Capacity	Min. Power Supply Cord
	V/Ph/Hz	A	A	mm ²
GFH09K3FI	220-240,1,50	<1	5/6	1.0
GTH09K3FI	220-240,1,50	<1	5/6	1.0
GFH12K3FI	220-240,1,50	<1	5/6	1.0
GTH12K3FI	220-240,1,50	<1	5/6	1.0
GKH12K3FI	220-240,1,50	<1	5/6	1.0
GFH18K3FI	220-240,1,50	<1	5/6	1.0
GTH18K3FI	220-240,1,50	<1	5/6	1.0
GKH18K3FI	220-240,1,50	<1	5/6	1.0
GFH24K3FI	220-240,1,50	<1	5/6	1.0
GTH24K3FI	220-240,1,50	<1	5/6	1.0
GKH24K3FI	220-240,1,50	<1	5/6	1.0
GFH30K3FI	220-240,1,50	<1	5/6	1.0
GTH30K3FI	220-240,1,50	<1	5/6	1.0
GKH30K3FI	220-240,1,50	<1	5/6	1.0
GFH36K3FI	220-240,1,50	<1	5/6	1.0
GTH36K3FI	220-240,1,50	<1	5/6	1.0
GKH36K3FI	220-240,1,50	<1	5/6	1.0
GFH42K3FI	220-240,1,50	<1	5/6	1.0
GTH42K3FI	220-240,1,50	<1	5/6	1.0
GKH42K3FI	220-240,1,50	<1	5/6	1.0
GFH48K3FI	220-240,1,50	<1	5/6	1.0
GTH48K3FI	220-240,1,50	<1	5/6	1.0
GFH60K3FI	220-240,1,50	<1	5/6	1.0
GTH60K3FI	220-240,1,50	<1	5/6	1.0

Notes:

RLA: Rated load amperes

LRA: Locked rotor amperes

FLA: Full load current

- ① Install the disconnect device with a contact gap of at least 3mm in all poles nearby the units (Both indoor unit and outdoor unit).The appliance must be positioned so that the plug is accessible.
- ② The specifications of the breaker and power cable listed in the table above are determined based on the maximum power (maximum amps) of the unit.
- ③ The specifications of the power cable listed in the table above are applied to the conduit-guarded multi-wire copper cable (like, YJV copper cable, consisting of PE insulated wires and a PVC cable jacket) used at 40°C and resistible to 90°C (see IEC 60364-5-52). If the working condition

changes, they should be modified according to the related national standard.

- ④ The specifications of the breaker listed in the table above are applied to the breaker with the working temperature at 40°C. If the working condition changes, they should be modified according to the related national standard.

4 PIPING DIAGRAM

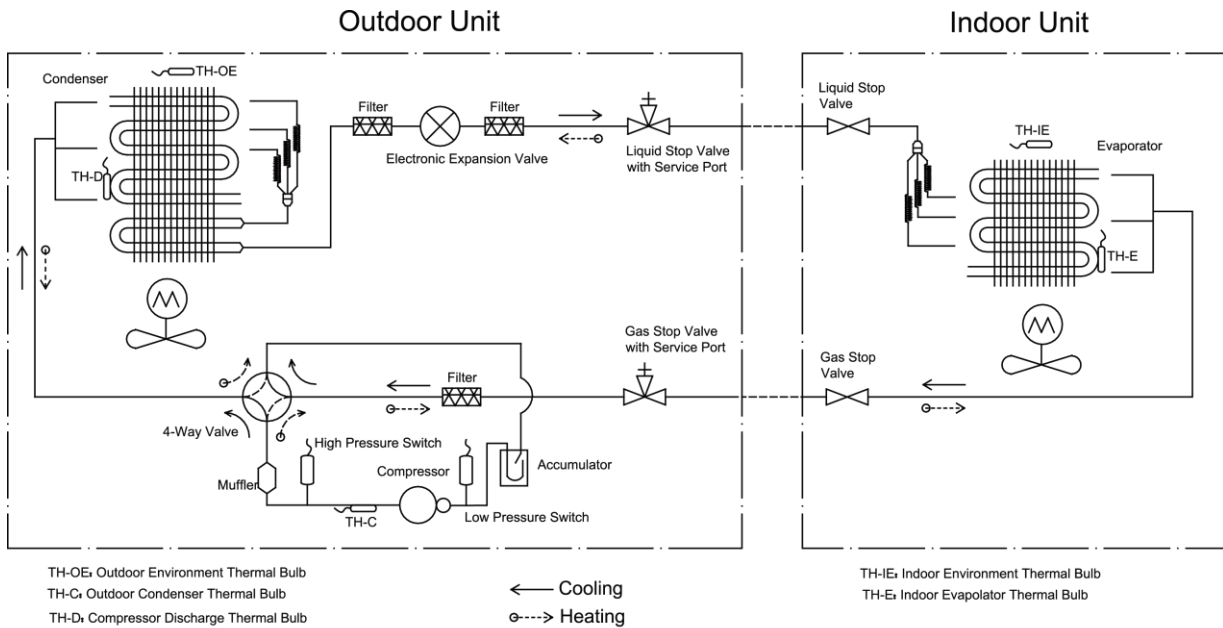

Note:

- 1. it is just a schematic diagram and some parts may differ from the real objects inside the unit.
- 2. The throttling device for units 09K and 12K is the capillary rather than the electronic expansion valve.

CONTROL

CONTROL

1 OPERATION FLOWCHART

1.1 Cooling/Dry Operation

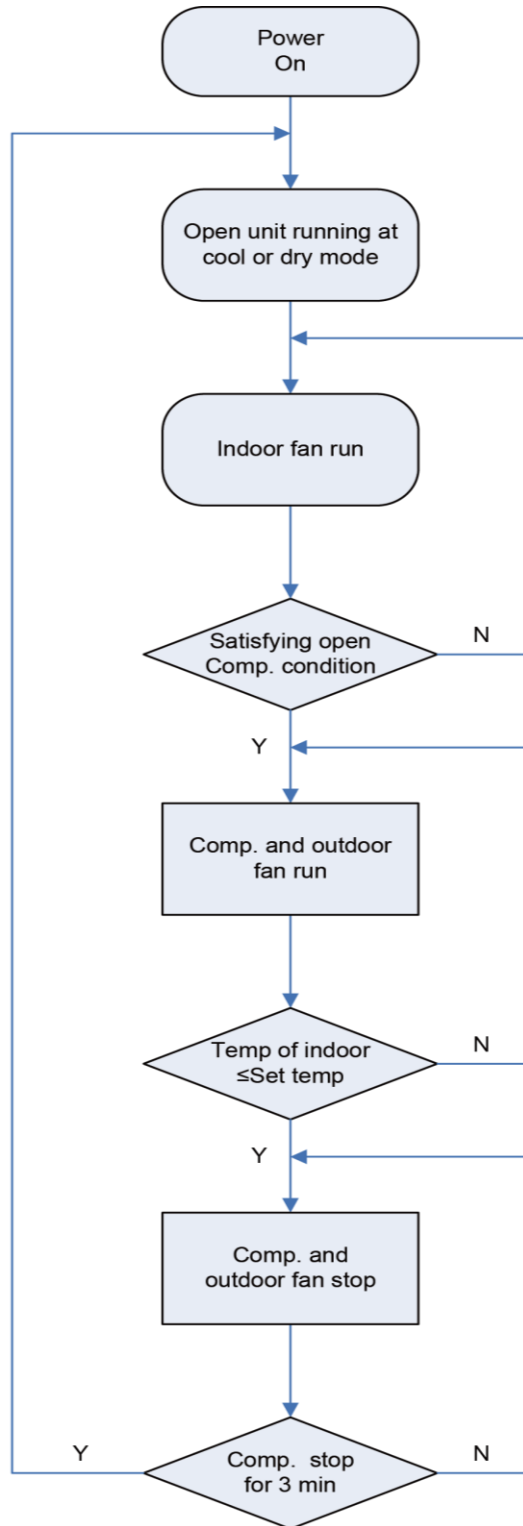

1.2 Heating Operation

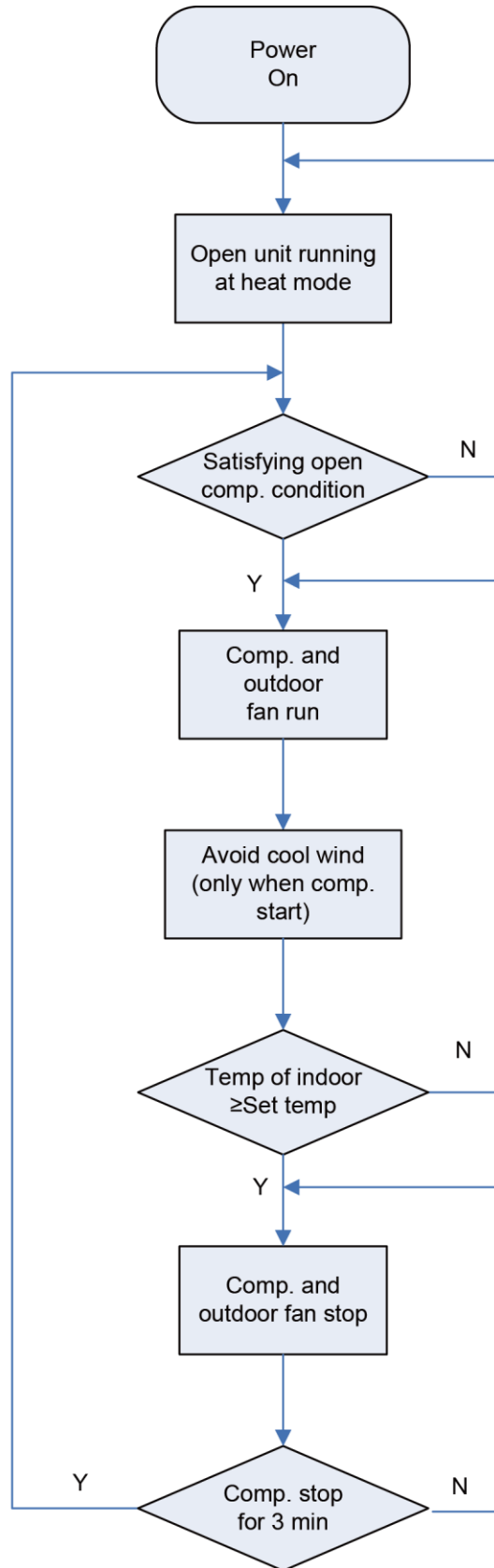

2 WIRELESS REMOTE CONTROLLER

2.1 Operation and Display View

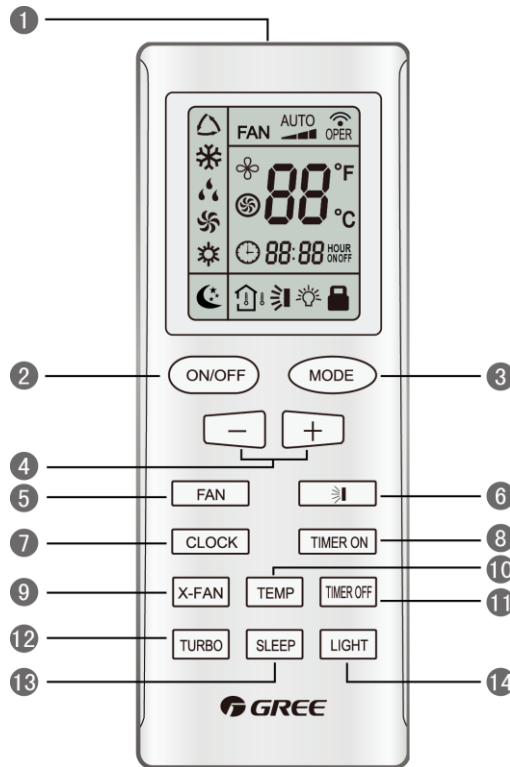
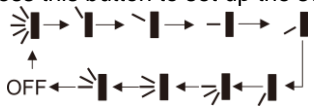















Table 2-2-1 Operation instruction of wireless remote controller

No.	Name	Function Description
1	Signal transmitter	● Signal transmitter
2	ON/OFF button	● Press this button and the unit will be turned on; press it once more and the unit will be turned off. When turning off the unit, the Sleep function will be canceled, but the presetting time is still remained.
3	MODE button	<ul style="list-style-type: none"> ● By pressing this button, Auto, Cool, Dry, Fan, Heat mode can be selected circularly. Auto mode is default after power on. Under the Auto mode, the setting temperature will not be displayed; Under the Heat mode, the initial value is 28°C (82°F); under other modes, the initial value is 25°C (77°F). <p>△ AUTO; ❄️ COOL; 💧 DRY; 🌀 FAN; ☀️ HEAT (only for cooling and heating unit)</p>
4	- button	● Preset temperature can be decreased by pressing this button. Pressing and holding this button for more than 2 seconds can make the temperature changed quickly until release this button and then transmit this order. The temperature adjustment is unavailable under the Auto mode, but the order can be sent by pressing this button. Centigrade setting range: 16-30; Fahrenheit scale setting range 61-86.
	+ button	● Preset temperature can be increased by pressing this button. Pressing and holding this button for more than 2 seconds can make the temperature changed quickly until release the button and then transmit this order. The temperature adjustment is unavailable under the Auto mode, but the order can be sent by pressing this button. Centigrade setting range: 16-30; Fahrenheit scale setting range 61-86.
5	FAN button	<ul style="list-style-type: none"> ● By pressing this button, Auto, Low, Middle, High speed can be circularly selected. After power on, Auto fan speed is default. <p> Low speed Middle speed High speed </p> <p>Note: Under the DRY mode, the fan will be kept running at the low speed and the fan speed isn't adjustable.</p>

<p>6</p>	<p>SWING UP/DOWN button</p>	<ul style="list-style-type: none"> ● Press this button to set up the swing angle, which circularly changes as below:  ● When the guide louver starts to swing up and down, if SWING functions are canceled, the air guide louver will stop and remains at the current position. ●  Indicates the guide louver swings up and down among those five directions. (Simplified SWING function applicable for some Fan Coil Units: When the wireless remote controller is energized initially with the unit under the OFF status, it should be set by pressing the + button and the SWING button simultaneously, with the symbol  blinking twice. Then, after the unit is turned on, this function can be activated by pressing the SWING button, with the displayed symbol  indicating swing function is on and without this displayed symbol indicating swing function is off.)
<p>7</p>	<p>CLOCK button</p>	<ul style="list-style-type: none"> ● By pressing this button, the clock is allowed to be set, with  blinking, and then press the +/- button to adjust the clock within 5 seconds. If the +/- button is pressed down constantly for more than 2 seconds, the clock setting will be increased or decreased 10 minutes every 0.5 seconds. After that, another press on the CLOCK button accepts the setting. 12:00 is the default, when the wireless remote controller is energized.
<p>8</p>	<p>TIMER ON button</p>	<ul style="list-style-type: none"> ● When TIMER ON is activated, ON will blink while the symbol  will disappear. Within 5 seconds it is allowed to set the ON time by pressing the +/- button. Each press will make the time increase or decrease one minute. Besides, the time can also be set by pressing the +/- button constantly. That is, in the early 2.5 seconds, the time will increase/decrease quickly per single minute, and in the late 2.5, the time will increase/decrease per ten minutes. After the desired time value is set, press TIENE ON again to conform the setting within five seconds. After that, another press on TIMER ON will cancel the setting. Prior to this setting, the clock shall be set to the actual time.
<p>9</p>	<p>X-FAN button</p>	<ul style="list-style-type: none"> ● Pressing this button can activate or deactivate the X-FAN function. In Cool or Dry mode, by pressing this button, if "" is displayed, it indicates the X-FAN function is activated. By repressing this button, if "" disappears, it indicates the X-FAN function is deactivated. After energization, X-FAN OFF is defaulted. If the unit is turned off, X-FAN can be deactivated but can't be activated.
<p>10</p>	<p>TEMP button</p>	<ul style="list-style-type: none"> ● By pressing this button it is allowed to select displaying the indoor setting temperature or the indoor ambient temperature. ● Indoor setting temperature is default after the indoor unit is energized initially. ● By pressing the TEMP button, when the temperature symbol  is displayed, the indoor displayer will show the indoor setting temperature; when  is displayed, it will show the indoor ambient temperature; when  is invalidation, If current displays indoor ambient temperature, if received the other remote control signal, it will display presetting temperature, 5s later, will back to display the ambient temperature. (This function is applicable to partial of models)
<p>11</p>	<p>TIMER OFF button</p>	<ul style="list-style-type: none"> ● By pressing this button it is available to go to the TIMER OFF setting state with the same setting method as that of the TIMER ON, in which case the OFF symbol blinks.
<p>12</p>	<p>TURBO button</p>	<ul style="list-style-type: none"> ● In the Cool or Heat mode, pressing this button can activate or deactivate the TURBO function. When the TURBO function is activated, its symbol  will be displayed; when the running mode or the fan speed is changed, this function will be canceled automatically. (This function is applicable to partial of models).
<p>13</p>	<p>SLEEP button</p>	<ul style="list-style-type: none"> ● By pressing this button, Sleep On and Sleep Off can be selected. After powered on, Sleep Off is defaulted. Once the unit is turned off, the Sleep function is canceled. When Sleep is set to on, the symbol of SLEEP  will display. Under the Fan and Auto modes, this function is not available.
<p>14</p>	<p>LIGHT button</p>	<ul style="list-style-type: none"> ● Press this button to select LIGHT on or off in the displayer. When the LIGHT is set to on, the icon  will be displayed and the indicating light in the displayer will be on. When the LIGHT is set to off, the icon  will be disappeared and the indicating light in the displayer will be off.

3 WIRED CONTROLLER

3.1 Display View

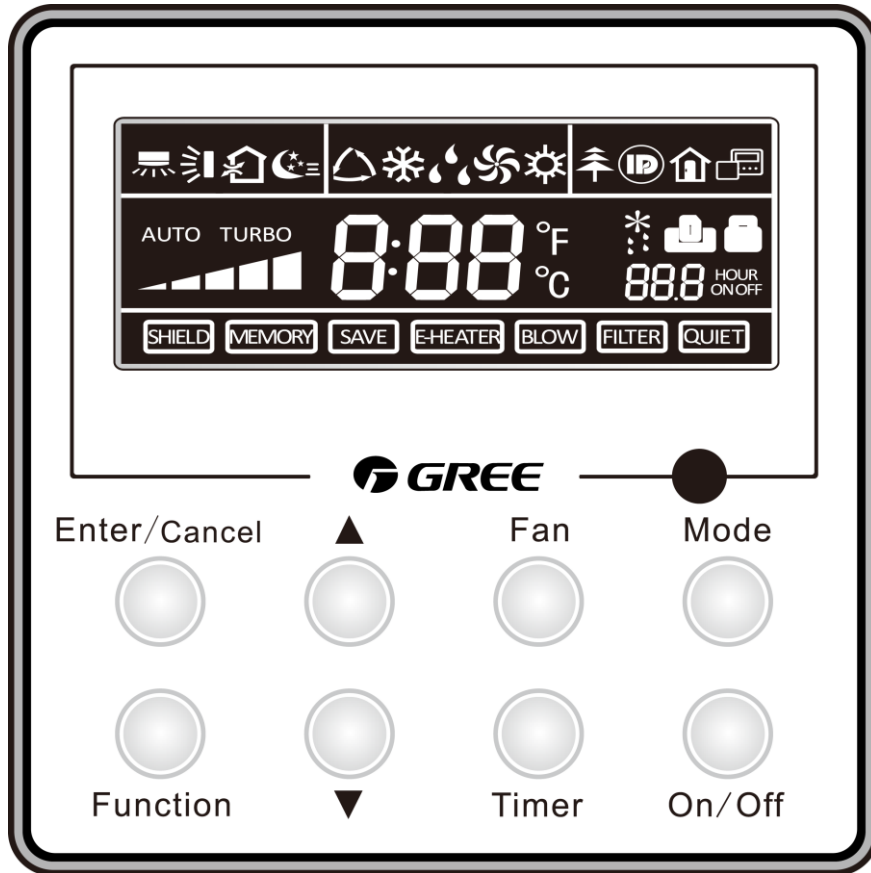

Figure 2-3-1 Appearance of wired controller

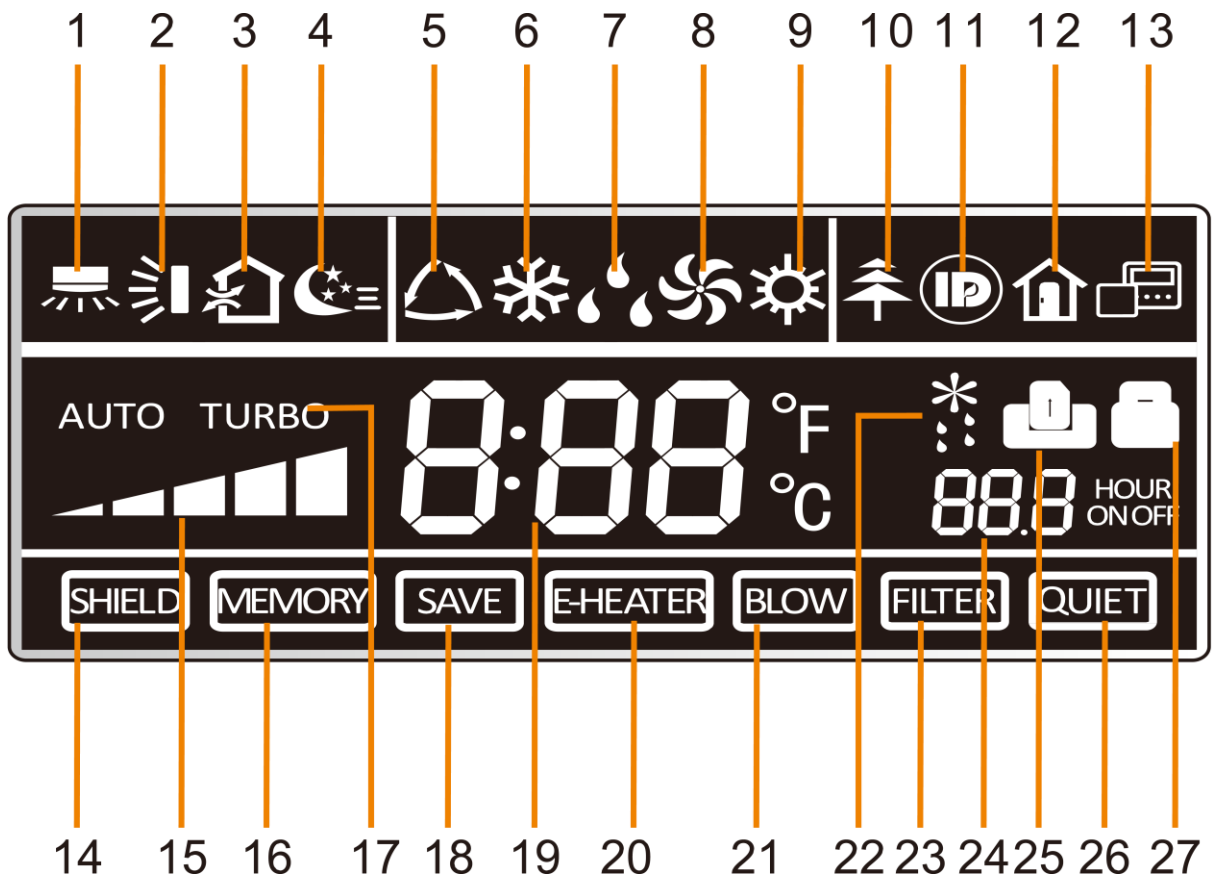

Figure 2-3-2 LCD display of wired controller

Table 2-3-1 Instruction to LCD Display

No.	Icons	Introduction
1		Left and right swing function
2		Up and down swing function
3		Air exchange function
4		Sleep function
5		Auto mode
6		COOL mode
7		DRY mode
8		FAN mode
9		HEAT mode
10		Health function
11		I-Demand function
12		Vacation function
13		Status display of master and slave wired controller
14		Shield function The button operation, temperature setting, "On/Off" operation, "Mode" setting, and "Save" setting are disabled.
15		Fan speed
16		Memory function The unit will resume the original setting state after power recovery.
17		Turbo function
18		Energy-saving function
19		Ambient/setting temperature
20		Electric heater
21		Blow function
22		Defrosting function
23		Filter cleaning
24		Timer Setting
25		Keycard control / Detected status sensed by human body
26		Quiet function
27		Lock function

3.2 Operation View

3.2.1 Silk Screen of Buttons

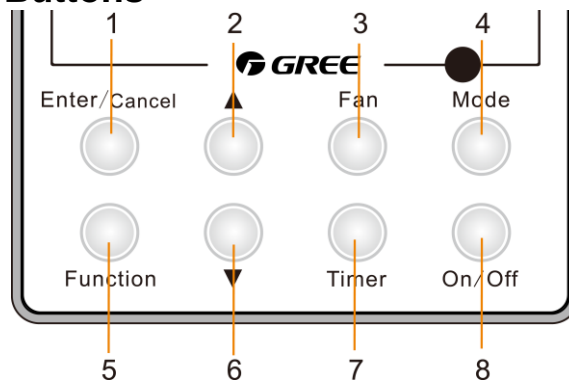

Figure 2-3-3 Silk screen of buttons

3.3.2 Instruction to Function of Buttons

Table 2-3-2 Instruction to buttons of wired controller

No.	Description	Functions
1	Enter/Cancel	(1)Function selection and canceling; (2)Press it for 5s to view the ambient temperature; press Mode button to select viewing outdoor ambient temperature or indoor ambient temperature.
2	▲	(1) Running temperature setting range of indoor unit: 16-30℃; (2) Timer setting range: 0.5-24hr; (3) Setting of air function level; (4) Setting of energy-saving temperature; (5) Setting of cleaning class.
6	▼	
3	Fan	Setting of high/medium high/medium/medium low/low/auto fan speed.
4	Mode	Setting of auto/cooling/heating/fan/dry mode of indoor unit.
5	Function	Switch over among these functions of swing/air/sleep/health/I-Demand/out/turbo/save/e-heater/X-fan/clean/quiet.
7	Timer	Timer setting.
8	On/Off	Turn on/off indoor unit.
4 Mode and 2 ▲	Memory function	Press Mode and ▲ buttons at the same time for 5s under off state of the unit to enter/cancel memory function (If memory function is set, indoor unit will resume original setting state after power failure and then power recovery. If not, indoor unit is defaulted to be off after power recovery. Ex-factory setting of memory function is on).
2 ▲ and 6 ▼	Lock	Upon startup of the unit without malfunction or under off state of the unit, press ▲ and ▼ buttons at the same time for 5s to enter lock state. In this case, any other buttons won't respond when pressing. Repress ▲ and ▼ buttons for 5s to quit lock state.
4 Mode and 5 Function	Enquiry and setting of address of wired controller	Under off state of the unit, press Mode and Function buttons at the same time for 5s to set the address. (More details please refer to project debugging)
5 Function and 7 Timer	Setting of project parameters (More details please refer to the Notes)	Under off state of the unit, press Function and Timer buttons at the same time for 5s to go to the debugging menu. Press Mode button to adjust the setting items and press ▲ or ▼ buttons to set the actual value.
4 Mode and 6 ▼	Switch between Fahrenheit and Centigrade	Under off state of the unit, press Mode and ▼ buttons at the same time for 5s to switch between Fahrenheit and Centigrade.
5 Function and 6 ▼	Viewing historical malfunction	Continuously press Function and ▼ buttons for 5s to view historical malfunction. Then press ▲ and ▼ buttons to adjust displayed contents. The timer displaying position displays the sequence of malfunction and the detailed error code. The 5 th displayed malfunction is the last malfunction.
1 Enter/Cancel and 4 Mode	Setting of master and slave wired controller	Under off state of the unit, press Enter/Cancel and Mode buttons at the same time for 5s to set master and slave wired controller. Press ▲ or ▼ button to adjust. (More details please refer to project debugging)

Notes: The following functions can be set through Function and Timer buttons: setting of ambient temperature sensor, selecting three speeds in high speed and three speeds in low speed of indoor fan motor, display setting of freeze protection error code, setting of cold air prevention and hot air hot prevention function, setting of refrigerant-lacking protection function, selecting of blowing residual heat of indoor unit, selecting of compressor electric heater mode, selecting of low-power consumption mode, selecting door control function, selecting human sensitive function, long-distance monitoring, temperature compensation value at the air return port.

3.2.3 Setting of Wired Controller's Address

3.2.3.1 Enquiry and Setting of Wired Controller's Address

Under off state of the unit, press Function and Mode buttons at the same time for 5s to enter setting interface of wired controller's address. In this case, LCD displays address number. Then press▲ or ▼ button to adjust address and then press Enter/Cancel button to confirm. The address setting is related to the setting of Debugging Function 4.9.10. When the selection in 4.9.10 is 00, address of centralized controller is to be set and the address setting range is 01~16; when the selection in 4.9.10 is 01, address of long-distance monitor is to be set and the address setting range is 01~255.

Enquiry and setting of wired controller's address is shown as Figure 2-3-4 below:

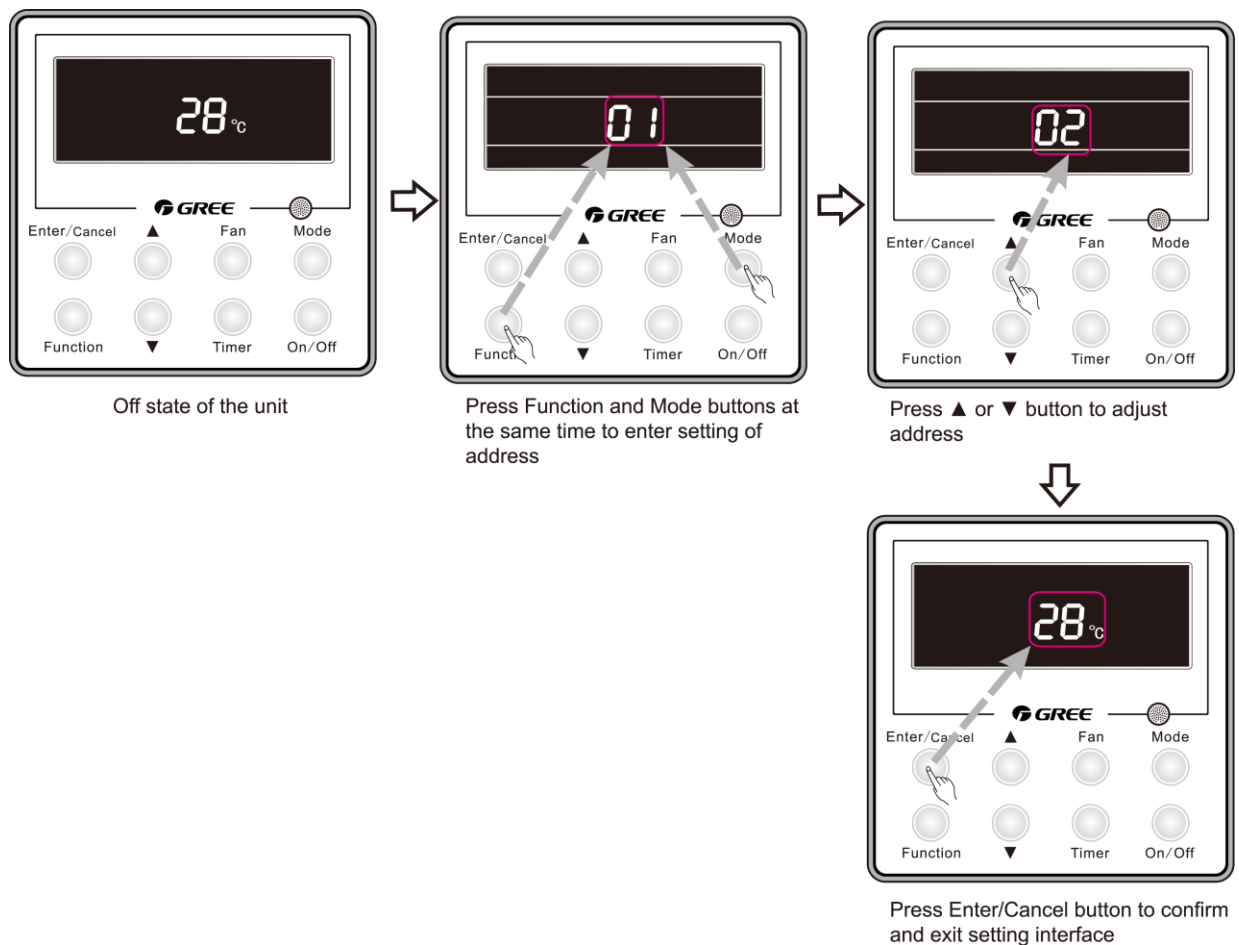



Figure 2-3-4 Enquiry and setting of wired controller's address

3.2.3.2 Setting of Master/Slave Wired Controller's Address

Under off status of the unit, press Enter/Cancel and Mode buttons at the same time for 5s to go to the enquiry and setting interface of master/slave wired controller. In this case, LCD displays wired controller's address (01 for master wired controller and 02 for slave wired controller). Press ▲ or ▼ button to adjust address of master/slave wired controller and then press Enter/Cancel button to confirm. If slave wired controller is set, the icon  will be displayed.

Note: If there is only one wired controller, it only can be set as the master; if there are two wired controllers, one should be the master and the other should be the slave.

Setting of master/slave wired controller's address is shown as Figure 2-3-5 below:

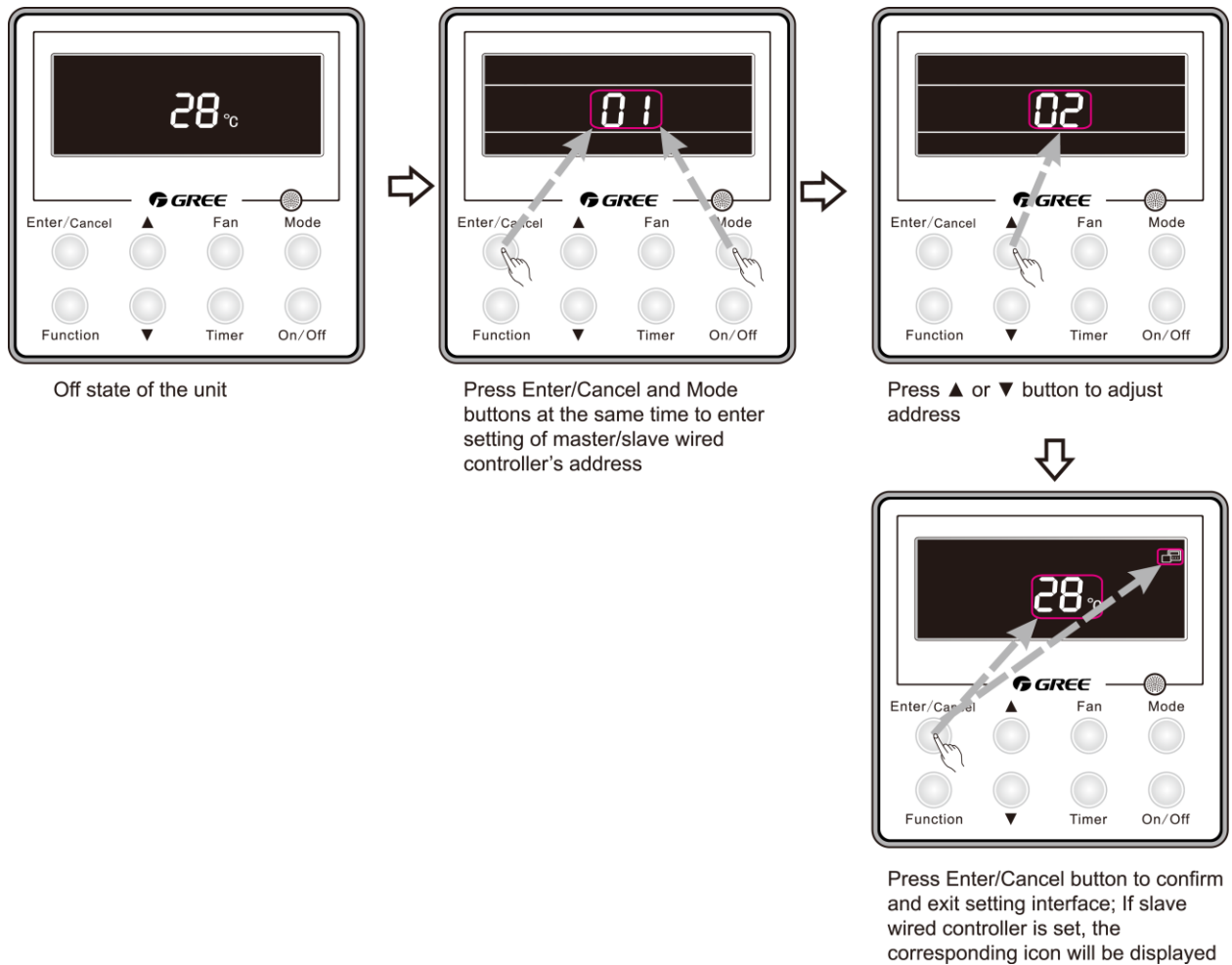

Figure 2-3-5 Enquiry and setting of master/slave wired controller's address

4 OPERATION INSTRUCTION OF SPECIAL FUNCTIONS

4.1 Setting of Filter Clean Reminder Function

When unit is on, press Function button to switch to filter clean reminder function. The **FILTER** icon will blink and then enter setting of filter clean reminder function. Timer zone displays the set pollution level and you can press ▲ or ▼ button to adjust the level. Then press Enter/Cancel button to turn on this function.

When filter clean reminder function is turned on, press Function button to switch to filter clean reminder function. The **FILTER** icon will blink and press ▲ or ▼ button to adjust timer zone to display "00". Then press Enter/Cancel button to cancel this function.

Setting of filter clean reminder function is shown as Figure 2-4-1 below:

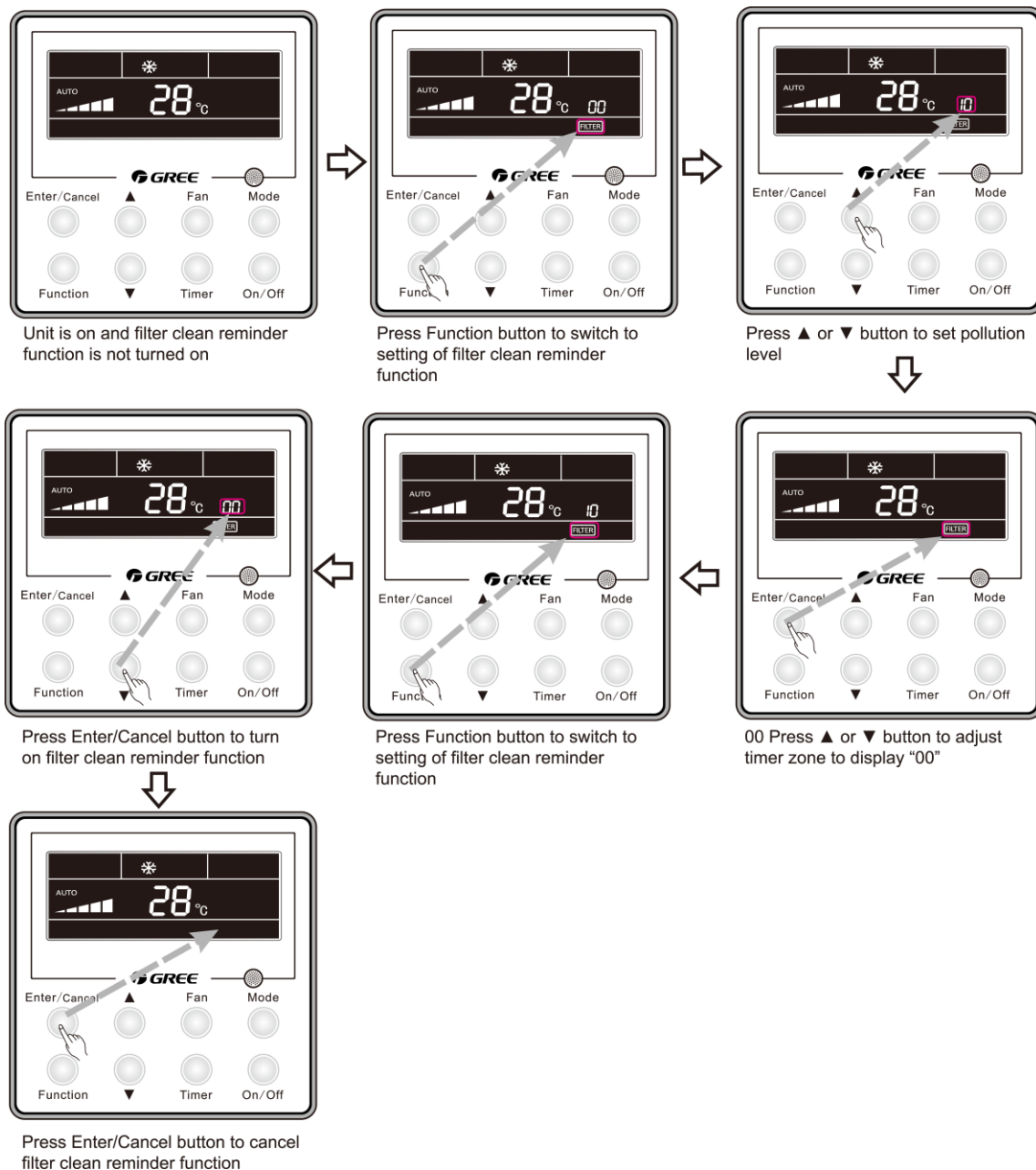

Figure 2-4-1 Setting of filter clean reminder function

When setting the filter clean reminder function, timer zone will display 2 digits, of which the former indicates the pollution degree of operating place and the latter indicates the accumulated operating time of indoor unit. There are 4 types of situations:



- (1) Clean Reminder is off (Timer zone shows “00”).
- (2) Slight pollution: The former digit in timer zone shows 1 while the latter one shows 0, which indicates the accumulated operating time is 5500hr. Each time the latter digit increases 1, the accumulated operating time increases 500hr. When it reaches 9, it means the accumulated operating time is 10000hr.
- (3) Medium pollution: The former digit in timer zone shows 2 while the latter one shows 0, which indicates the accumulated operating time is 1400hr. Each time the latter digit increases 1, the accumulated operating time increases 400hr. When it reaches 9, it means the accumulated operating time is 5000hr.
- (4) Heavy pollution: The former digit in timer zone shows 3 while the latter one shows 0, which indicates the accumulated operating time is 100hr. Each time the latter digit increases 1, the accumulated operating time increases 100hr. When it reaches 9, it means the accumulated operating time is 1000hr.

The detailed pollution level and the corresponding time are as shown in Table 2-4-1 below:

Table 2-4-1 Pollution level and corresponding time

Pollution level	Accumulated operating time (hour)	Pollution level	Accumulated operating time (hour)	Pollution level	Accumulated operating time (hour)
10	5500	20	1400	30	100
11	6000	21	1800	31	200
12	6500	22	2200	32	300
13	7000	23	2600	33	400
14	7500	24	3000	34	500
15	8000	25	3400	35	600
16	8500	26	3800	36	700
17	9000	27	4200	37	800
18	9500	28	4600	38	900
19	10000	29	5000	39	1000

If filter clean reminder function is turned on, the  icon will be on.

- (1) If cleaning time is not reached, no matter the setting is changed or not, the accumulated operating time won't be recalculated when pressing Enter/Cancel button;
- (2) If cleaning time is reached, in unit on or off state,  will blink every 0.5s for reminder. Press Function button to switch to  icon and press ▲ and ▼ button to adjust the level. Then press Enter/Cancel button, so the accumulated operating time won't be cleared (If the adjusted level is higher than the present accumulated operating time, the icon won't blink any more; if the adjusted level is lower than the present accumulated operating time, the icon will go on blinking).
- (3) The only way to cancel filter clean reminder function is to press Function button to switch to filter clean reminder function. The  icon will blink and press ▲ or ▼ button to adjust timer zone to display “00”. In this case, the accumulated operating time will be cleared.

4.2 Low Temperature Drying Function

Under dry mode and when set temperature is 16°C, continuously press ▼ button for twice and then the set temperature will be 12°C. In this case, the unit will enter low temperature drying function.

When low temperature drying function is turned on, press ▲ button or Mode button to exit low temperature drying function.

4.3 Lock Function

When unit is turned on normally or turned off, pressing ▲ and ▼ buttons at the same time for 5s will turn on Lock function. LCD will display . Pressing ▲ and ▼ buttons at the same time for 5s to turn off this function.

When Lock function is turned on, any other buttons won't respond when pressing. The function can be memorized after power failure and then power recovery.

4.4 Memory Function

Press Mode and ▲ buttons at the same time for 5s under off state of the unit to turn on or cancel memory function. If memory function is set,  is displayed. If not, indoor unit is defaulted to be off after power recovery.

If memory function is set, indoor unit will resume original setting state after power failure and then power recovery.

Note: If cut off power with 5s after memorized content is changed, the memorized content may be abnormal. Do not cut off power within 5s after memorized content is changed.

4.5 Door Control Function/Human Sensitive Function

Door control function or human sensitive function can be selected (More details please refer to Debugging Function). These two functions can't be turned on at the same time.

When door control function is selected, the wired controller will work when the room card is inserted and stop working when the room card is not inserted; when human sensitive function is selected, the wired controller will work when it senses there is somebody in the room and stop working when it senses there is nobody in the room. When the door control function senses the room card is not inserted or human sensitive function senses there is nobody in the room, the wired controller will display  icon.

Note:

- ① In long-distance monitoring or centralized control, no matter the room card is inserted or not, the ON/OFF of unit can be controlled. If long-distance monitoring or centralized control information is received when the room card is not inserted,  icon is cleared. When the card is reinserted, door control function is judged to be turned on. If long-distance monitoring or centralized control information is received when the room card is inserted, it will keep the original status.
- ② The unit can not be controlled by buttons when the card is not inserted.
- ③ When door control function and human sensitive function have been set at the same time, it is defaulted that door control function is valid and human sensitive function is invalid.

4.6 Switch between Fahrenheit and Centigrade

Under off state of the unit, press Mode and ▼ buttons at the same time for 5s to switch between Fahrenheit and Centigrade.

4.7 Enquiry of Ambient Temperature

Under off or on state of the unit, press it for 5s to view the ambient temperature. In this case, timer zone displays ambient temperature type 01 or 02. Ambient temperature zone displays the corresponding temperature of that type. 01 stands for outdoor ambient temperature and 02 stands for the indoor ambient temperature after compensation. Press Mode button to switch between 01 and 02. Pressing other buttons except Mode button or receiving remote control signal will exit enquiry state. If there is no operation within 20s will also exit enquiry state.

Note:

- ① If the unit is not connected to outdoor ambient temperature sensor, display of outdoor ambient temperature will be shielding after energizing for 12hr.
- ② If there is malfunction of outdoor ambient temperature sensor, display of outdoor ambient temperature will be shielding after energizing for 12hr.

4.8 Enquiry of Historical Malfunction

Under off or on state of the unit, continuously press Function and ▼ buttons for 5s to view historical malfunction.

In enquiry state, set temperature displaying zone displays “00”. Press ▲ and ▼ buttons to view the 5 malfunctions happened recently. The timer displaying position displays the detailed error code. The 5th displayed malfunction is the last malfunction.

4.9 Debugging Function

Under off state of the unit, press Function and Timer buttons at the same time for 5s to go to the debugging menu. Press Mode button to adjust the setting items and press ▲ or ▼ button to set the actual value.

4.9.1 Setting ambient temperature sensor (dual ambient temperature sensors function)

Under debugging state, press Mode button to adjust to “00” in temperature displaying zone. Timer zone displays setting state and press ▲ or ▼ button to adjust. There are 3 selections:

- (1) The ambient temperature at air return is set as indoor ambient temperature (timer zone displays 01)
- (2) The temperature at wired controller is set as indoor ambient temperature (timer zone displays 02)
- (3) Select the temperature sensor at air return in cooling, dry and fan mode; select the temperature sensor at wired controller in heating and auto mode.

4.9.2 Selecting three speeds in high speed and three speeds in low speed of indoor fan motor

Under debugging state, press Mode button to adjust to “01” in temperature displaying zone. Timer zone displays setting state and press ▲ or ▼ button to adjust. There are 2 selections:

- (1) Three speeds in low speed (LCD displays 01)
- (2) Three speeds in high speed (LCD displays 02)

Three speeds in low speed include high, medium and low speeds; three speeds in high speed include super high, high and medium speed.

Note: For this series, this function is invalid.

4.9.3 Displaying setting of freeze protection error code

Under debugging state, press Mode button to adjust to “02” in temperature displaying zone. Timer zone displays setting state and press ▲ or ▼ button to adjust. There are 2 selections:

- (1) Displayed (LCD displays 01)
- (2) Not displayed (LCD displays 02)

It is defaulted to be not displayed for export unit and be displayed for domestic unit.

4.9.4 Setting refrigerant lacking protection function

Under debugging state, press Mode button to adjust to “04” in temperature displaying zone. Timer zone displays setting state and press ▲ or ▼ button to adjust. There are 2 selections:

- (1) With refrigerant lacking protection function (LCD displays 01)
- (2) Without refrigerant lacking protection function (LCD displays 02)

4.9.5 Selecting blowing residual heating of indoor unit

Under debugging state, press Mode button to adjust to “05” in temperature displaying zone. Timer zone displays setting state and press ▲ or ▼ button to adjust. There are 2 selections:

- (1) Mode 1 (LCD displays 00)
- (2) Mode 2 (LCD displays 01)

Note: Blowing residual heating of indoor unit

Mode 1: Unit stops when reaching temperature point and indoor fan motor does not stop in cooling mode; after unit stops when reaching temperature point in heating mode, duct type unit and floor ceiling unit blow residual heat for 60s and then stop indoor unit, while cassette type unit always operates in low fan speed and blows residual heat for 60s when there is malfunction.

Mode 2: After unit stops when reaching temperature point, the indoor fan motor stops operation with a 10s delay no matter in cooling mode or in heating mode.

4.9.6 Mode selecting of compressor electric heating belt

Under debugging state, press Mode button to adjust to “06” in temperature displaying zone. Timer zone displays setting state and press ▲ or ▼ button to adjust. There are 2 selections:

- (1) Mode 1 (LCD displays 00)
- (2) Mode 2 (LCD displays 01)

Note:

Mode 1: Compressor electric heating belt starts when outdoor ambient temperature is below 35°C and stops when outdoor ambient temperature is above 37°C. When outdoor ambient temperature is within 35°C~ 37°C, the belt will keep its previous operation state.

Mode 2: Compressor electric heating belt starts when outdoor ambient temperature is below -2°C and stops when outdoor ambient temperature is above 0°C. When outdoor ambient temperature is within -2°C~0°C, the belt will keep its previous operation state.

4.9.7 Selecting low-power consumption mode

Under debugging state, press Mode button to adjust to “07” in temperature displaying zone. Timer zone displays setting state and press ▲ or ▼ button to adjust. There are 2 selections:

- (1) With low-power consumption mode (LCD displays 00)
- (2) Without low-power consumption mode (LCD displays 01)

4.9.8 Selecting door control function

Under debugging state, press Mode button to adjust to “08” in temperature displaying zone. Timer zone displays setting state and press ▲ or ▼ button to adjust. There are 2 selections:

- (1) Without door control function (LCD displays 00)
- (2) With door control function (LCD displays 01)

4.9.9 Selecting human sensitive function

Under debugging state, press Mode button to adjust to “09” in temperature displaying zone. Timer zone displays setting state and press ▲ or ▼ button to adjust. There are 2 selections:

- (1) Without human sensitive function (LCD displays 00)
- (2) With human sensitive function (LCD displays 00)

4.9.10 Selecting long-distance monitoring or centralized controller

Under debugging state, press Mode button to adjust to “10” in temperature displaying zone. Timer zone displays setting state and press ▲ or ▼ button to adjust. There are 2 selections:

- (1) Centralized controller (LCD displays 00)
- (2) Long-distance monitoring (LCD displays 01)

4.9.11 Selecting fan mode of indoor fan motor

Under debugging state, press Mode button to adjust to “11” in temperature displaying zone. Timer zone displays setting state and press ▲ or ▼ button to adjust. There are 5 selections:

- (1) P3 (LCD displays 03)
- (2) P4 (LCD displays 04)
- (3) P5 (LCD displays 05)
- (4) P6 (LCD displays 06)
- (5) P7 (LCD displays 07)

Note: You can select P03, P04, P05, P06, P07 in fan mode of indoor fan motor, which means different fan mode combinations are corresponding to different static pressure. Ex-factory defaulted mode is P05. You can set the mode through wired controller. S01, S02, S03.....S12, S13 means the rotation speed of indoor unit is from low to high.

Table 2-4-2 Combination relationship of P03, P04, P05, P06, P07

Static pressure selection	Super high speed	High speed	Medium high speed	Medium speed	Medium low speed	Low speed	Quiet R1 speed	Quiet R2 speed	Quiet R13 speed
P03	S09	S08	S07	S06	S05	S04	S03	S02	S01
P04	S10	S09	S08	S07	S06	S05	S04	S03	S02
P05	S11	S10	S09	S08	S07	S06	S05	S04	S03
P06	S12	S11	S10	S09	S08	S07	S06	S05	S04
P07	S13	S12	S11	S10	S09	S08	S07	S06	S05

4.9.12 Selecting compensation of temperature sensor at air return

Under debugging state, press Mode button to adjust to “12” in temperature displaying zone. Timer zone displays setting state and press ▲ or ▼ button to adjust. There are 16 selections:

- (1) Compensate 0℃ (LCD displays 00)
- (2) Compensate 1℃ (LCD displays 01)
- (3) Compensate 2℃ (LCD displays 02)

- (4) Compensate 3°C (LCD displays 03)
- (5) Compensate 4°C (LCD displays 04)
- (6) Compensate 5°C (LCD displays 05)
- (7) Compensate 6°C (LCD displays 06)
- (8) Compensate 7°C (LCD displays 07)
- (9) Compensate 8°C (LCD displays 08)
- (10) Compensate 9°C (LCD displays 09)
- (11) Compensate 10°C (LCD displays 10)
- (12) Compensate 11°C (LCD displays 11)
- (13) Compensate 12°C (LCD displays 12)
- (14) Compensate 13°C (LCD displays 13)
- (15) Compensate 14°C (LCD displays 14)
- (16) Compensate 15°C (LCD displays 15)

Note: Indoor ambient temperature compensation can be set through wired controller (E.g. If 02 is selected; it indicates the compensation temperature is 2°C. If the indoor ambient temperature detected by the temperature sensor at air return is 29°C, the ambient temperature after compensation is $29^{\circ}\text{C}-2^{\circ}\text{C}=27^{\circ}\text{C}$).

After finishing setting, press Enter/Cancel button to save and exit setting. After entering this interface, the system will exit this menu if there is no operation on the button within 20s. Normal off state interface will be displayed and present setting will not be saved.

5 INSTALLATION OF WIRED CONTROLLER

5.1 Standard Accessories

Table 2-5-1 Standard Accessories of Wired Controller

Description	Quantity	Note
Socket base box installed in the wall	1	No.1 in Figure 2-5-1
Base plate of wired controller	1	No.2 in Figure 2-5-1
Screw M4×25	2	No.3 in Figure 2-5-1
Panel of wired controller	1	No.4 in Figure 2-5-1

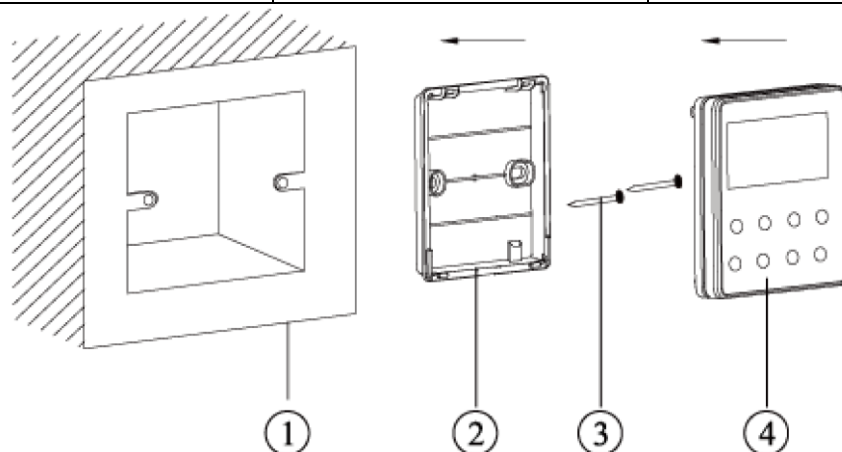

Figure 2-5-1

5.2 Installation Position and Requirement

- (1) Prohibit installing the wired controller at the misty place or the place with direct sunlight.
- (2) Prohibit installing the wired controller at the place near high temperature objects or water-splashing places.
- (3) Prohibit installing the wired controller at the place where faces forward to the window, to avoid interference of another remote controller from neighborhood.
- (4) Cut off the power of heavy current wire in the installation hole of the wall. All power should be cut off during installation.
- (5) In order to avoid abnormal operation due to electromagnetic interference, etc., pay attention to the following notes during connecting wires:
 - 1) Make sure the tie-in interface of communication wire is correct, otherwise it may lead to communication malfunction.
 - 2) The signal wires and communication wires of wired controller should be separated from power cord and connection wire between indoor unit and outdoor unit.
 - 3) If the air conditioner is installed at the strong electromagnetic interference place, signal wire and communication wire of wired controller must use shielding twisted wire.

5.3 Installation of Wired Controller

Firstly, the selection and connection way of wired controller's signal wire are as below:

- (1) Choose suitable signal wire: 2-core signal wire (wire diameter $\geq 0.75\text{mm}$, wire length $< 30\text{m}$ and the recommended length is 8m).
- (2) Make sure the power of indoor unit is cut off; fix the signal wire of wired controller on the wiring board for wired controller of indoor unit with screws; make sure the signal wire is solid.

Then, the detailed installation procedures of wired controller are as shown in Figure 2-5-2:

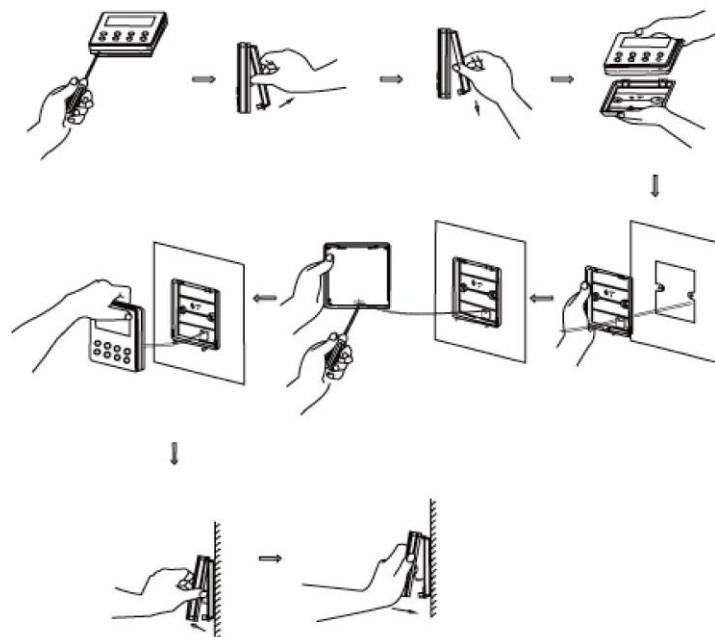

Figure 2-5-2 Installation of wired controller

Brief instructions of installation procedure:

- a) Pull out the 2-core signal wire in the installation hole of the wall and then let this wire go

- through the hole at the back of wired controller's base plate.
- b) Fix the base plate and installation hole of the wall together with screw M4×25.
 - c) Fix the above mentioned 2-core signal wire on the copper insert X1 and X2 with the equipped screws of wired controller.
 - d) Fasten the wired controller's panel with its base plate together.

5.4 Removal of Wired Controller

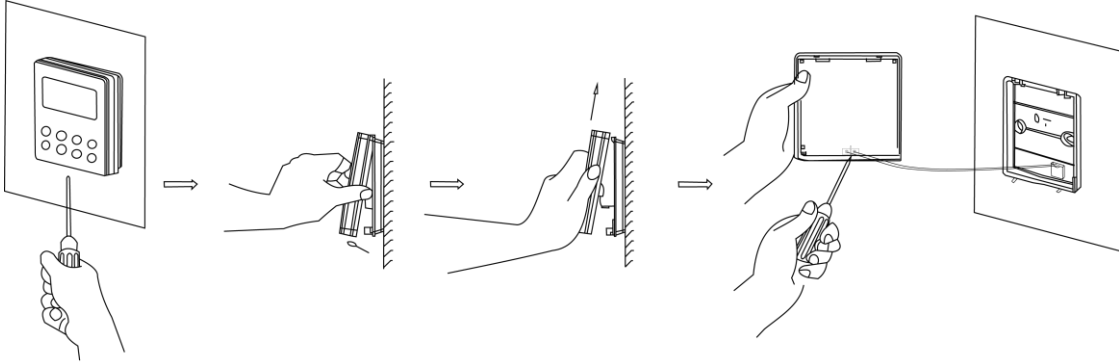

Figure 2-5-3 Removal of wired controller

6 TROUBLESHOOTING

6.1 Display of Error Code

Table 2-6-1 Error Code List

Error Code	Error
E1	Compressor high pressure protection
E2	Freeze protection
E3	Compressor low pressure protection, refrigerant lacking protection, refrigerant recycling mode
E4	Compressor high discharge temperature protection
E6	Communication malfunction
E8	Malfunction of indoor fan motor
E9	Full water protection
F0	Malfunction of indoor ambient temperature sensor
F1	Malfunction of evaporator temperature sensor
F2	Malfunction of condenser temperature sensor
F3	Malfunction of outdoor ambient temperature sensor
F4	Malfunction of discharge temperature sensor
F5	Malfunction wired controller temperature sensor
C5	Wrong dial switch of capacity
CC	Long-distance monitor or centralized controller has set the shielding function.
EE	Malfunction of outdoor main control memory chip
PF	Malfunction of electric box sensor
H3	Compressor overload protection
H4	Overload protection
H5	IPM protection
H6	Malfunction of DC fan motor
H7	Drive desynchronizing protection
HC	pfc protection
L1	Malfunction of humidity sensor

Lc	Start-up failure
Ld	Compressor phase protection
LF	Power protection
Lp	Models of indoor unit and outdoor unit do not match with each other
U7	Direction changing malfunction of 4-way valve
P0	Drive reset protection
P5	Overcurrent protection
P6	Communication malfunction between main control and drive
P7	Malfunction of drive module sensor
P8	High temperature protection of drive module
P9	Zero-cross protection
PA	AC current protection
PC	Malfunction of drive current
Pd	Sensor connection protection
PE	Temperature excursion protection
PL	Low voltage protection of bus bar
PH	High voltage protection of bus bar
PU	Charging circuit malfunction
PP	Abnormity of input voltage
ee	Malfunction of outdoor drive memory chip

When there is a malfunction during operation, error will be displayed on the temperature displaying zone of LCD. When several malfunctions occur at the same time, these error codes will be displayed circularly.

When there is a malfunction, please turn off the unit and ask the professional for maintenance. For example, E1 means high pressure protection during operation.

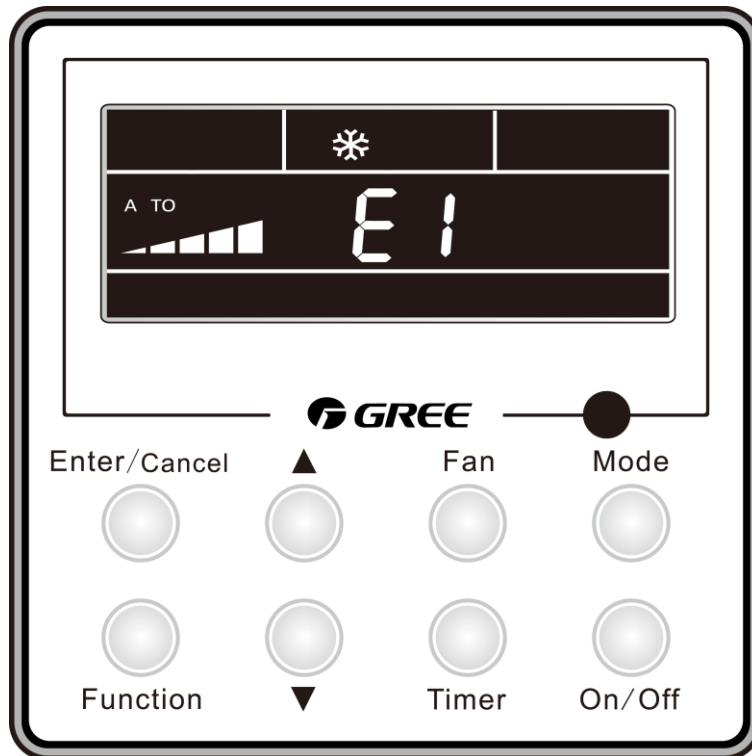

Figure 2-6-1

7 CENTRALIZED CONTROLLER

7.1 Smart Zone Controller

7.1.1 Function

The smart zone controller can directly control up to 16 sets of indoor units in a control network and is available to check the running status of any unit through the LCD, including running mode, timer, fan speed, centralized control and shielding setting etc.

7.1.2 Outline Drawing of Press Buttons



Figure 2-7-1

7.1.3 Functions of Press Buttons

Table 2-7-1 Functions of Press Buttons

No.	Name	Function Description
1	Mode	It is used for the switchover among different modes.
2	Fan	It is used to set the fan speed, high, medium, low or auto.
3	On/Off	It is used to set the on/off status of the indoor unit.
4	▲	① Under the single/centralized control status: It is used to set the running temperature of the indoor unit with max.30°C anmin.16°C; ② Under the timing setting status: It is used to set the timing period with max.24 hours and min.0 hour; ③ Under the clock setting status: it is used to set the hour (max.: 23, min.: 0) and minute (max.: 59, min.: 0) of the clock.
5	▼	
6	Mon 1/9	It is used for the switchover between unit 1 and unit 9; Under the timing or clock setting status, it indicates Monday.
7	Tue 2/10	It is used for the switchover between unit 2 and unit 10; Under the timing or clock setting status, it indicates Tuesday.
8	Wed 3/11	It is used for the switchover between unit 3 and unit 11; Under the timing or clock setting status, it indicates Wednesday.
9	Thu 4/12	It is used for the switchover between unit 4and unit 12; Under the timing or clock setting status, it indicates Thursday.
10	Fri 5/13	It is used for the switchover between unit 5and unit 13; Under the timing or clock setting status, it indicates Friday.
11	Sat 6/14	It is used for the switchover between unit 6 and unit 14; Under the timing or clock setting status, it indicates Saturday.
12	Sun 7/15	It is used for the switchover between unit 7 and unit 15; Under the timing or clock setting status, it indicates Sunday.
13	8/16	It is used for the switchover between unit 8 and unit 16.

14	Timer/Time	It is used to set the timing or on/off time of the selected indoor unit as well as to set the clock of the system.
15	Central	It is used for the switchover between single and centralized control modes.
16	Shield	It is used to deactivate some or all functions of a single or a group the indoor unit(s).
17	All on/off	It is used to start/stop all indoor units.

7.1.4 LCD of the Controller

7.1.4.1 Outline Drawing of the LCD

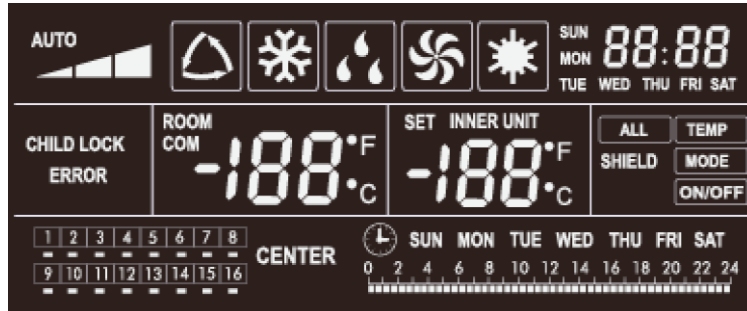

Figure 2-7-2

7.1.4.2 Introduction to Symbols on the LCD



Figure 2-7-3

Table 2-7-2 Introduction to the Symbols on the LCD

No.	Name	Description
1	Fan speed	It displays the fan speed of the indoor unit, high, medium, low and auto.
2	Running mode	It displays the running mode of the indoor unit, auto, cool, dry, fan and heat.
3	System clock	It displays the current time (hour and minute) in 24-hour time system and also the week day.
4	Shield	It displays the shield status, "ALL", "TEMP", "MODE" and 'On/Off'.
5	Weekly timer	It displays the timing period (unit: 0.5 hour) which will circulate every week.
6	Set temperature Indoor unit code	It displays the set temperature, indoor unit code (01-16), and symbols of Celsius and Fahrenheit scale.
7	Control mode	It displays "CENTER" under the centralized control mode and no display under the single control mode.
8	Ambient temperature Serial port	It displays the ambient temperature, serial port as well as symbols of Celsius and Fahrenheit scale.
9	Indoor unit code On/off status	Numbers indicate the indoor unit codes which will be displayed when the corresponding indoor unit is online; "" indicates the on/off status of the indoor unit, its flashing for "on" or else for "off"
10	Error Child lock	It displays the error codes when some error(s) arises and also "CHILD LOCK" when this function is activated.

7.1.4.3 Network Topology

Network Connection of the Smart Zone Controller

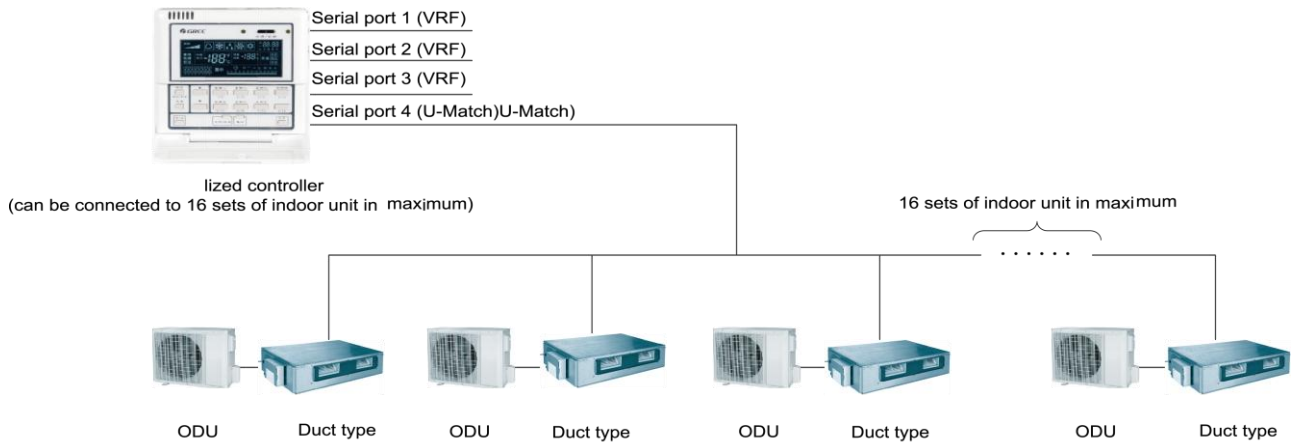

Figure 2-7-4

7.1.4.4 Dimensions

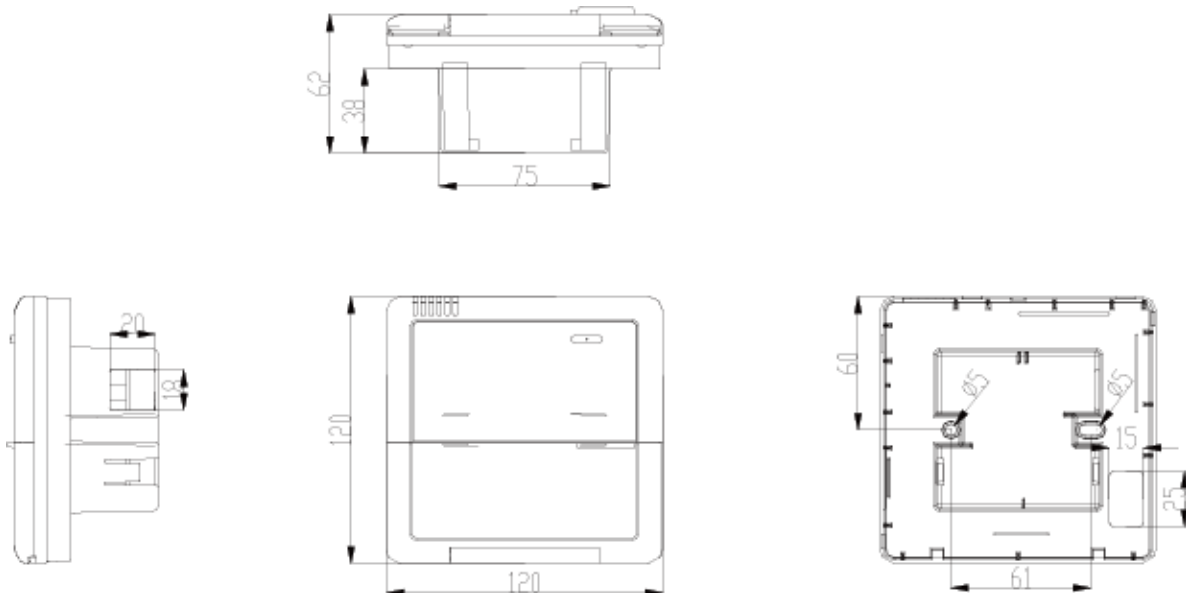

Figure 2-7-5

7.2 Additional Special Functions

7.2.1 Door control function

Door control function is available for this series. In order to achieve this function, please select the door control accessories from Gree.

(1) Interface instructions

- 1) The interface printing is DOOR-C and the type is B2B-XH-B. The wires of door control accessories must be connected to this interface;
- 2) Electrical characteristic: none;
- 3) Working principle: when the card is inserted, this interface is short-circuited; when the card is not inserted, this interface is cut off;

Connect the door control detection port of indoor mainboard with the interface of door control board (CN1 in the following Figure); connect the door control signal to the door control signal input port (X1 and X2 in the following Figure). X1 is AC 220V signal input and X2 is DC +5V to 24V. You can only choose

X1 or X2. Definition of interface is as shown in Figure below:

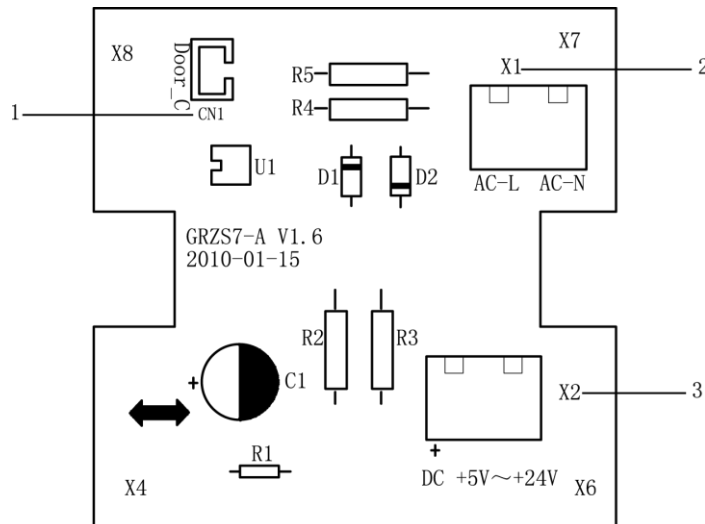



Figure 2-7-6 Illustration of door control port

Table 2-7-3 Door control wiring port

No.	Terminal name	Terminal instruction
1	CN1	CN1 wiring terminal and door control interface of indoor mainboard
2	X1(AC-L, AC-N)	X1(AC-L, AC-N) wiring terminal, connected to door control input signal, rated voltage 220V.
3	X2	X2 wiring terminal, connected to door control input signal

(2) Function instructions:

In order to achieve this function, set it through wired controller and refer to the following operation method. It is defaulted that this function is not activated; if this function is set and door control accessories are connected, the unit will control the ON/OFF of unit according to the card state detected by door control detection board. When the card is not connected, the unit will turn to standby state. If the unit is with wired controller,  icon will be displayed on the wired controller.

If the unit is without wired controller, there will be no display. The unit will control the ON/OFF of unit according to the detected information.

(3) Setting method:

Under off state of the unit, press Function and Timer buttons at the same time for 5s to go to the debugging menu. Press Mode button to adjust to "08" in temperature displaying zone. Timer zone displays setting state and press ▲ or ▼ button to adjust. There are 2 selections:

- 1) Without door control function (LCD displays 00)
- 2) With door control function (LCD displays 01)

Choose the second selection and then press Enter/Cancel button to save and exit setting. Now, door control function is activated. The unit will memorize this setting status. The setting value will be memorized after power failure. The detailed setting is as shown in the Figure below:

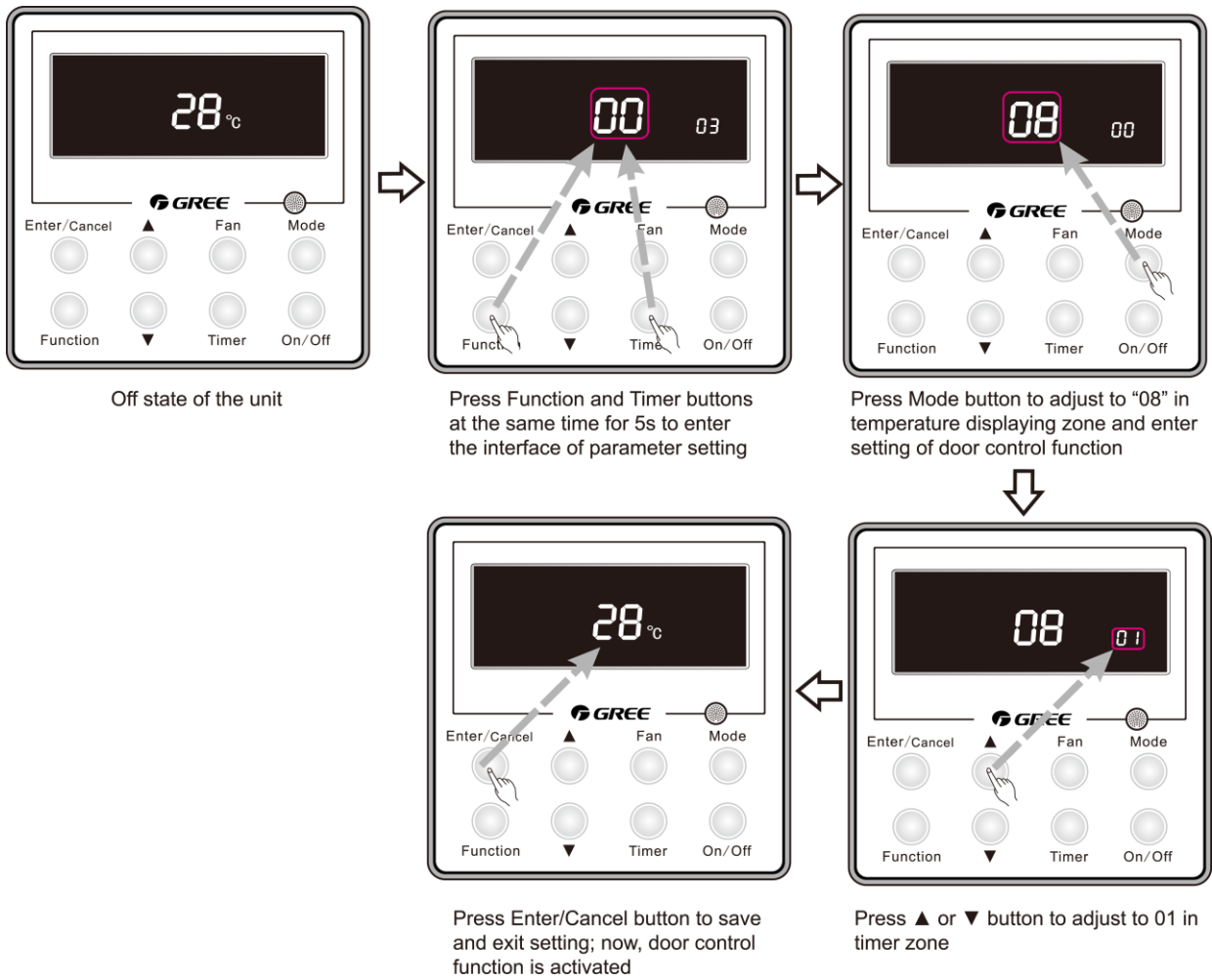

Figure 2-7-7

Note: You can purchase the accessory from Gree. The information is as below:

Name	Product code	Remark
Controller for door control function (MK03)	MC207022	One controller for one unit

7.2.2 Human sensitive function

You can purchase the module of human sensitive function for this series. An interface for this module is reserved on the mainboard of indoor unit.

(1) Interface instruction:

- 1) The printing is CN23 and the interface type is JST B3B-PH-K-S;
- 2) Electrical characteristic: 1-pin: +12V; 2-pin: detection port; 3-pin: GND; current: 150mA;
- 3) Working principle: when the module detects there is nobody in the room, 2-pin and 3-pin are short-circuited and they are low electrical level; when there are somebody in the room, 2-pin output is high electrical level.

(2) Function instructions:

In order to achieve this function, set it through wired controller and refer to the following operation method. It is defaulted that this function is not activated; if this function is set and human sensitive module is connected, the unit will control the ON/OFF of unit according to the signal detected by human sensitive module. When there is nobody in the room and the unit is with wired controller,  icon will be

displayed on the wired controller; if the unit is without wired controller, there will be no display. The unit will control the ON/OFF of unit according to the detected information.

(3) Setting method:

Under off state of the unit, press Function and Timer buttons at the same time for 5s to go to the debugging menu. Press Mode button to adjust to “09” in temperature displaying zone. Timer zone displays setting state and press ▲ or ▼ button to adjust. There are 2 selections:

- 1) Without human sensitive function (LCD displays 00)
- 2) With human sensitive function (LCD displays 01)

Choose the second selection and then press Enter/Cancel button to save and exit setting. Now, human sensitive function is activated. The unit will memorize this setting status. The setting value will be memorized after power failure. The detailed setting is as shown in the Figure below:

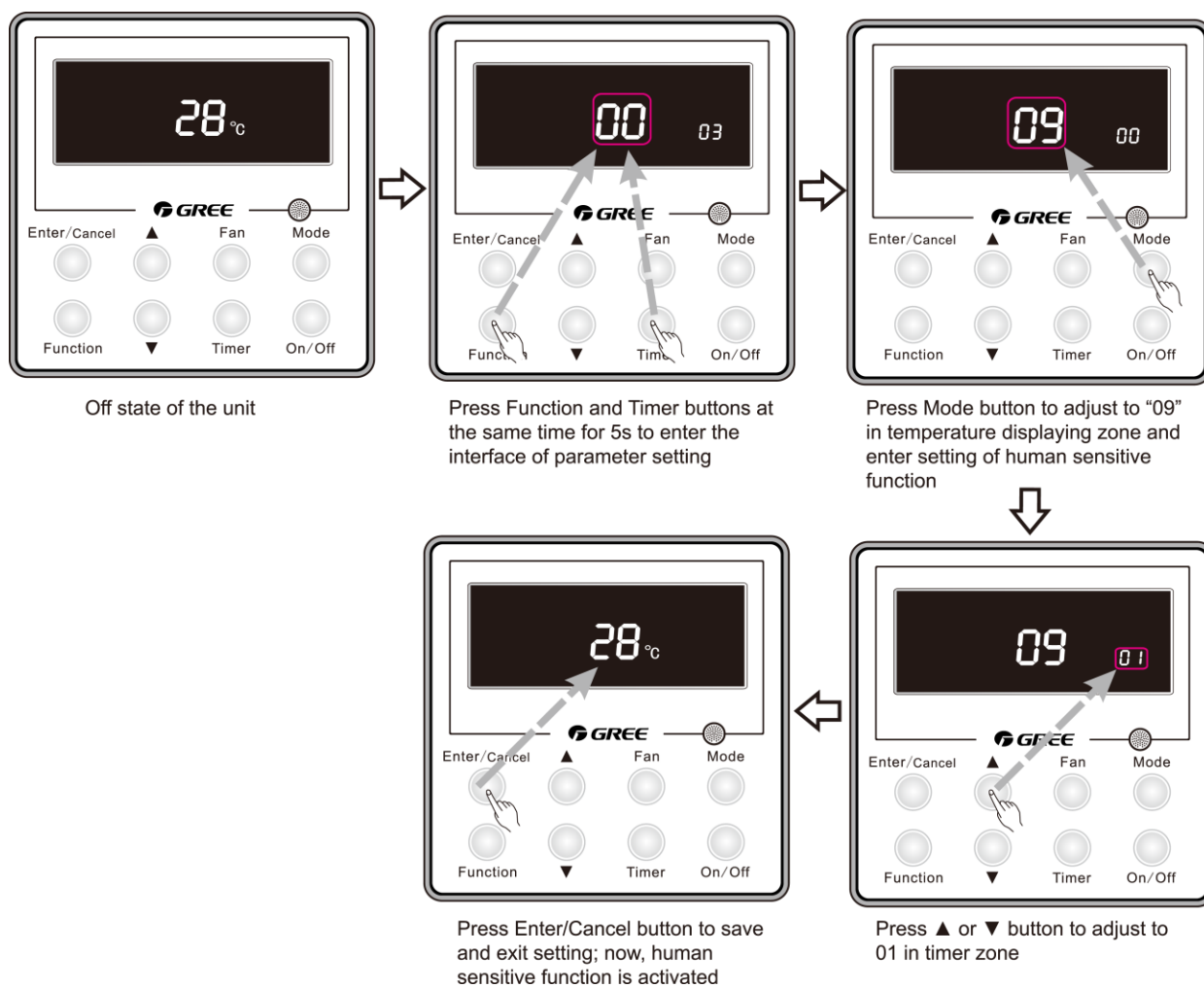

Figure 2-7-8

Note: When door control function and human sensitive function have been set at the same time, it is defaulted that door control function is valid and human sensitive function is invalid.

The user can purchase the human sensitive module by himself. Please pay attention to the following notes:

- ① There is the needle stand interface on the mainboard. The interface model inserted into this needle stand must be PH-3P-K;

- ② The current consumption of module can not exceed the current capacity provided by this interface.

7.2.3 MODBUS interface

The indoor unit of this series has MODBUS interface. If the user needs to connect the unit to the management system of the building, please enquire Gree for the MODBUS protocol.

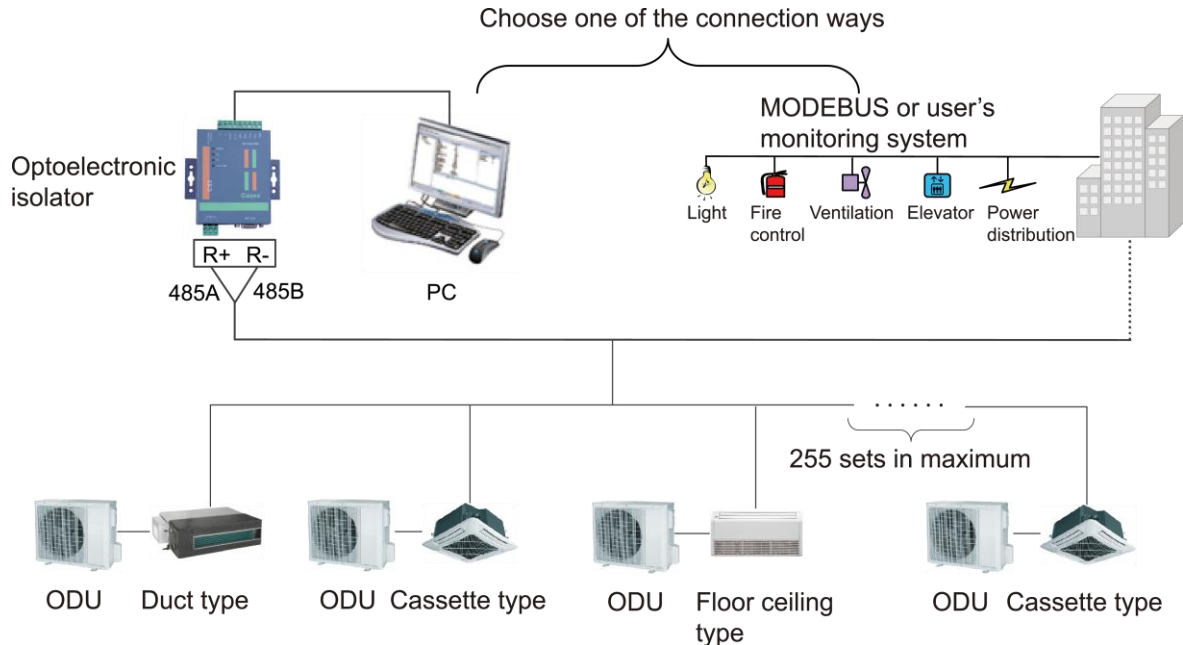

(1) Interface instruction:

- 1) The printing is COM-BMS1 and the interface type is B4B-XH-K3;
- 2) Electrical characteristic: baud rate: 9600bps; standard: RS485;
- 3) Working principle:

The indoor mainboard can send out the unit operation state through this interface and receive logical control information to realize control and monitor of the unit.

(2) Function instructions:

In order to achieve this function, set the address mode and address through wired controller. Please refer to Point 3 for the setting method. You must set the address mode into long-distance control address mode.

The address mode is defaulted to be connecting to centralized controller mode and the defaulted address is 1.

(3) Setting method:

Firstly, set the address mode of wired controller into centralized controller address mode. The setting method is:

Under off state of the unit, press Function and Timer buttons at the same time for 5s to go to the debugging menu. Press Mode button to adjust to "10" in temperature displaying zone. Timer zone displays setting state and press ▲ or ▼ button to adjust. There are 2 selections:

- 1) Centralized controller address mode (LCD displays 00)
- 2) Long-distance control address mode (LCD displays 01)

Choose the second selection and then press Enter/Cancel button to save and exit setting. Now, the address of wired controller is set to match the address of long-distance control. The unit will memorize this setting status. The setting value will be memorized after power failure. The detailed setting is as shown in the Figure below:

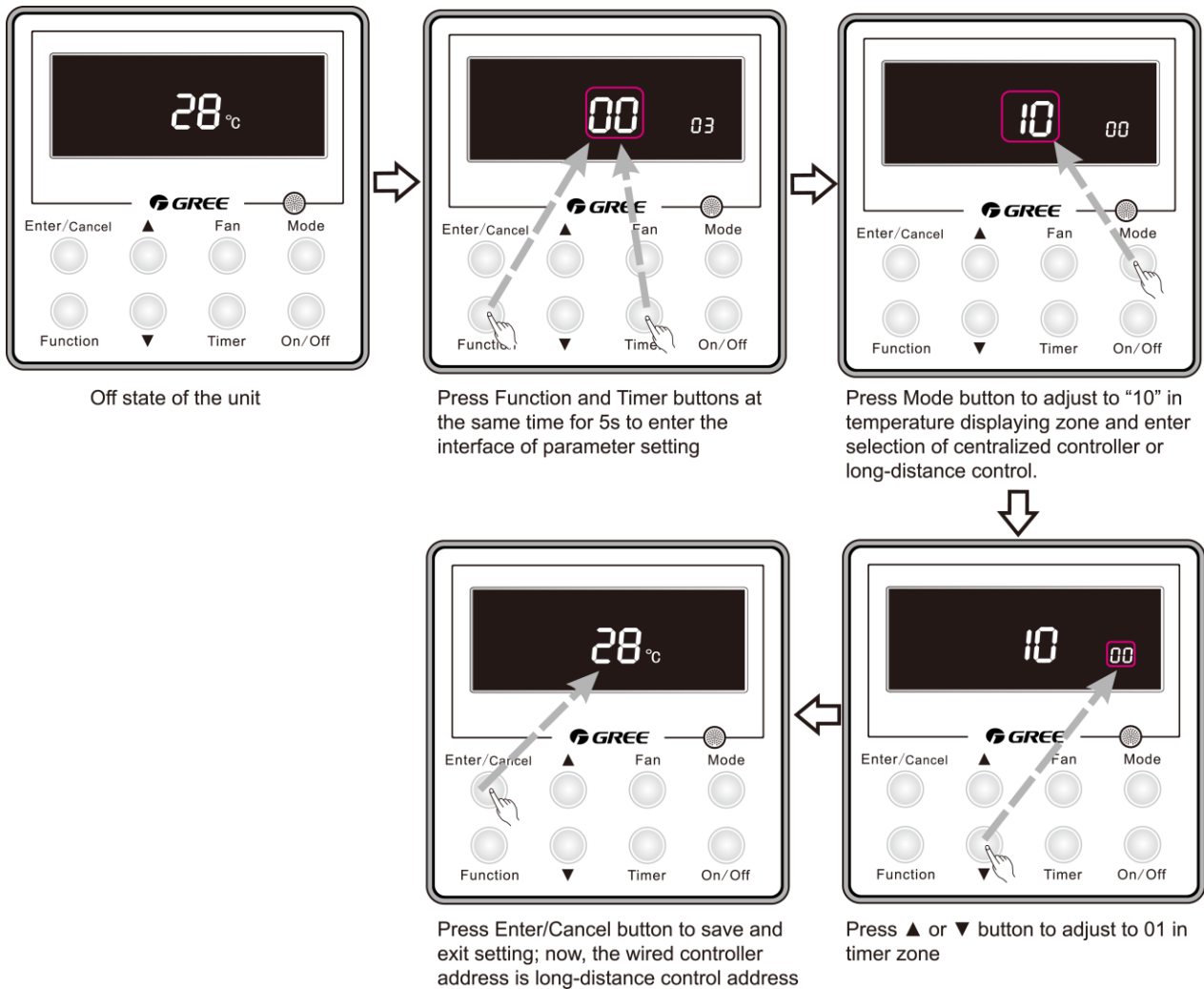

Figure 2-7-10

Address setting of each unit: when the address mode is set to be long-distance control address mode. The address setting value range is 01~255. The setting method is:

Under off state of the unit, press Function and Mode buttons at the same time for 5s to enter setting interface of wired controller address. LCD displays address sequence. Press ▲ or ▼ button to adjust the address sequence and then press Enter/Cancel button to confirm. The setting value will be memorized after power failure. The detailed setting is as shown in the Figure below:

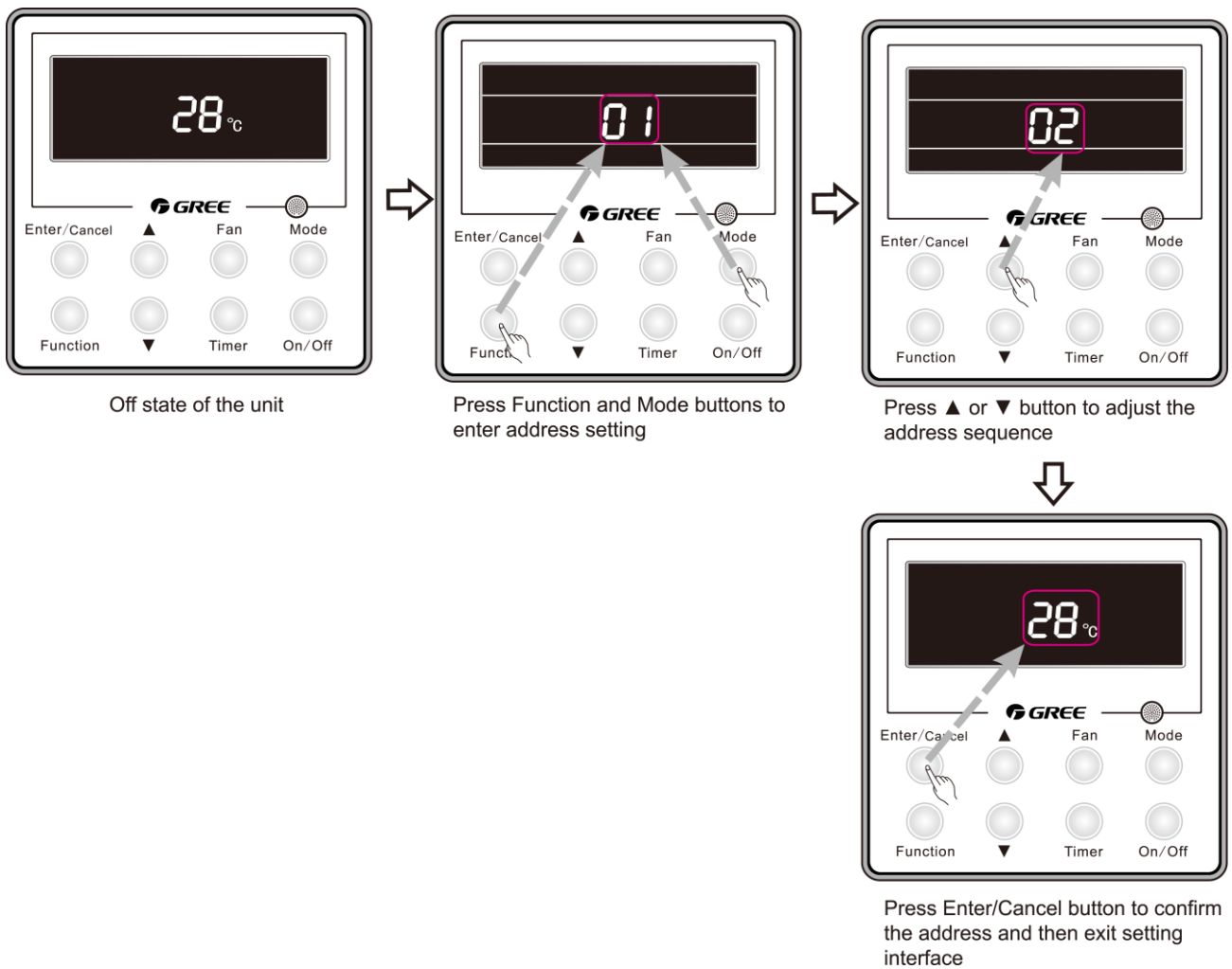

Figure 2-7-11

Note:

- ① In order to realize the MODBUS interface function, the address mode of the unit must be set into long-distance control address mode; you can not set it into centralized control address mode, otherwise, this function can not be realized;
- ② The unit can not be connected to MODBUS and centralized controller at the same time; only one of them can be selected;
- ③ 255 sets of unit in maximum can be connected in the same network; the unit addresses in the same network must be different, otherwise, the unit control will be affected;
- ④ Perform wiring when the unit power is cut off.

7.2.4 Connect to interface of centralized controller

The indoor unit is with the interface of centralized controller. When centralized controller is connected, centralized control of unit can be realized when the wired controller is not connected;

(1) Interface instruction:

- 1) The printing is COM-BMS2, COM-BMS3 and the interface type is B2B-XH-K3;
- 2) Electrical characteristic: none;
- 3) Working principle: centralized control the communication of indoor mainboard and realize the unit control;

(2) Function instructions:

In order to achieve this function, set the address mode and address through wired controller. Please refer to Point 3 for the setting method. The address mode is defaulted to be connecting to centralized controller mode and the defaulted address is 1;

When the centralized controller is connected, centralized control of the unit can be realized to control unit ON/OFF, operation mode, set fan speed/temperature and weekly timer.

(3) Setting method:

Firstly, set the address mode of wired controller into centralized controller address mode. The setting method is:

Under off state of the unit, press Function and Timer buttons at the same time for 5s to go to the debugging menu. Press Mode button to adjust to “10” in temperature displaying zone. Timer zone displays setting state and press ▲ or ▼ button to adjust. There are 2 selections:

- 1) Centralized controller address mode (LCD displays 00)
- 2) Long-distance control address mode (LCD displays 01)

Choose the first selection and then press Enter/Cancel button to save and exit setting. Now, the address of wired controller is set to match the address of centralized controller. The unit will memorize this setting status. The setting value will be memorized after power failure. The detailed setting is as shown in the Figure below:

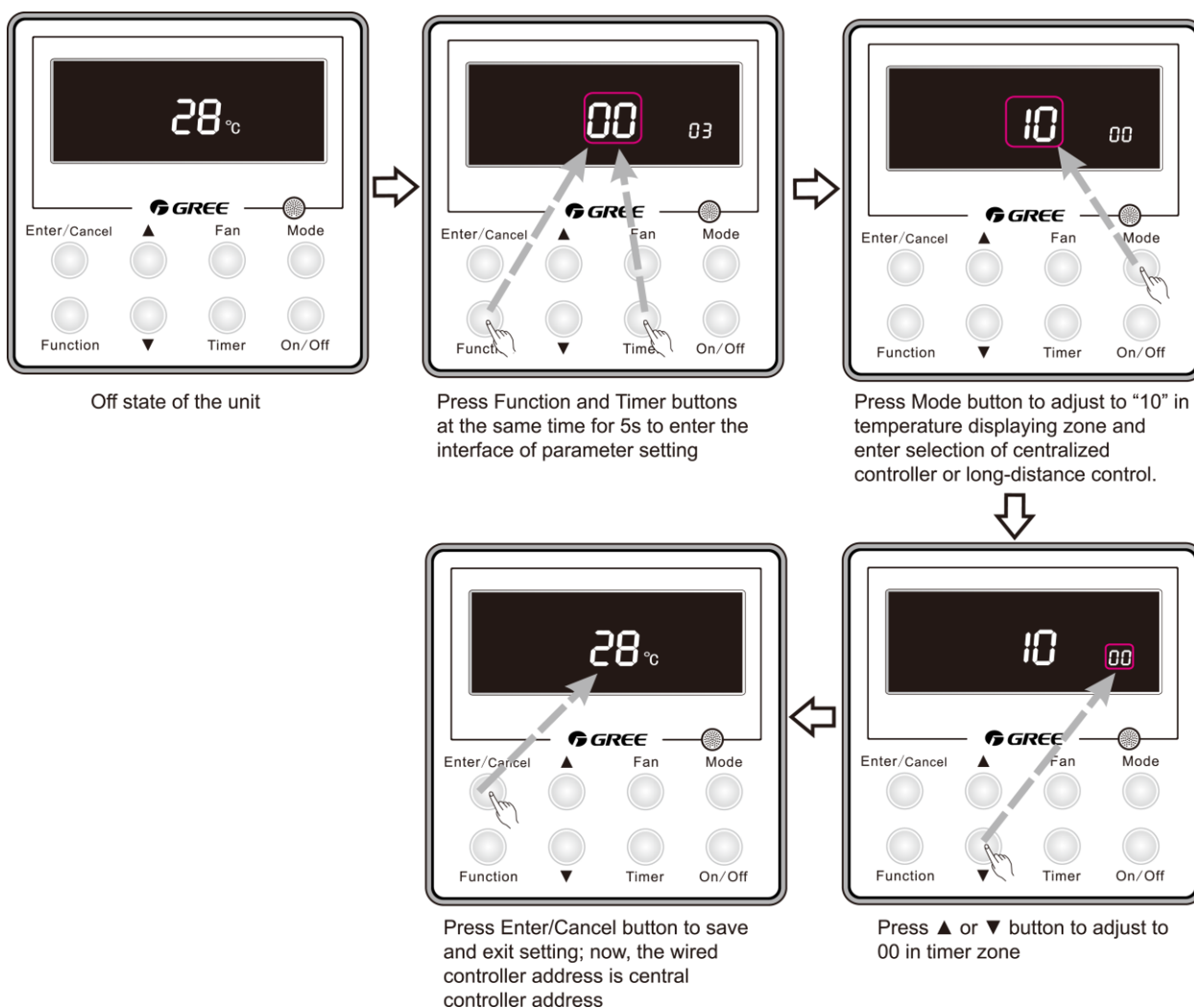

Figure 2-7-12

Address setting of each unit: when the address mode is set to be centralized controller address mode. The address setting value range is 01~16. The setting method is:

Under off state of the unit, press Function and Mode buttons at the same time for 5s to enter setting interface of wired controller address. LCD displays address sequence. Press ▲ or ▼ button to adjust the address sequence and then press Enter/Cancel button to confirm. The setting value will be memorized after power failure. The detailed setting is as shown in the Figure below:

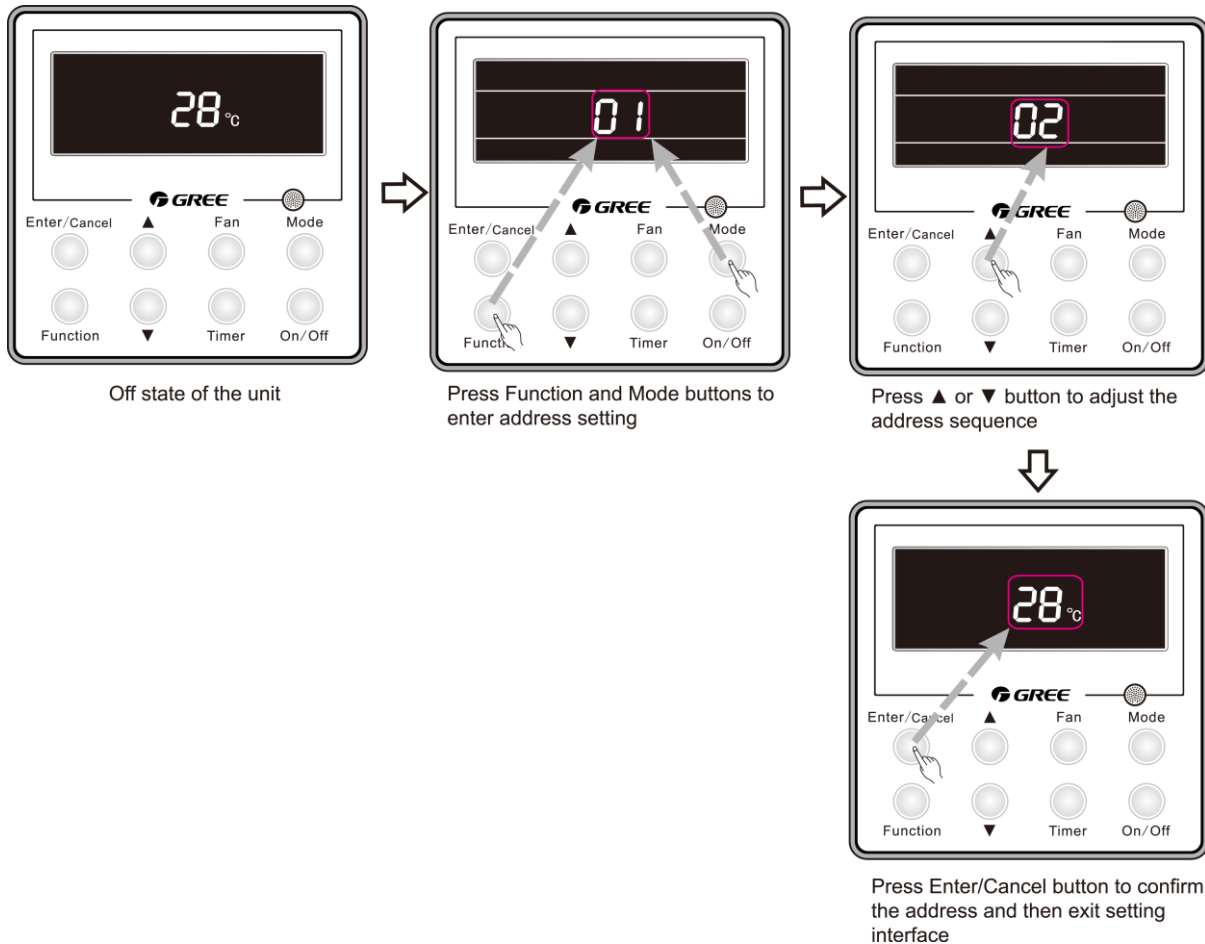

Figure 2-7-13

When the address is set, the wired controller can be removed and connect the centralized controller to the indoor mainboard. Then connect the required units to realize centralized control of these units;

Note:

- ① When centralized controller is to be connected, set the address mode into centralized controller address mode through wired controller. Long-distance control address mode can not be set;
- ② The unit addresses in the same network must be different, otherwise, communication malfunction will occur and the unit can not work normally;
- ③ When centralized controller is to be connected, the unit address range is 1-16. Only 16 sets of unit in maximum can be connected
- ④ The code and model of wired controller is as below:

Name	Product code	Remark
Centralized controller CE50-24/E	MC207025	Only 16 sets of unit in maximum can be connected to this controller

7.2.5 Light board control

Light board interface is reserved on the mainboard of duct type unit. You can purchase Gree light board to realize control of the unit. When wired control is also connected, you can realize control of the unit through light board and wired controller.

Light board information:

Name	Product code	Remark
Receiving board Z6L	30260000001	Only for duct type unit

There are two buttons on the light board to control ON/OFF of cooling and heating. There are also other indicators and nixie tube display.

Cooling: set temperature 26°, low fan speed; heating: set temperature 20°, low fan speed

Function instructions: under OFF state, pressing Cool/Heat button can turn on cooling/heating mode. Under unit ON state, pressing Cool/Heat button can turn off the unit. When the unit is in cooling/heating mode, pressing any button can turn off the unit.

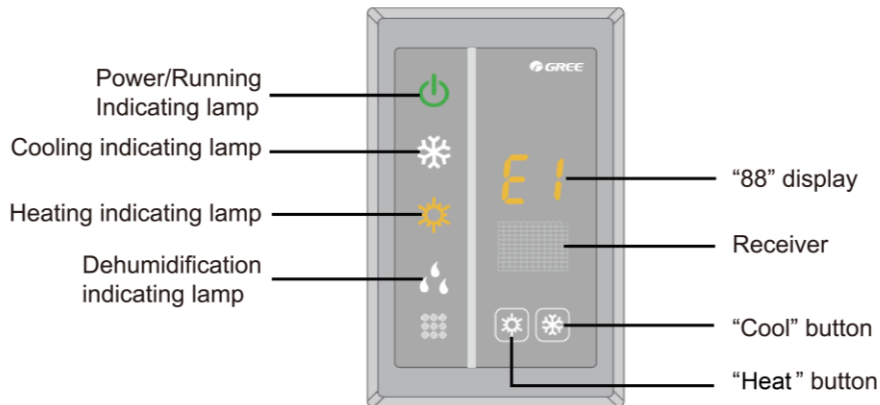

Figure 2-7-14

7.2.6 Malfunction output of relay

There is malfunction outlet signal on the mainboard of indoor unit; when the unit occurs unrecovered malfunction, this signal will be output.

(1) Interface instruction:

- 1) Printing: X5, ERROR
- 2) Electrical characteristic OF malfunction indicator or electric bell: 220V~AC, power ≤ 10W
- 3) Working principle: when the unit occurs unrecovered malfunction, the relay will suck and 220V AC signal will be output.

(2) Function instructions:

When the user needs centralized control over several units, malfunction signals can be connected to control room through this malfunction output interface. The user can indicate the unit malfunction through malfunction DC indicator or electric bell, so the management people can go to check the malfunction unit directly.

If dry contact detection of unit malfunction is needed, please connect this interface into the monitoring system. When the closed signal is detected when malfunction occurs, this signal can be seen in monitoring system.

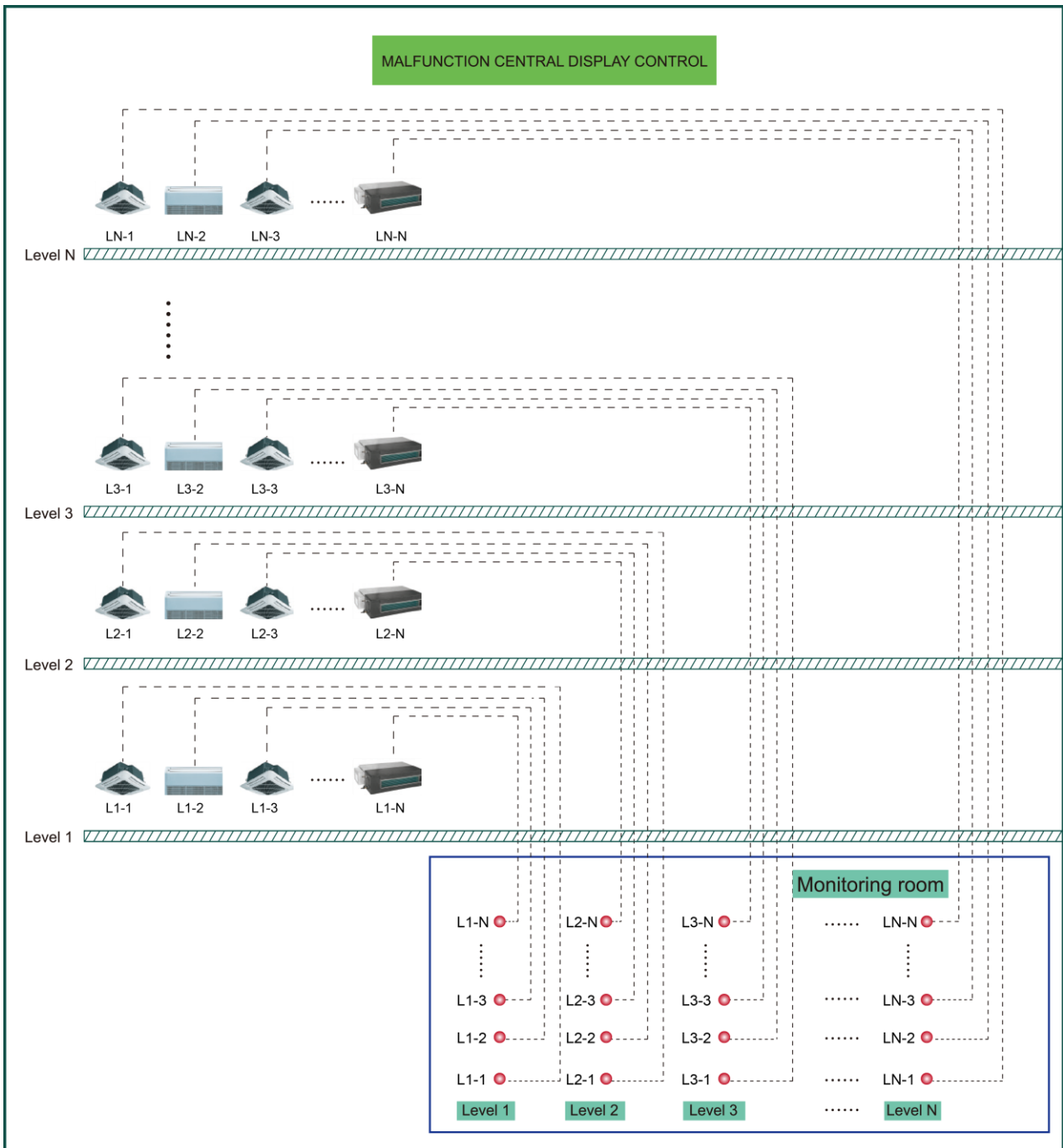

Figure 2-7-15 Malfunction output

(3) Setting method:

Do not need to set this function

Notes:

- ① The interface voltage should be 220V AC intense current;
- ② If malfunction light is connected, please make sure its power is not too big (it should be within 10W), otherwise, the relay on mainboard will be burnt.

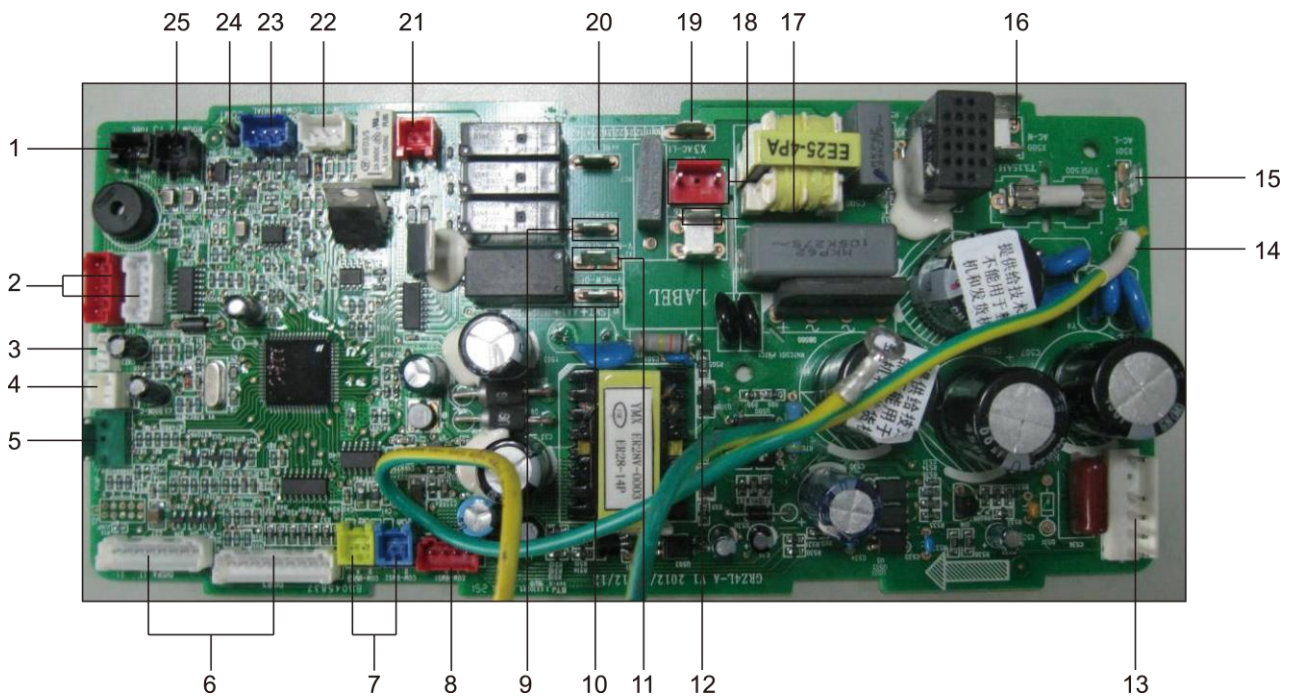

Figure 2-7-15

Table 2-7-4 Corresponding interfaces of mainboard

No.	Interface
1	Evaporator temperature sensor
2	Swing motor
3	Human sensitive
4	Door control
5	Full water detection
6	Interface of light board
7	Communication port of centralized controller
8	MOUSBUS interface
9	Interface of annunciator live wire
10	ON interface of fresh air valve
11	OFF interface of fresh air valve
12	Interface of annunciator neutral wire
13	Interface of DC motor
14	Mainboard grounding wire
15	Power live wire
16	Power neutral wire
17	Neutral wire of fresh air valve
18	Water pump interface
19	Live wire of fresh air valve
20	Interface of anion generator
21	Interface of auxiliary heating board
22	Interface of outdoor unit
23	Interface of wired controller
24	Monitor interface
25	Ambient temperature sensor

7.2.7 Reserved fresh air valve interface for duct type unit

For the reserved connection way of air valve performer, connect it to F, C, O of wiring board according to the wiring diagram. Connect the public port of air valve to F, connect CLOSE to C and connect OPEN to O.

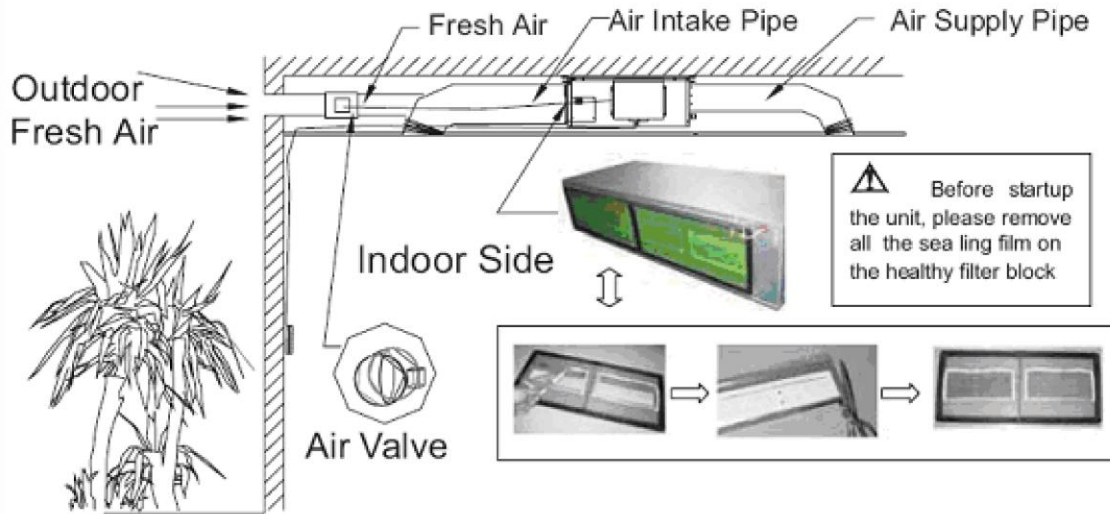

Figure 2-7-16

7.2.8 Interface of anion generator

For the cold plasma anion generator, connect the red line to HEALTH (X4) and the blue line to N2(X6) according to the principle circuit. The detector of cold plasma anion generator should be places at the air return. The distance between two detectors should be $10\text{mm} \leq L \leq 25\text{mm}$.

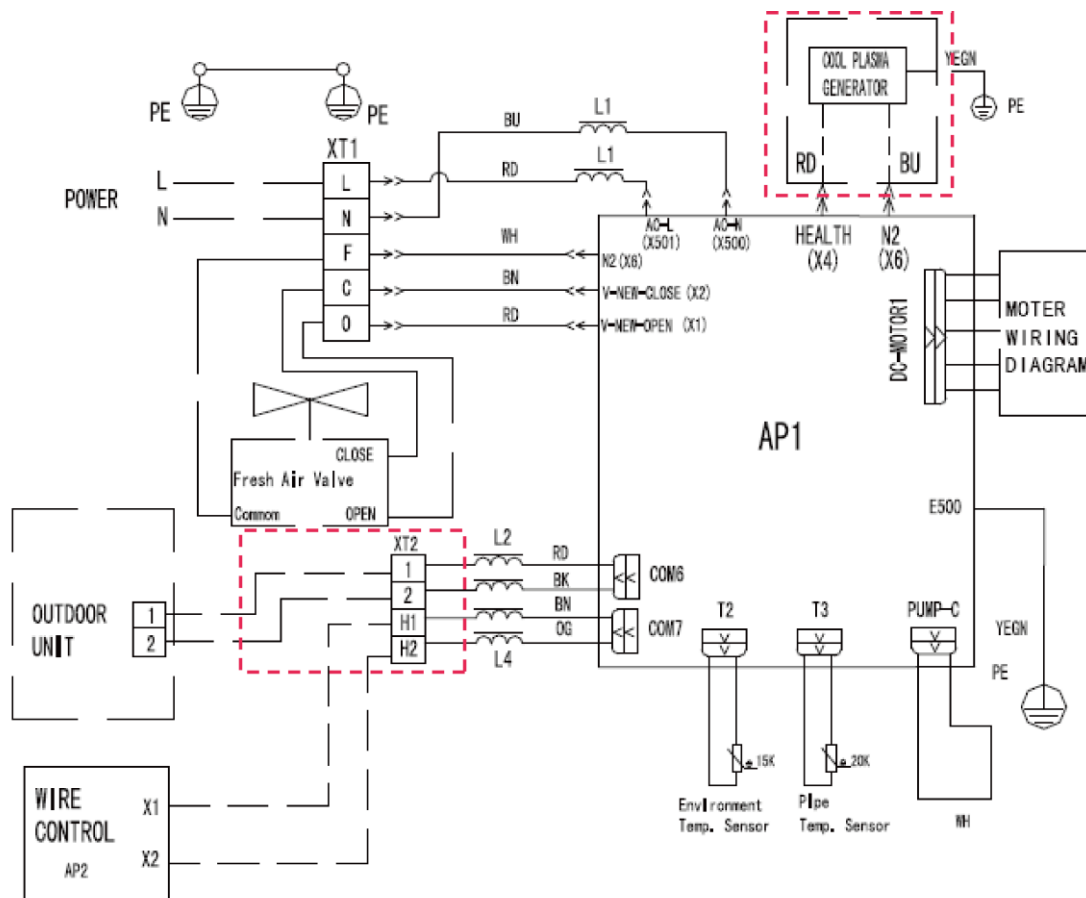

Figure 2-7-17

7.2.9 Chassis electric heating belt of outdoor unit is optional

When outdoor ambient temperature is very low, electric heating belt can be equipped on the chassis to prevent freezing of the chassis.

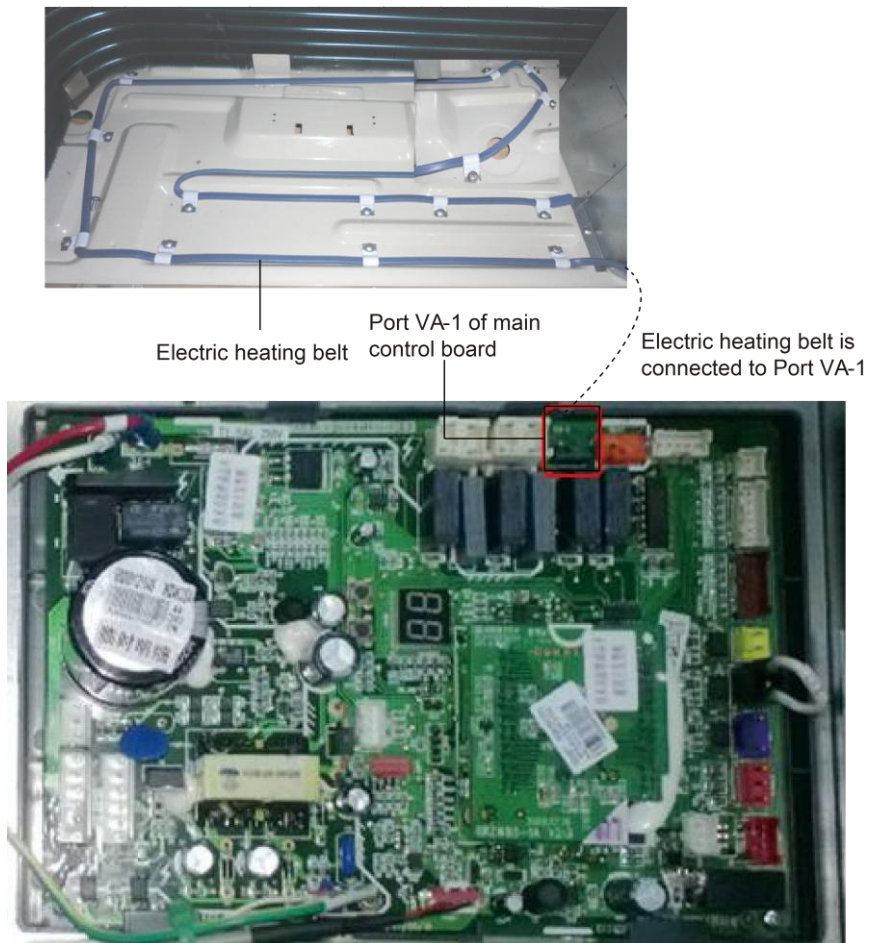

Figure 2-7-18

INSTALLATION

INSTALLATION

1 INDOOR UNIT INSTALLATION

1.1 Installation of Duct Type

1.1.1 Before Installation

After receiving the machine, please check for any transport damage. If finding any surface or internal damage, please immediately report to the transport company or equipment company in writing.

After receiving the machine, please check the unit and accessories in reference to the packing list. Ensure that the model is correct and the machine is in good condition. Please also check if the specification and quantity of accessory parts are correct.

Determine the correct handling route and methods, thus to avoid damaging the unit or causing possible hazard. For the sake of protection and safety, it is suggested to move the unit with the packaging box. Even though it is not permitted to do like this under special occasions, do not remove the packaging box, thus to avoid loosening or falling during handling.

Confirm if the installing foundation is solid. When this unit is to be installed on the metal section of the building, make sure that the electrical insulation must comply with applicable standards.

Ensure that the place of installation is far from the area where the inflammable or explosive substances are stored, thus to avoid possible explosion or fire due to leakage.

1.1.2 Installation Site

Ensure the top hanging piece has strong strength to withstand the weight of the unit.

The drainage pipe has convenient flow of water.

There is no obstacle blocking the return air inlet and exhaust outlet, so as to ensure sound air circulation.

The installation spaces required by the drawing must be ensured, so as to provide enough space for the service and maintenance.

The installation site must be far away from heat source, leakage of inflammable gas or smoke.

The indoor unit is of ceiling mount (indoor unit is hidden inside the ceiling).

The indoor and outdoor units, the power cable and the connecting electrical lines must be at least 1 meter from any TV set or radio. This is to avoid image interference or noise of the TV set or radio. (Even if the distance is 1 meter, noise can also exist if there is strong electric wave.)

1.1.3 Caution for Installation

Generally, the unit is installed indoor on ceiling. For ceiling mounting, ensure that the hangers on ceiling have adequate strength to support the weight of the unit.

To meet the noise and vibration requirements, the unit shall be installed by using rubber pad (thickness $\geq 20\text{mm}$) and rubber connector.

Insert a M10 expansion bolt into the hole. Drive a nail into the bolt. Refer to the profile dimensions drawing of the indoor unit for the distance between the holes. Refer to Figure 3-1-1 for the installation of the expansion bolt.

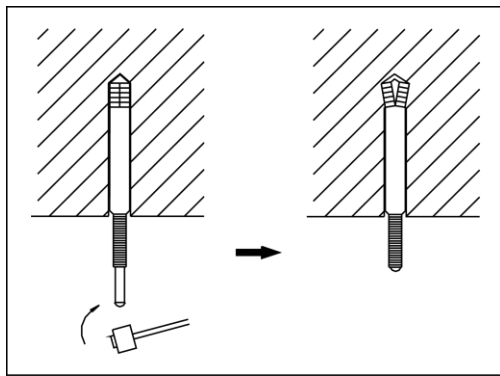

Figure 3-1-1

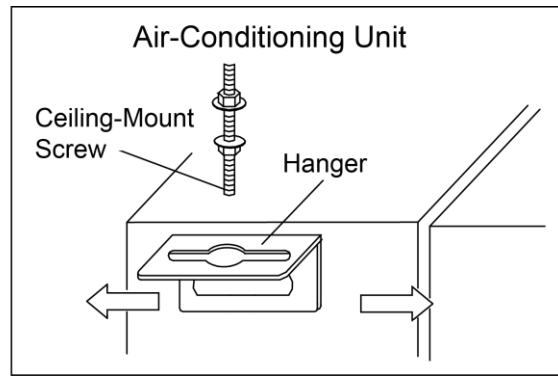

Figure 3-1-2

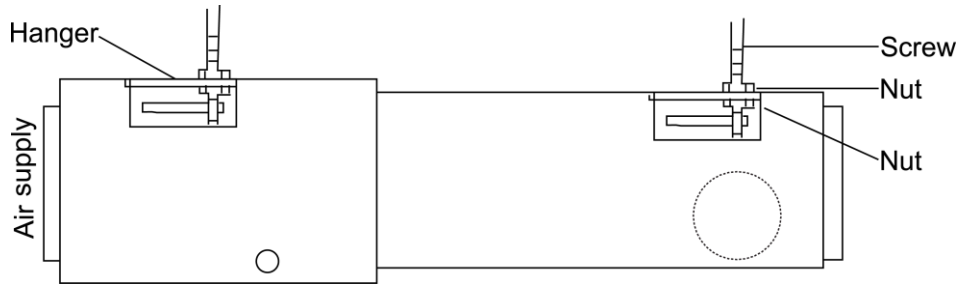

Figure 3-1-3

Install the hanger onto the indoor unit as Figure 3-1-2 and Figure 3-1-3 shows.
Install the indoor unit at the ceiling as Figure Figure 3-1-4 shows.

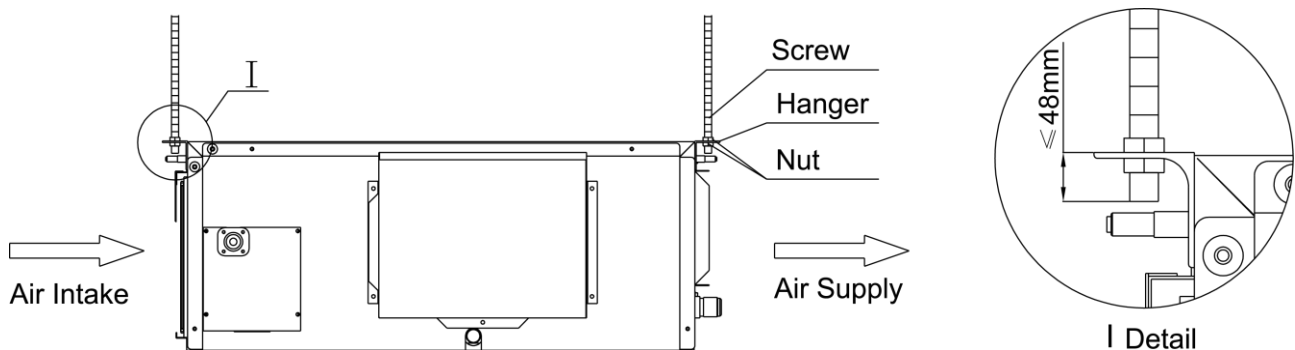

Figure 3-1-4

Precautions for unfavorable installation:

The preparation of all pipes (connecting pipes and drainage pipes) and cables (connecting lines of wire controller, indoor unit and outdoor unit) must be ready before the installation, so as to achieve smooth installation.

Drill an opening on the ceiling. Maybe it is required to support the ceiling to ensure the evenness of it and avoid the vibration of it. Consult with the user or a construction company for details.

In case the strength of ceiling is not enough, use angle iron sections to set up a beam support. Place the unit at the beam and fix it.

Level inspection of the indoor unit

After the indoor unit is installed, it is required to check the level of the whole unit. The unit must be placed horizontally, but the condensate pipe shall be installed obliquely, so as to facilitate the drainage of condensate.

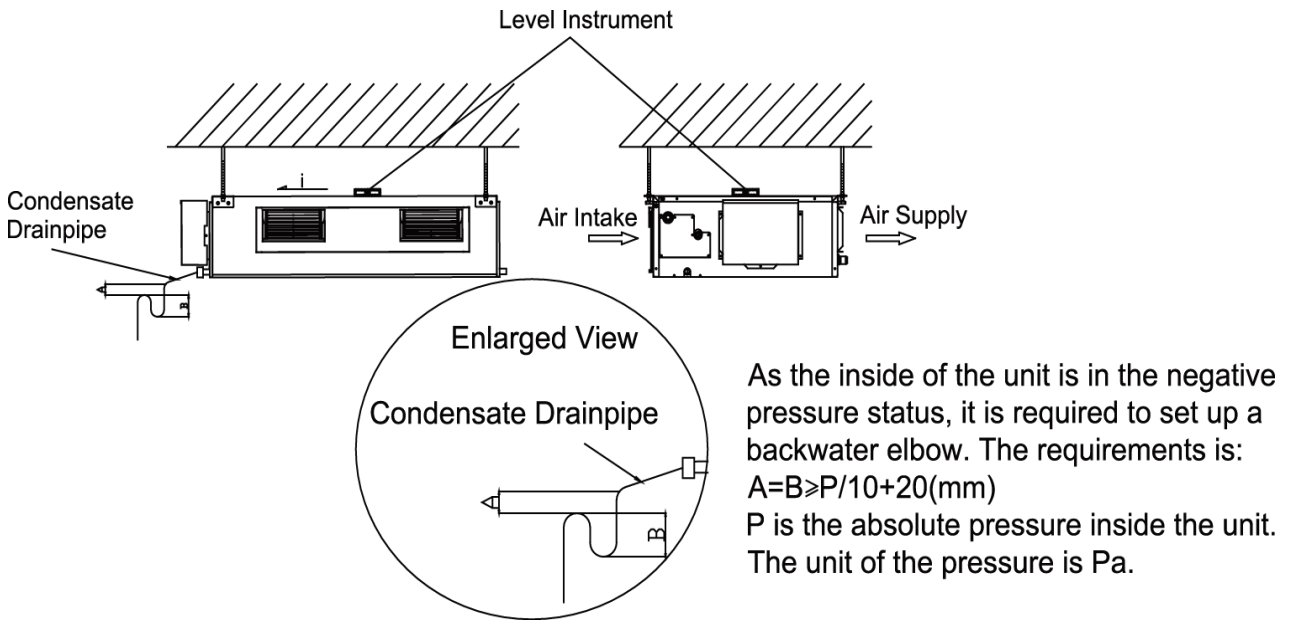
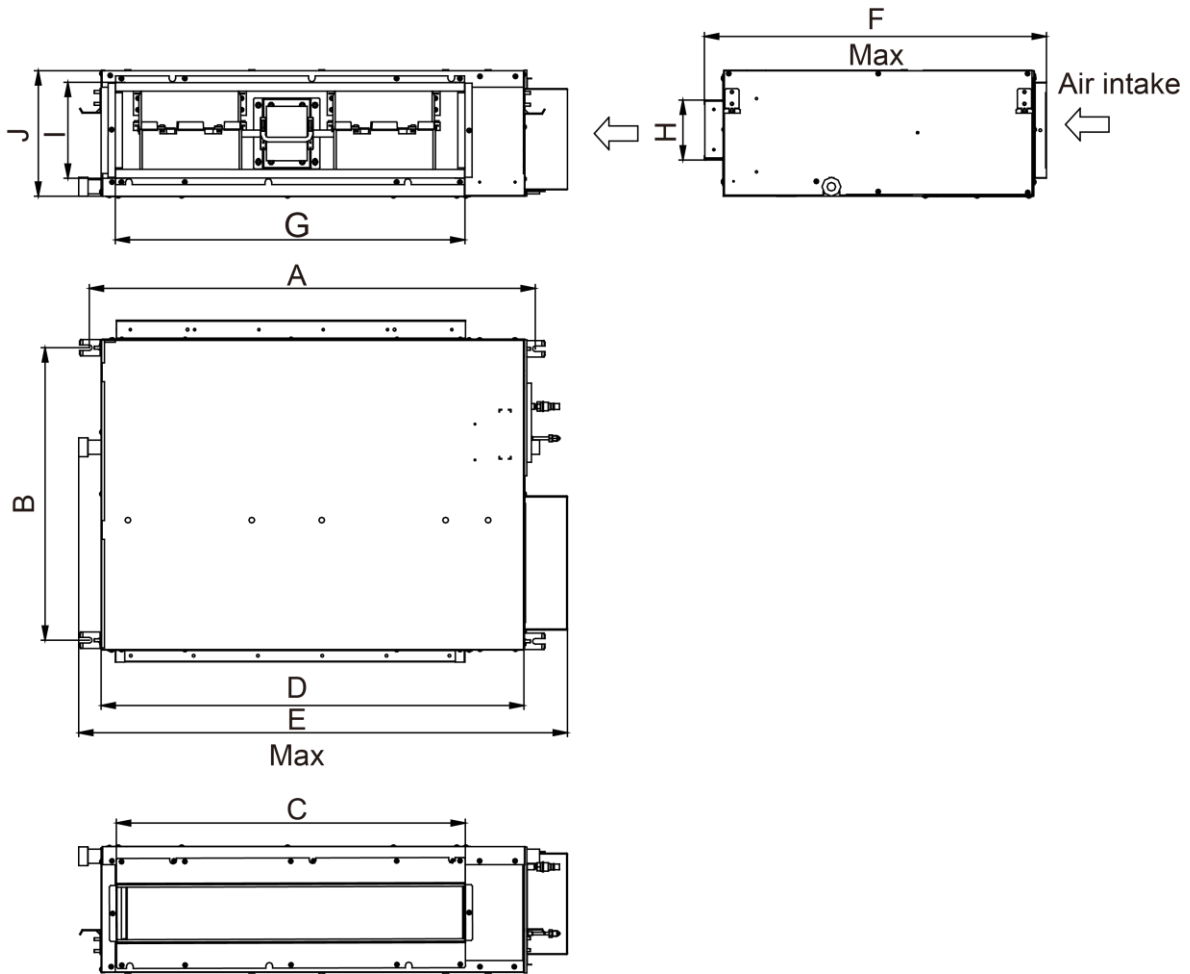

Figure 3-1-5

1.1.4 Dimension Data

For the units: 09~18k, 48k, 60k



For the units: 24~42k

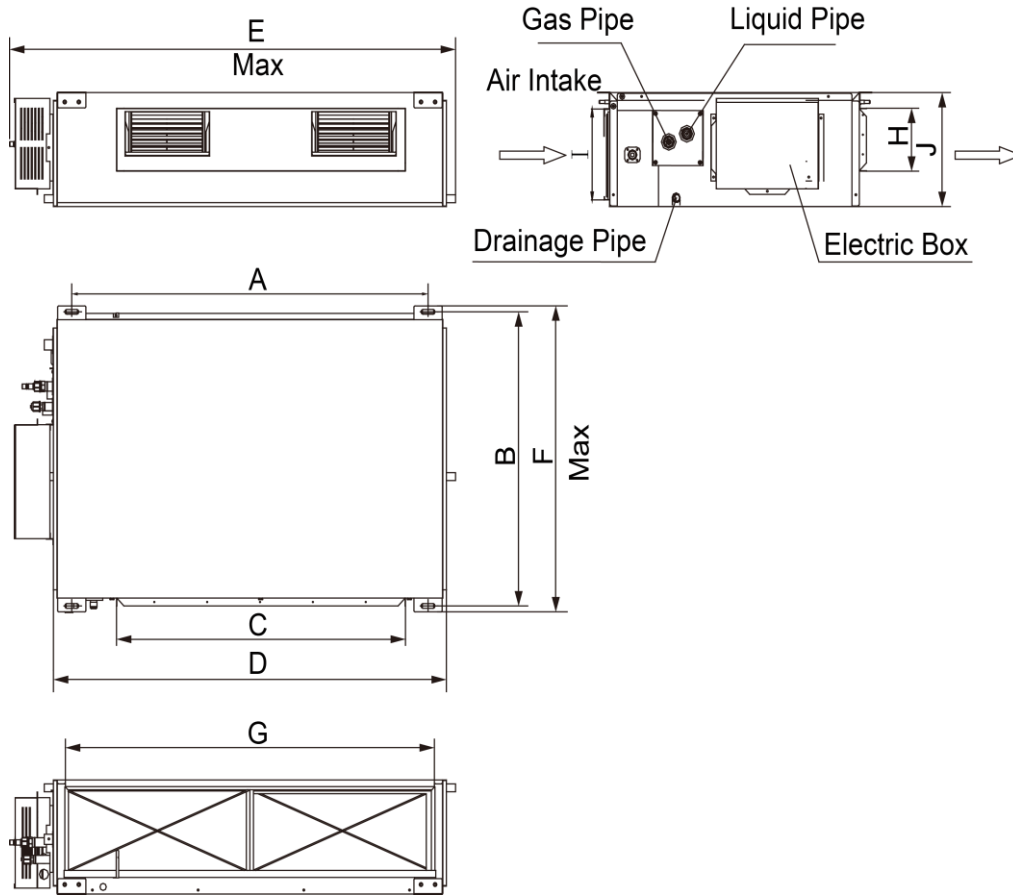

Figure 3-1-6

Table 3-1-1

Model \ Item	A	B	C	D	E	F	G	H	I	J
GFH09K3FI	840	561	635	790	925	665	738	125	203	250
GFH12K3FI	945	618	738	892	1035	720	738	125	203	265
GFH18K3FI										
GFH24K3FI	1101	517	820	159	1280	560	1002	160	235	270
GFH30K3FI										
GFH36K3FI	1011	748	820	1115	1225	775	919	160	231	290
GFH42K3FI										
GFH48K3FI	1177	646	852	1150	1340	750	953	190	316	350
GFH60K3FI										

Table 3-1-2 Installation Accessories List for Duct-type Indoor Unit

Name & Shape	QTY	Notes
Installation and Operating Instructions	1	
Insulation materials for gas pipe	1	Used for gas pipe connector on indoor unit
Insulation materials for liquid pipe	1	Used for liquid pipe connector on indoor unit
Insulation materials for drainage pipe	2	Used for wrapping the condensate pipe and rubber plug.
Nut M8 with gasket	8	Use for fixing the hanger hook
	4	4 sets, used for ceiling mounting of the indoor unit
Nut and spring gasket	4	
Hook	4	Used for ceiling mounting of the indoor unit
Strap	4 or 8 pcs	4 pcs for 18kBtu/h unit and 8 pcs for others
Wired controller	1	
Remote controller	1	
Battery	2	
Flexibile pipe	0.2 or 4 pcs	0 pc for 18kBtu/h unit; 2 pcs for 22.5, 27kBtu/h unit; and 4 pcs for 36-45kBtu/h unit
Power cord	1 – 2 pcs	2 pcs for 36-45kBtu/h unit and 1 pc for others
Connection wire		

1.1.5 Installation Clearance Data

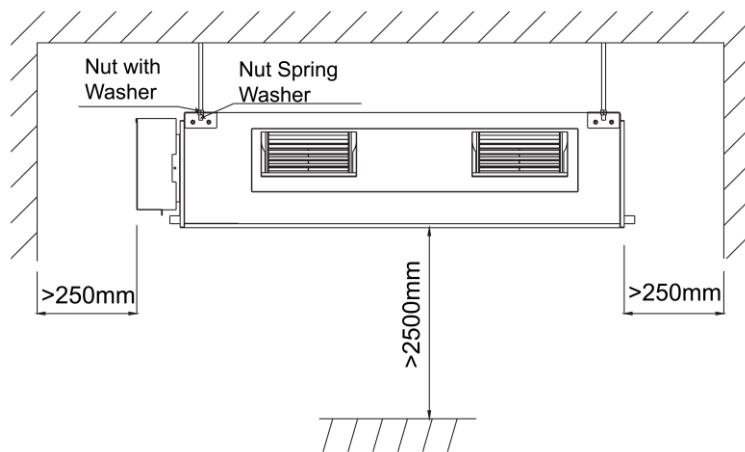

Figure 3-1-7

Warning: The height of installation for the indoor unit should be 2.5m above.

1.1.6 Drain Piping Work

Installation of Drainage Pipeline:

 CAUTION!
Install the drain hose in accordance with the instructions in this installation manual and keep the area warm enough to prevent condensation. Problems with the piping may lead to water leaks.

- (1) Install the drain hose with downward gradient (1/50 to 1/100) and no risers or traps are used for the hose. (Figure 3-1-8)
- (2) Be sure there is no crack or leak on the drain hose to avoid the formation of air pocket. (Figure 3-1-8)
- (3) When the hose is long, install supporters. (Figure 3-1-9)
- (4) Always use the drain hose which has been insulated properly.

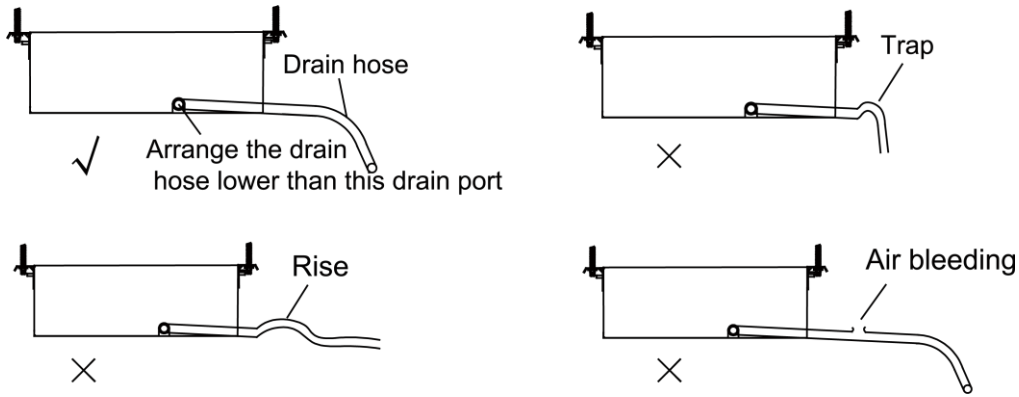

Figure 3-1-8

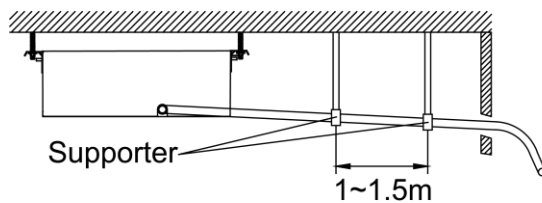

Figure 3-1-9

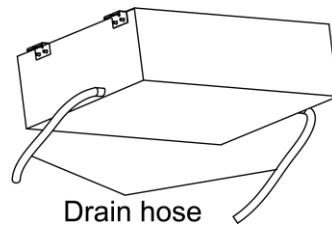
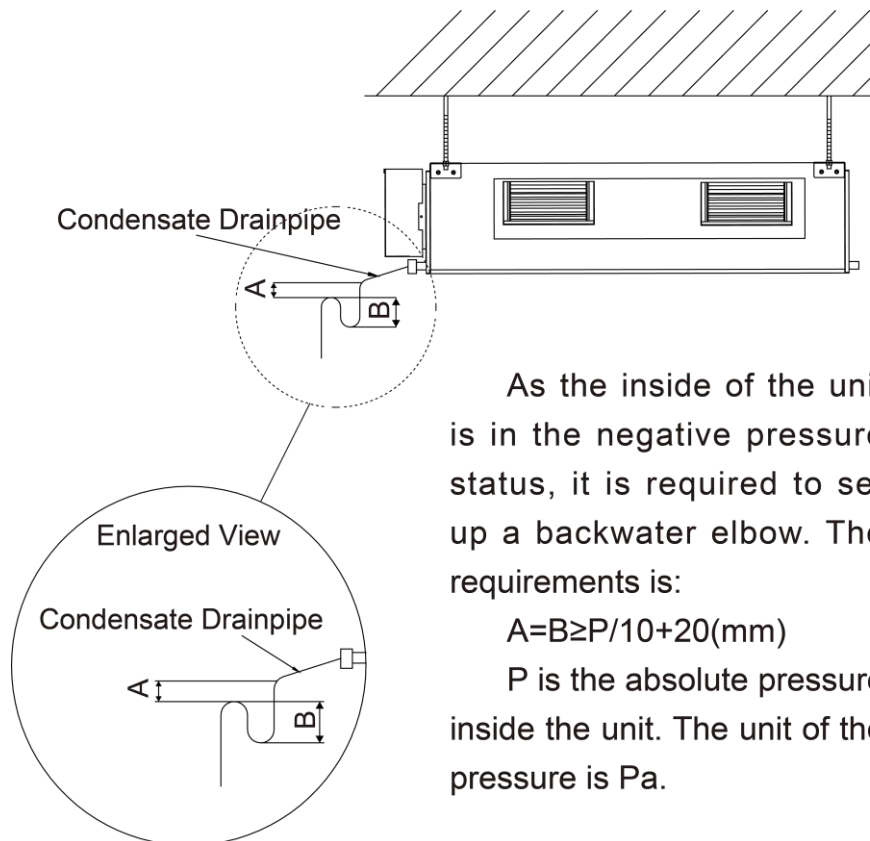

Figure 3-1-10



As the inside of the unit is in the negative pressure status, it is required to set up a backwater elbow. The requirements is:

$$A=B \geq P/10+20(\text{mm})$$

P is the absolute pressure inside the unit. The unit of the pressure is Pa.

Figure 3-1-11

- (5) Use a suitable drain hose, and see Table 3-2-4 for its size.
- (6) There is a drain port on both the left and right sides. Select the drain port to match the local conditions. (Figure 3-1-10)
- (7) When the unit is shipped from the factory, the drain port is defaulted to be the one on the left side (electric box side); the port on right side has been plugged.
- (8) When using the drain port on the right side of the unit, reinstall the drain cap to the left side drain port. (Figure 3-1-12)

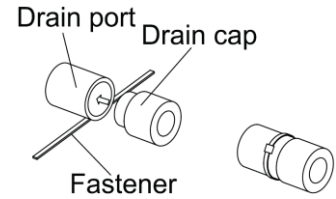

Figure 3-1-12

CAUTION!

Always check that the drain cap is installed to the unused drain port and is fastened with the nylon fastener. If the drain cap is not installed, or is not sufficiently fastened by the nylon fastener, water may drip during the cooling operation.

- (9) Be sure to insulate where the drain port and the drain hose is connected. (Figure 3-1-13)
- (10) The unused drain port also should be insulated properly. (Figure 3-1-14)

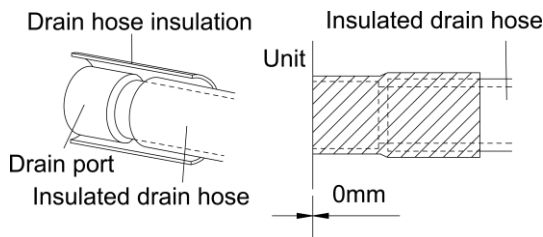

Figure 3-1-13

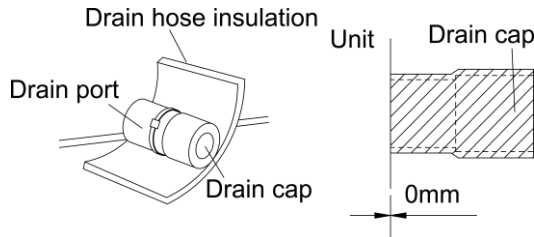

Figure 3-1-14

- (11) There is adhesive on one side of the insulation so that after removing the protective paper over it the insulation can be directly attached to the drain hose.
- (12) Considerations for the unit with the condensate pump:
 - 1) For the unit with the condensate pump, only one drain port at the side close to the electric box is prepared and only through it the drain hose can be connected.
 - 2) See table 3 for the size of the drain port of the unit with the condensate pump, which is different from that of the unit without the condensate pump.
 - 3) For the unit with the condensate pump, two drain ports at the bottom are defaulted to be factory plugged with drain caps. After the installation of the drain hose, these two drain ports also need to be insulated properly with the same way aforementioned.
 - 4) The drain hose for the unit with the condensate pump should be arranged as shown in the figure below.

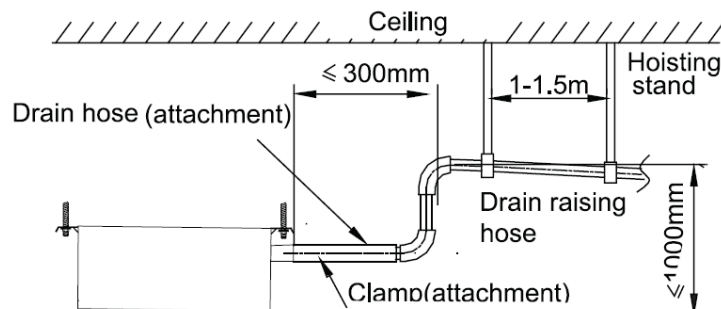

Figure 3-1-15

- a) The vertical height of the drain hose should be 75mm or less so that it is unnecessary for the drain port to withstand additional force.

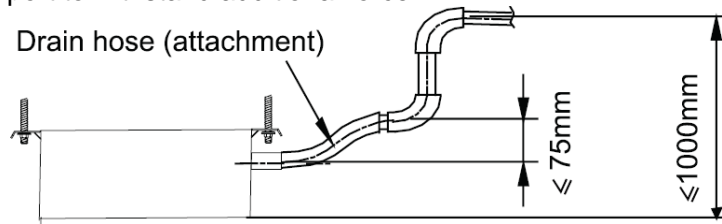

Figure 3-1-16

- b) When multiple drain hoses are used, their installation should be performed as shown in the figure below.

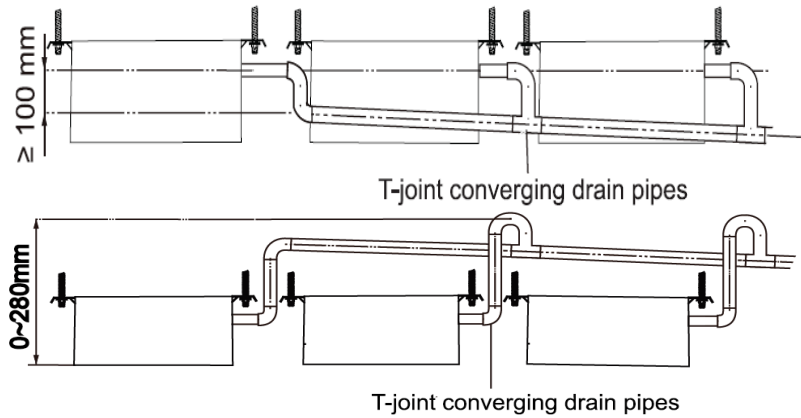

Figure 3-1-17

1.1.7 Installation of air duct

Dimensions of the Supply Air Outlet/Return Air Inlet

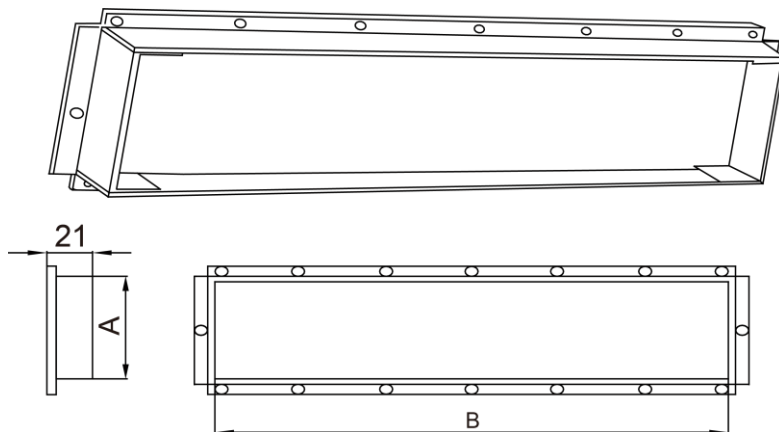

Figure 3-1-18 Supply Air Outlet

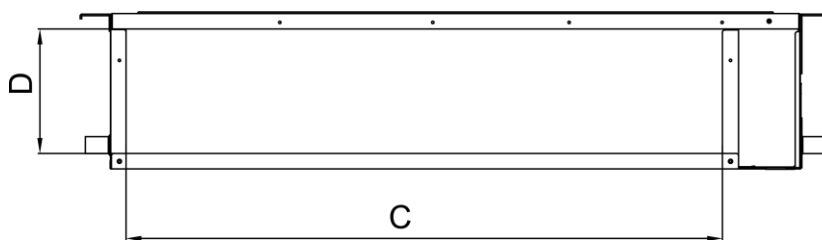

Figure 3-1-19 Return Air Inlet

Table 3-1-3

Model	Item	Supply Air Outlet		Return Air Inlet	
		A	B	C	D
GFH09K3FI		133	633	710	166
GFH12K3FI		123	736	710	166
GFH18K3FI		123	736	710	166
GFH24K3FI		158	818	994	195
GFH30K3FI		158	818	994	195
GFH36K3FI		158	818	1000	206
GFH42K3FI		158	818	1000	206
GFH48K3FI		190	850	940	286
GFH60K3FI		190	850	940	286

1.1.8 Installation of the Supply Air Duct

(1) Installation of the Rectangular Duct.

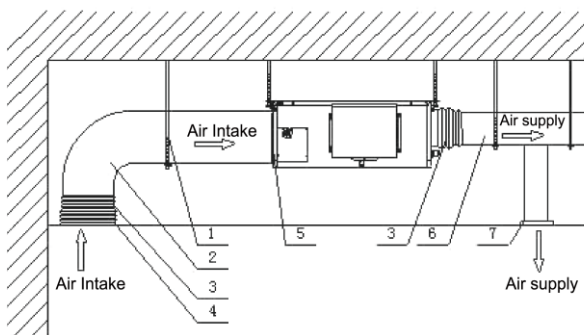



Figure 3-1-20

No.	Name	No.	Name
1	Hanger	5	Filter
2	Air Intake Pipe	6	Main Air Supply Pipe
3	Canvas Air Pipe	7	Air Supply Outlet
4	Air Intake		

 CAUTION!	
①.	The maximum length of the duct means the maximum length of the supply air duct plus the maximum length of the return air duct.
②.	The duct is rectangular and connected with the air inlet/outlet of the indoor unit. Among all supply air outlets, at least one should be kept open.

Bottom Return Air Installation only for Units 09/12/18k

(2) The default installation location of the rectangular flange is at the back and the return air cover plate is at the bottom, as shown in Figure 3-1-21.

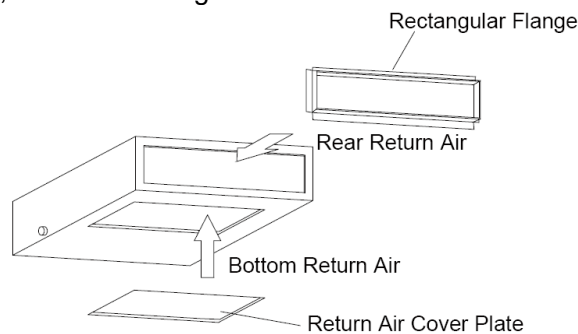

Figure 3-1-21

(3) If the bottom return air is desired, just change the place of the rectangular flange and the return air cover plate.

- (4) Connect one end of the return air duct to the return air outlet of the unit by rivets and the other to the return air louver. For the sake of the convenience to freely adjust the height, a cutting of canvas duct will be helpful, which can be reinforced and folded by 8# iron wire
- (5) More noise is likely to be produced in the bottom return air mode than the backward return air mode, so it is suggested to install a silencer and a static pressure box to minimize the noise.
- (6) The installation method can be chosen with considering the conditions of the building and maintenance etc., as shown in Figure 3-1-22.

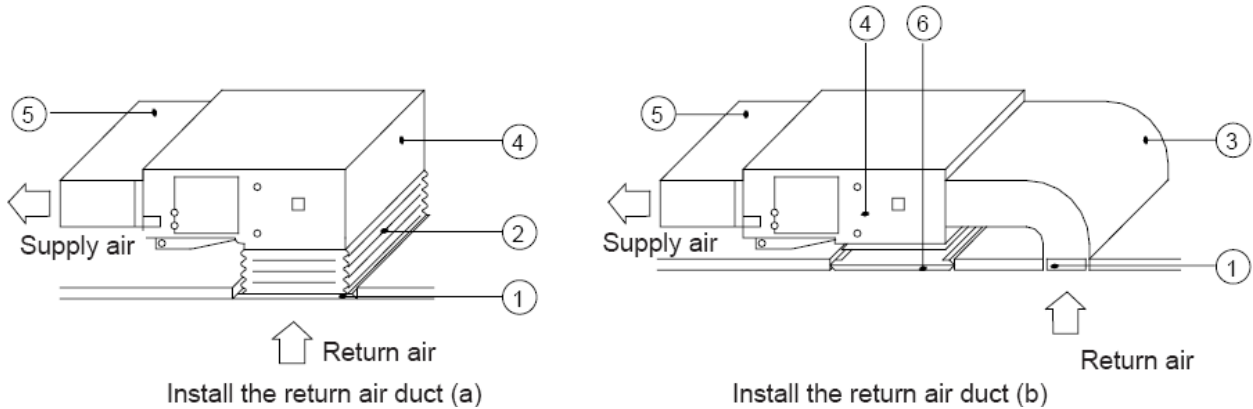

Figure 3-1-22

Table 3-1-4 Installation of the return air duct

No.	Name	No.	Name
1	Return Air Inlet (with filter)	4	Indoor unit
2	Canvas Duct	5	Supply Air Duct
3	Return Air Duct	6	Grille

1.2 Installation of Floor Ceiling Type

1.2.1 Before Installation

After receiving the machine, please check for any transport damage. If finding any surface or internal damage, please immediately report to the transport company or equipment company in writing.

After receiving the machine, please check the unit and accessories in reference to the packing list. Ensure that the model is correct and the machine is in good condition. Please also check if the specification and quantity of accessory parts are correct.

Determine the correct handling route and methods, thus to avoid damaging the unit or causing possible hazard. For the sake of protection and safety, it is suggested to move the unit with the packaging box. Even though it is not permitted to do like this under special occasions, do not remove the packaging box, thus to avoid loosening or falling during handling.

Confirm if the installing foundation is solid. When this unit is to be installed on the metal section of the building, make sure that the electrical insulation must comply with applicable standards.

Ensure that the place of installation is far from the area where the inflammable or explosive substances are stored, thus to avoid possible explosion or fire due to leakage.

1.2.2 Installation Site

- (1) Install the unit at a place where is strong enough to withstand the weight of the unit.
- (2) The air inlet and outlet of the unit should never be clogged so that the airflow can reach every

corner of the room.

(3) Leave service space around the unit as required in Figure 3-1-23.

◆ Floor type

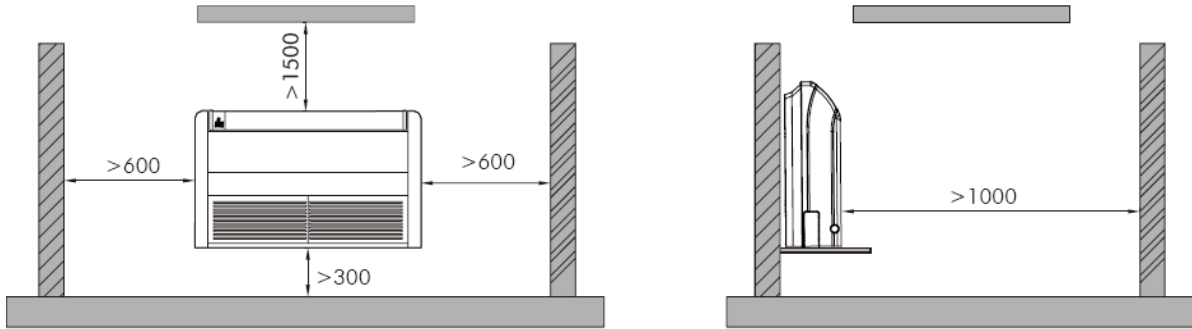

◆ Ceiling type

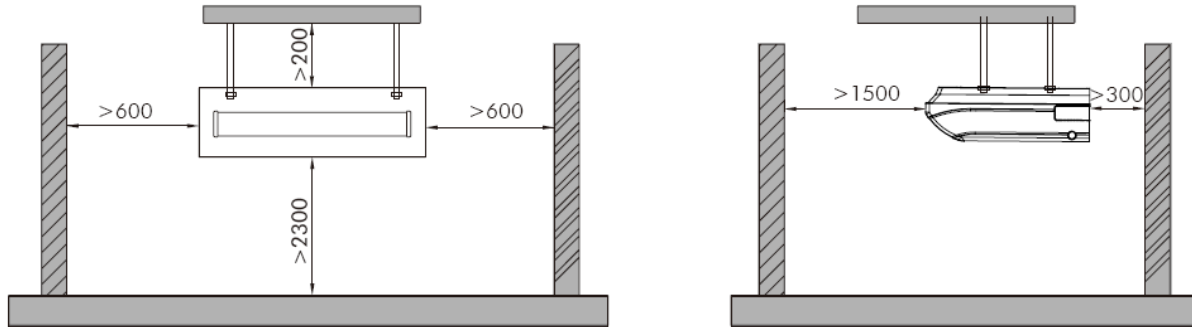

Figure 3-1-23

(4) Install the unit where the drain pipe can be easily installed.

(5) The space from the unit to the ceiling should be kept as much as possible so as for more convenient service.

1.2.3 Indoor Unit Installation

(1) Determine the location of the hanger through the paper template, and then remove the paper template.

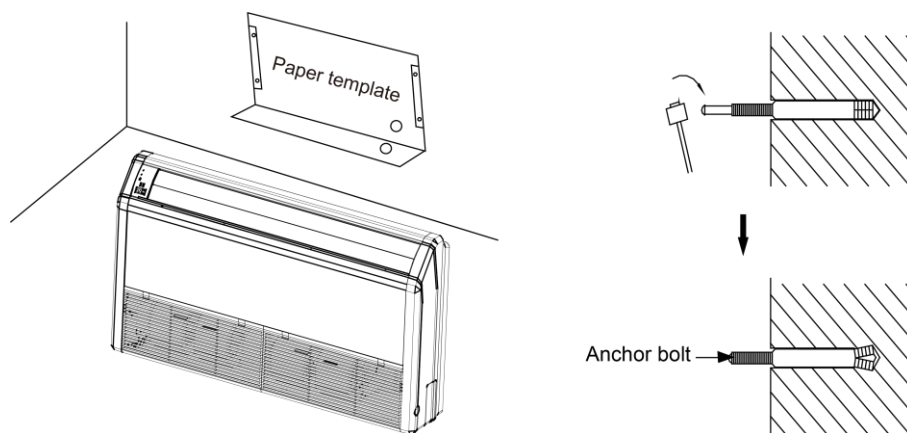

Figure 3-1-24

(2) Insert the anchor bolts into the drilled holes, and drive the pins completely into the anchor bolts with a hammer.

(3) Firstly unfix two buckles on the grille as shown on the picture. Remove the screws under the buckles by a screwdriver and then open the inlet grille.

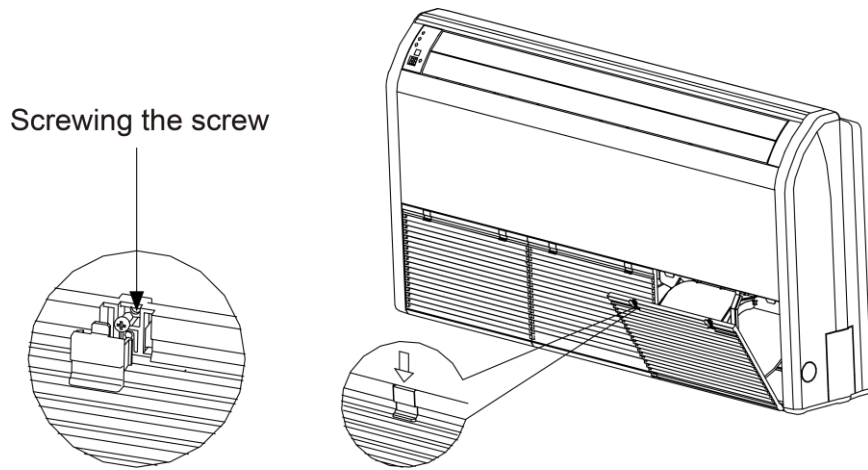

Figure 3-1-25

- (4) Remove the screws shown on the picture. Push the side plate as per the arrowed direction and take it down.

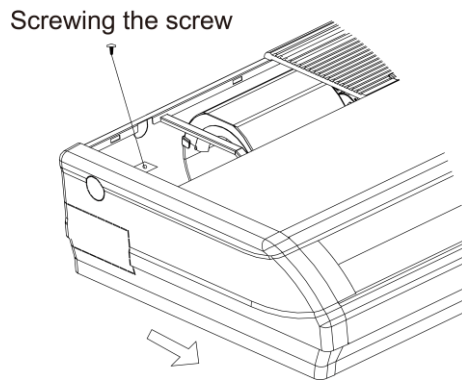

Figure 3-1-26

- (5) Put the hanger bolt into the clasp of the indoor unit and tighten screws on the hanger to prevent the indoor unit from moving.

- (6) Reinstall and tighten the right and left side panels.

◆ Floor type

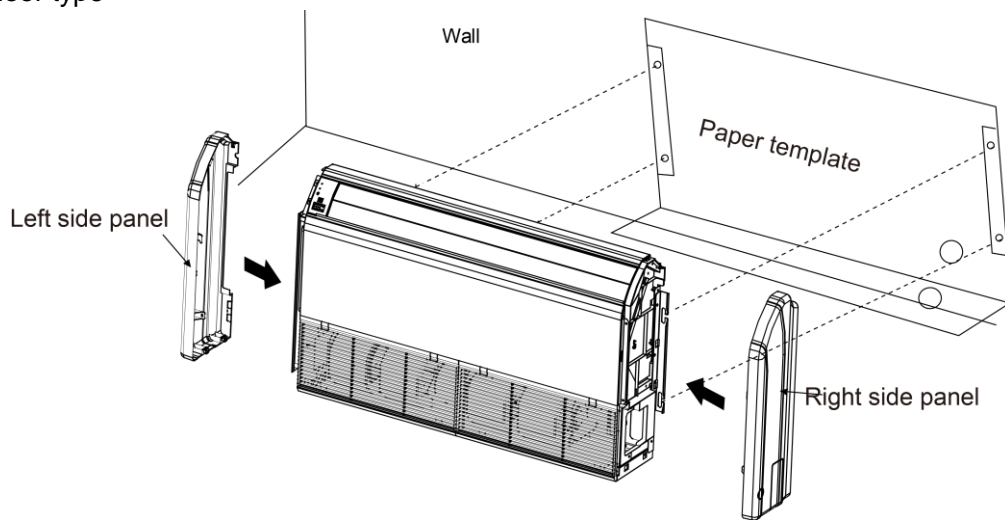

Figure 3-1-27

◆ Ceiling type

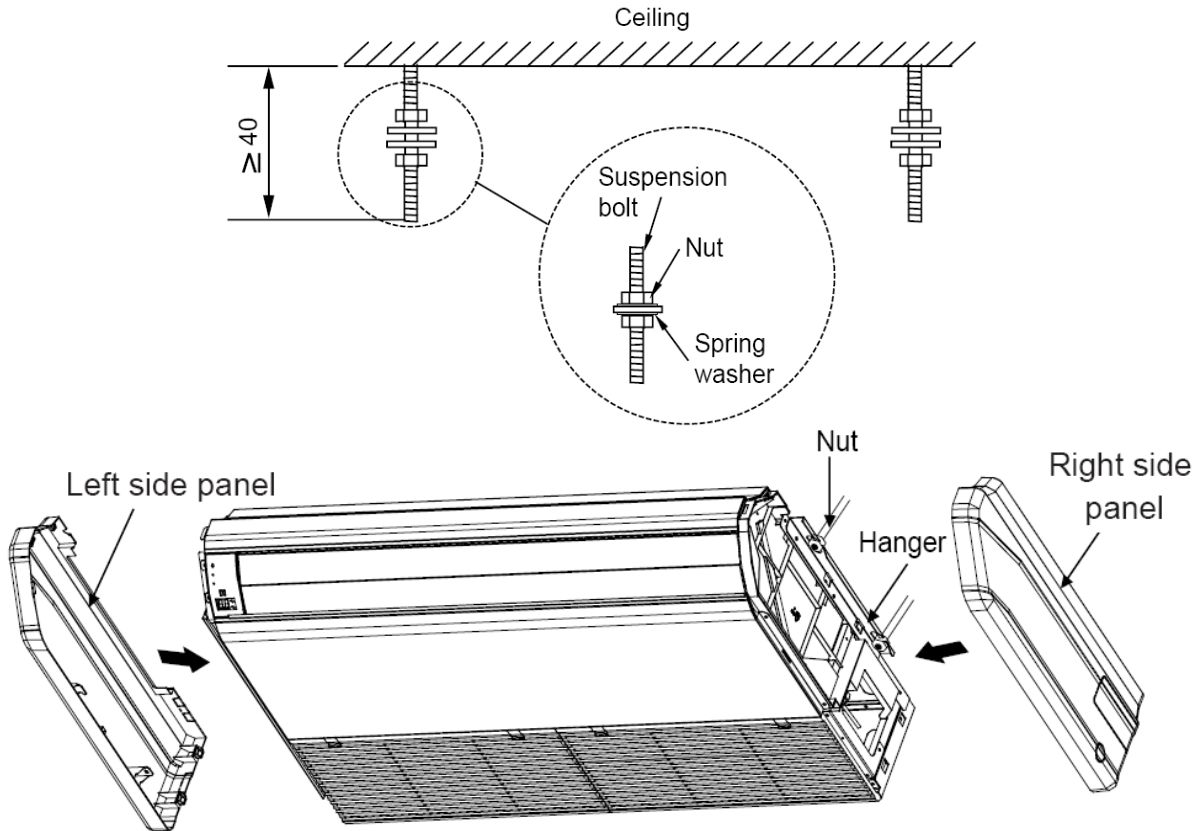

Figure 3-1-28

(7) Adjust the height of the unit to make the drain pipe slant slightly downward so that the drainage will become much smoother.

1.2.4 Leveling

The water level test must be done after installing the indoor unit to make the unit is horizontal, as shown below.

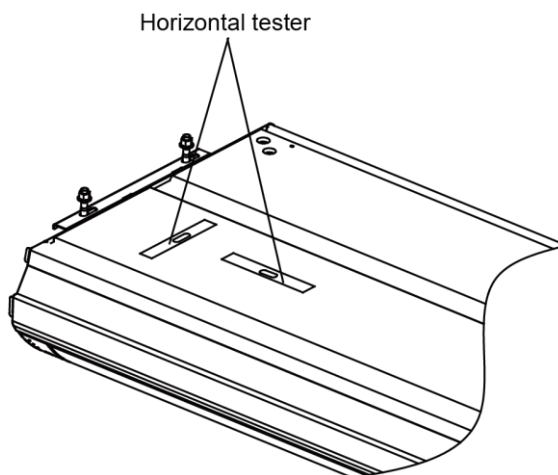

Figure 3-1-29

1.2.5 Dimension Data

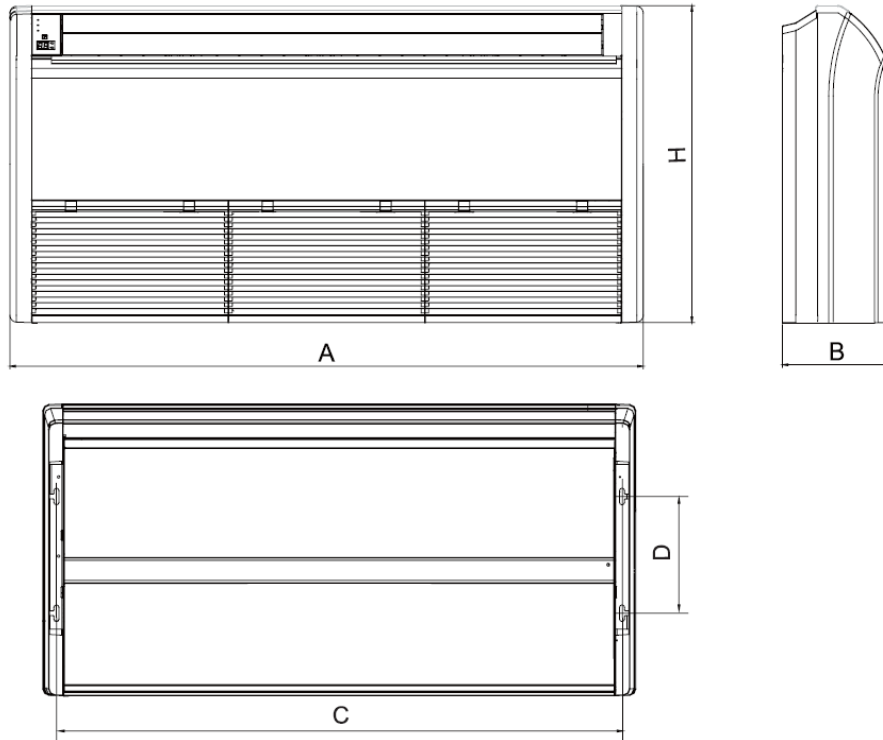

Figure 3-1-30
Table 3-1-5

Unit: mm

Model	A	B	C	D	H
GTH09K3FI	1220	225	1158	280	700
GTH12K3FI					
GTH18K3FI					
GTH24K3FI					
GTH30K3FI	1420	245	1354	280	700
GTH36K3FI					
GTH42K3FI					
GTH48K3FI	1700	245	1634	280	700
GTH60K3FI					

1.2.6 Drain Piping Work

1.2.6.1 Precautions When Doing the Piping Work

- (1) Keep piping as short as possible and slope it downwards at a gradient of at least 1/100 so that air may not remain trapped inside the pipe.
- (2) Keep pipe size equal to or greater than that of the connecting pipe.
- (3) Install the drain piping as shown and take measures against condensation. Improperly rigged piping could lead to leaks and eventually wet furniture and belongings.

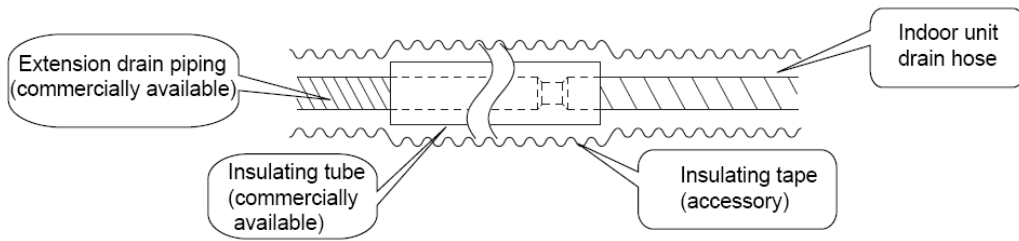

Figure 3-1-31

(4) Connect the drain hose. (Figure 3-1-32)

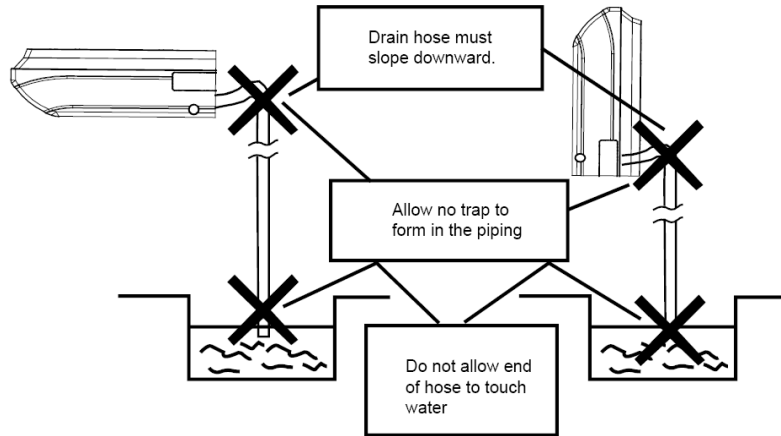

Figure 3-1-32

1.2.6.2 Installing the Drain Pipes

- (1) For determining the position of the drain hose, perform the following procedures.
- (2) Insert the drain pipe to the drain outlet of the unit and then tighten the clamp securely with tape. (Figure 3-1-33)
- (3) Connect the extension drain pipe to the drain pipe and then tighten the clamp with tape.

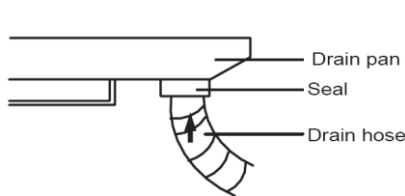

Figure 3-1-33

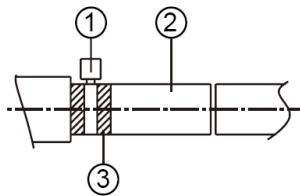

Figure 3-1-34

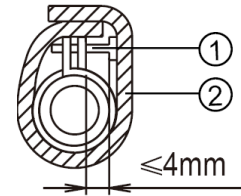

Figure 3-1-35

Tighten the clamp until the screw head is less than 4 mm from the hose. (Figure 3-1-34)

- ①- Metal clamp ②- Drain hose ③- Grey tape

Insulate the pipe clamp and the drain hose using heat insulation sponge. (Figure 3-1-35)

- ①- Metal clamp ②- Insulation sponge

- (4) When drain hose requires extension, obtain an extension hose commercially available.
- (5) After connecting the local drain hose, tape the slits of the heat insulation tube.
- (6) Connect the drain hose to the local drain pipe. Position the inter connecting wire in the same direction as the piping.

1.2.6.3 Connecting the Drain Hose

- (1) Connect the extension auxiliary pipe to the local piping.
- (2) Prepare the local piping at the connection point for the drain pipe, as shown in the installation drawings.

Note: Be sure to place the drain hose as shown in the diagram below, in a downward sloping direction.

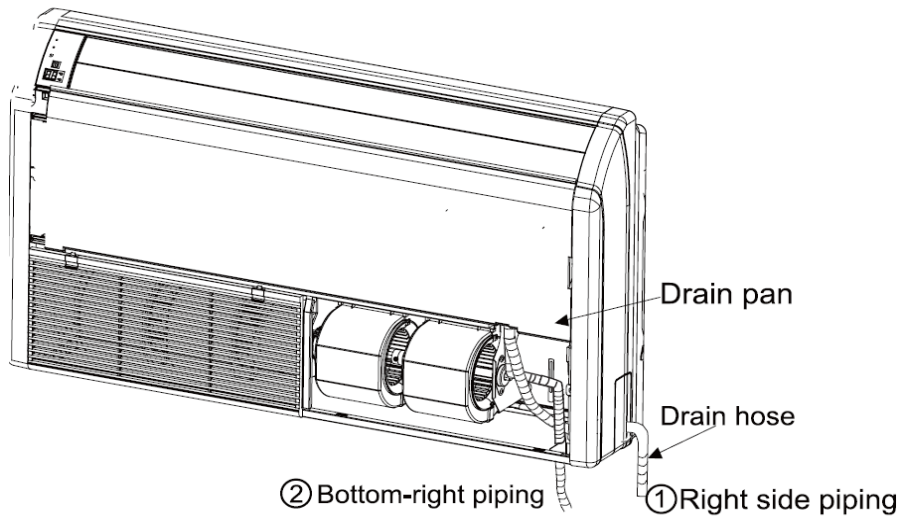

Figure 3-1-36

1.2.6.4 Testing of Drain Piping

- (1) After piping work is finished, check if drainage flows smoothly.
- (2) As shown in the figure, pour water into the drain pan from the right side to check that water flows smoothly from the drain hose.

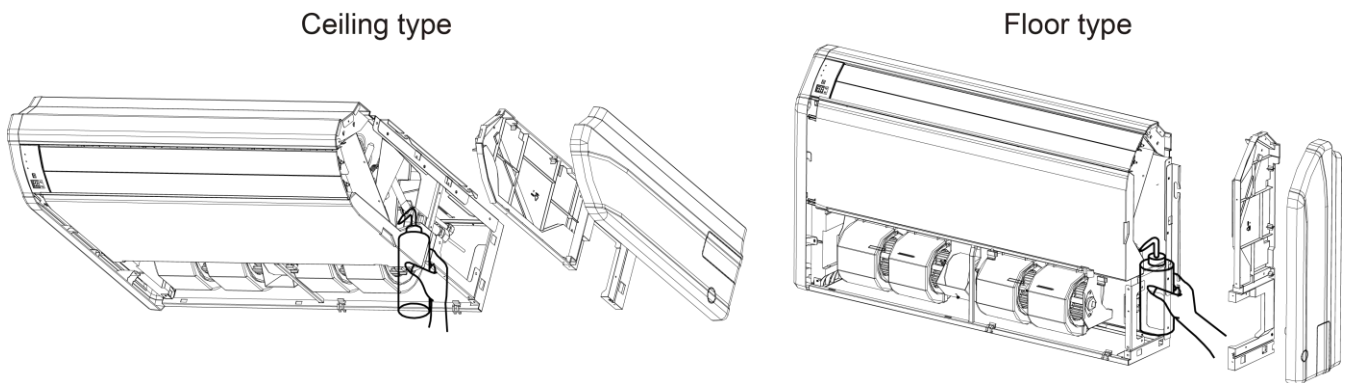

Figure 3-1-37

1.3 Installation of Cassette Type

1.3.1 Before Installation

After receiving the machine, please check for any transport damage. If finding any surface or internal damage, please immediately report to the transport company or equipment company in writing.

After receiving the machine, please check the unit and accessories in reference to the packing list. Ensure that the model is correct and the machine is in good condition. Please also check if the specification and quantity of accessory parts are correct.

Determine the correct handling route and methods, thus to avoid damaging the unit or causing possible hazard. For the sake of protection and safety, it is suggested to move the unit with the packaging box. Even though it is not permitted to do like this under special occasions, do not remove the packaging box, thus to avoid loosening or falling during handling.

Confirm if the installing foundation is solid. When this unit is to be installed on the metal section of the building, make sure that the electrical insulation must comply with applicable standards.

Ensure that the place of installation is far from the area where the inflammable or explosive substances are stored, thus to avoid possible explosion or fire due to leakage.

1.3.2 Installation Site

Select an installation site where the following conditions are fulfilled and that meets your customer's approval.

- (1) Obstruct should be put away from the intake or outlet vent of the indoor unit so that the airflow can be blown through all the room.
- (2) Make sure that the installation meets the requirement of the schematic diagram of installation spaces.
- (3) Select the place where can stand 4 times of the weight of the indoor unit and would not increase the operating noise and vibration.
- (4) The horizontality of the installation place should be guaranteed.
- (5) Select the place where is easy to drain out the condensate water, and connect with outdoor unit.
- (6) Make sure that there are enough space for care and maintenance, and the height fall between the indoor unit and ground is above 1800mm.
- (7) When installing the suspension bolt, check if the installation place can stand 4 times of the weight of the unit. If not, reinforce it before installation.

Note: There will be large amount of greasy dirt accumulated on the fan, heat exchanger and water pump located in the dining room and kitchen, which would reduce the capacity of the heater exchanger, lead to leakage and abnormal operation of the water pump.

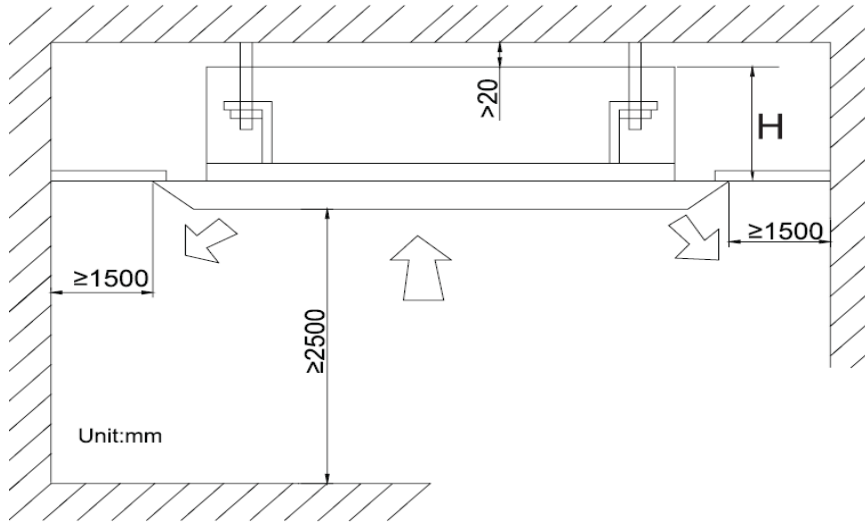
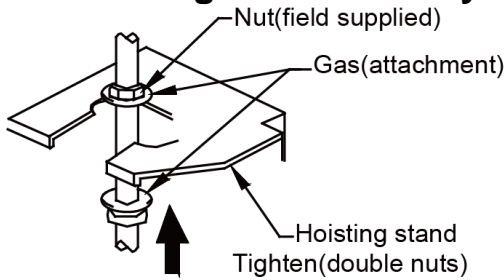

Figure 3-1-38

Table 3-1-6

Models	H(mm)
GKH12K3FI GKH18K3FI	255
GKH24K3FI	260
GKH30K3FI GKH36K3FI GKH42K3FI	340
GKH48K3FI GKH60K3FI	320

1.3.3 Installing the Main Body Unit



[Fix the hoisting stand firmly]

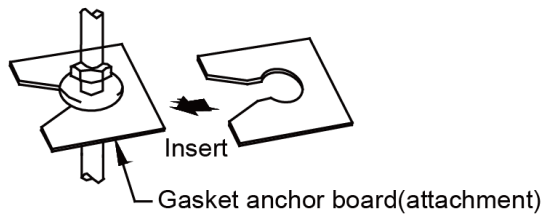

[Fix the gasket firmly]

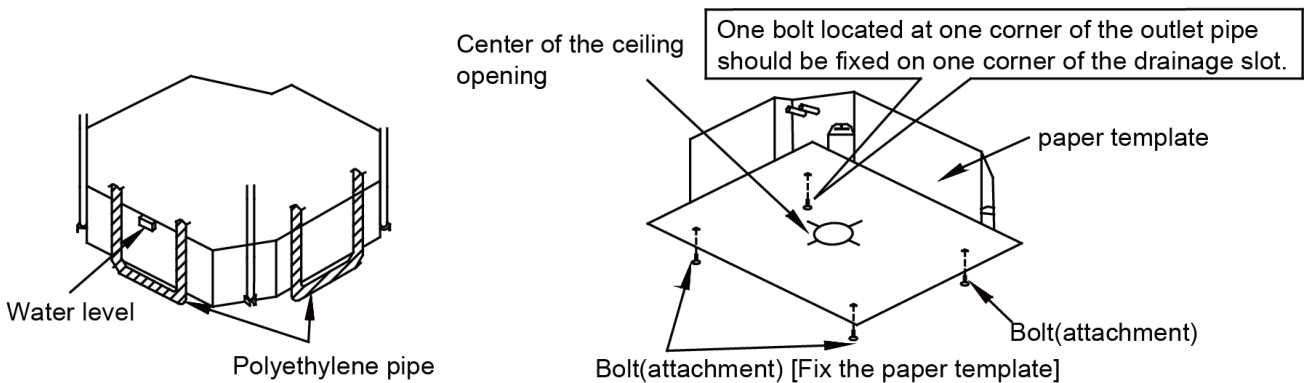

Figure 3-1-39

- (1) Install the hoisting stand on the hoisting screw by using nuts and gaskets at both the upper and lower sides of the hoisting stand. To prevent the gasket from breaking off, a gasket anchor board can be helpful.

- (2) Install the paper template on the unit, and fix the drain pipe at the outlet vent.
- (3) Adjust the unit to the best position.
- (4) Check if the unit is installed horizontally at four directions. If not, the water pump and the float switch would function improperly and even lead to water leakage.
- (5) Remove the gasket anchor board and tighten the nut remained.
- (6) Remove the paper template.

1.3.4 Installing the Suspension Bolts

- (1) Using the installation template, drill holes for bolts (four holes). (Figure 3-1-40)
- (2) Install the bolts to the ceiling at a place strong enough to hang the unit. Mark the bolt positions from the installation template. With a concrete drill, drill for 12.7 mm (1/2") diameter holes. (Figure 3-1-41)
- (3) Insert the anchor bolts into the drilled holes, and drive the pins completely into the anchor bolts with a hammer. (Figure 3-1-42)

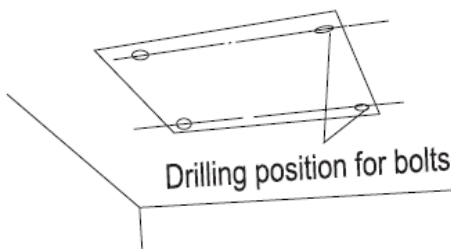

Figure 3-1-40

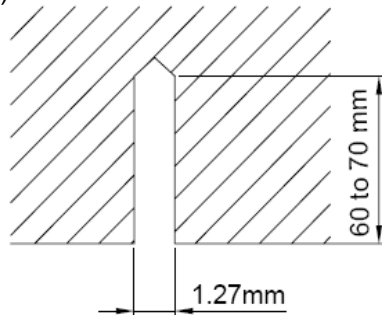

Figure 3-1-41

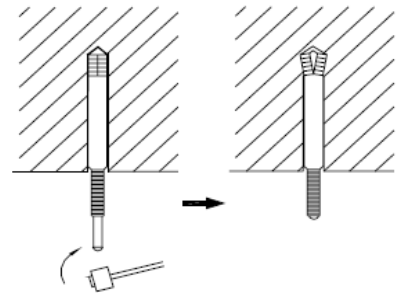

Figure 3-1-42

1.3.5 Leveling

The water level test must be done after installing the indoor unit to make the unit is horizontal, as shown below.

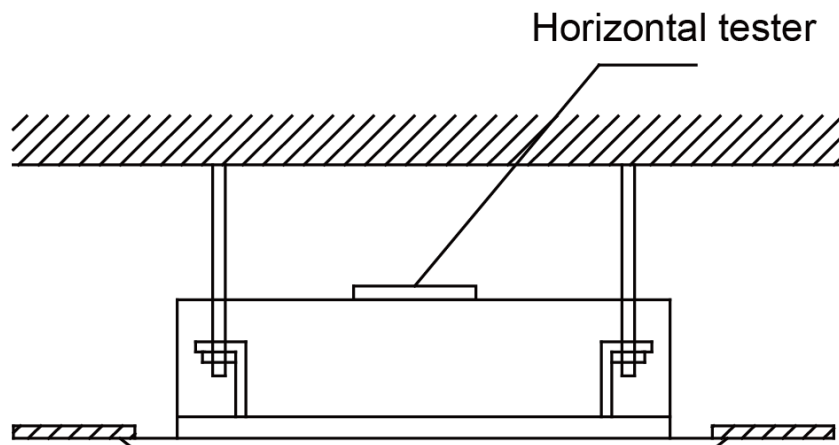

Figure 3-1-43

1.3.6 The Panel Installation

(1) See the figure below for the relationship of the front panel and the connecting pipe.

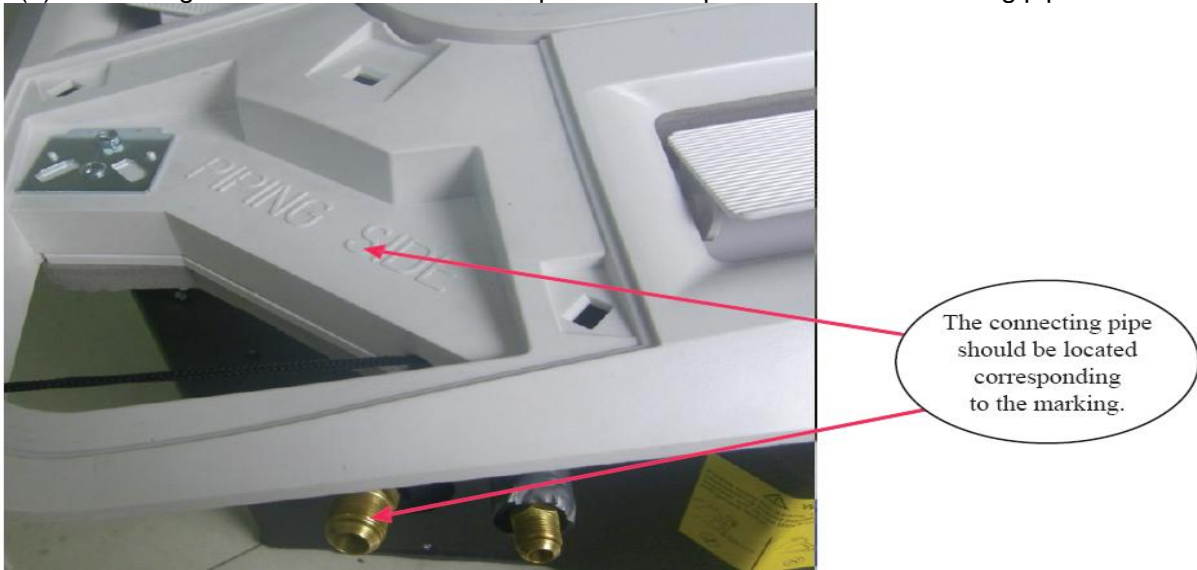

Figure 3-1-44

(2) Place the panel at the unit, and latch the hooks beside and opposite the swing flap motor.

(3) Latch other two hooks.

(4) Tighten four hexagonal screws under the latches about 15mm.

(5) Adjust the panel along the direction indicated by the arrow as shown in Figure 3-1-45.

(6) Tighten the screws until the thickness of the sealing material between the panel and the indoor unit reduces to 5-8mm.

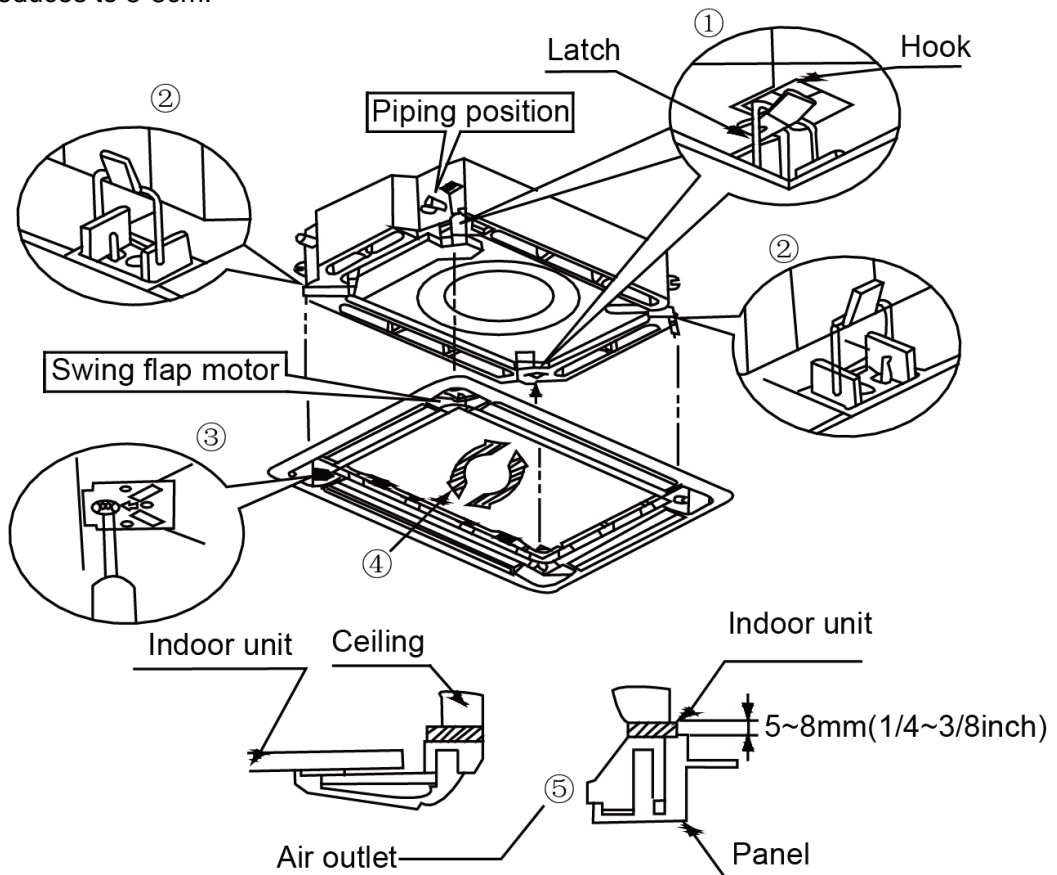

Figure 3-1-45

(7) Improper screwing of the screws may cause the troubles shown in Figure 3-1-46.

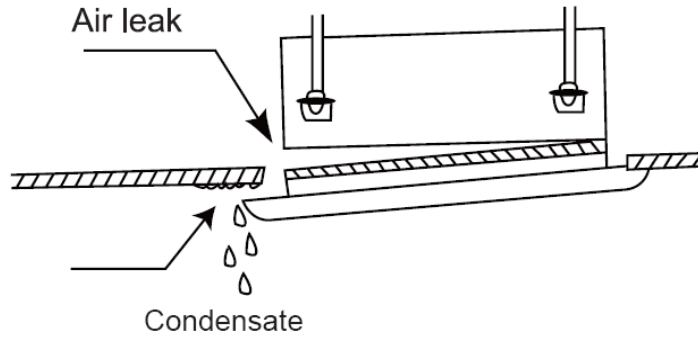

Figure 3-1-46

(8) If gap still exists between ceiling and decoration panel after tightening the screws, readjust the height of the indoor unit. (Figure 3-1-47)

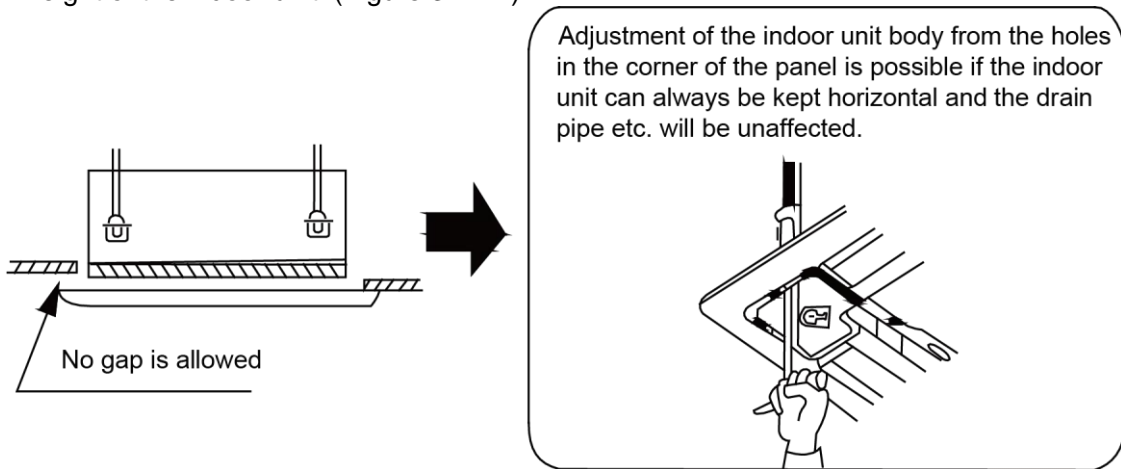

Figure 3-1-47

(9) Wire the swing flap motor as shown in Figure 3-1-48.

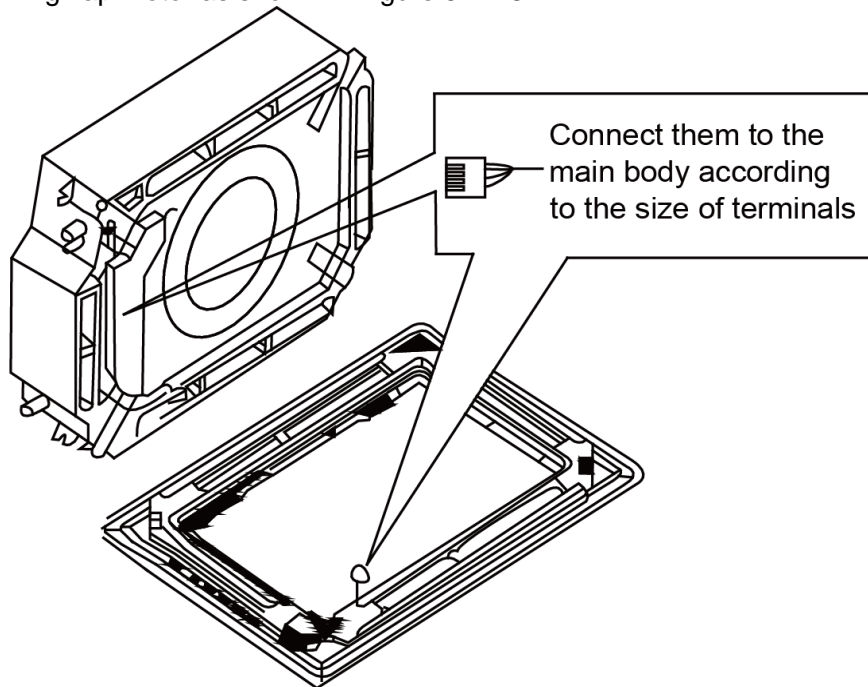

Figure 3-1-48

1.3.7 Dimension Data

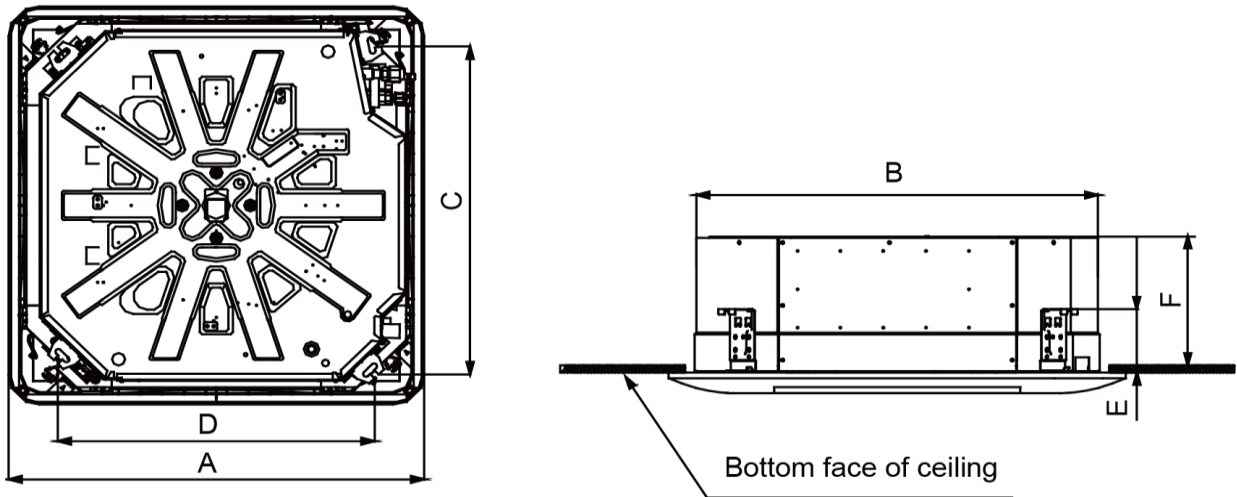

Figure 3-1-49
Table 3-1-7

Model \ Item	A	B	C	D	E	F
GKH12K3FI	670	595	592	571	145	240
GKH18K3FI						
GKH24K3FI	950	840	780	680	160	240
GKH30K3FI	950	840	892	980	160	320
GKH36K3FI						
GKH42K3FI						
GKH48K3FI	1040	910	842	788	170	290
GKH60K3FI						

1.3.8 Installation of Drain Piping

- (1) Keep piping as short as possible and slope it downwards at a gradient of at least 1/100 so that air may not remain trapped inside the pipe.
- (2) Keep pipe size equal to or greater than that of the connecting pipe.
- (3) Install the drain piping as shown and take measures against condensation. Improperly rigged piping could lead to leaks and eventually wet furniture and belongings.

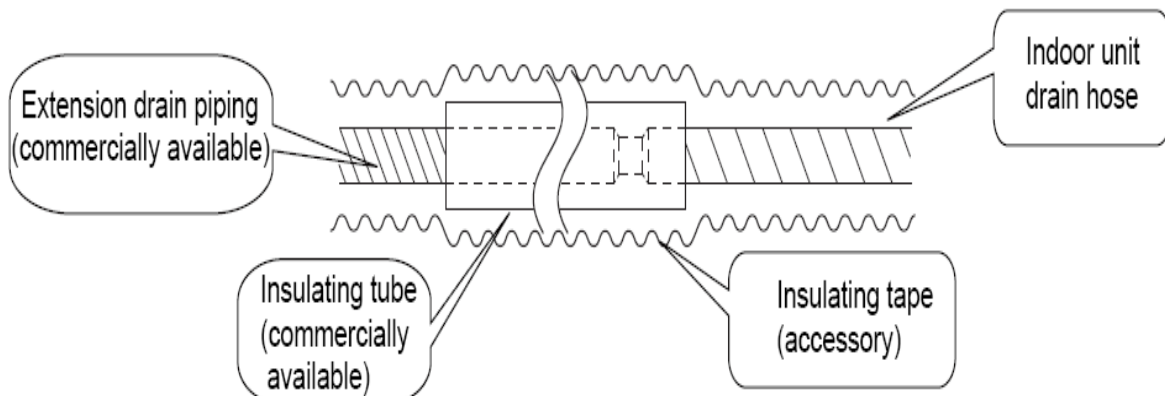
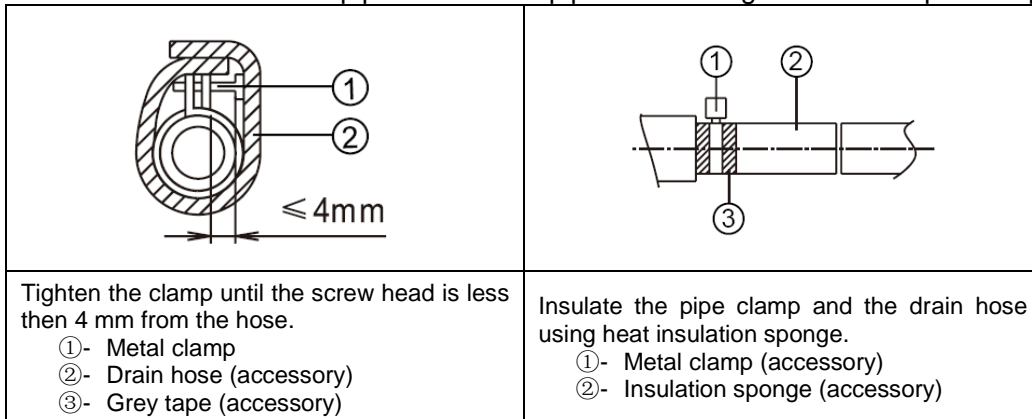

Figure 3-1-50

1.3.9 Installing the Drain Pipes

- (1) Insert the drain pipe to the drain outlet of the unit and then tighten the clamp securely with tape.
- (2) Connect the extension drain pipe to the drain pipe and then tighten the clamp with tape.



- (3) When unifying multiple drain pipes, install the pipes as Figure 3-1-51. Select converging drain pipes whose gauge is suitable for the operating capacity of the unit. (take the cassette type unit for example)

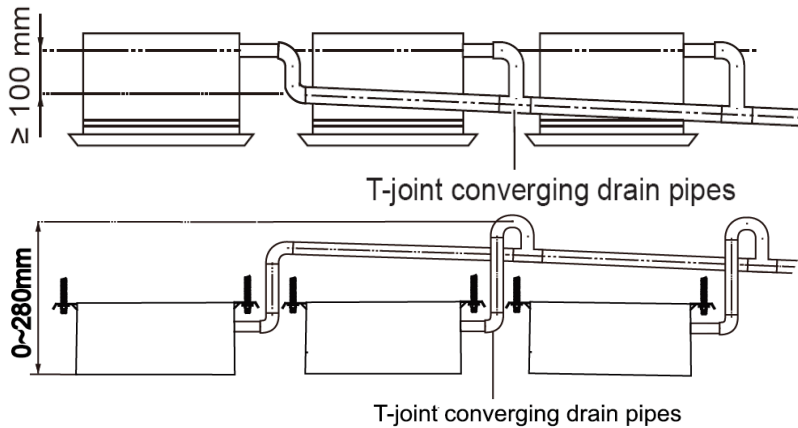

Figure 3-1-51

- (4) When the drain hose cannot keep a sufficient gradient, it is necessary to fit a riser pipe (field supplied) to it.
- (5) If the air flow of indoor unit is high, this might cause negative pressure and result in return suction of outdoor air. Therefore, U-type water trap shall be designed on the drainage side of each indoor unit. (Figure 3-1-52)
- (6) Install one water trap for each unit.
- (7) Installation of water trap shall consider easy cleaning in the future.

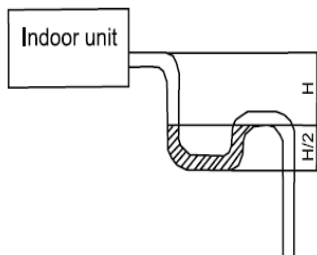

Figure 3-1-52

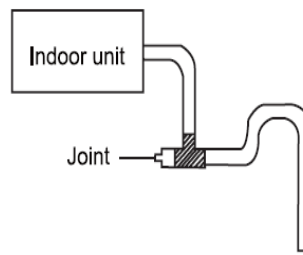

Figure 3-1-53

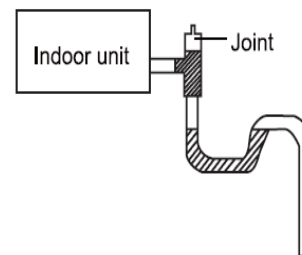

Figure 3-1-54

- (8) Connection of drainage branch pipe to the standpipe or horizontal pipe of drainage main pipe

The horizontal pipe cannot be connected to the vertical pipe at a same height. It can be connected in a manner as shown below:

NO.1: Attach the 3-way connection of the drainage pipe joint as shown in Figure 3-1-55.

NO.2: Attach the drain elbow as shown in Figure 3-1-56.

NO.3: Attach the horizontal pipe as shown in Figure 3-1-57.

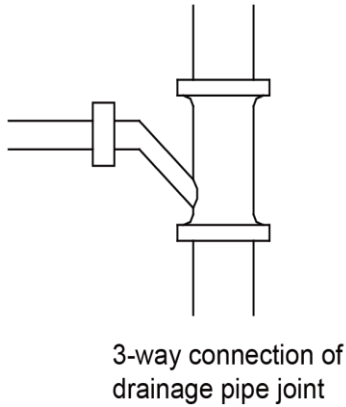

Figure 3-1-55

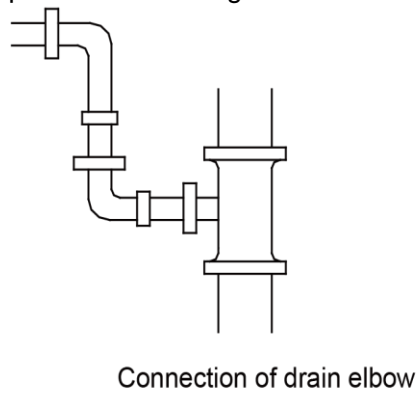

Figure 3-1-56

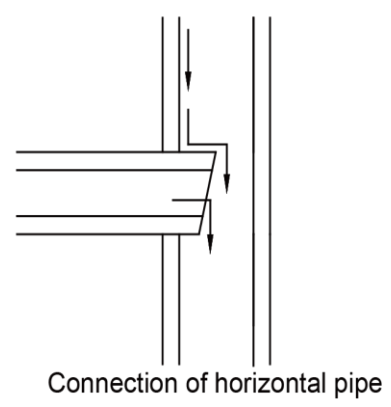

Figure 3-1-57

1.3.10 Precautions When Doing Riser Piping Work

(1) Make sure that heat insulation work is executed on the following 2 spots to prevent any possible water leakage due to dew condensation.

- 1) Connect the drain hose to the drain lift pipe, and insulate them.
- 2) Connect the drain hose to the drain outlet on the indoor unit, and tighten it with the clamp.

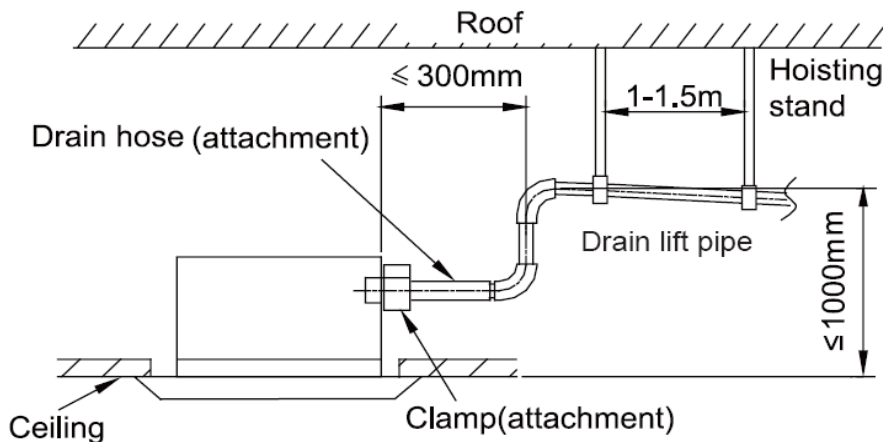

Figure 3-1-58

(2) Make sure the lift pipe is at most 280 mm.

(3) Stand the lift pipe vertically, and make sure it is not further than 300 mm from the base of the drain outlet.

(4) Secure a downward gradient of 1/100 or more for the drain pipe. To accomplish this, mount supporting brackets at an interval of 1 - 1.5 m.

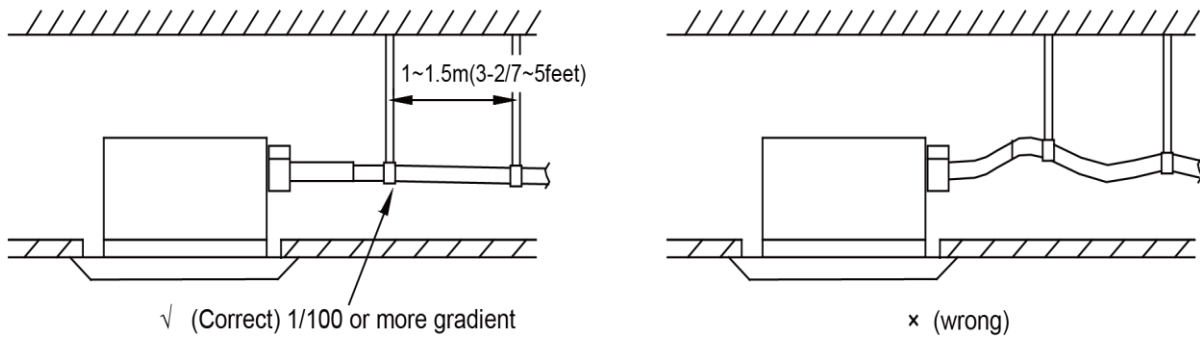

Figure 3-1-59

(5) The incline of attached drain hose should be 75 mm or less so that the drain outlet does not have to withstand additional force.

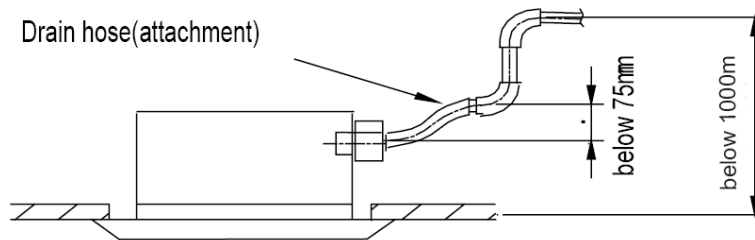

Figure 3-1-60

1.3.11 Testing of Drain Piping

After piping work is finished, check if drainage flows smoothly. Shown in the Figure 3-1-61, Add approximately 1liter of water slowly into the drain pan and check drainage flow during COOL running.

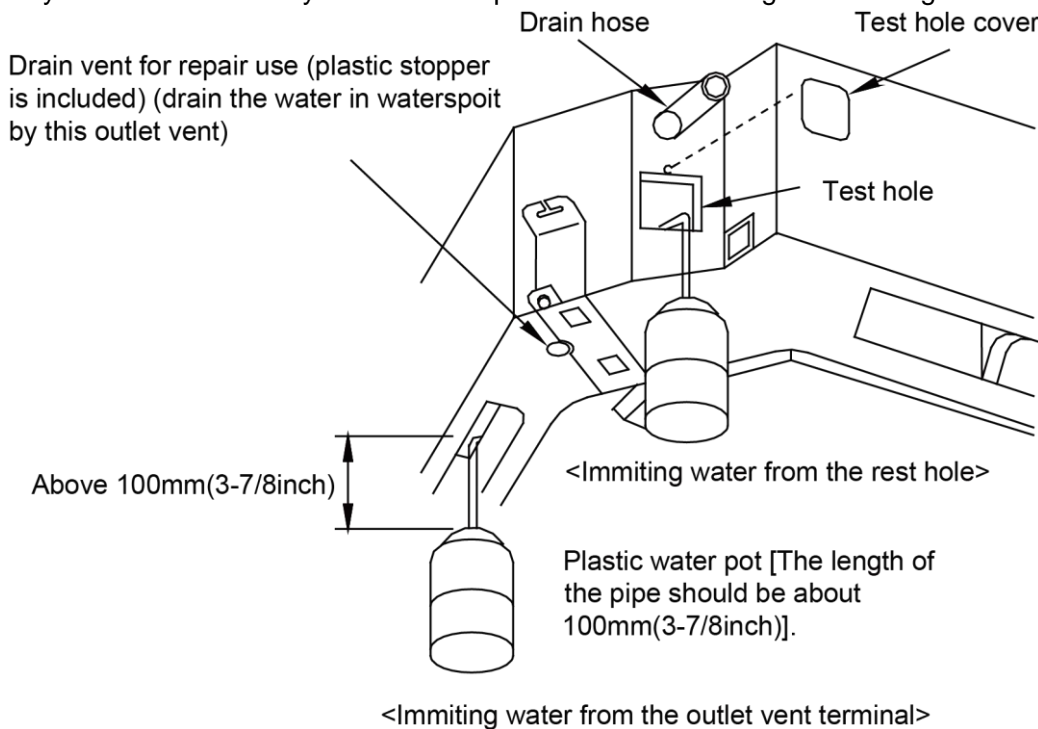

Figure 3-1-61

2 OUTDOOR UNIT INSTALLATION

2.1 Before Installation

After receiving the machine, please check for any transport damage. If finding any surface or internal damage, please immediately report to the transport company or equipment company in writing.

After receiving the machine, please check the unit and accessories in reference to the packing list. Ensure that the model is correct and the machine is in good condition. Please also check if the specification and quantity of accessory parts are correct.

Determine the correct handling route and methods, thus to avoid damaging the unit or causing possible hazard. For the sake of protection and safety, it is suggested to move the unit with the packaging box. Even though it is not permitted to do like this under special occasions, do not remove the packaging box, thus to avoid loosening or falling during handling.

Confirm if the installing foundation is solid. When this unit is to be installed on the metal section of the building, make sure that the electrical insulation must comply with applicable standards.

Ensure that the place of installation is far from the area where the inflammable or explosive substances are stored, thus to avoid possible explosion or fire due to leakage.

2.2 Installation Site

 WARNING
①. Install the unit where it will not be tilted by more than 5°.
②. During installation, if the outdoor unit has to be exposed to strong wind, it must be fixed securely.

If possible, do not install the unit where it will be exposed to direct sunlight. (If necessary, install a blind that does not interfere with the air flow.)

- (1) Install the outdoor unit in a place where it will be free from being dirty or getting wet by rain as much as possible.
- (2) Install the outdoor unit where it is convenient to connect with the indoor unit.
- (3) Install the outdoor unit where the condensate water can be drained out freely during heating operation.
- (4) Do not place animals and plants in the path of the warm air.
- (5) Take the air conditioner weight into account and select a place where noise and vibration are small.
- (6) Install the outdoor unit where is capable of withstanding the weight of the unit and generates as less noise and vibration as possible.
- (7) Provide the space shown in Figure 3-2-1, so that the air flow is not blocked. Also for efficient operation, leave three of four directions of peripheral constructions open.

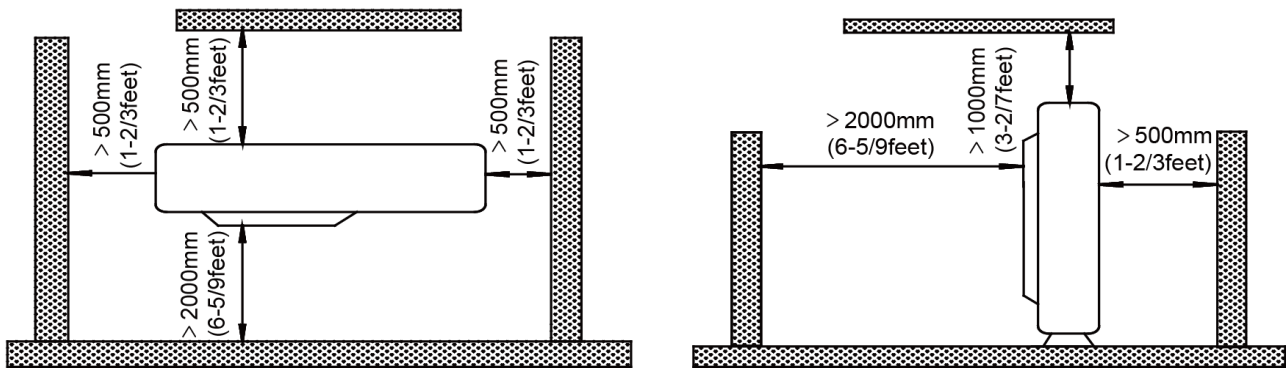

Figure 3-2-1

2.3 Caution for Installation

The outdoor unit shall be so installed that the air discharged out of the outdoor unit will not flow back and that enough space shall be maintained around the machine for repair;

The installing position shall be in good ventilation, so that the machine can breathe and exhaust enough air. Ensure that there is no obstruction at the inlet and outlet of the machine. If any, please remove the obstructions blocking the air inlet and outlet.

If the outdoor unit is installed on concrete or solid ground, it shall be fixed by using M10 bolts and nuts. And ensure that the machine is kept vertical and horizontal.

The outdoor unit must be lifted by using the designated lift hole. During lifting, take care to protect the air conditioner and avoid knocking the metal parts, thus to prevent rusting in the future.

To meet the noise and vibration requirements, the outdoor unit shall be installed by using rubber damping pad or spring damper.

To install the drainage pipe, please insert the drainage joint to the drainage hole on the outdoor chassis and connect a drainage pipe on the drainage joint. (The installing height of outdoor unit shall be at least 5cm if drainage joint is to be used).

To insert the pipe through the wall, the wall-cross tube must be installed.

The installing dimension shall comply with the installation requirements in these instructions. The outdoor unit must be fixed at the installing position.

The installation shall be done by specialist technicians.

2.4 Dimension Data

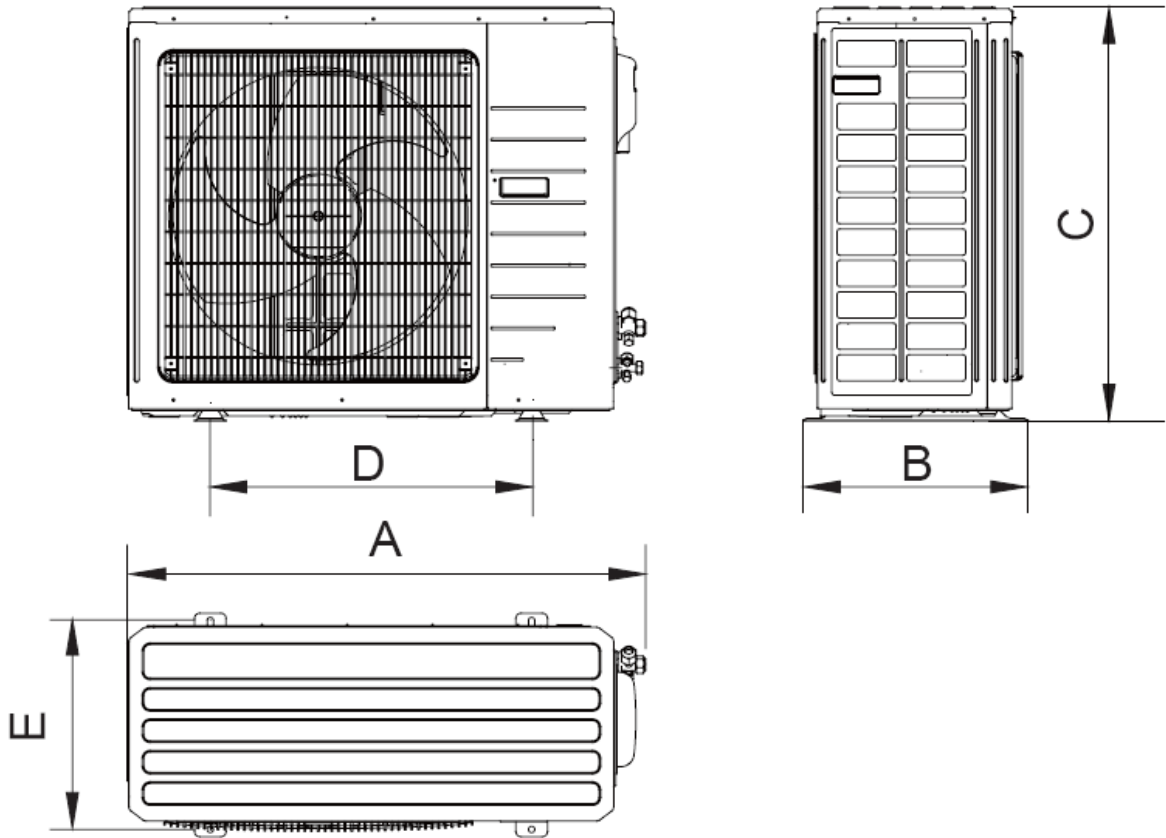

Figure 3-2-2
Table 3-2-1

Unit: mm

Model \ Item	A	B	C	D	E
GUHD09NK3FO	850	320	540	540	286
GUHD12NK3FO					
GUHD18NK3FO	955	395	700	560	360
GUHD24NK3FO	980	425	790	610	395
GUHD30NK3FO					
GUHD36NK3FO	1105	440	1100	631	400
GUHD36NM3FO					
GUHD42NM3FO	960	410	1350	572	376
GUHD42NK3FO					
GUHD48NK3FO					
GUHD48NM3FO					
GUHD60NM3FO	1085	425	1365	620	395

3 REFRIGERATION PIPING WORK

3.1 Refrigeration Piping Work Procedures and Caution in Connecting

3.1.1 Flare Processing

- (1) Cut the connection pipe with the pipe cutter and remove the burrs.
- (2) Hold the pipe downward to prevent cuttings from entering the pipe.
- (3) Remove the flare nuts at the stop valve of the outdoor unit and inside the accessory bag of the indoor unit, then insert them to the connection pipe, after that, flare the connection pipe with a flaring tool.
- (4) Check if the flare part is spread evenly and there are no cracks (see Figure 3-2-3).

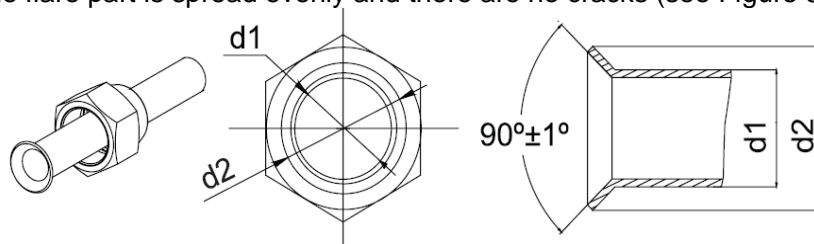

Figure 3-2-3

3.1.2 Bending Pipes

- (1) The pipes are shaped by your hands. Be careful not to collapse them.

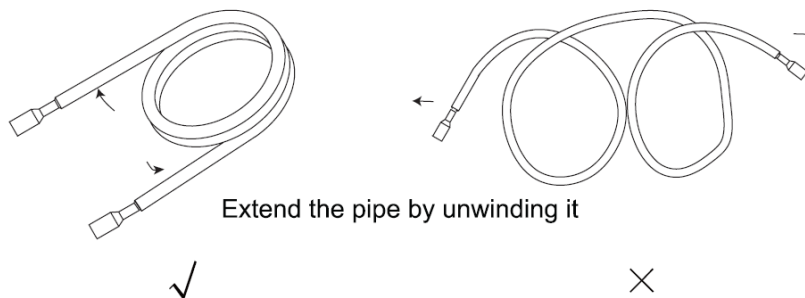

Figure 3-2-4

- (1) Do not bend the pipes in an angle more than 90°.
- (2) When pipes are repeatedly bent or stretched, the material will harden, making it difficult to bend or stretch them any more. Do not bend or stretch the pipes more than three times.
- (3) When bending the pipe, do not bend it as is. The pipe will be collapsed. In this case, cut the heat insulating pipe with a sharp.

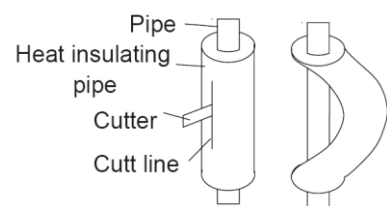



Figure 3-2-5

- (4) Cutter as shown in Figure 3-2-5, and bend it after exposing the pipe. After bending the pipe as you want, be sure to put the heat insulating pipe back on the pipe, and secure it with tape.

 CAUTION!
①. To prevent breaking of the pipe, avoid sharp bends. Bend the pipe with a radius of curvature of 150 mm or over.
②. If the pipe is bent repeatedly at the same place, it will break.

3.1.3 Connecting the Pipe at the Indoor Unit Side

Detach the caps and plugs from the pipes.

 CAUTION!
①. Be sure to apply the pipe against the port on the indoor unit correctly. If the centering is improper, the flare nut cannot be tightened smoothly. If the flare nut is forced to turn, the threads will be damaged.
②. Do not remove the flare nut until the connection pipe is to be connected so as to prevent dust and impurities from coming into the pipe system.

When connecting the pipe to the unit or removing it from the unit, please do use both the spanner and the torque wrench. (Figure 3-2-6)

When connecting, smear both inside and outside of the flare nut with refrigeration oil, screw it hand tight and then tighten it with the spanner.

Refer to Table 10 to check if the wrench has been tightened properly (too tight would mangle the nut and lead to leakage).

Examine the connection pipe to see if it leaks, then take the treatment of heat insulation, as shown in the Figure 3-2-6.

Use the medium-sized sponge to insulate the coupler of the gas pipe.

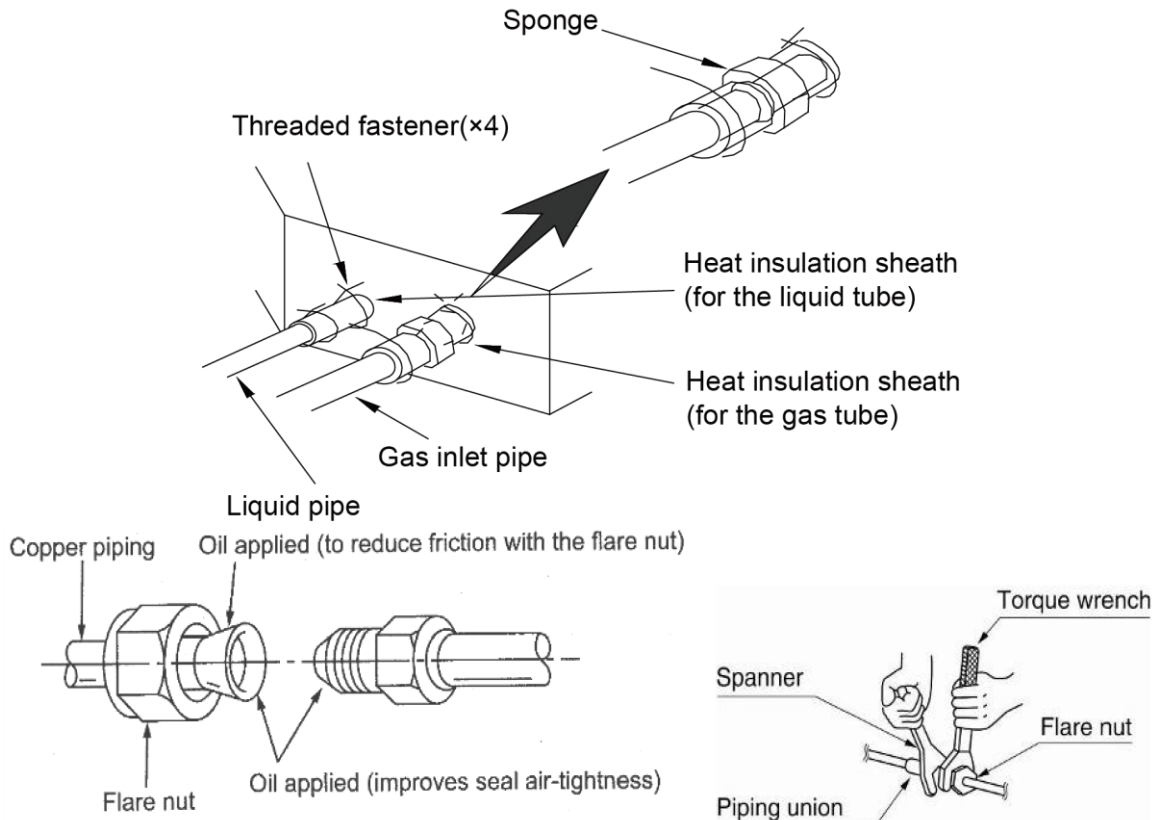



Figure 3-2-6

Table 3-2-2 Flare nut tightening torque

Pipe Diameter	Tightening Torque
1/4" (Inch)	15-30 (N·m)
3/8" (Inch)	35-40 (N·m)
1/2" (Inch)	45-50 (N·m)
5/8" (Inch)	60-65 (N·m)
3/4" (Inch)	70-75 (N·m)
7/8" (Inch)	80-85 (N·m)



CAUTION!

Be sure to connect the gas pipe after connecting the liquid pipe completely.

3.1.4 Connecting the Pipe at the Outdoor Side Unit

Tighten the flare nut of the connection pipe at the outdoor unit valve connector. The tightening method is the same as that as at the indoor side.

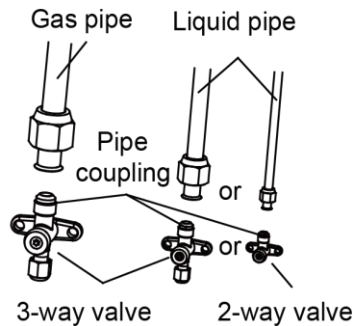

Figure 3-2-2

3.1.5 Checking the Pipe Connections for Gas Leaking

For both indoor and outdoor unit side, check the joints for gas leaking by the use of a gas leakage detector without fail when the pipes are connected.

3.1.6 Heat Insulation on the Pipe Joints (Indoor Side Only)

Stick coupler heat insulation (large and small) to the place where connecting pipes.

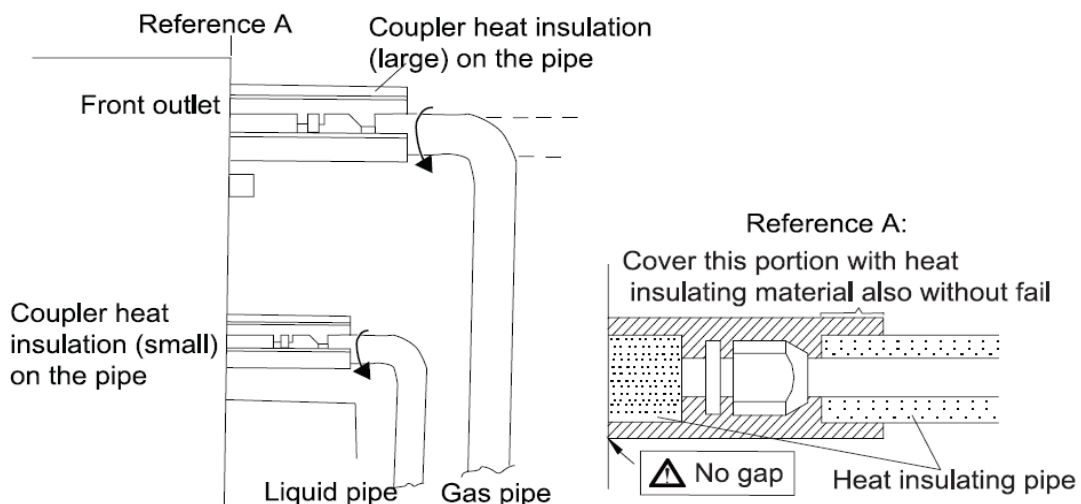

Figure 3-2-3

3.1.7 Vacuum and Gas Leakage Inspection



Do not purge the air with refrigerants but use a vacuum pump to vacuum the installation! There is no extra refrigerant in the outdoor unit for air purging!

3.1.7.1 Vacuum

- (1) Remove the caps of the liquid valve, gas valve and also the service port.
- (2) Connect the hose at the low pressure side of the manifold valve assembly to the service port of the unit's gas valve, and meanwhile the gas and liquid valves should be kept closed in case of refrigerant leak.
- (3) Connect the hose used for evacuation to the vacuum pump.
- (4) Open the switch at the lower pressure side of the manifold valve assembly and start the vacuum pump. Meanwhile, the switch at the high pressure side of the manifold valve assembly should be kept closed, otherwise evacuation would fail.
- (5) The evacuation duration depends on the unit's capacity, generally, 15 minutes for the 09k/12k units, 20 minutes for the 18k units, 30 minutes for the 24/30/36k units, 45 minutes for the 42/48/60k units. And verify if the pressure gauge at the low pressure side of the manifold valve assembly reads -1.0Mp (-75cmHg), if not, it indicates there is leak somewhere. Then, close the switch fully and then stop the vacuum pump.
- (6) Wait for some time to see if the system pressure can remain unchanged, 3 minutes for the units less than 18k, 5 minutes for the 18k~24k units, 10 minutes for the units more than 42k. During this time, the reading of the pressure gauge at the low pressure side can not be larger than 0.005Mp (0.38cmHg).
- (7) Slightly open the liquid valve and let some refrigerant go to the connection pipe to balance the pressure inside and outside of the connection pipe, so that air will not come into the connection pipe when removing the hose. Note that the gas and liquid valve can be opened fully only after the manifold valve assembly is removed.
- (8) Place back the caps of the liquid valve, gas valve and also the service port.

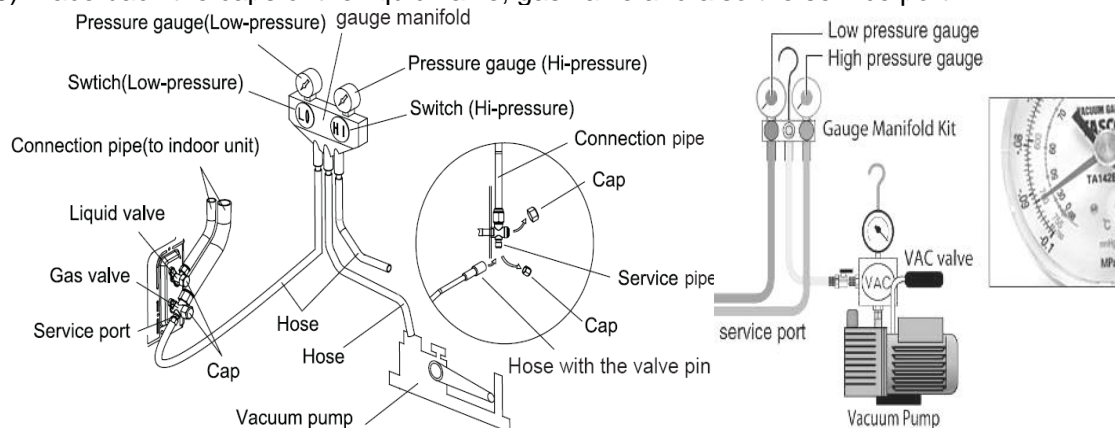

Figure 3-2-4

Note: For the large-sized unit, it has the service port for both the gas valve and the liquid valve. During evacuation, it is available to connect two hoses of the manifold valve assembly to two service ports to quicken the evacuating speed.

3.1.7.2 Additional Charge

Refrigerant suitable for a piping length of 5m is charged in the outdoor unit at the factory.

When the piping is longer than 7 m, additional charging is necessary.

For the additional amount, see Table 3-2-3.

Table 3-2-3

Model \ Item	Standard Pipe Length	Unnecessary Charge Pipe Length	Additional Refrigerant Amount for Extra Pipe
09~18k	5.0m	≤7.0m	30 g/m
24~42k	5.0m	≤7.0m	60 g/m
48~60k	7.5m	≤ 9.5m	60 g/m

When the height difference between the indoor unit and outdoor unit is larger than 10 meters, an oil bend should be employed for every 6 meters.

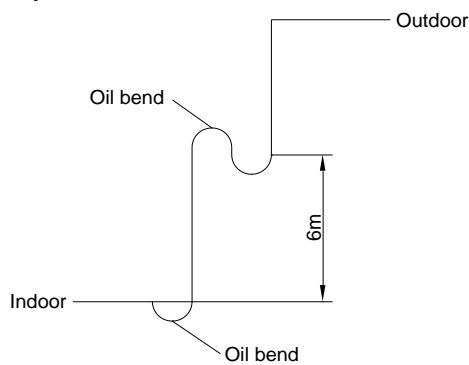

Figure 3-2-5

3.2 Specification of Connection Pipe

Table 3-2-4

Model \ Item	Size of Fitting Pipe(Inch)		Max. Pipe Length (m)	Max. Height Difference between Indoor Unit and Outdoor Unit (m)	Drainage pipe(Outer Diameter x wall thickness) (mm)
	Liquid	Gas			
GUHD09NK3FO	1/4	3/8	20	15	Φ17×1.75
GUHD12NK3FO	1/4	3/8	20	15	Φ17×1.75
GUHD18NK3FO	1/4	1/2	20	15	Φ17×1.75
GUHD24NK3FO	3/8	5/8	30	15	Φ17×1.75
GUHD30NK3FO	3/8	5/8	30	15	Φ17×1.75
GUHD36NK3FO	3/8	5/8	30	15	Φ17×1.75
GUHD42NK3FO	3/8	5/8	50	30	Φ17×1.75
GUHD48NK3FO	3/8	5/8	50	30	Φ17×1.75
GUHD36NM3FO	3/8	5/8	30	15	Φ17×1.75
GUHD42NM3FO	3/8	5/8	50	30	Φ17×1.75
GUHD48NM3FO	3/8	5/8	50	30	Φ17×1.75
GUHD60NM3FO	3/8	3/4	50	30	Φ17×1.75

The connection pipe should be insulated with proper water-proof insulating material.

The pipe wall thickness shall be 0.5-1.0 mm and the pipe wall shall be able to withstand the pressure of 6.0 MPa. The longer the connecting pipe, the lower the cooling and heating effect performs.

4 ELECTRIC WIRING WORK

4.1 Wiring Precautions

 WARNING!
①. Before obtaining access to terminals, all supply circuits must be disconnected.
②. The rated voltage of the unit is as shown as Table 1-4-1 and Table 1-4-2
③. Before turning on, verify that the voltage is within the 198~264V range (for single phrase unit) or 342~457V range (for three-phrase unit).
④. Always use a special branch circuit and install a special receptacle to supply power to the air conditioner.
⑤. Use a special branch circuit breaker and receptacle matched to the capacity of the air conditioner.
⑥. The special branch circuit breaker is installed in the permanent wiring. Always use a circuit that can trip all the poles of the wiring and has an isolation distance of at least 3 mm between the contacts of each pole.
⑦. Perform wiring work in accordance with standards so that the air conditioner can be operated safely and positively.
⑧. Install a leakage special branch circuit breaker in accordance with the related laws and regulations and electric company standards.

 CAUTION!
①. The power source capacity must be the sum of the air conditioner current and the current of other electrical appliances. When the current contracted capacity is insufficient, change the contracted capacity.
②. When the voltage is low and the air conditioner is difficult to start, contact the power company to raise the voltage.

4.2 Electrical Wiring

(1) For solid core wiring (Figure 3-2-6)

- 1) Cut the wire end with a wire cutter or wire-cutting pliers, and then strip the insulation about 25 mm (15/16").
- 2) Using a screwdriver, remove the terminal screw(s) on the terminal board.
- 3) Using pliers, bend the solid wire to form a loop suitable for the terminal screw.
- 4) Shape the loop wire properly, place it on the terminal board and tighten securely with the terminal screw using a screwdriver.

(2) For strand wiring (Figure 3-2-6)

- 1) Cut the wire end with a wire cutter or wire-cutting pliers, and then strip the insulation about 10 mm (3/8").
- 2) Using a screwdriver, remove the terminal screw (s) on the terminal board.
- 3) Using a round terminal fastener or pliers, securely clamp a round terminal to each stripped wire end.
- 4) Position the round terminal wire, and replace and tighten the terminal screw with a screwdriver. (Figure 3-2-7)

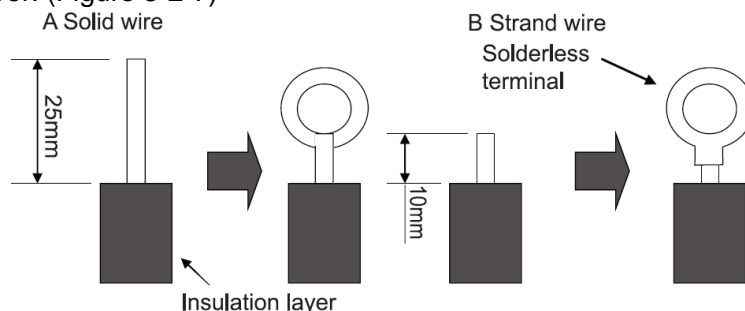

Figure 3-2-6

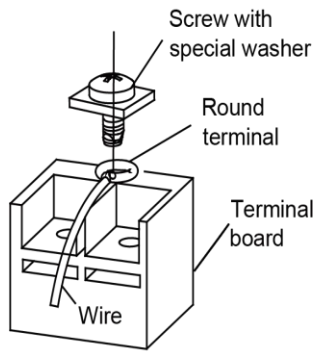

Figure 3-2-7

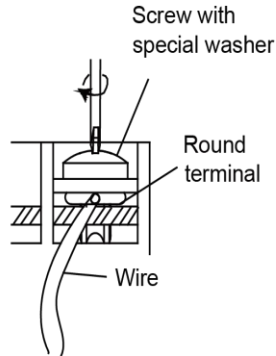
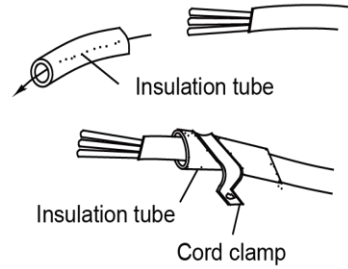



Figure 3-2-8



(3) How to fix connection cord and power cord by cord clamp

After passing the connection cord and power cord through the insulation tube, fasten it with the cord clamp. (Figure 3-2-8)

 WARNING!	
①	Before starting work, check that power is not being supplied to the indoor unit and outdoor unit.
②	Match the terminal block numbers and connection cord colors with those of the indoor unit side.
③	Erroneous wiring may cause burning of the electric parts.
④	Connect the connection cords firmly to the terminal block. Imperfect installation may cause a fire.
⑤	Always fasten the outside covering of the connection cord with cord clamps. (If the insulator is not clamped, electric leakage may occur.)
⑥	Always connect the ground wire.

(4) Electric wiring between the indoor and outdoor units

◆ Single-phase units (09k~30k)

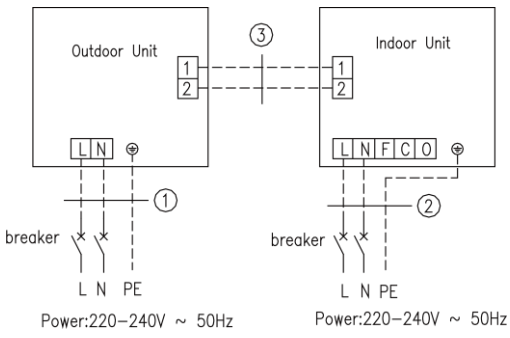
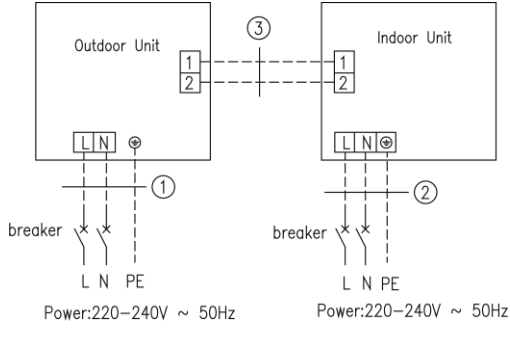
Duct Type Unit	Floor Ceiling
	
Cassete Type Unit	<p>GUHD09NK3FO + GFH09K3FI+ GTH09K3FI GUHD12NK3FO+ GFH12K3FI+ GTH12K3FI+ GKH12K3FI</p> <p>①. Power cord 3x1.0 mm²(H07RN-F) ②. Power cord 3x1.0 mm²(H05VV-F) ③. Communication Cords 2x0.75 mm² (H05VV-F)</p> <p>GUHD18NK3FO + GFH18K3FI+ GTH18K3FI+ GKH18K3FI</p> <p>①. Power cord 3x1.5 mm²(H07RN-F) ②. Power cord 3x1.0 mm²(H05VV-F) ③. Communication Cords 2x0.75 mm² (H05VV-F)</p> <p>GUHD24NK3FO + GFH24K3FI+ GTH24K3FI+ GKH24K3FI GUHD30NK3FO + GFH30K3FI+ GTH30K3FI+ GKH30K3FI</p> <p>①. Power cord 3x2.5 mm²(H07RN-F) ②. Power cord 3x1.0 mm²(H05VV-F) ③. Communication Cords 2x0.75 mm² (H05VV-F)</p>

◆ Single-phase units (36k~48k)

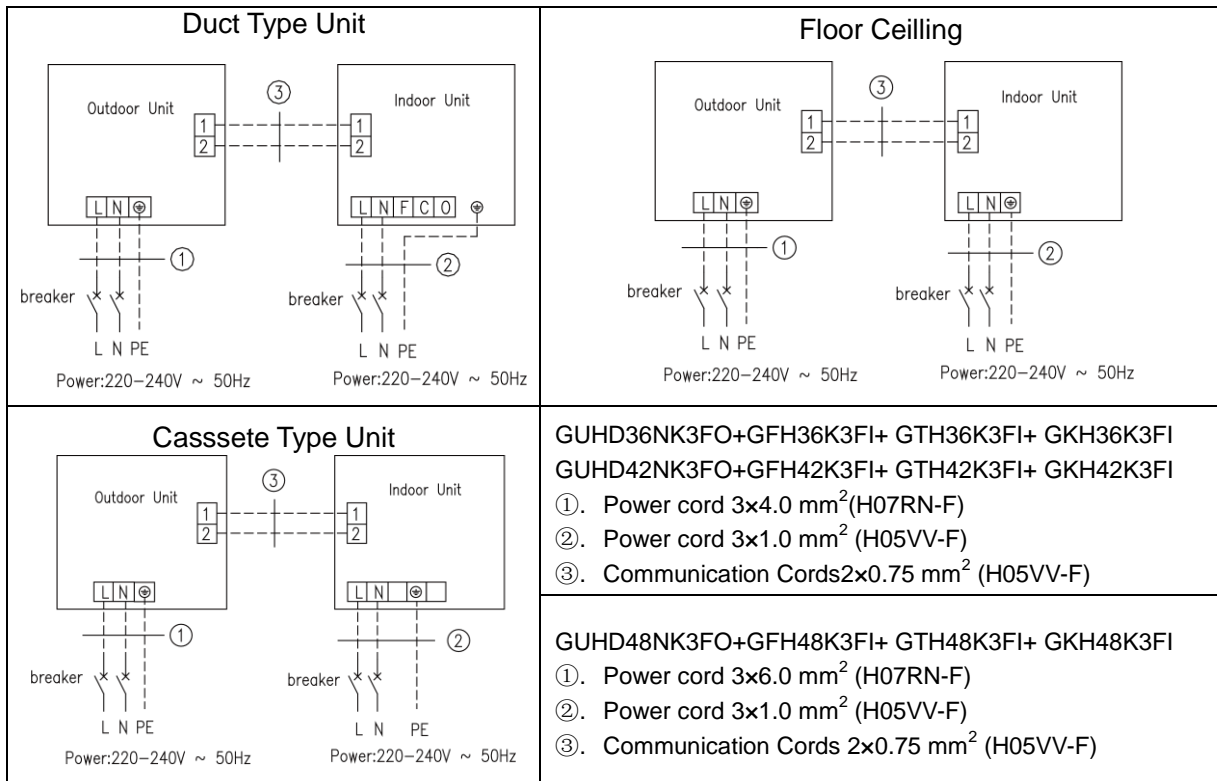

◆ Three-phase units

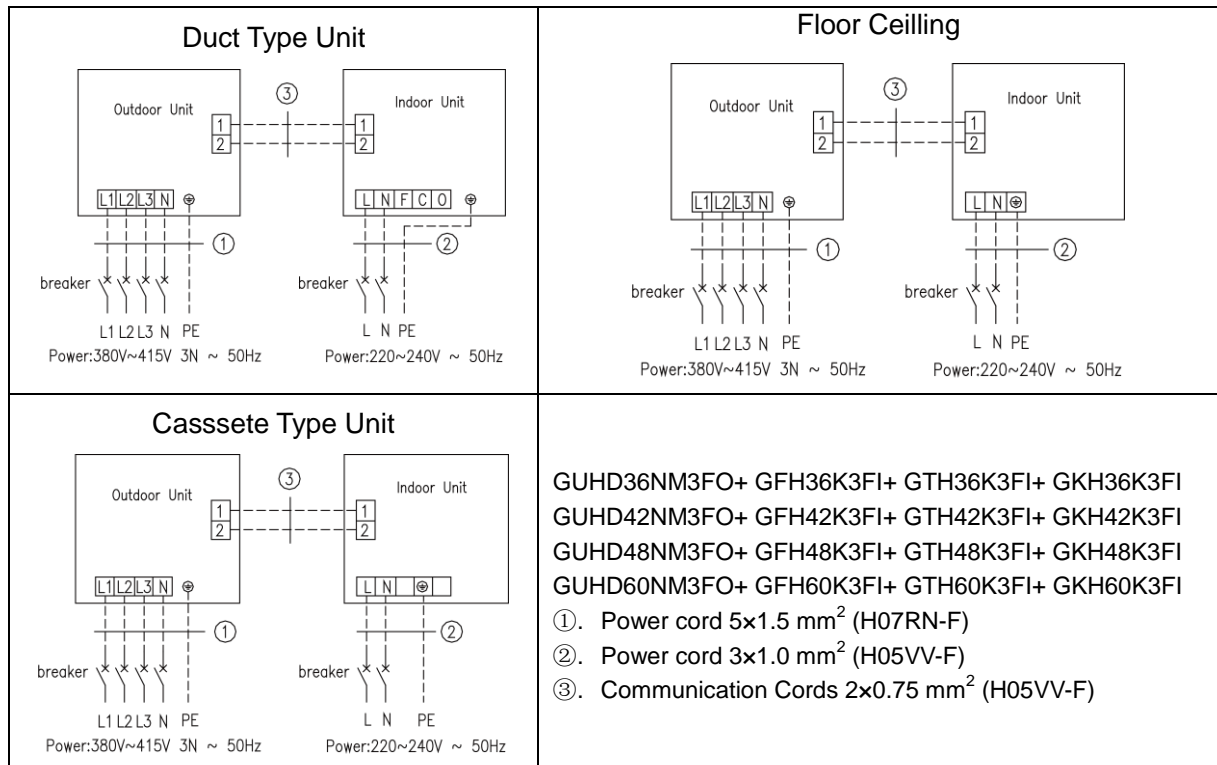

Figure 3-2-9

(5) Electric wiring of indoor unit side

Remove the electric box cover from the electric box sub-assy and then connect the wire.

◆ Duct Type Unit:

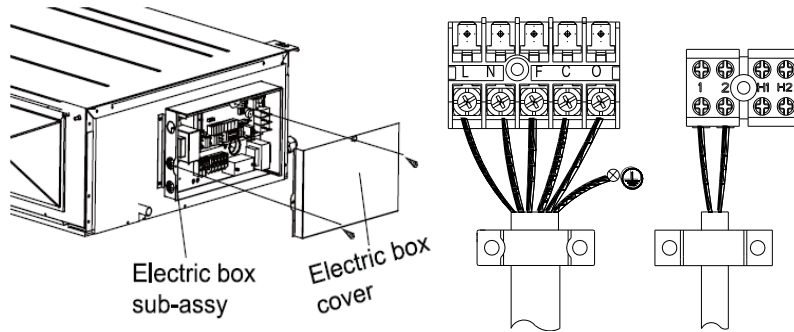

Figure 3-2-10

The F, C, O connect to the COMMOM, CLOSE and OPEN terminal of the fresh air valve respectively.

◆ Cassette Type Unit:

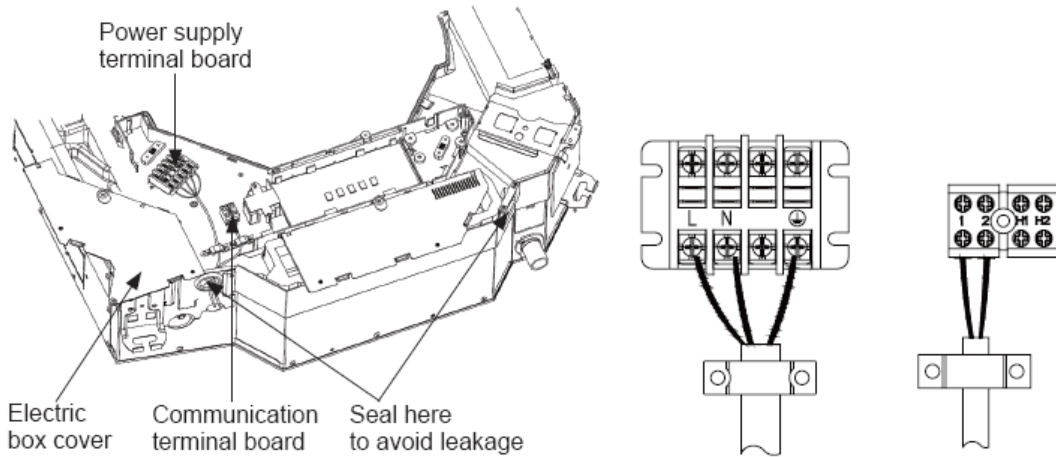

Figure 3-2-11

◆ Floor Ceiling Type Unit:

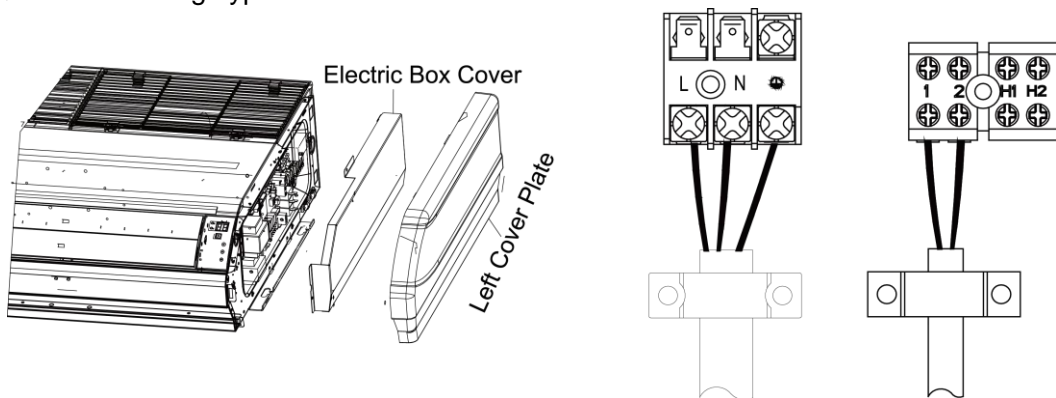

Figure 3-2-12



CAUTION!

- ①. The power cord and the wire of the fresh air valve are high-voltage, while the communication cord and connection wire of the wired controller are low-voltage. They should run separately against electromagnetic interference.
- ②. The high-voltage and low-voltage lines should pass through the rubber rings at different electric box covers.
- ③. Do not bundle the connection wire of the wired controller and the communication cord together, or arrange them in parallel, otherwise improper operation would occur.
- ④. The high-voltage and low-voltage lines should be fixed separately and securely, with internal big clamps for the former and small clamps for the latter.
- ⑤. Tighten the indoor/outdoor connection cord and power cord respectively on the terminal boards with screws. Faulty connection may cause a fire.
- ⑥. If the indoor unit connection cord (to the outdoor unit) and power supply are wired incorrectly, the air conditioner may be damaged.
- ⑦. Connect the indoor unit connection cord properly based on the corresponding marks as shown in Figure 3-2-9.
- ⑧. Ground both the indoor and outdoor units by attaching a ground wire.
- ⑨. Unit shall be grounded in compliance with the applicable local and national codes.

(6) Electric wiring of outdoor unit side

Note: When connecting the power supply cord, make sure that the phase of the power supply matches with the exact terminal board. If not, the compressor will rotate reversely and run improperly.

Remove the big handle (09~42k) /front board (48/60k) of the outdoor unit and insert the end of the communication cord and the power cable into the terminal board.

◆ Single phase:

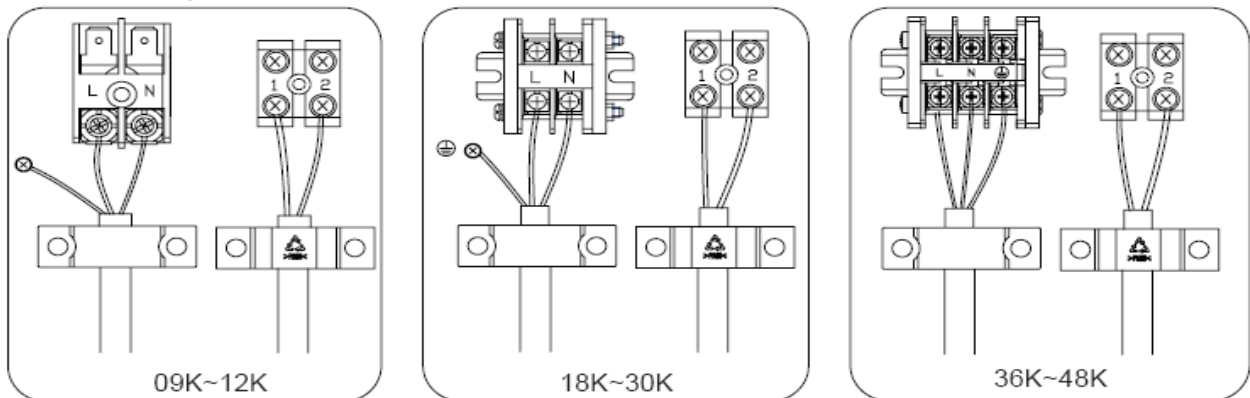

Figure 3-2-13

◆ Three-phase:

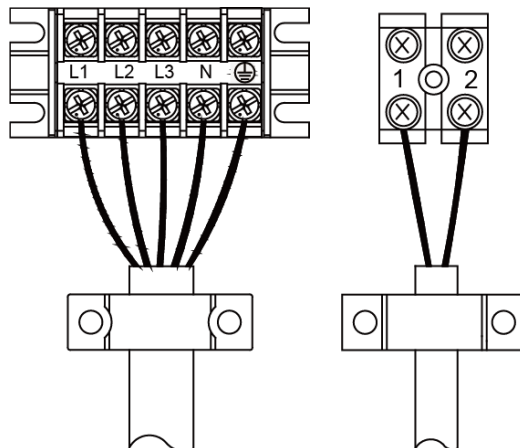

Figure 3-2-14

MAINTENANCE

MAINTENANCE

1 TROUBLE TABLE

1.1 Main Control Malfunction

Table 1 Fault Display on Indoor Wired Controller

No.	Error code	Malfunction name	Origin of malfunction signal	Control description
1	E1	High pressure protection	High pressure switch	When outdoor unit detects the high pressure switch is cut off for 3s successively, high pressure protection will occur. All the loads (except the 4-way valve in heating mode) will be switched off. In this case, all the buttons and remote control signals except ON/OFF button will be disabled and cannot be recovered automatically. Switch off the unit or re-energize the unit after cutting off power to eliminate this protection.
2	E2	Freeze protection	Indoor evaporator temperature sensor	If detecting that the evaporator temperature is lower than protective temp. Value after the unit has been running for a period of time under cooling or dry mode, the unit will report this fault, in which case the compressor and outdoor fan motor will be stopped. The unit will not run until evaporator temperature is higher than the protective temp. value and the compressor is stopped for 3min.
3	E3	Low pressure protection	Low pressure switch	If it is detected within 30s successively that the low-pressure switch is cut off under ON or standby state, the unit will report low pressure protection. If the fault occurs successively 3 times within 30min, the unit cannot be recovered automatically.
		Refrigerant lacking protection		If the unit reports system refrigerant lacking within 10min after turning on the unit, the unit will stop operation. If the fault occurs successively 3 times, the unit cannot be recovered automatically.
		Refrigerant recycling mode		If enter refrigerant recycling mode through special operation, E3 will be displayed. After exiting refrigerant recycling mode, the code will disappear.
4	E4	Compressor high discharge temperature protection	Compressor discharge temperature is high	If outdoor unit detects that the discharge temperature is higher than protective temp. Value, the unit will report high discharge temperature protection. If the protection occurs over 6 times, the unit cannot be recovered automatically. Switch off the unit or re-energize the unit after cutting off power to eliminate this protection.
6	E6	Communication malfunction	Communication between indoor and outdoor mainboard	If the outdoor unit does not receive data from indoor unit, communication malfunction will be reported. If there is communication abnormality between display board and indoor unit, communication malfunction will be reported too.
8	E8	Malfunction of indoor fan motor	Indoor fan motor	If the indoor unit does not receive signal from indoor fan motor for 30s successively when the fan motor is operating, indoor fan motor malfunction will be reported. In this case, the unit can automatically resume operation after stopping. If the malfunction occurs 6 times within one hour, the unit cannot be recovered automatically. Switch off the unit or re-energize the unit after cutting off power to eliminate this malfunction.
9	E9	Full water protection	Water level switch	If cut-off of water level switch is detected for 8s successively once energized, the system will enter full water protection. In this case, switch off the unit and then switch it on to eliminate this malfunction.
10	F0	Malfunction of indoor ambient temperature sensor at air return port	Indoor ambient temperature sensor	If the indoor ambient temperature sensor is detected of open circuit or short circuit for 5s successively, indoor ambient temperature sensor malfunction will be reported. The unit can automatically resume operation after the malfunction disappears. If indoor ambient temperature sensor malfunction occurs in fan mode, only the error code is displayed and the indoor unit can work normally.
11	F1	Malfunction of evaporator temperature sensor	Evaporator temperature sensor	If the indoor evaporator temperature sensor is detected of open circuit or short circuit for 5s successively, evaporator temperature sensor malfunction will be reported. The unit can automatically resume operation after the malfunction disappears. If evaporator temperature sensor malfunction occurs in fan mode, only the error code is displayed and the indoor unit can work normally.

No.	Error code	Malfunction name	Origin of malfunction signal	Control description
12	F2	Malfunction of condenser temperature sensor	Condenser temperature sensor	If the outdoor condenser temperature sensor is detected of open circuit or short circuit for 5s successively, condenser temperature sensor malfunction will be reported. The unit can automatically resume operation after the malfunction disappears. If condenser temperature sensor malfunction occurs in fan mode, only the error code is displayed and the indoor unit can work normally.
13	F3	Malfunction of outdoor ambient temperature sensor	Outdoor ambient temperature sensor	If the outdoor ambient temperature sensor is detected of open circuit or short circuit for 5s successively, outdoor ambient temperature sensor malfunction will be reported. The unit can automatically resume operation after the malfunction disappears. If outdoor ambient temperature sensor malfunction occurs in fan mode, only the error code is displayed and the indoor unit can work normally.
14	F4	Malfunction of discharge temperature sensor	Discharge temperature sensor	If the outdoor discharge temperature sensor is detected of open circuit or short circuit for 5s successively after the compressor has been operating for 3min, outdoor discharge temperature sensor malfunction will be reported. The unit can automatically resume operation after the malfunction disappears.
15	F5	Malfunction wired controller temperature sensor	Wired controller	If the wired controller detects open circuit or short circuit of its temperature sensor for 5s successively, wired controller temperature sensor malfunction will be reported.
18	ee	Malfunction of outdoor drive memory chip	Outdoor drive board	If the memory chip of outdoor drive board is broken, the unit cannot be started. The unit cannot be recovered automatically. If the malfunction cannot be eliminated after switching off the unit and then energizing the unit for several times, please replace the outdoor drive board.
20	H3	Compressor overload protection	Compressor overload switch	If it is detected within 3s successively that the overload switch is cut off under ON or standby state, the unit will report overload protection. If the fault occurs successively 3 times, the unit cannot be recovered automatically. Switch off the unit or re-energize the unit after cutting off power to eliminate this protection.
21	H4	Overload protection	Evaporator temperature, condenser temperature	If outdoor unit detects that the tube temperature is higher than protective temp. Value, the unit will report overload protection. The unit will not restart operation until tube temperature is lower than the protective temp. Value and the compressor is stopped for 3min. If the protection occurs over 6 times, the unit cannot be recovered automatically. Switch off the unit or re-energize the unit after cutting off power to eliminate this protection.
23	H6	Malfunction of outdoor fan motor	Outdoor fan motor	If the outdoor unit does not receive signal from outdoor fan motor for 30s successively when the fan motor is operating, outdoor fan motor malfunction will be reported. In this case, the unit can automatically resume operation after stopping. If the malfunction occurs 6 times within one hour, the unit cannot be recovered automatically. Switch off the unit or re-energize the unit after cutting off power to eliminate this malfunction.
32	U7	Direction changing malfunction of 4-way valve	4-way valve	After the compressor starts operation in heating mode, if the outdoor unit detects the difference between evaporator temperature and indoor ambient temperature is lower than the protective value for 10min successively, direction changing malfunction of 4-way valve will be reported and the outdoor unit will stop operation. The unit can automatically resume operation in the first two malfunctions. If the malfunction occurs 3 times, the unit cannot be recovered automatically. Switch off the unit or re-energize the unit after cutting off power to eliminate this malfunction.
35	P6	Communication malfunction between main control and drive	Communication between main control board and drive board	If the outdoor main control board does not receive data from drive board, communication malfunction between main control and drive will be reported. This malfunction can be eliminated automatically.
47	EE	Malfunction of outdoor main control memory chip	Outdoor main control board	If the memory chip of outdoor main control board is broken, the unit cannot be started. The unit cannot be recovered automatically. If the malfunction cannot be eliminated after switching off the unit and then energizing the unit for several times, please replace the outdoor main control board.

No.	Error code	Malfunction name	Origin of malfunction signal	Control description
48	CC	Long-distance monitor or centralized controller has set the shielding function	long-distance monitor or centralized controller	When the unit is connected to long-distance monitor or centralized controller, shielding function (including ON/OFF setting for shielding function, temperature setting for shielding function, SE setting for shielding function or all lock setting) can be set through long-distance monitor or centralized controller. When all lock is set, "cc" code will be always displayed on the indoor unit. When setting other shielding function, "CC" code will be displayed for 1s after receiving the remote control signal. This is the normal function for the unit. After cancel shielding function through long-distance monitor or centralized controller, this code will disappear automatically.

1.2 Description of Drive Malfunction

Main board dual 8 numeral tube Display Codes for Outdoor Unit of 09~48k

Malfunction Item	Indoor Unit Display	Outdoor unit display of dual 8 numeral tube
DC busbar over-voltage protection	PH	PH
IPM or PFC over-temperature protection	P8	P8
Current sense circuit error	Pc	Pc
IPM or PFC temperature sensor error	P7	P7
Compressor current protection	P5	P5
DC busbar under-voltage protection	PL	PL
Compressor startup failure	Lc	Lc
Drive module reset	P0	P0
Compressor motor desynchronizing	H7	H7
Phase loss	Ld	Ld
Drive-to-main-control communication error	P6	P6
IPM protection	H5	H5
Compressor overload protection	H3	H3
AC current protection (input side)	PA	PA
Charging circuit error	PU	PU
PFC protection	HC(48k only)	HC(48k only)
DC fan error	H6	H6
Input AC voltage abnormality	PP	PP
Driving board memory chip error	ee(09-42k)	ee(09-42k)

2 FLOW CHART OF TROUBLESHOOTING

2.1 Troubleshooting Flow Chart of Main Control Malfunction

◆ E1 High Pressure Protection

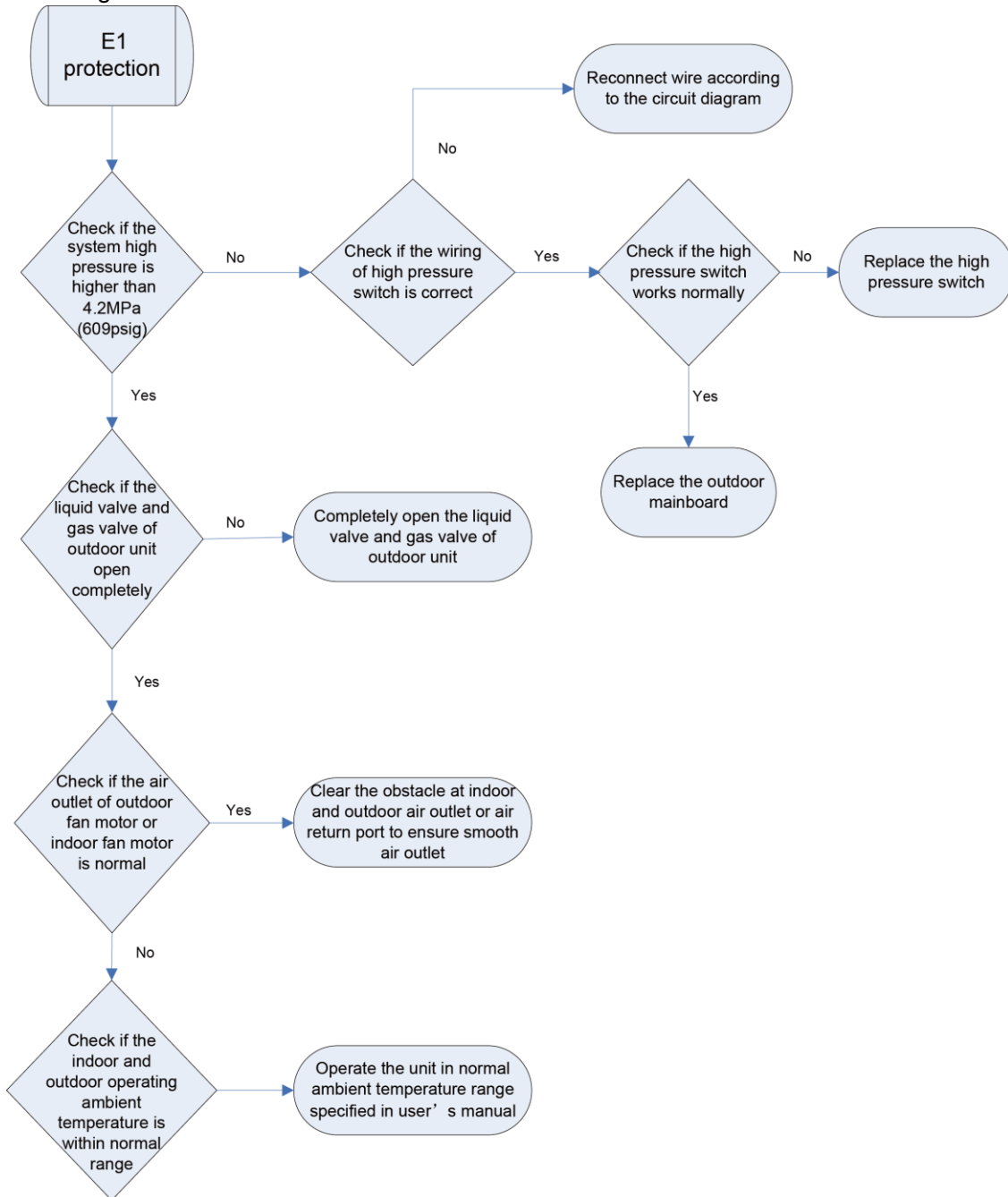

◆ E2 Freeze Protection

Freeze protection is normal protection but not abnormal malfunction. If freeze protection occurs frequently during operation, please check if the indoor filter is with filth blockage or if the indoor air outlet is abnormal. The user is required to clean the filter, check the air outlet and air return pipe periodically to ensure smooth air return and air outlet.

◆ E3 stands for three statuses:

- (1) Low pressure protection (48k/60k);
- (2) Refrigerant lacking protection;
- (3) Refrigerant recycling mode;

- ① If enter refrigerant recycling mode through special operation, the displayed E3 is not an error code. It will be eliminated when exiting refrigerant recycling mode.
- ② If you do not want to have refrigerant lacking protection, you can enter the debugging mode through wired controller and then cancel the refrigerant lacking protection mode.

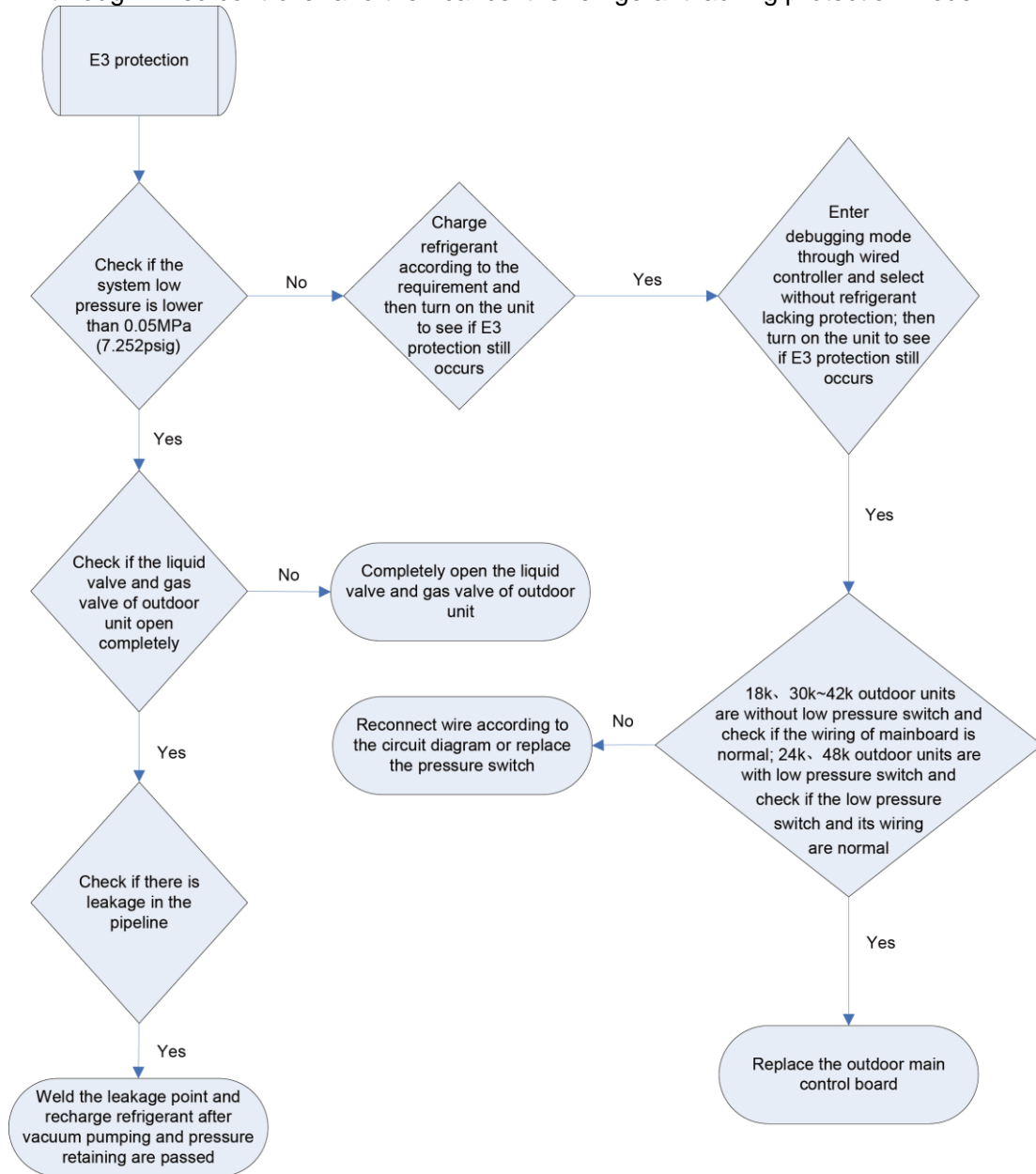

◆ E4 Discharge Protection

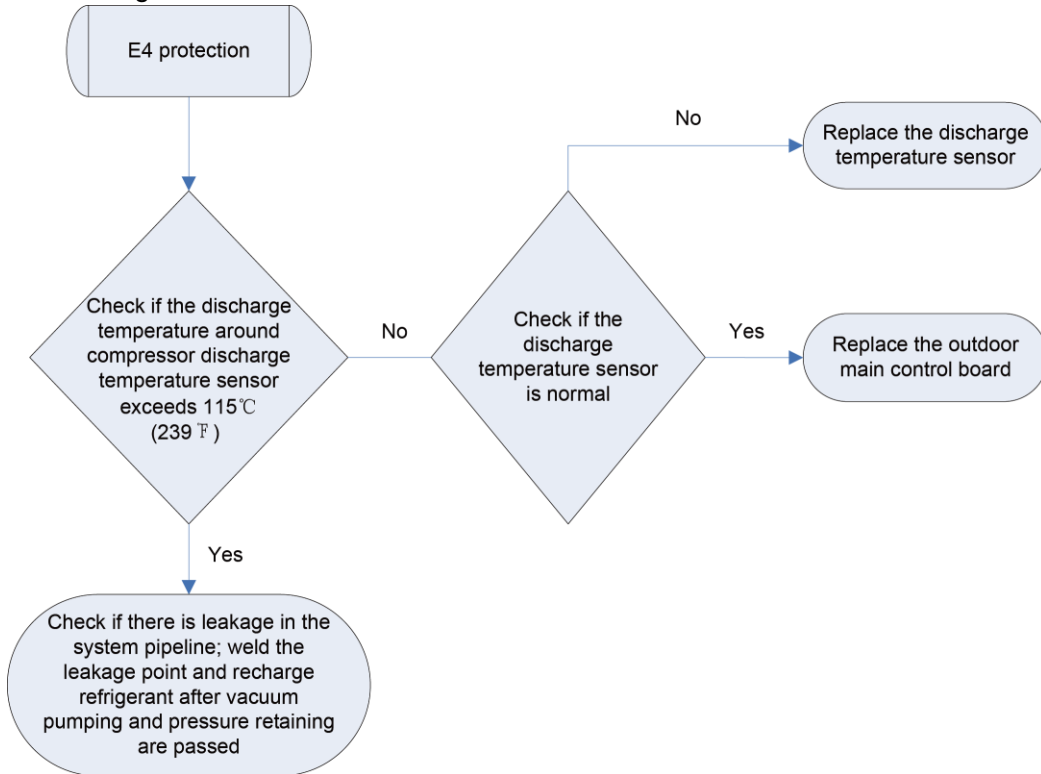

◆ E6 Communication Malfunction

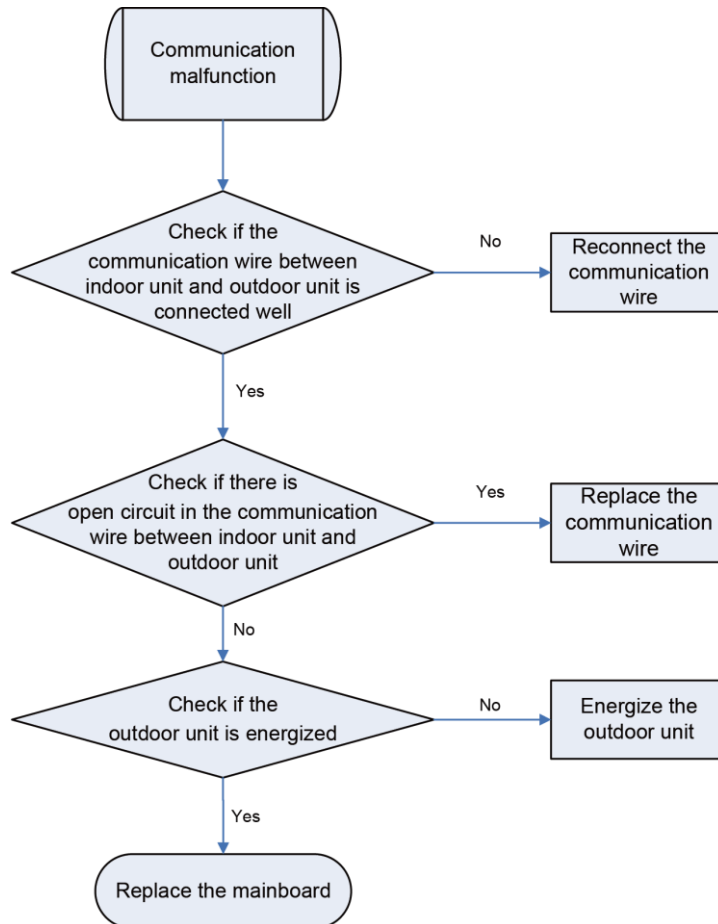

◆ E9 Full Water Protection

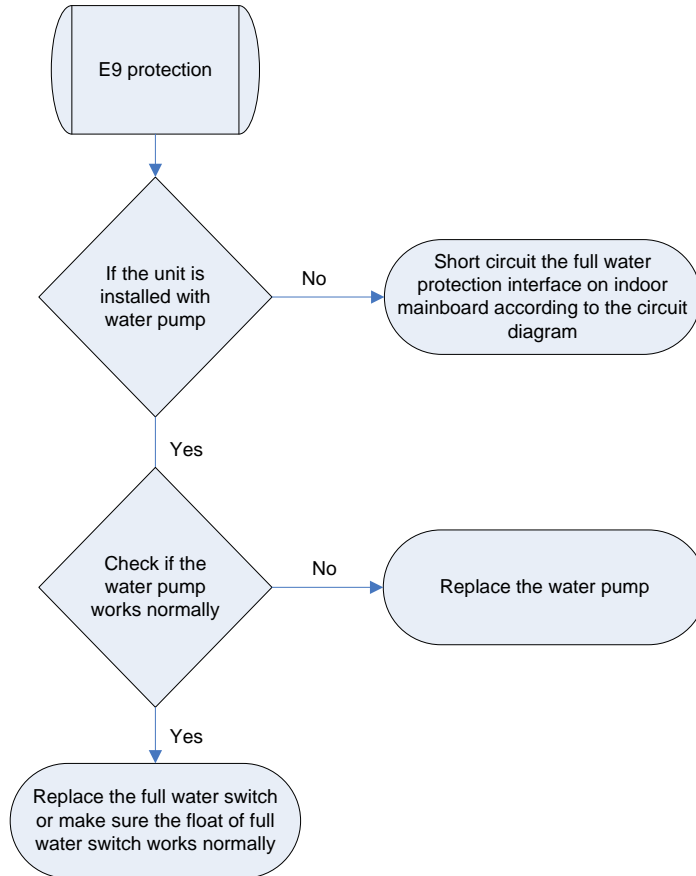

◆ F0 Malfunction of Indoor Ambient Temperature Sensor

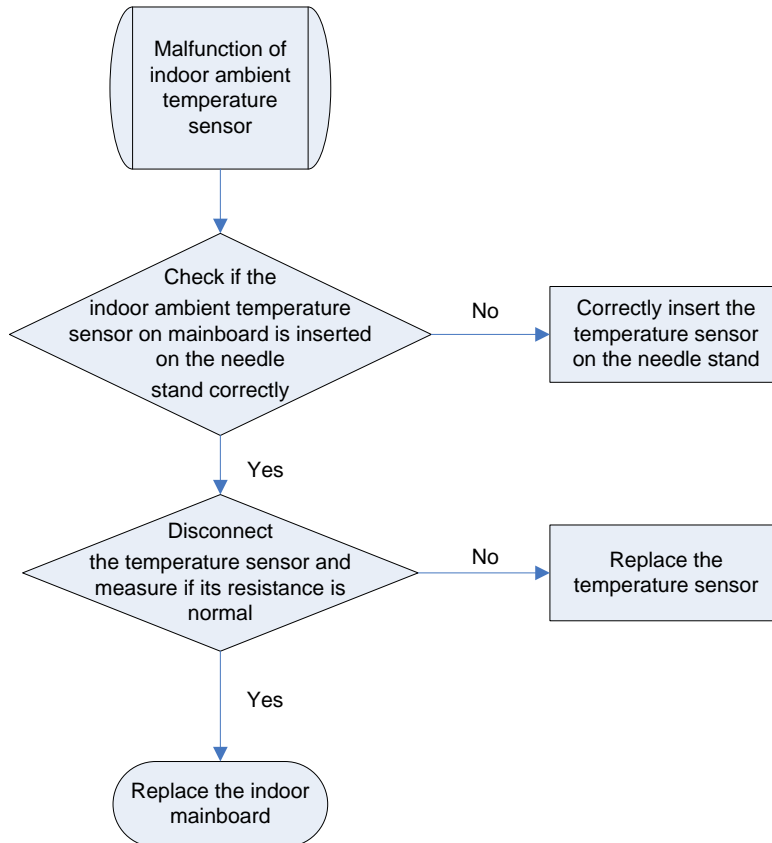

◆ F1 Malfunction of Evaporator Temperature Sensor

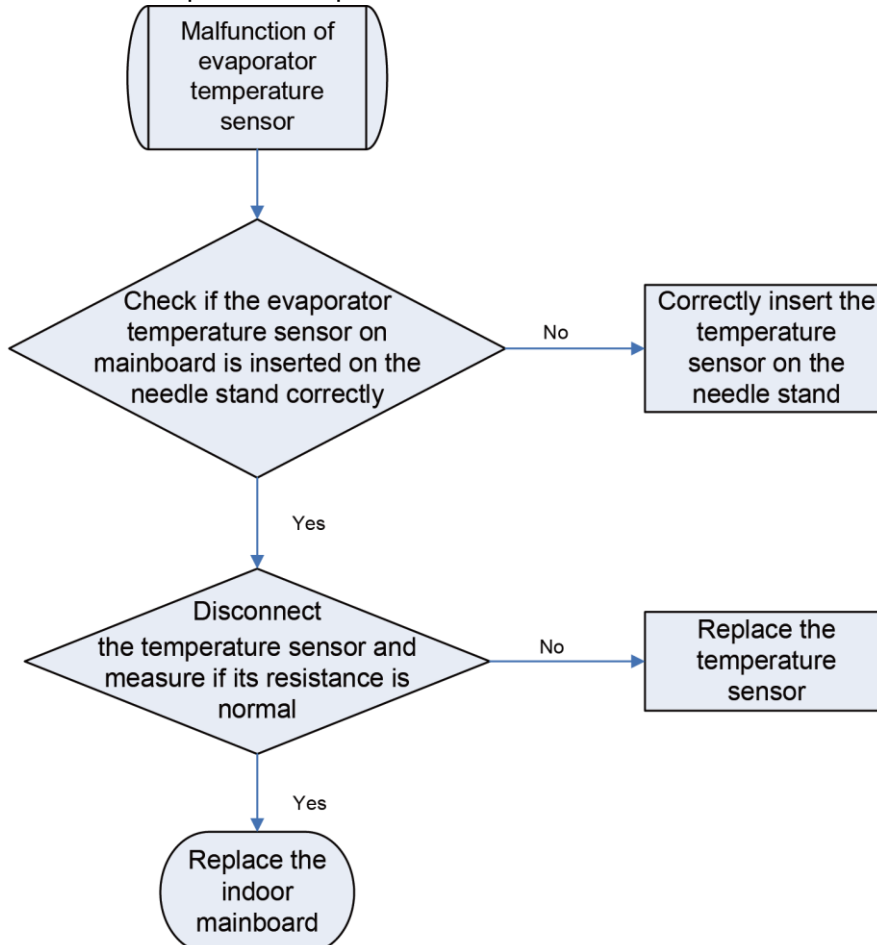

◆ F2 Malfunction of Condenser Temperature Sensor

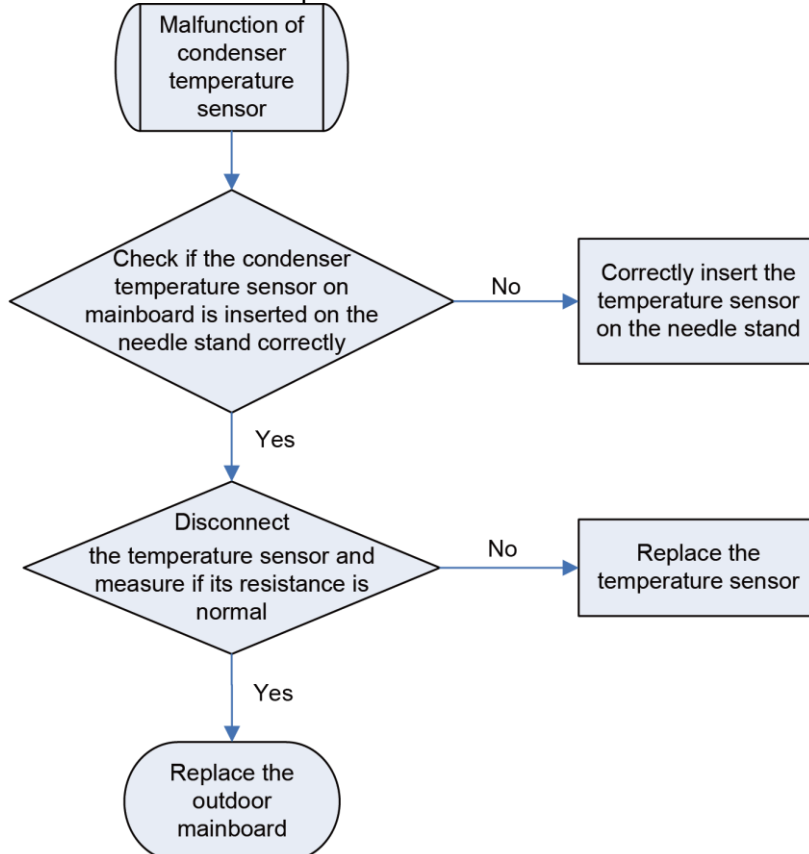

◆ F3 Malfunction of Outdoor Ambient Temperature Sensor

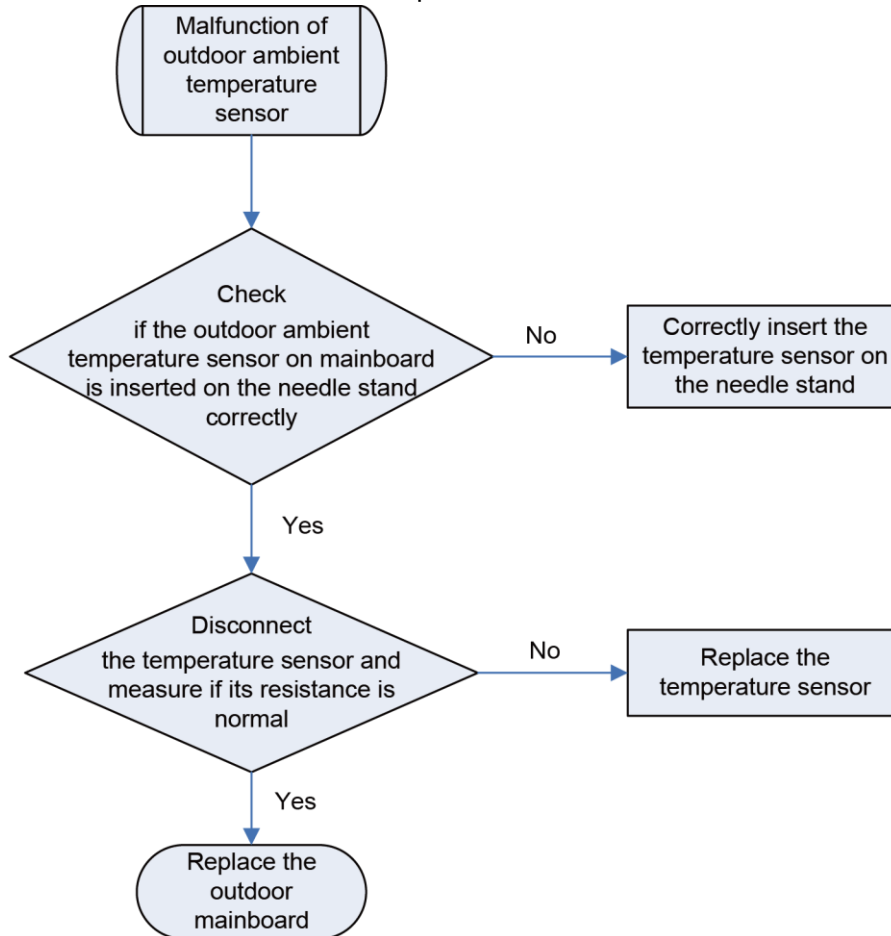

◆ F4 Malfunction of Discharge Temperature Sensor

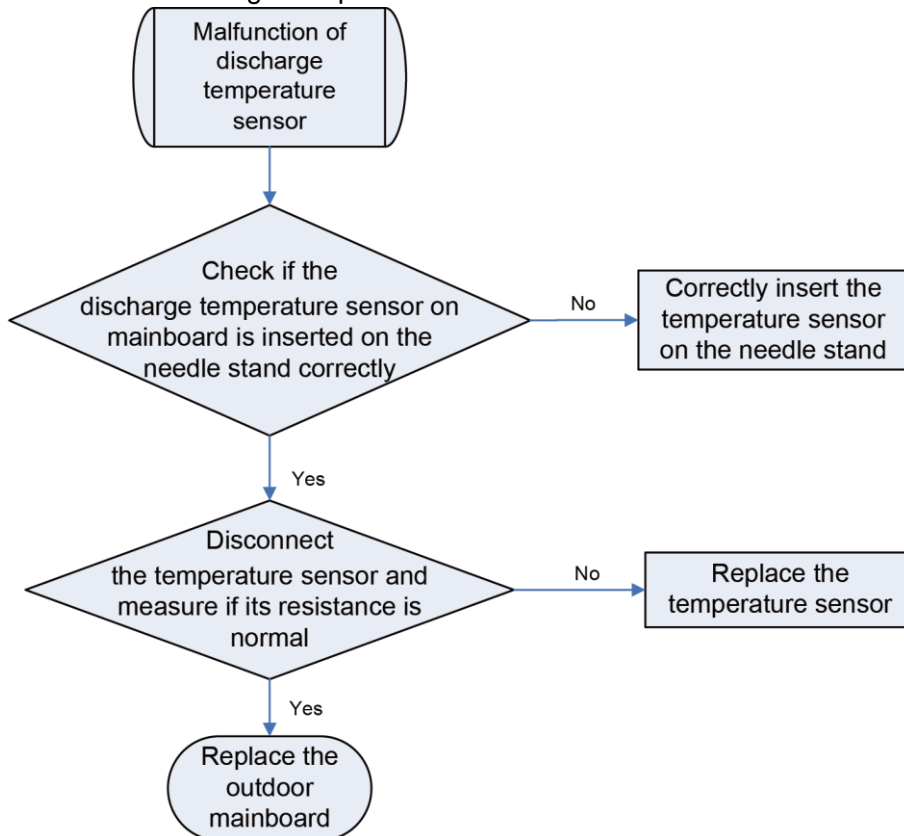

◆ F5 Malfunction of Wired Controller Temperature Sensor

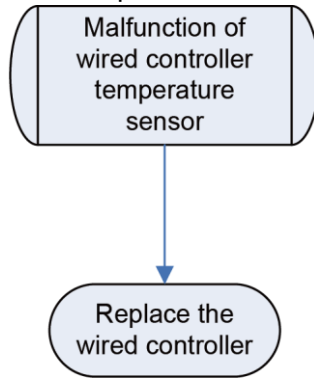

◆ H6 Malfunction of Outdoor Fan Motor

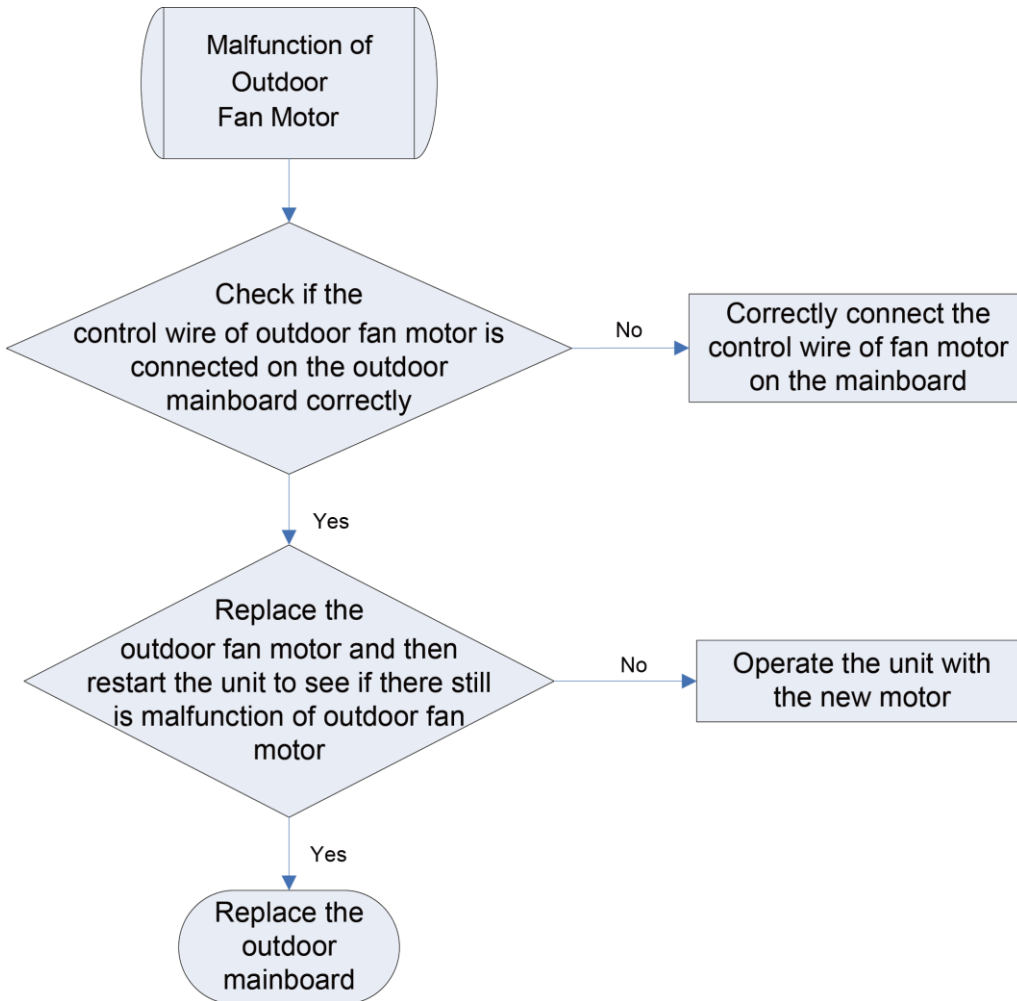

◆ E8 Malfunction of Indoor Fan Motor

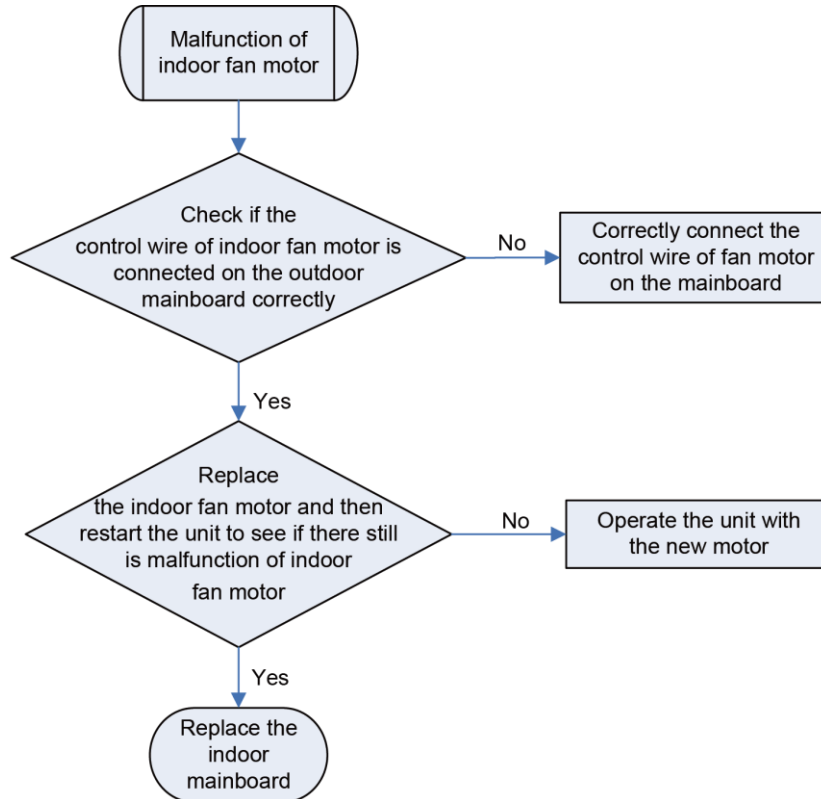

2.2 Troubleshooting Flow Chart of Drive Malfunction

Note: For Outdoor Unit Drive (Inverter) by Single-phase Motor

(Applicable to GUHD09NK3FO/GUHD12NK3FO/GUHD18NK3FO/GUHD24NK3FO /GUHD30NK3FO/GUHD36NK3FO/GUHD42NK3FO/GUHD48NK3FO/GUHD36NM3FO /GUHD42NM3FO/ GUHD48NM3FO/GUHD60NM3FO)

- ◆ P0 Drive module reset
- ◆ P7 IPM or PFC temperature sensor error
- ◆ PA AC current protection (input side)
- ◆ PC Current sense circuit error
- ◆ HC PFC protection (48k only)

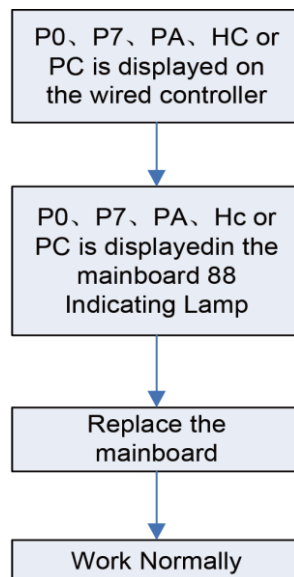

◆ P8 IPM or PFC over-temperature protection

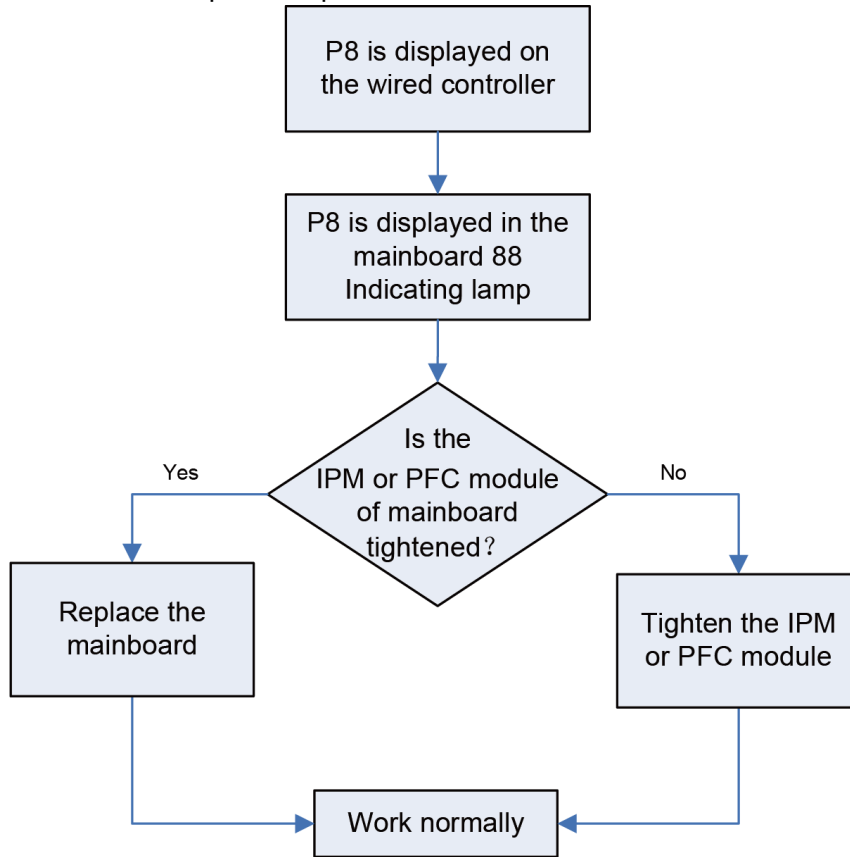

◆ PH DC busbar over-voltage protection

◆ PL DC busbar under-voltage protection

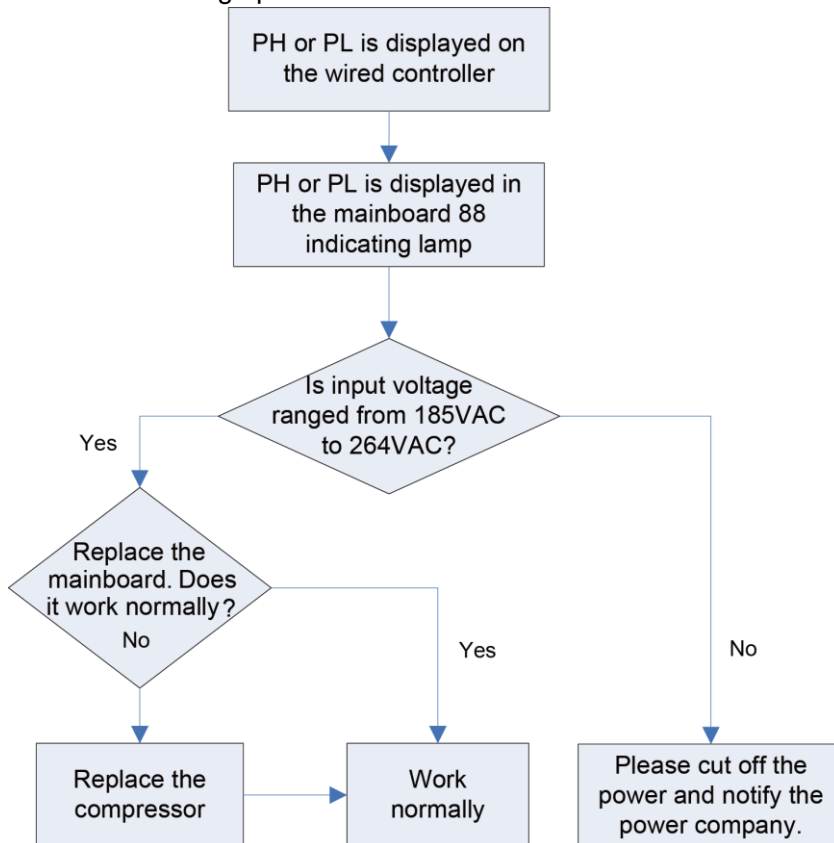

- ◆ P6 Drive-to-main-control communication error
- ◆ Lc Compressor Startup Failure

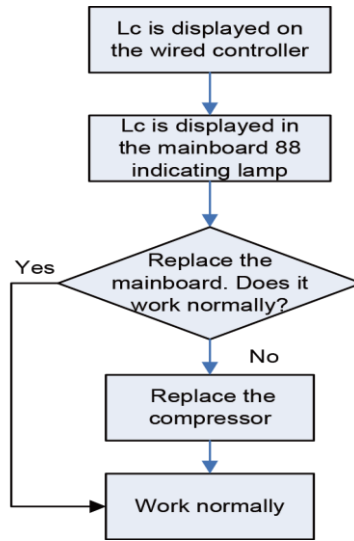

- ◆ P5 Compressor current protection
- ◆ H7 Compressor motor desynchronizing
- ◆ H5 IPM protection
- ◆ Ld Phase loss

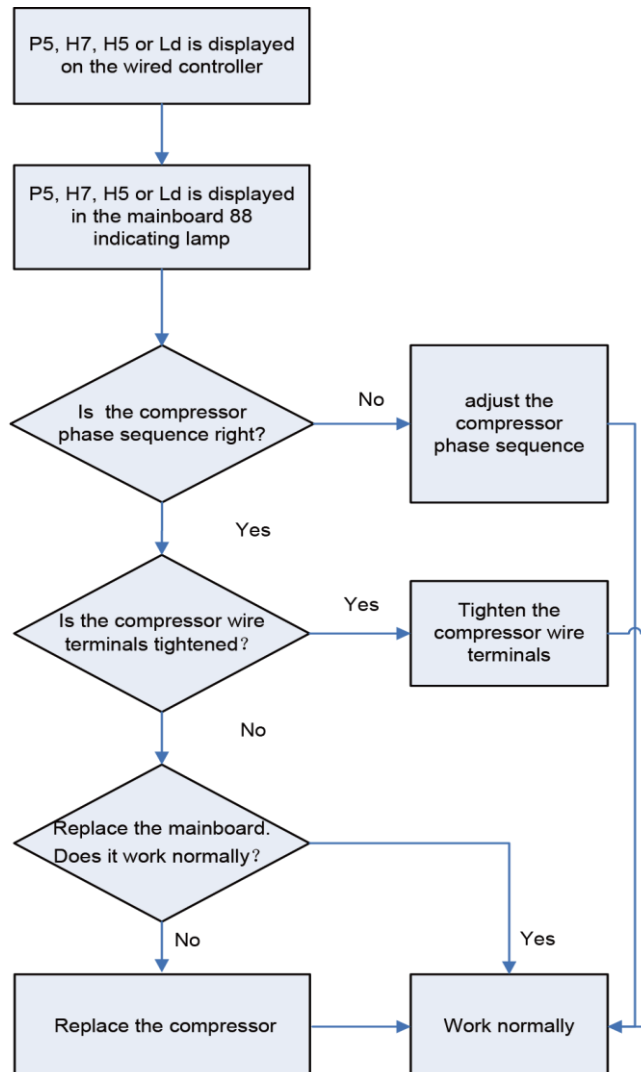

◆ PU Charging circuit error

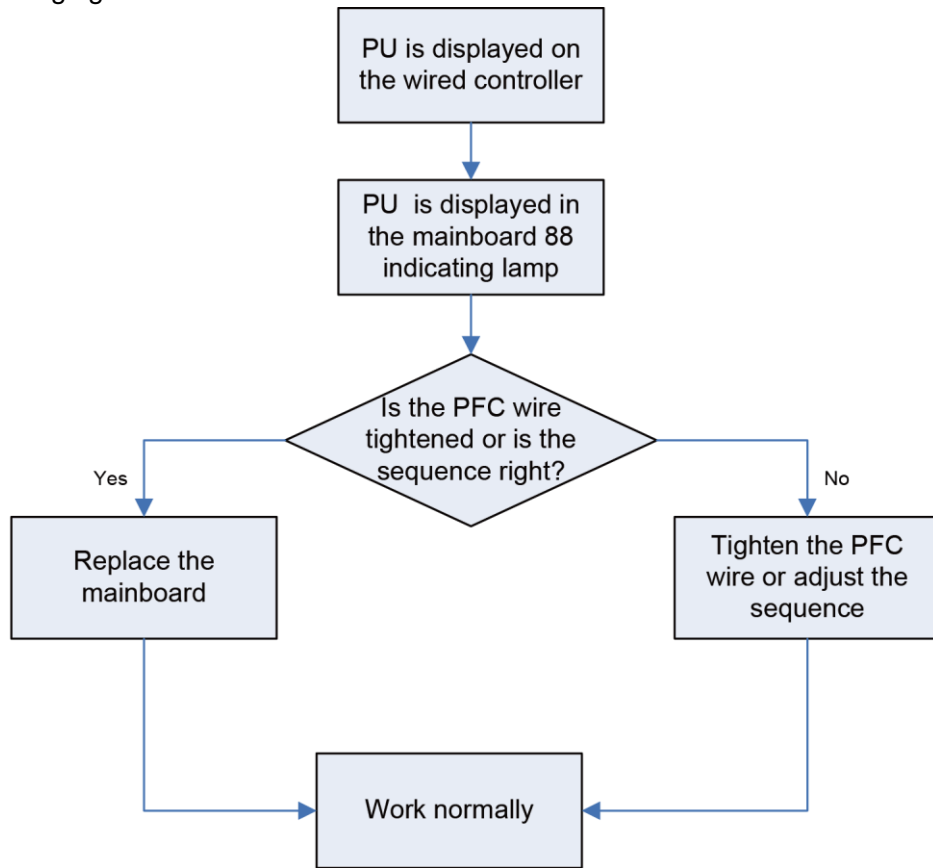

◆ ee driving board chip error

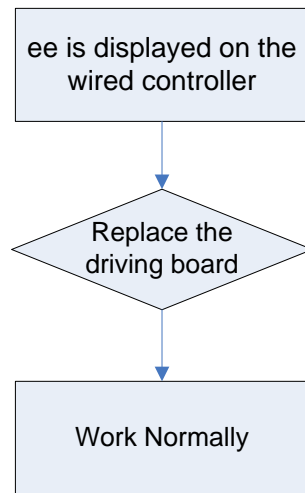

◆ H6 DC fan error

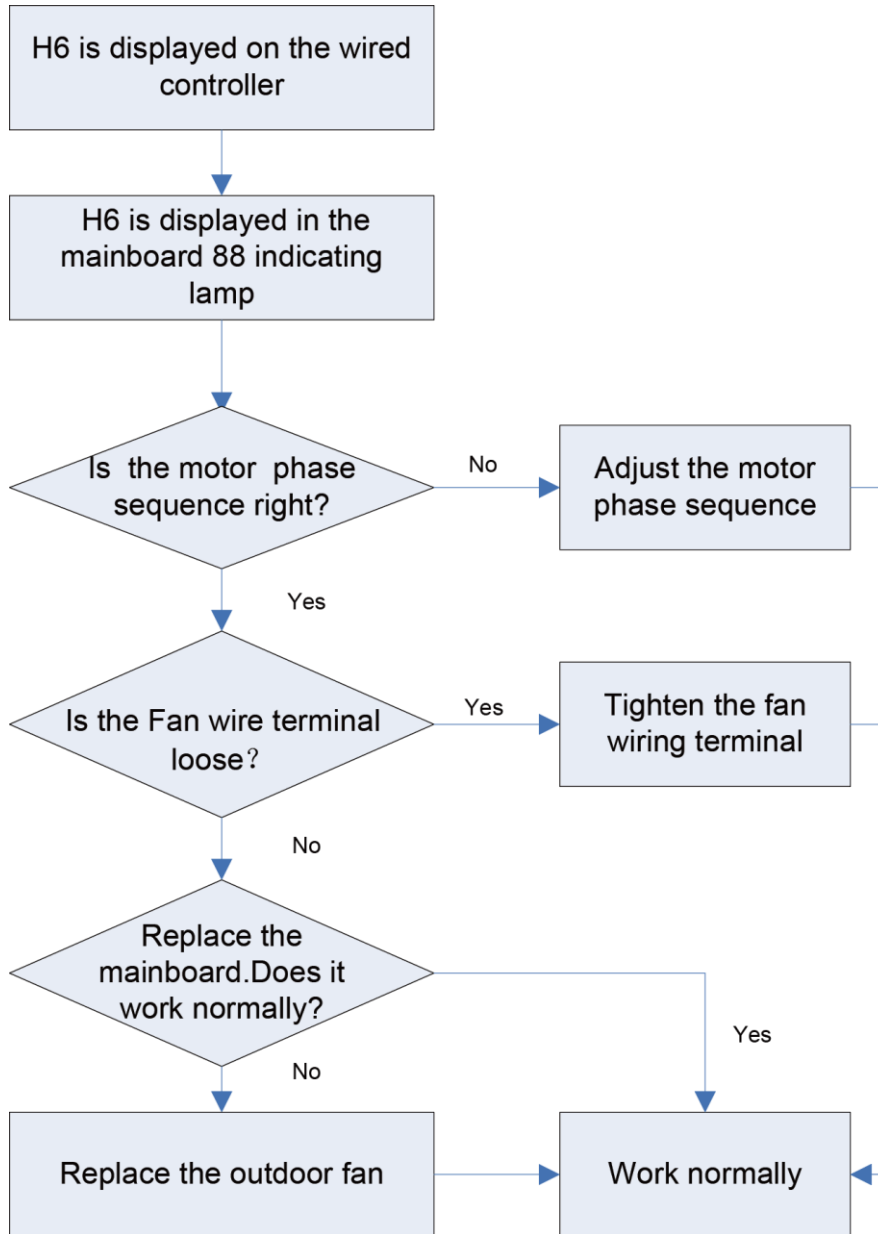

2.3 Interface

◆ GUHD09NK3FO/GUHD12NK3FO Main Control board

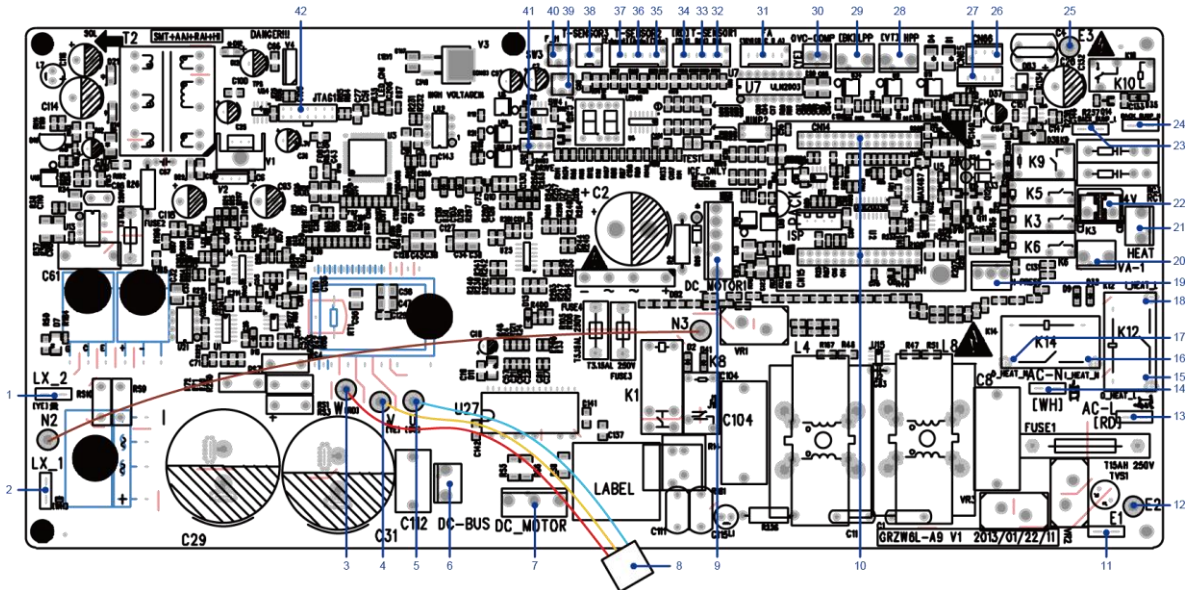

No.	Printing	Interface	No.	Printing	Interface
1	LX_2	PFC reactor wire (yellow)	2	LX_1	PFC reactor wire (white)
3	W	Compressor Phase W	4	V	Compressor Phase V
5	U	Compressor Phase U	6	DC-BUS	(Reserved)
7	DC_MOTOR	(Reserved)	8	-	Compressor interface
9	DC-MOTOR1	Interface of outdoor fan motor	10	CN14/CN15	Interface of CPU board
11	E1	(Reserved)	12	E2	Grounding wire (yellow-green lead-out wire)
13	AC-L	Live wire input (red)	14	AC-N	Neutral wire input (white)
15	O_HEAT_L	(Reserved)	16	I_HEAT_N	(Reserved)
17	O_HEAT_N	(Reserved)	18	I_HEAT_L	(Reserved)
19	H-PRESS	Pressure switch	20	VA-1	Chassis electric heating belt
21	HEAT	Compressor electric heating belt	22	4V	4-way valve
23	BACK_BUMP_L	(Reserved)	24	BACK_BUMP_N	(Reserved)
25	E3	Grounding wire (yellow-green lead-out wire)	26	CN66	Communication interface between indoor unit and outdoor unit
27	CN65	(Reserved)	28	HPP	High pressure switch (reserved)
29	LPP	Low pressure switch (reserved)	30	OVC-COMP	Compressor overload switch
31	FA	Electronic expansion valve	32	T-SENSOR1(In)	(Reserved)
33	T-SENSOR1(Mid)	(Reserved)	34	T-SENSOR1(Out)	(Reserved)
35	T-SENSOR2(Tube)	Tube temperature sensor	36	T-SENSOR2(Ambi)	Ambient temperature sensor
37	T-SENSOR2(Exhaust)	Discharge temperature sensor	38	T-SENSOR3	(Reserved)
39	SW4	(Reserved)	40	SW3	(Reserved)
41	A-DRIVE	(Reserved)	42	JTAG1	(Reserved)

◆ GUHD18NK3FO/GUHD24NK3FO/GUHD30NK3FO/GUHD36NK3FO/GUHD42NK3FO /GUHD48NK3FO/GUHD36NM3FO/GUHD42NM3FO/GUHD48NM3FO/GUHD60NM3FO Main Control Board

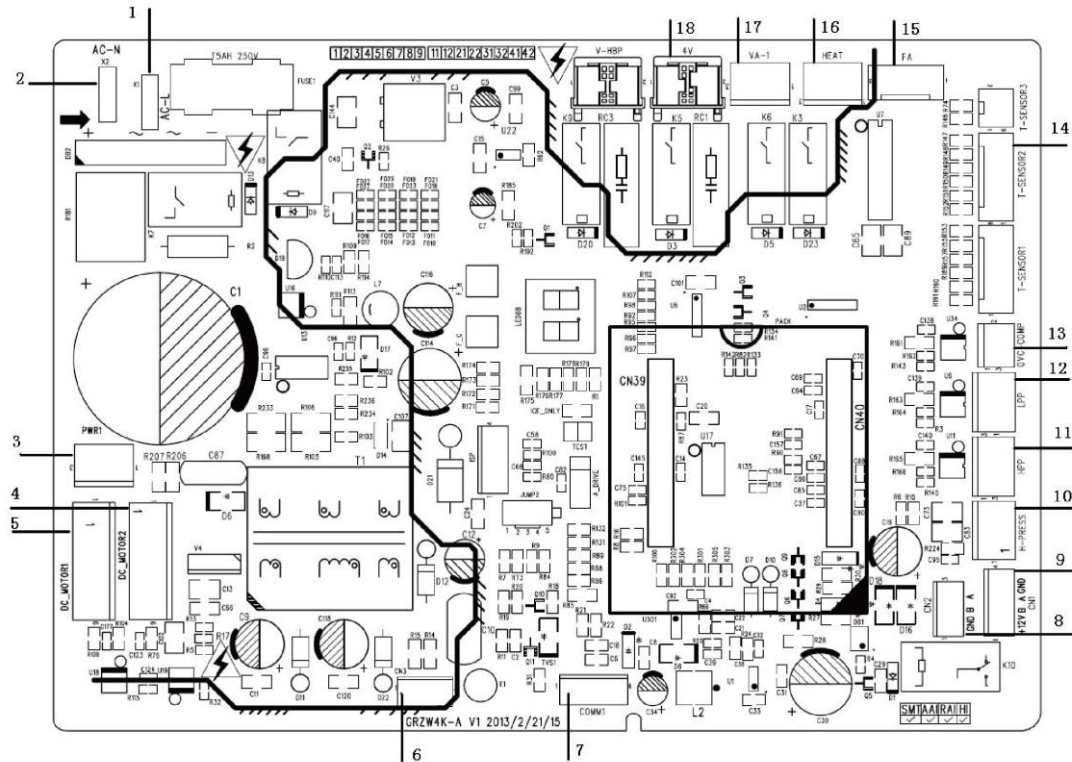

NO.	SILK-SCREEN	INTERFACE	INTERFACE INSTRUCTION
1	AC-L	Live wire input	Live wire input
2	AC-N	Neutral wire input	Neutral wire input
3	PWR 1	Control power output[1- DC bus voltage,3- GND]	Power supply interface to the drive 1-pin: DC bus voltage 3-pin: DC bus GND
4	DC_MOTOR2	DC fan motor2 1-pin: Power supply of fan motor 3-pin: Fan GND 4-pin: +15V 5-pin: Signal control 6-pin: NC	Interface of DC fan motor 1-pin: DC bus voltage 2-pin: Suspended 3-pin: DC bus GND 4-pin: +15V 5-pin: Control signal input 6-pin: Not connected
5	DC_MOTOR1	DC fan motor1 1-pin: Power supply of fan motor 3-pin: Fan GND 4-pin: +15V 5-pin: Signal control 6-pin: Signal Feedback	Interface of DC fan motor 1-pin: DC bus voltage 2-pin: Suspended 3-pin: DC bus GND 4-pin: +15V 5-pin: Control signal input 6-pin: DC fan motor feedback
6	CN3	Control power output[1-GND、 2-18V、 3-15V]	Power supply interface to the drive 1-pin: GND 2-pin: +18V 3-pin: +15V
7	COMM1	Communication line [1-3.3V、 2-TX、 3-RX、 4-GND]	Communication needle stand of main control drive 1-pin: +3.3V, 2-pin: TXD 3-pin: RXD, 4-pin: GND
8	CN2	Communication line with 1-pin GND, 2-pin B and 3-pin A)	Communication needle stand with indoor unit 1-pin: GND, 2-pin: B, 3-pin: A
9	CN1	Communication line with 1-pin plus 12V, 2-pin B, 3-pin A and 4-pin GND	Communication interface (reserved): 1-pin: +12V, 2-pin: B, 3-pin: A, 4-pin: GND

10	H-PRESS	High pressure switch for fan speed adjustment	Pressure protection switch for fan speed adjustment
11	HPP	High pressure switch for system protection(obligate)	Interface of high pressure protection
12	LPP	Low pressure switch for system protection (obligate)	Interface of low pressure protection
13	OVC-COMP	Compressor overload protection	Interface of compressor overload protection
14	T-SENSOR2	1&2 pin: Tube sensor 3&4 pin: Ambient temperature 5&6 pin: Air discharge	1&2 pin: Case temperature sensor 3&4 pin: Ambient temperature sensor 5&6 pin: Discharge temperature sensor
15	FA	Electronic expansion valve line 1 to 4-pin: Drive impulse output;5-pin: +12V;	Interface of electronic expansion valve: 1 to 4-pin: Drive impulse output; 5-pin: +12V;
16	HEAT	Compressor electrical heater	Compressor electric heating belt
17	VA-1	Chassis electrical heater	Chassis electric heating belt
18	4V	4-way valve	4-way valve

◆ GUHD18NK3FO/GUHD24NK3FO/ GUHD30NK3FO/ GUHD36NK3FO/ GUHD42NK3FO

(1) Driving Board

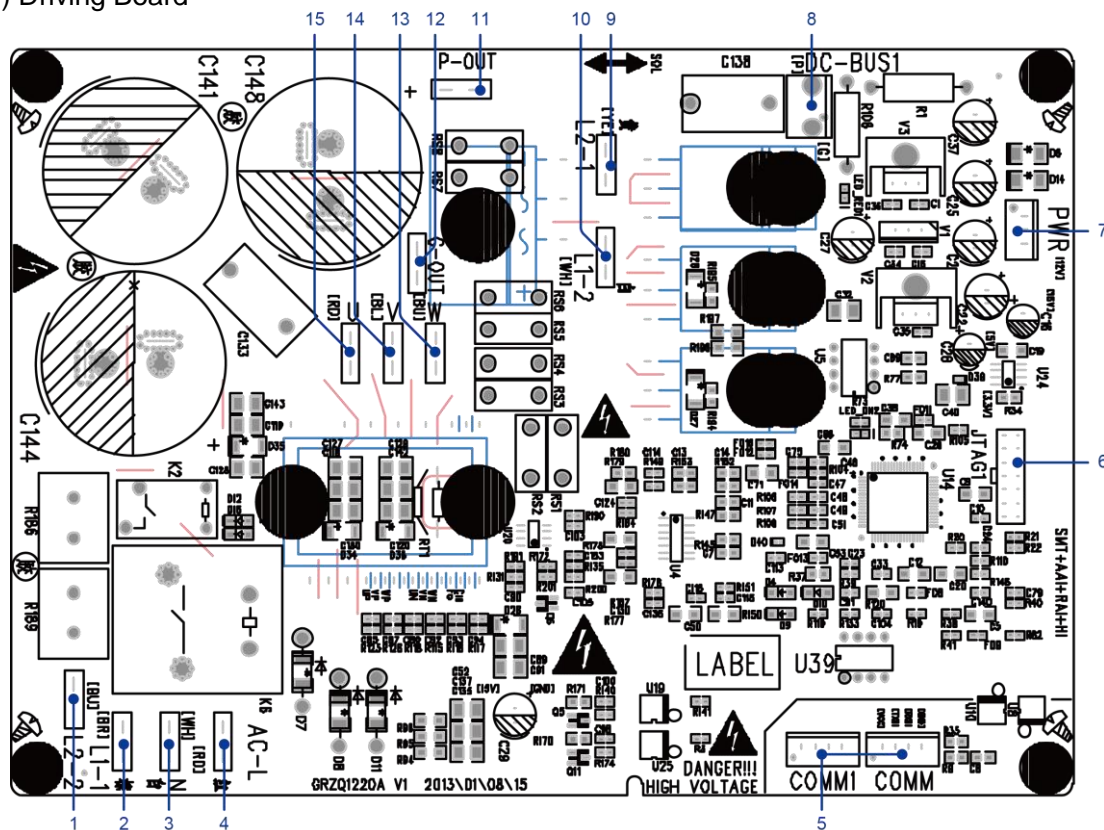

No.	Printing	Interface	No.	Printing	Interface
1	L2_2	PFC induction wire (blue)	2	L1_1	PFC induction wire (brown)
3	N	Neutral wire input (white)	4	AC-L	Live wire input (red)
5	COMM/COMM1	Communication interface	6	JTAG1	(Reserved)
7	PWR	Control power input	8	DC-BUS1	Bus electric discharging interface (for testing)
9	L2-1	PFC induction wire (yellow)	10	L1-2	PFC induction wire (white)
11	P-OUT	(Reserved)	12	G-OUT	(Reserved)
13	W	Compressor Phase W	14	V	Compressor Phase V
15	U	Compressor Phase U			

(2) Filtering Board:

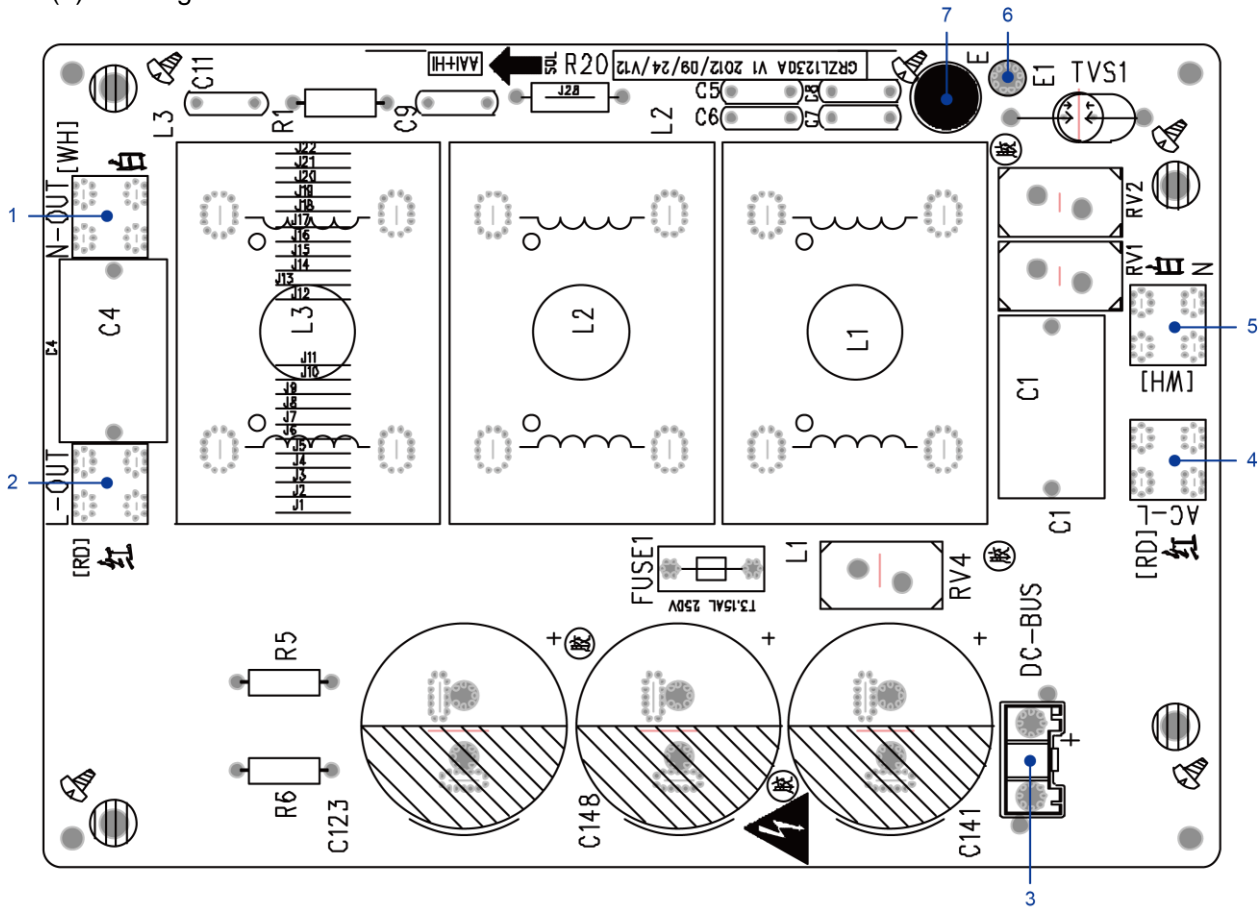

No.	Printing	Interface	No.	Printing	Interface
1	N-OUT	Neutral wire output (white)	2	L-OUT	Live wire output (red)
3	DC-BUS	DC bus interface (connect to drive board)	4	AC-L	Live wire input (red)
5	N	Neutral wire input (white)	6	E1	(Reserved)
7	E	Grounding wire (screw hole)			

◆ GUHD36NM3FO/GUHD42NM3FO/GUHD48NM3FO/GUHD60NM3FO

(1) Drive Board:

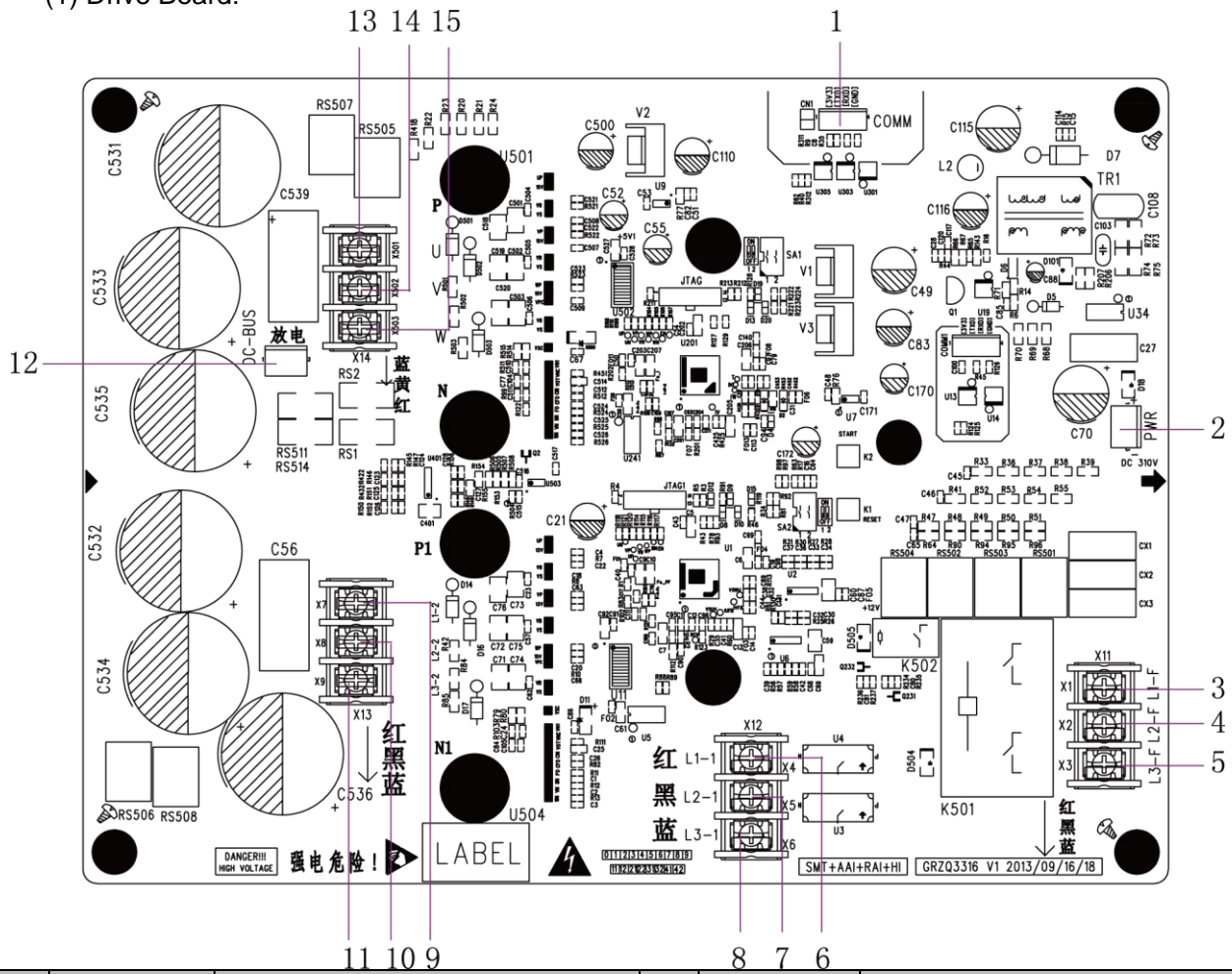

No.	Terminal name	Corresponding function instruction	No.	Terminal name	Corresponding function instruction
1	COMM	Communication interface [1-3.3V, 2-TX, 3-RX, 4-GND] (connect to main control board COMM1)	9	X7	Connect to PFC reactor 1 outlet line L1-2
2	PWR	Power interface [1-310VDC, 3-GND] (connect to main control board PWR1)	10	X8	Connect to PFC reactor 2 outlet line L2-2
3	X1	Three phase input L1-F (connect to filter board L1-F)	11	X9	Connect to PFC reactor 3 outlet line L3-2
4	X2	Three phase input L2-F (connect to filter board L2-F)	12	DC-BUS	Busbar high voltage discharge needle stand, for testing, not connect to line
5	X3	Three phase input L3-F (connect to filter board L3-F)	13	X501	Connect to compressor U phase
6	X4	Connect to PFC reactor 1 inlet line L1-1	14	X502	Connect to compressor V phase
7	X5	Connect to PFC reactor 2 inlet line L2-1	15	X503	Connect to compressor W phase
8	X6	Connect to PFC reactor 3 inlet line L3-1			

(2) Filtering Board:

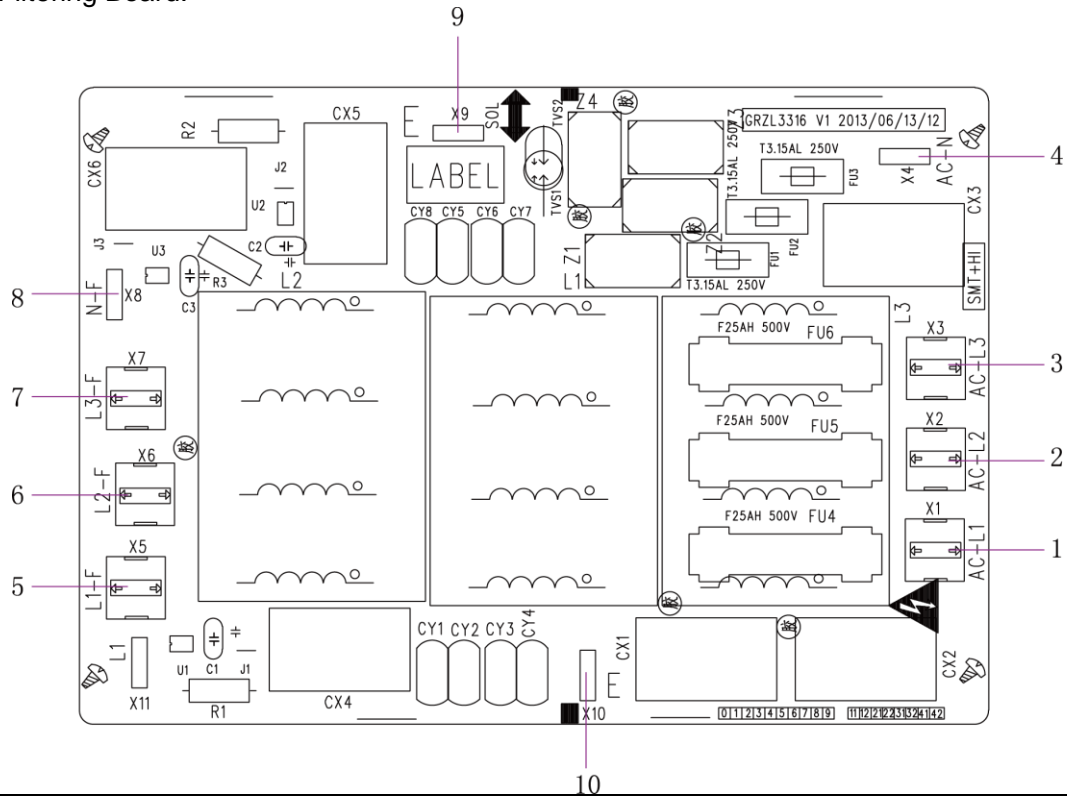

No.	Terminal name	Interface instruction	No.	Terminal name	Interface instruction
1	X1	Complete unit power input wire AC-L1	6	X6	Power output wire L2-F (connect to drive board L2-F)
2	X2	Complete unit power input wire AC-L2	7	X7	Power output wire L3-F (connect to drive board L3-F)
3	X3	Complete unit power input wire AC-L3	8	X8	Power output neutral wire N-F (connect to drive board AC-N)
4	X4	Complete unit power input neutral wire AC-N	9	X9	Grounding wire E, reserved
5	X5	Power output wire L1-F (connect to drive board L1-F and main control board AC-L)	10	X10	Grounding wire E

2.4 IPM, PFC Testing Method

2.4.1 Method of Testing IPM Module

(1) Preparation before test: Prepare a universal meter and turn to its diode option, and then remove the wires U, V, W of the compressor after it is powered off for one minute.

(2) Testing Steps

Step 1: put the black probe on the place P and the red one on the wiring terminal U, V, W respectively as shown in the following figure to measure the voltage between UP, VP and WP.

Step 2: put the red probe on the place N and the black one on the wiring terminal U, V, W respectively as shown in the following figure to measure the voltage between NU, NV and NW.

(3) If the measured voltages between UP, VP, WP, NU, NV, NV are all among 0.3V-0.7V, then it indicates the IPM module is normal; If any measured valve is 0, it indicates the IPM is damaged.

2.4.2 Method of Testing PFC Module Short Circuit: (only for GUHD48NK3FO)

(1) Preparation before test: Prepare a universal meter and turn to its diode option, and then remove the wires L1-2, L2-1 after it is powered off for one minute.

(2) Testing Steps

Step 1: put the black probe on the place P and the red one on the wiring terminal L1-2, L2-1 respectively as shown in the following figure to measure the voltage between L1-2P and L2-1 P.

Step 2: put the red probe on the place N and the black one on the wiring terminal L1-2, L2-1 respectively as shown in the following figure to measure the voltage between N L1-2 and NL2-1.

(3) If the measured voltages between L1-2P, L2-1 P, N L1-2, NL2-1 are all among 0.3V-0.7V, then it indicates the PFC module is normal; If any measured value is 0, it indicates the PFC is damaged.

◆ GUHD09NK3FO/GUHD12NK3FO

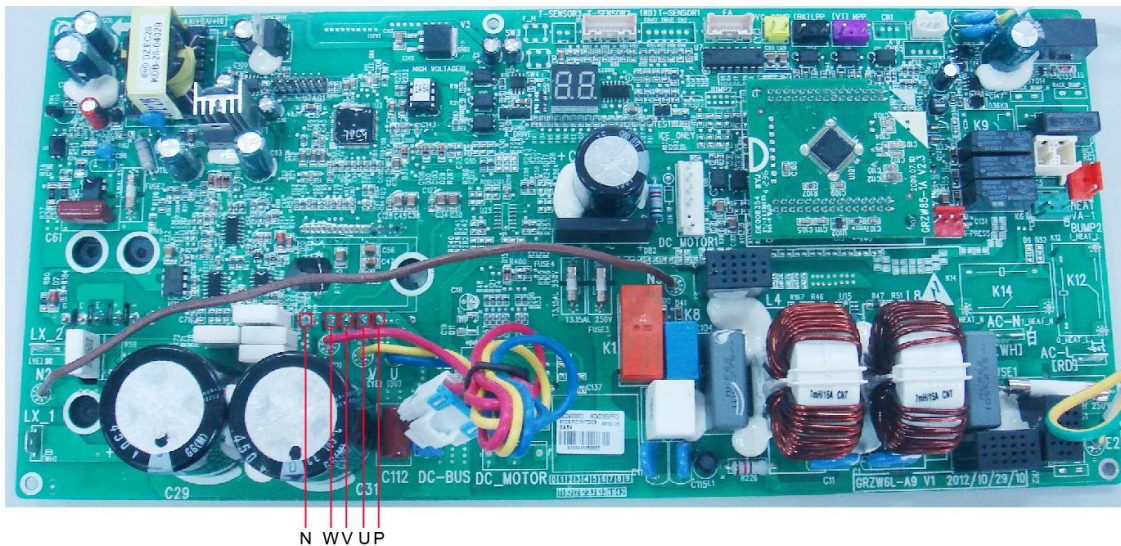

◆ GUHD18NK3FO/GUHD24NK3FO/GUHD30NK3FO/GUHD36NK3FO/GUHD42NK3FO/GUHD36NM3FO/ GUHD42NM3FO

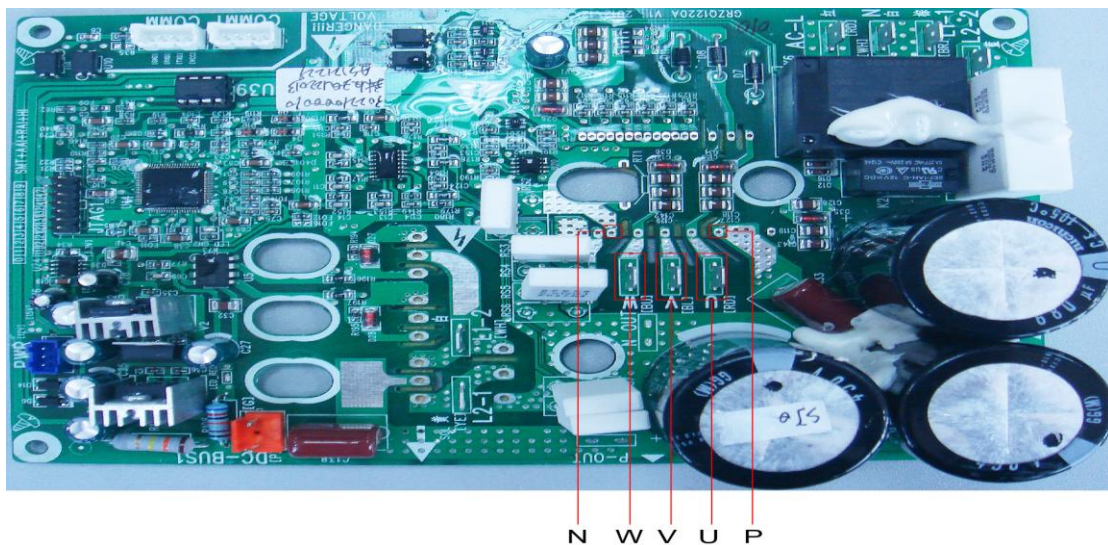

◆ GUHD48NK3FO/GUHD48NM3FO/GUHD60NM3FO

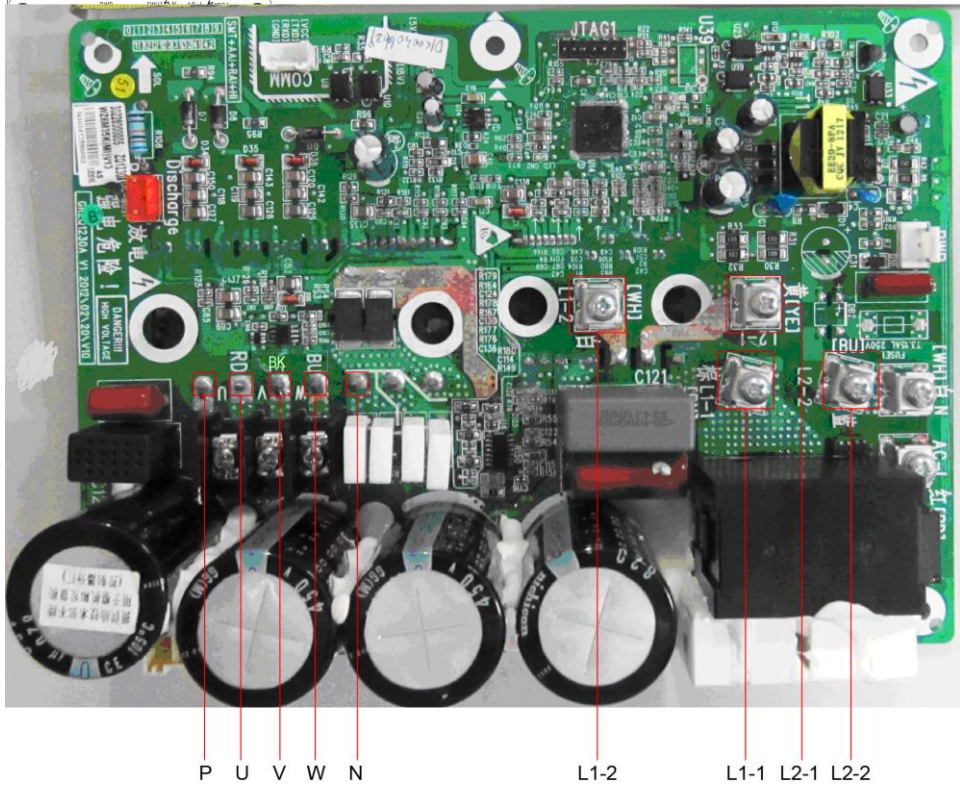

P U V W N

L1-2

L1-1 L2-1 L2-2

3 WIRING DIADRAM

3.1 Outdoor unit

The actual wiring should always refer to the wiring diagram of the unit.

Model: GUHD09NK3FO, GUHD12NK3FO

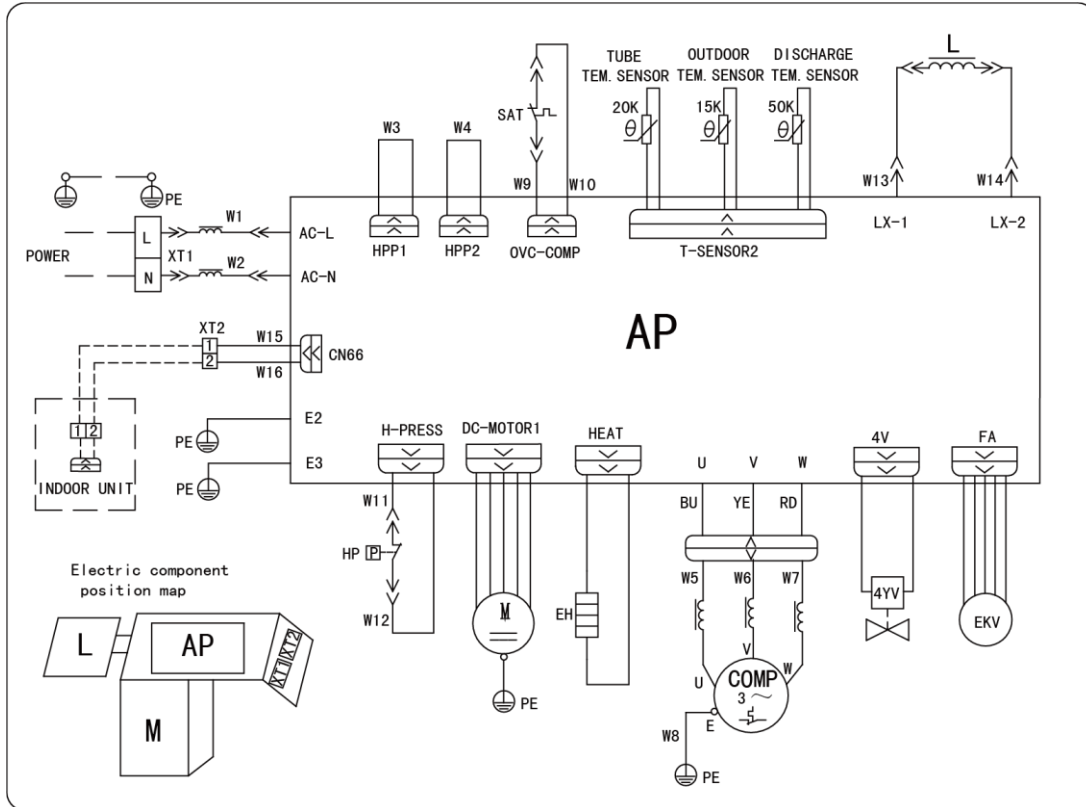

Model: GUHD18NK3FO

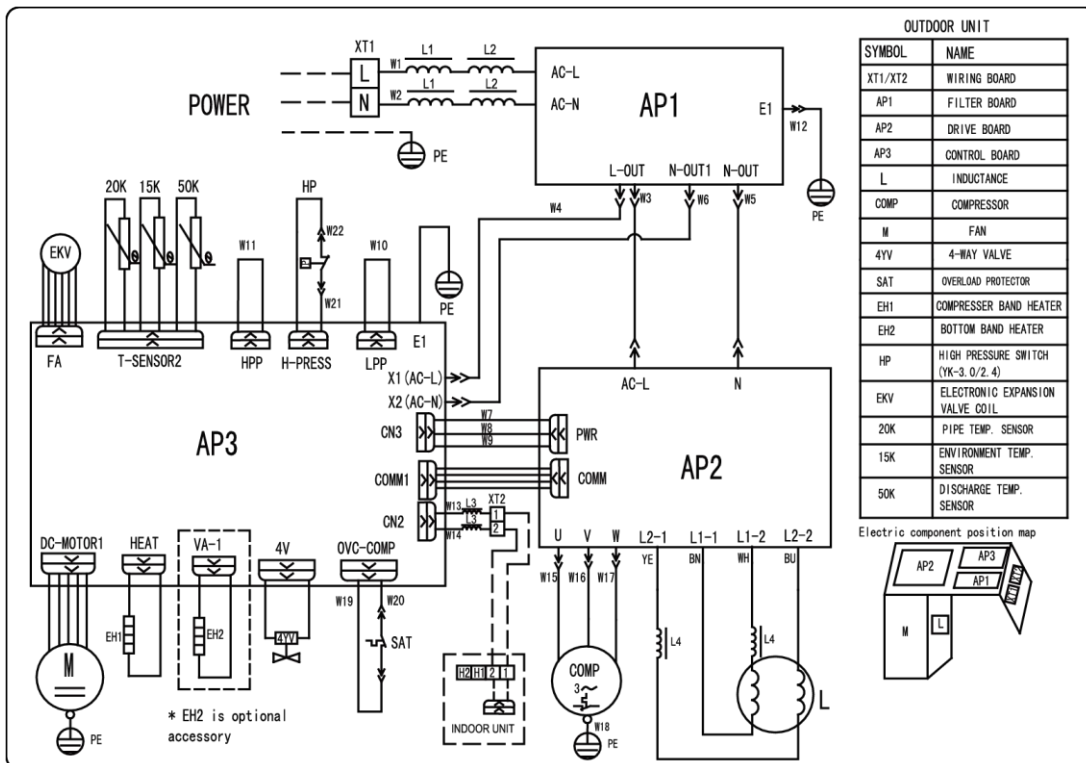

Model: GUHD24NK3FO, GUHD30NK3FO

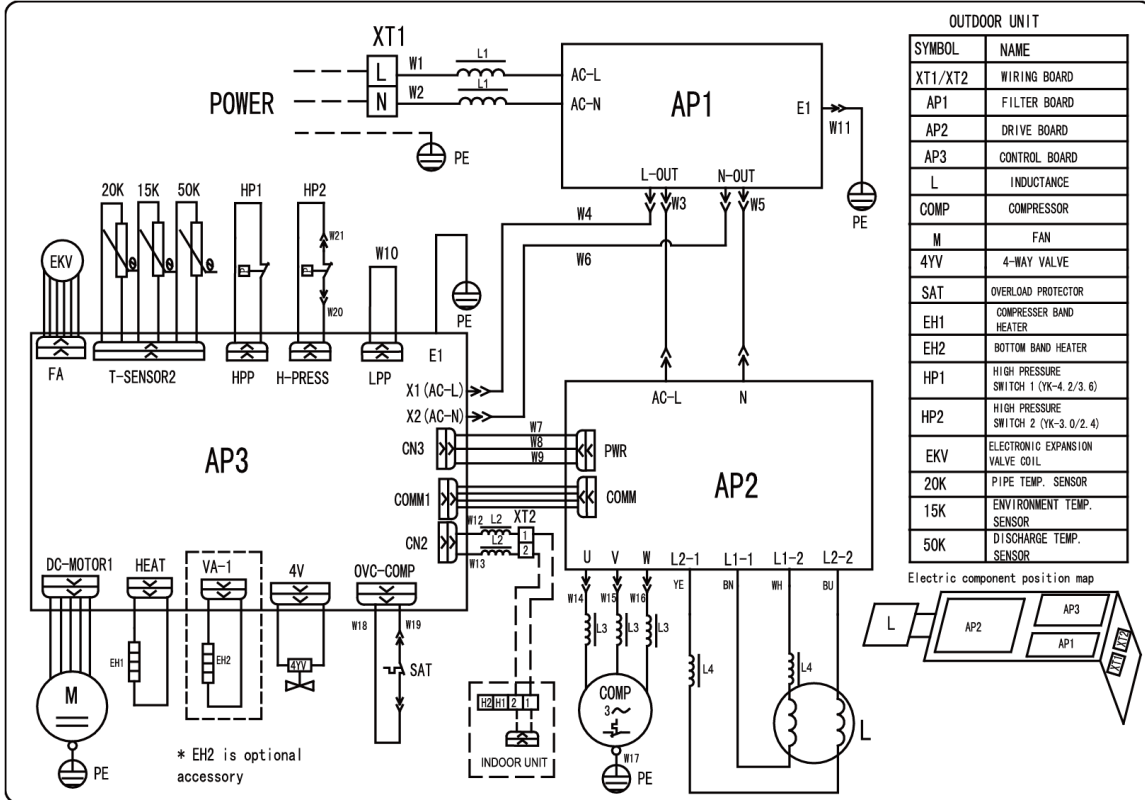

Model: GUHD36NK3FO

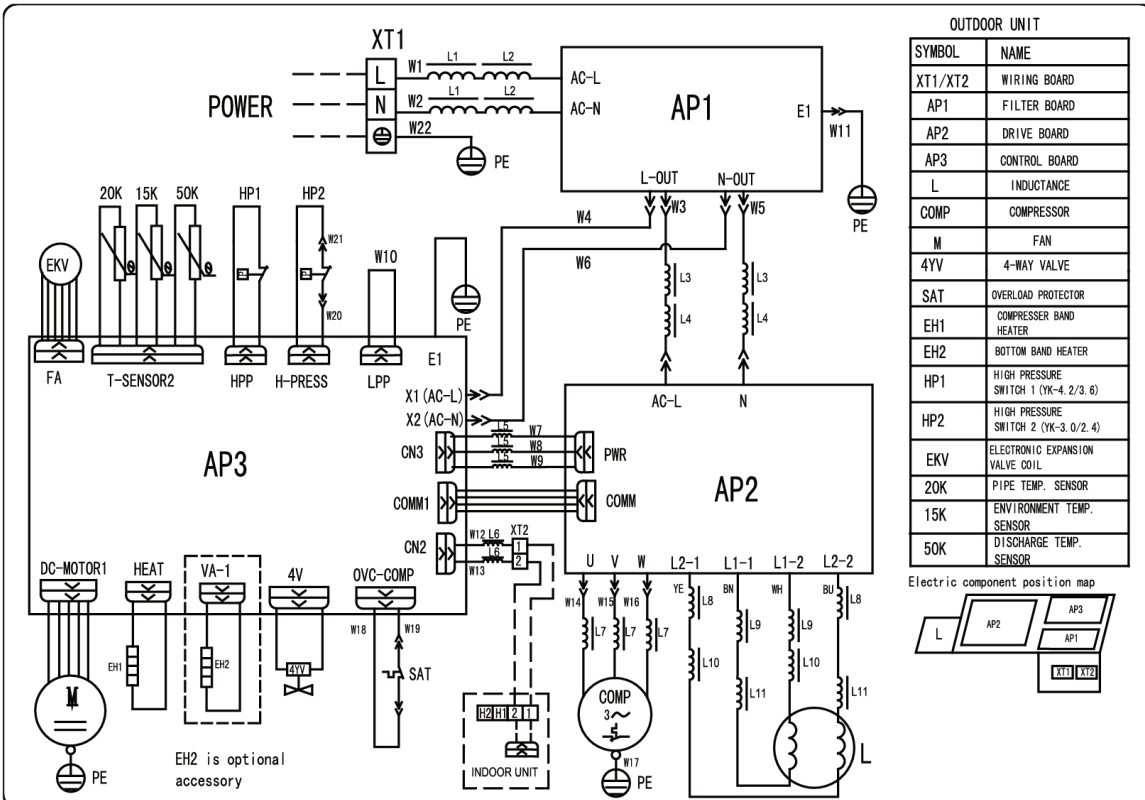

Model: GUHD42NK3FO

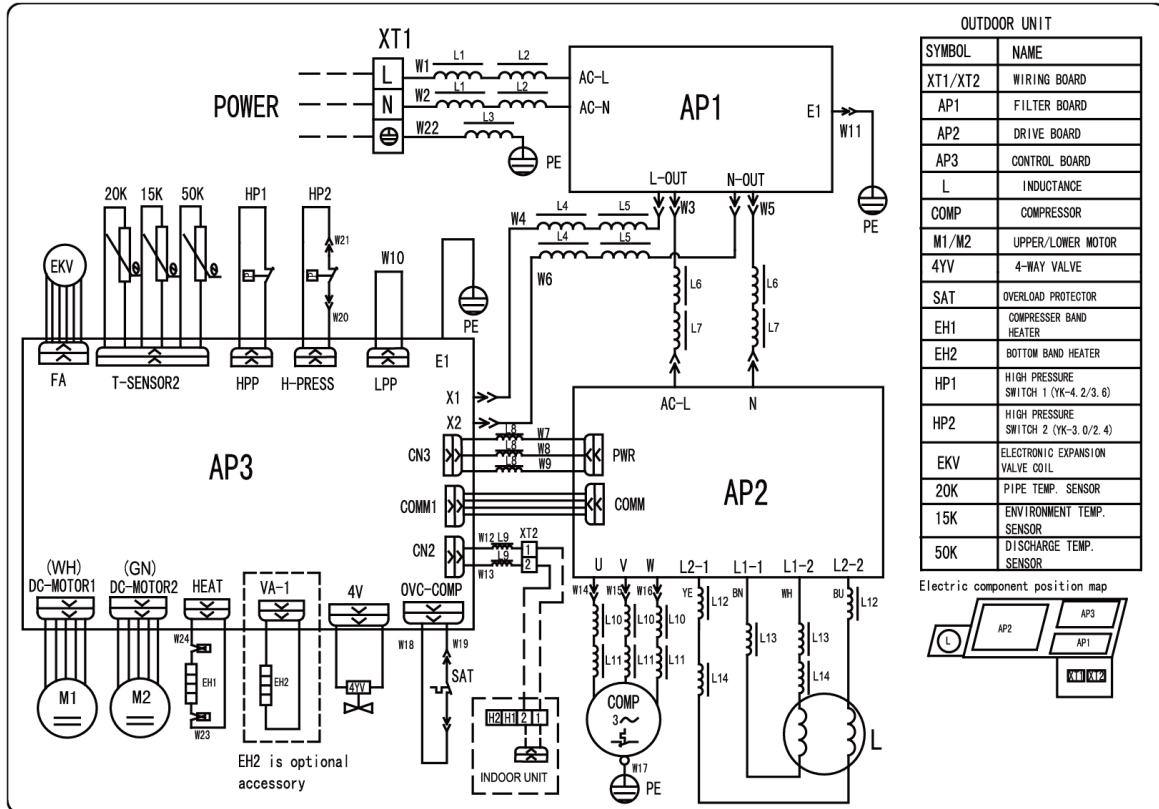

Model: GUHD48NK3FO

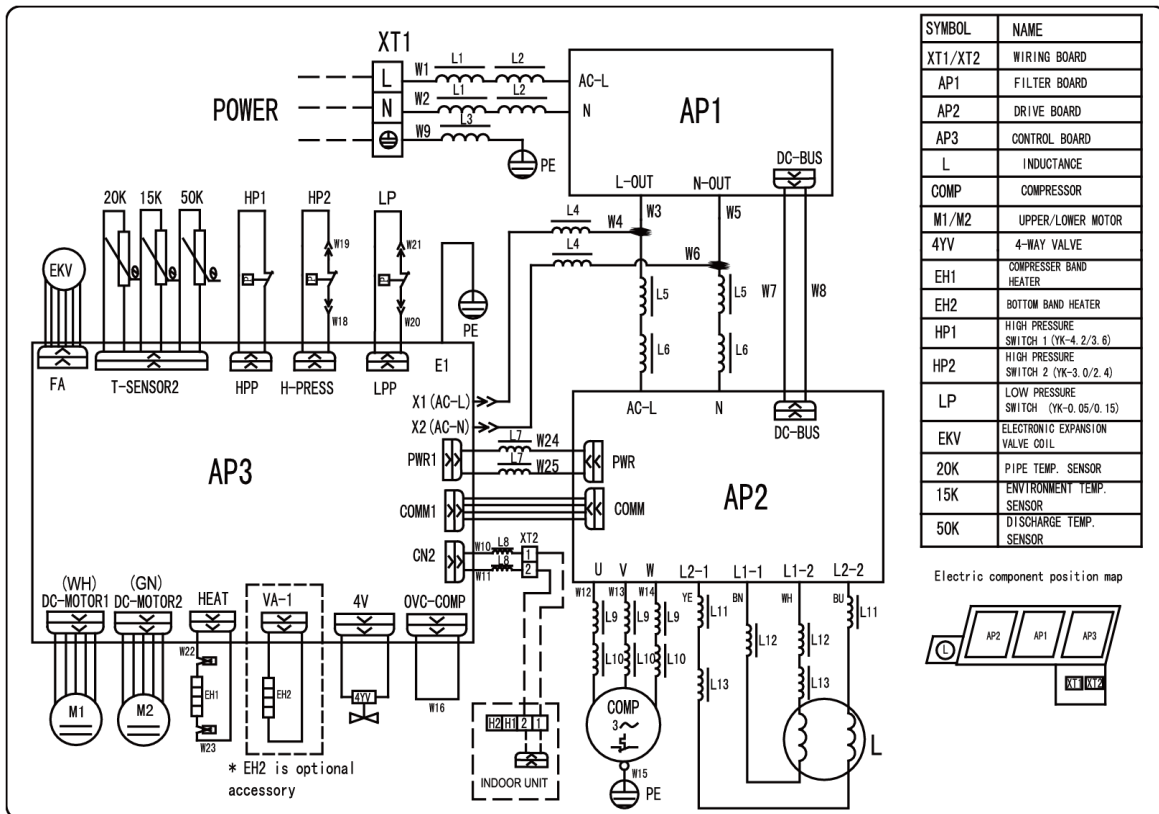

Model: GUHD36NM3FO

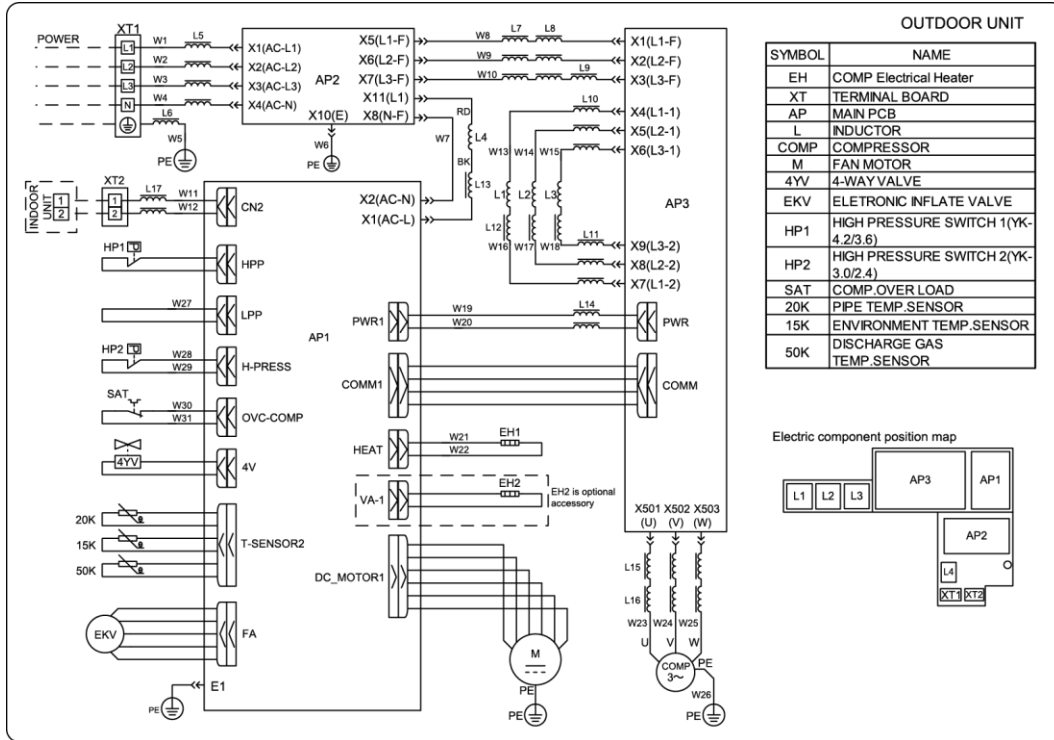

Model: GUHD42NM3FO

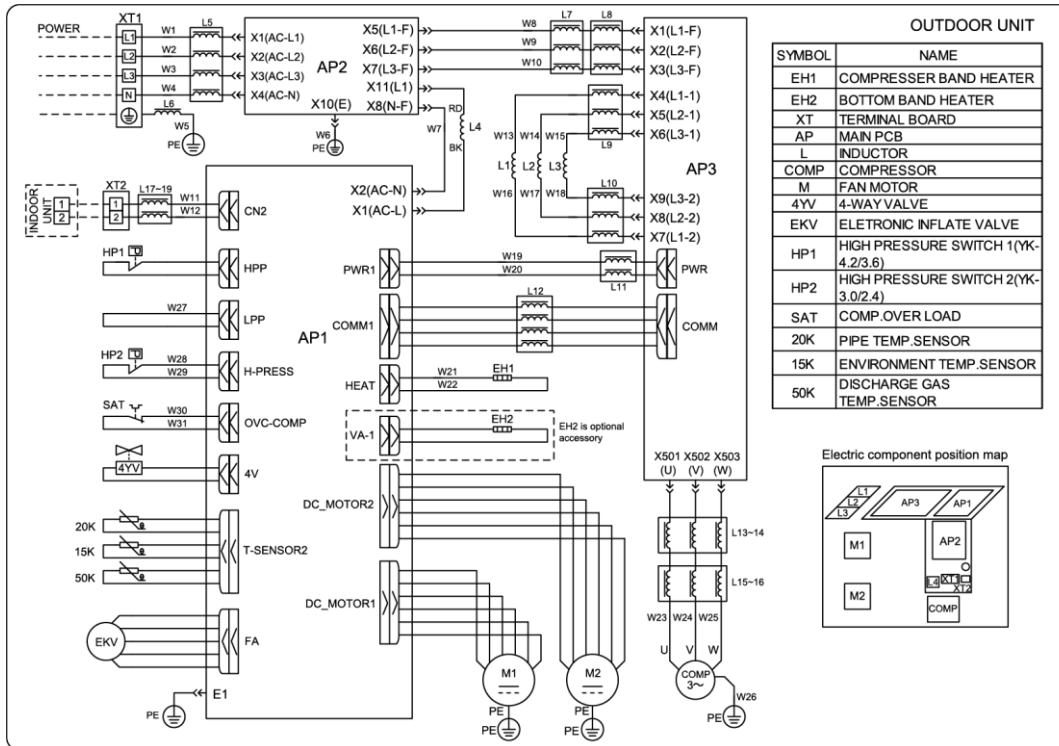

Model: GUHD48NM3FO

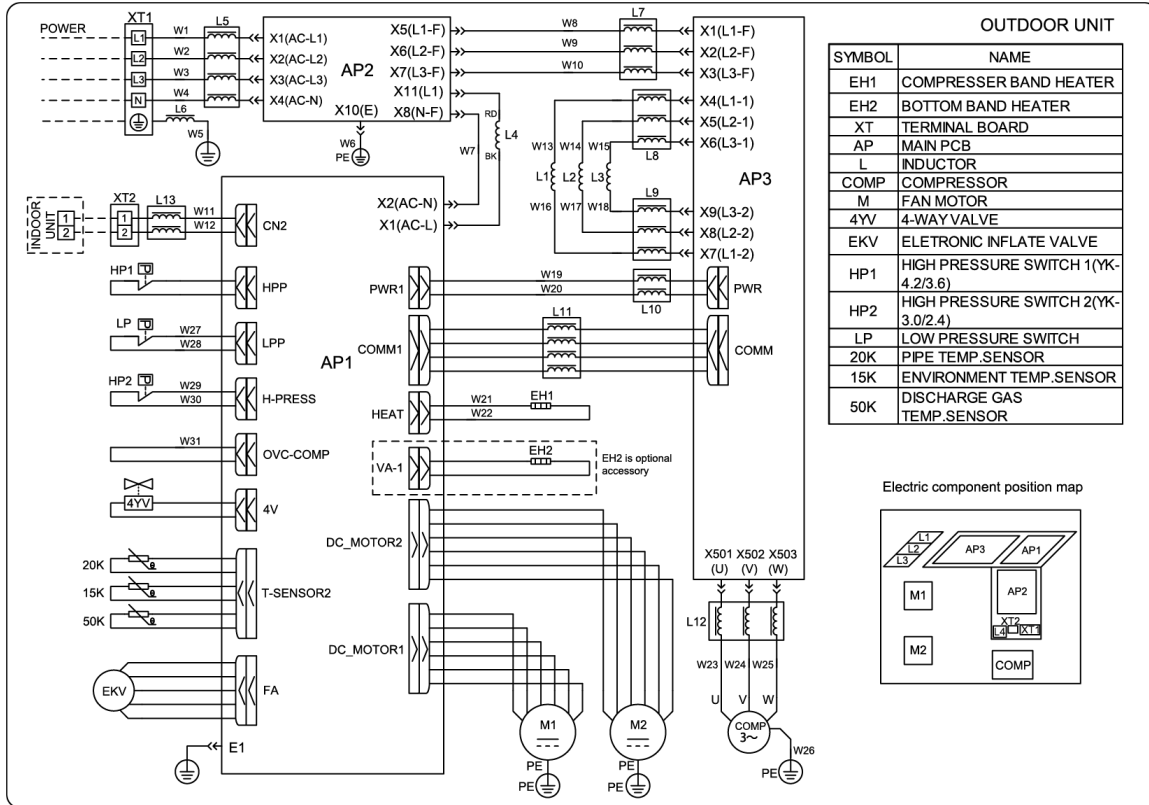

OUTDOOR UNIT	
SYMBOL	NAME
EH1	COMPRESSOR BAND HEATER
EH2	BOTTOM BAND HEATER
XT	TERMINAL BOARD
AP	MAIN PCB
L	INDUCTOR
COMP	COMPRESSOR
M	FAN MOTOR
4YV	4-WAY VALVE
EKV	ELETRONIC INFLATE VALVE
HP1	HIGH PRESSURE SWITCH 1(YK-4.2/3.6)
HP2	HIGH PRESSURE SWITCH 2(YK-3.0/2.4)
LP	LOW PRESSURE SWITCH
20K	PIPE TEMP.SENSOR
15K	ENVIRONMENT TEMP.SENSOR
50K	DISCHARGE GAS TEMP.SENSOR

Electric component position map

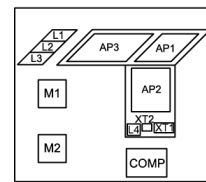

Model: GUHD60NM3FO

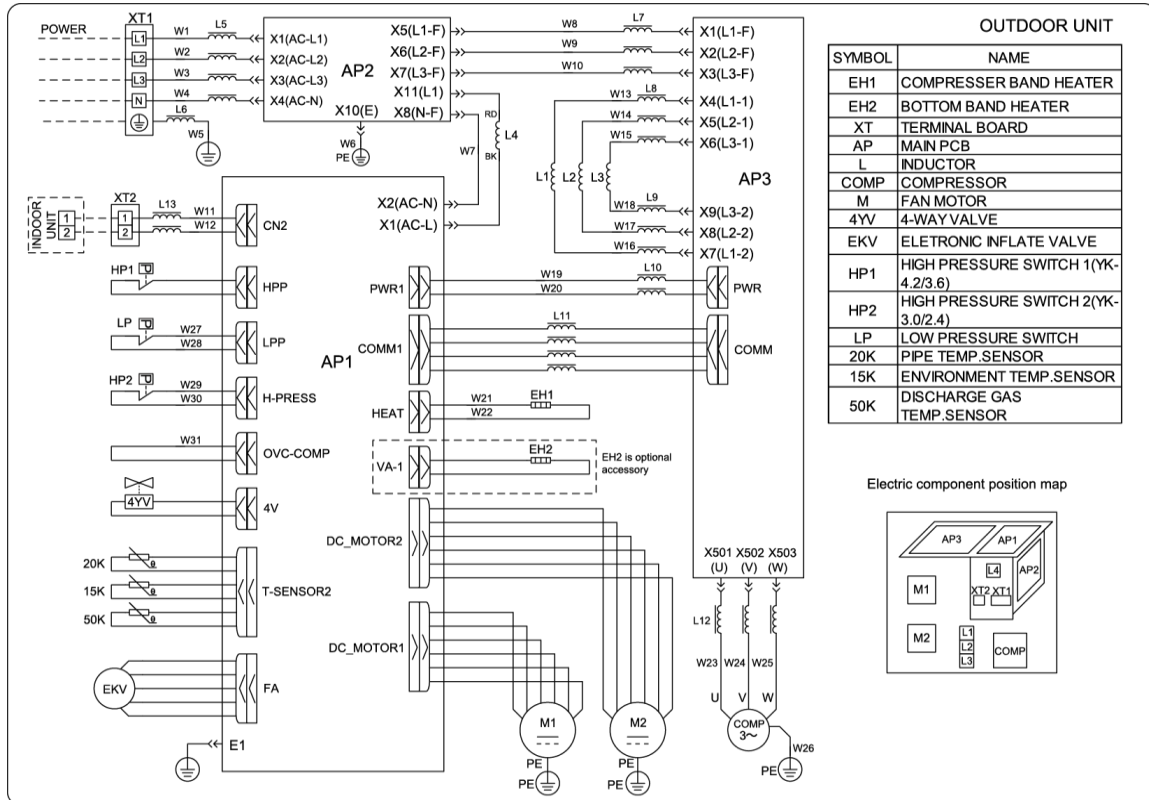

OUTDOOR UNIT	
SYMBOL	NAME
EH1	COMPRESSOR BAND HEATER
EH2	BOTTOM BAND HEATER
XT	TERMINAL BOARD
AP	MAIN PCB
L	INDUCTOR
COMP	COMPRESSOR
M	FAN MOTOR
4YV	4-WAY VALVE
EKV	ELETRONIC INFLATE VALVE
HP1	HIGH PRESSURE SWITCH 1(YK-4.2/3.6)
HP2	HIGH PRESSURE SWITCH 2(YK-3.0/2.4)
LP	LOW PRESSURE SWITCH
20K	PIPE TEMP.SENSOR
15K	ENVIRONMENT TEMP.SENSOR
50K	DISCHARGE GAS TEMP.SENSOR

Electric component position map

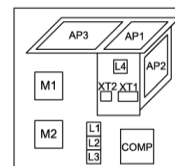

3.2 Indoor unit

The actual wiring should always refer to the wiring diagram of the unit.

3.2.1 Duct Type

- ◆ Model: GFH09K3FI, GFH12K3FI, GFH18K3FI, GFH24K3FI, GFH30K3FI, GFH36K3FI, GFH42K3FI

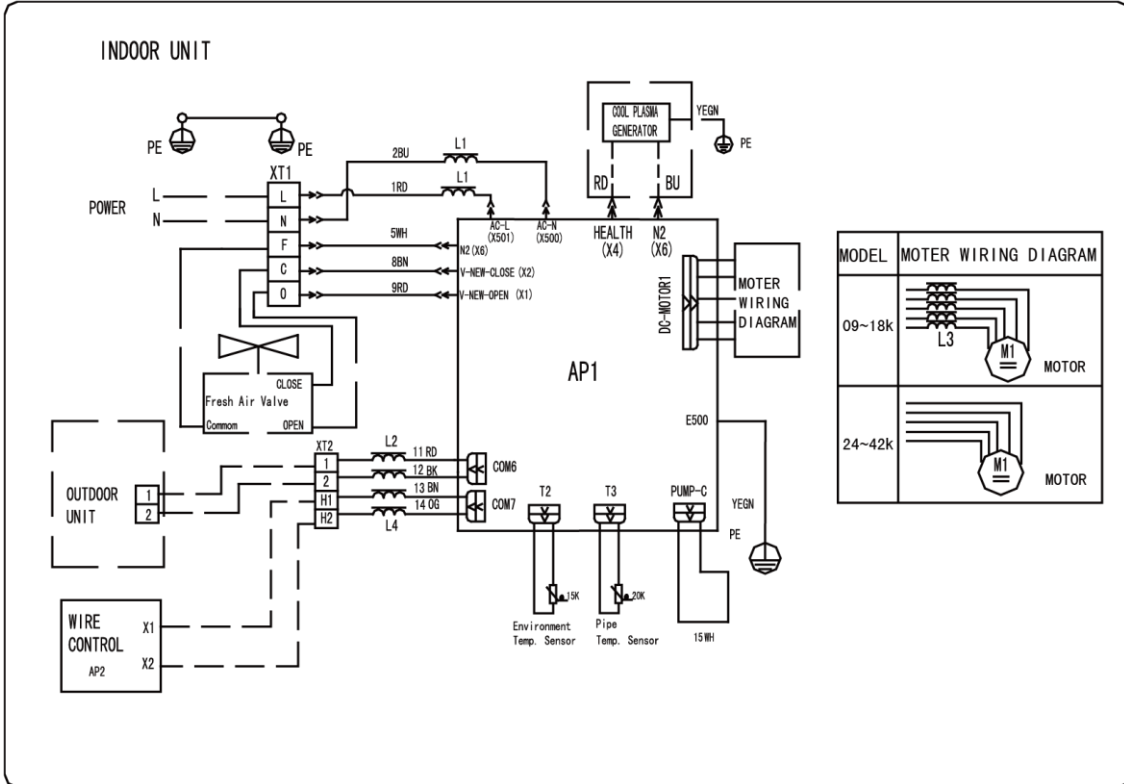

- ◆ Model: GFH48K3FI, GFH60K3FI

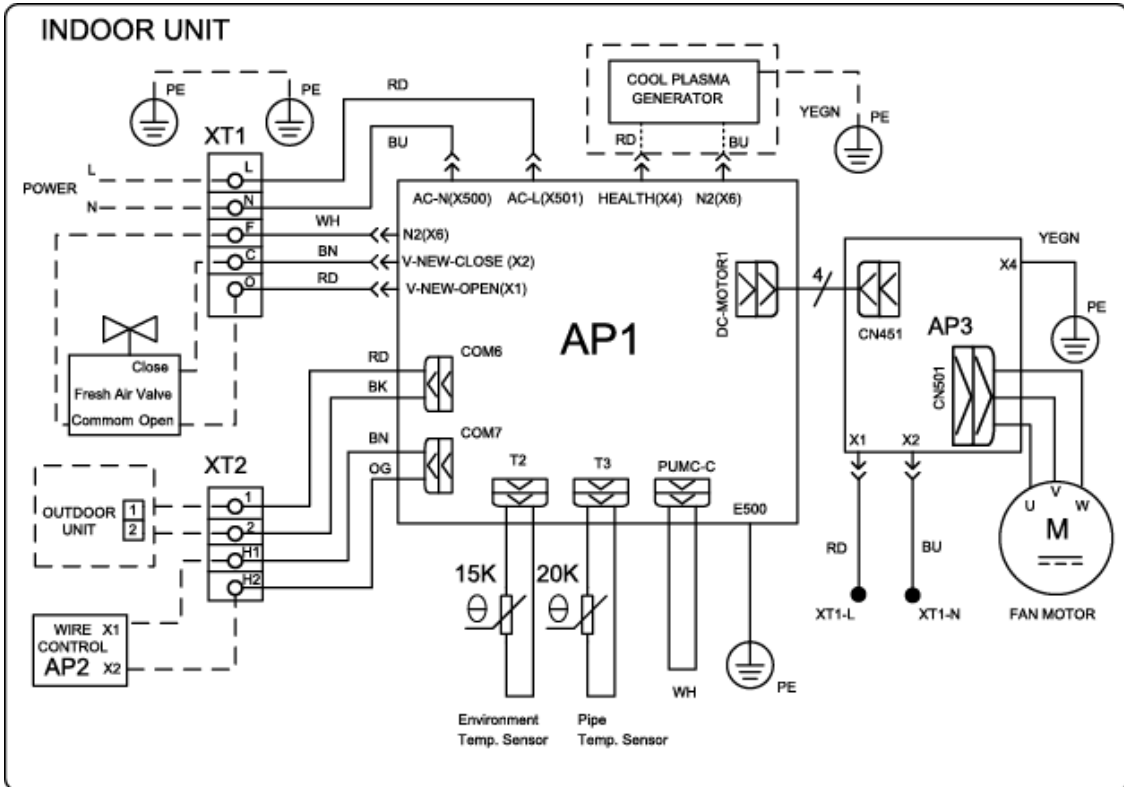

3.2.2 Floor Ceiling Type

- ◆ Model: GTH09K3FI, GTH12K3FI, GTH18K3FI, GTH24K3FI, GTH30K3FI, GTH36K3FI, GTH42K3FI, GTH48K3FI, GTH60K3FI

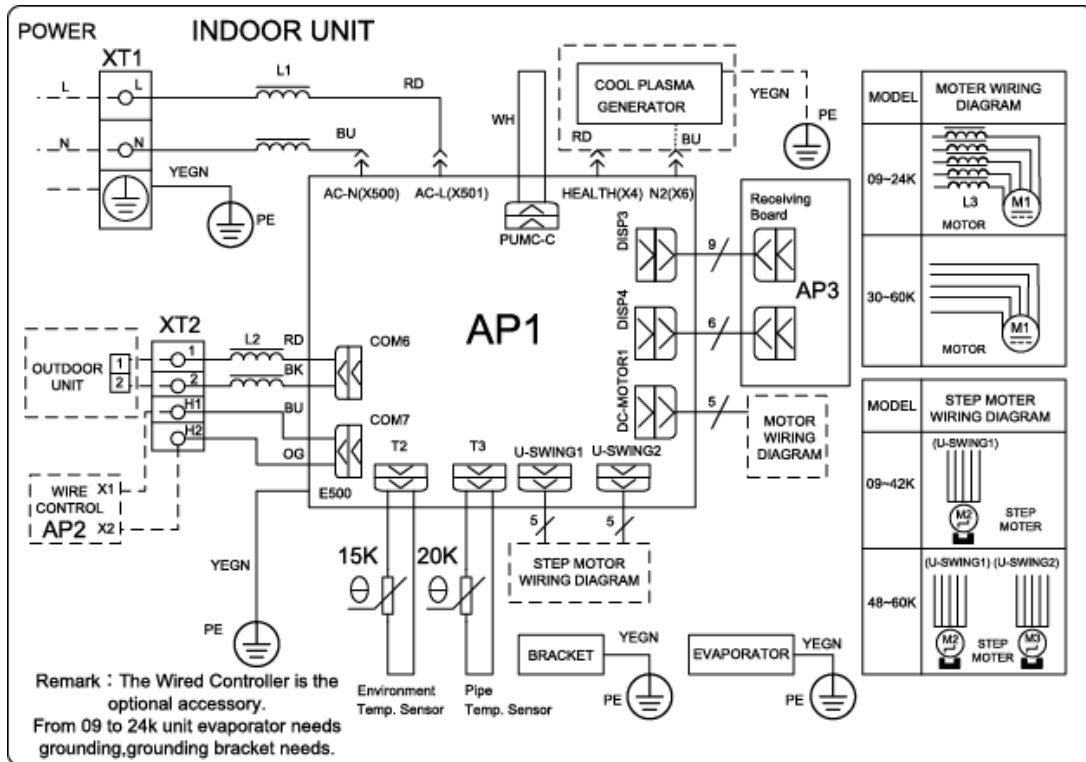

3.2.3 Cassette Type

- ◆ Model: GKH12K3FI, GKH18K3FI

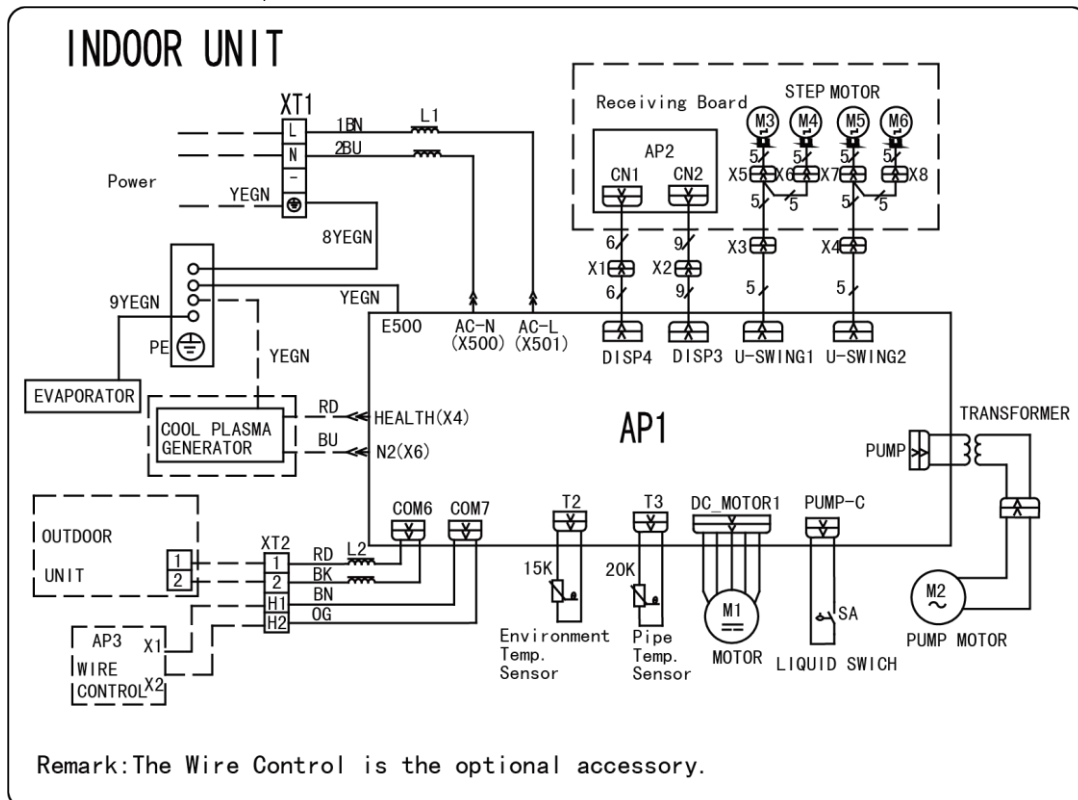

◆ Model: GKH24K3FI, GKH30K3FI

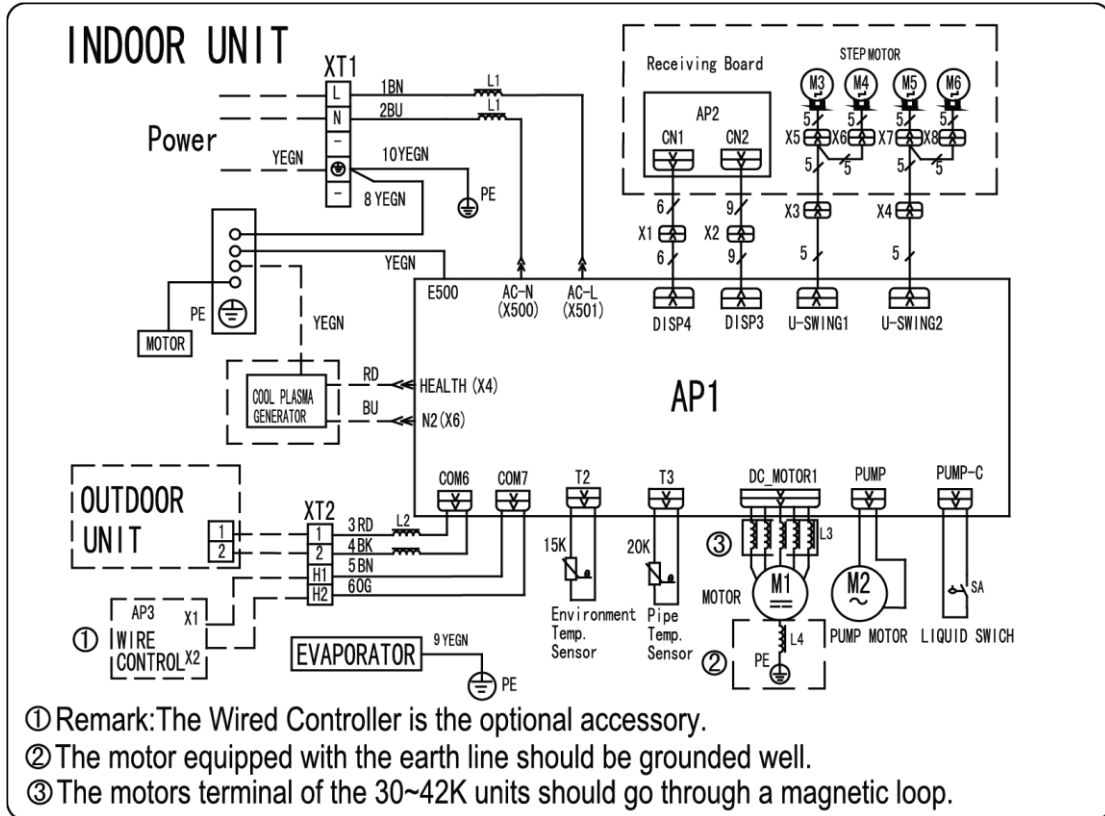

◆ Model: GKH36K3FI, GKH42K3FI

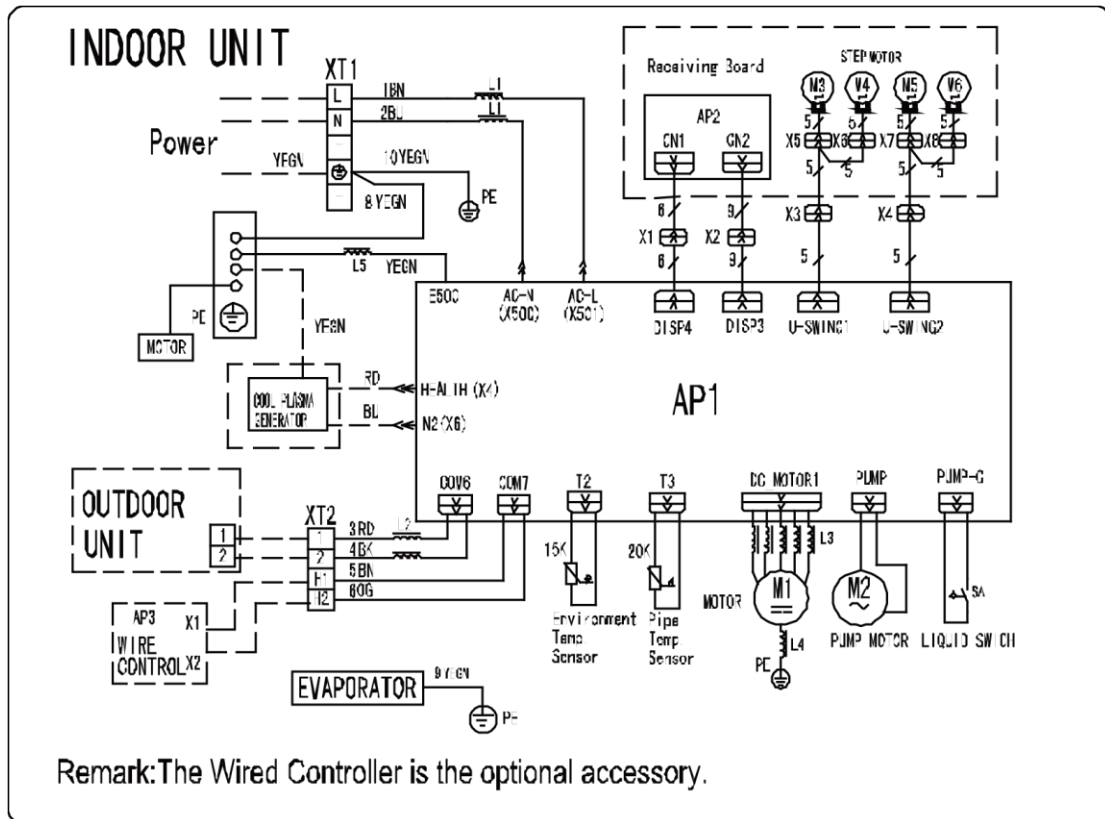

◆ Model: GKH48K3FI, GKH60K3FI

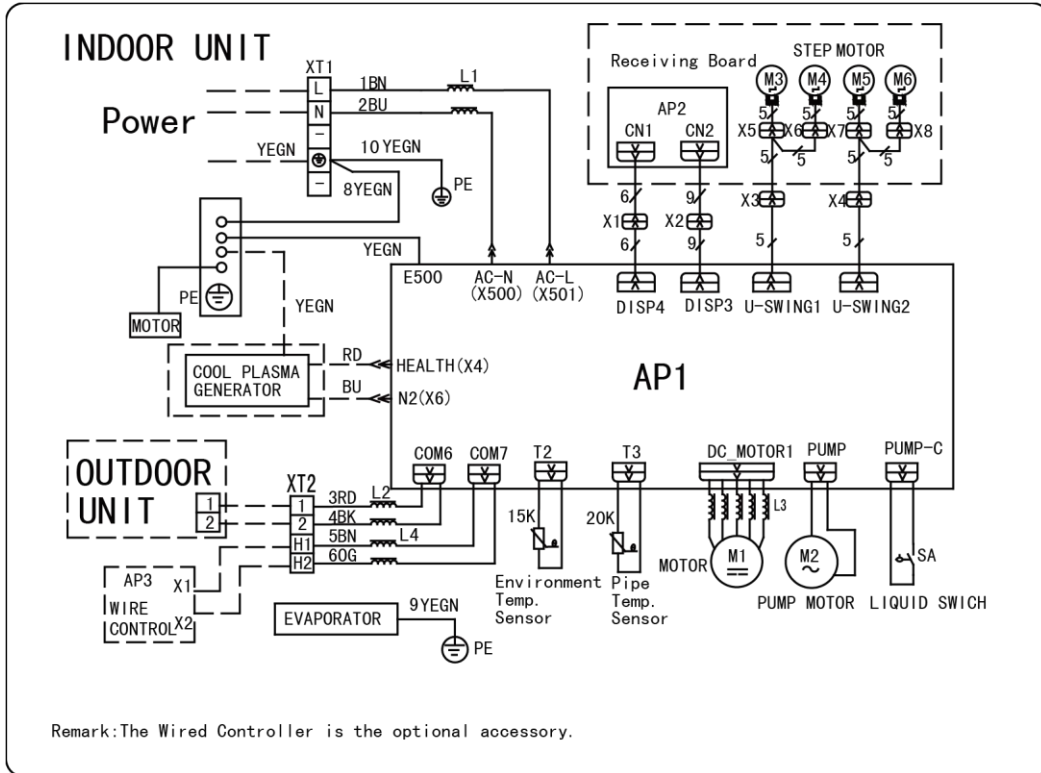

4. DISASSEMBLY AND ASSEMBLY PROCEDURE OF MAIN PARTS

4.1 Outdoor Unit

◆ 09/12k

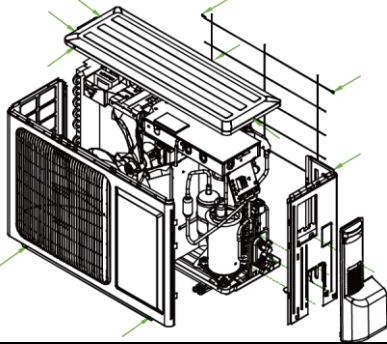
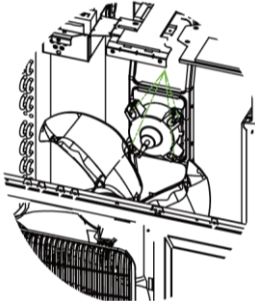
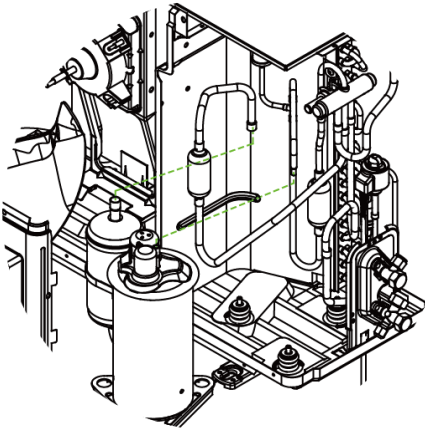
Disassembly and Assembly of external casing		
Remark :		
Step	Illustration	Handling Instruction
1. Remove external casing		<ol style="list-style-type: none"> 1. Remove the top cover and handle; 2. Remove the grille, outer case and right side plate.
2. Remove motor		<ol style="list-style-type: none"> 1. Remove the blade nut and then remove the blade; 2. Remove the motor from motor support.
3. Remove compressor		<ol style="list-style-type: none"> 1. Discharge the refrigerant inside the pipeline and recycle the refrigerant during discharging; 2. Unsolder the 4-way valve assy from compressor; 3. Remove the nut fixing compressor; 4. Take away the compressor from chassis.

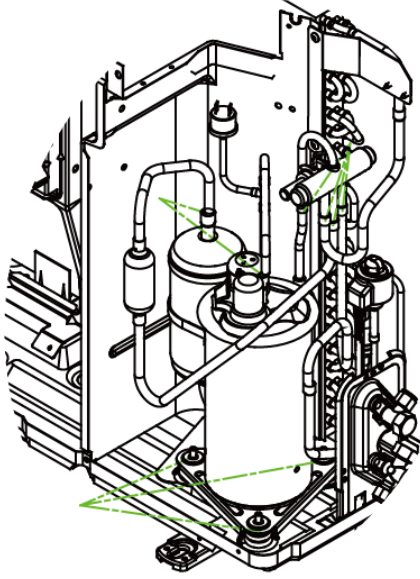
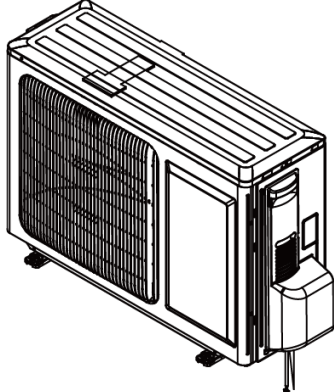
<p>4. Assemble compressor</p>		<ol style="list-style-type: none"> 1. Fix the new compressor on to the chassis; 2. Connect the suction port and discharge port of compressor with the system pipes; 3. Properly connect the power cord of compressor; 4. Renew the compressor electric heating belt and discharge temperature sensor; 5. Check if the compressor rotates in reverse and if the lubricant have leaked.
<p>5. Assemble unit</p>		<p>Assemble the unit in the reverse procedures of disassembly.</p>

◆ 18k

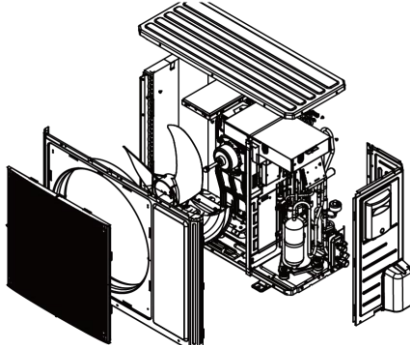
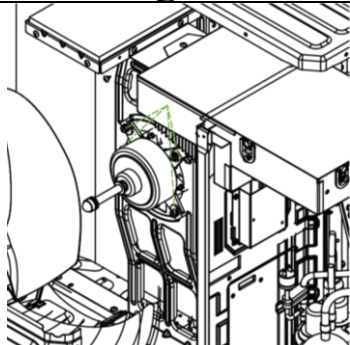
Disassembly and Assembly of external casing		
Remark :		
Step	Illustration	Handling Instruction
<p>1. Remove external casing</p>		<ol style="list-style-type: none"> 1. Remove the top cover and handle; 2. Remove the grille, outer case and right side plate.
<p>2. Remove motor</p>		<ol style="list-style-type: none"> 1. Remove the blade nut and then remove the blade; 2. Remove the motor from motor support.

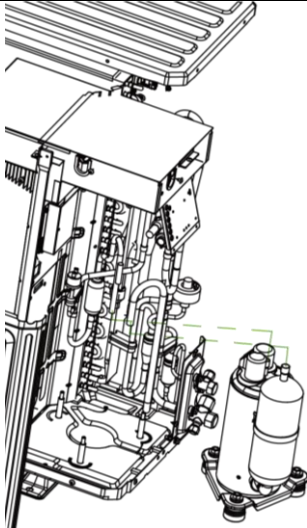
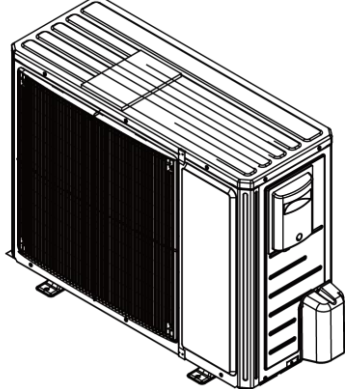
<p>3. Remove compressor</p>		<ol style="list-style-type: none"> 1. Discharge the refrigerant inside the pipeline and recycle the refrigerant during discharging; 2. Unsolder the 4-way valve assy from compressor; 3. Remove the nut fixing compressor; 4. Take away the compressor from chassis.
<p>4. Assemble unit</p>		<p>Assemble the unit in the reverse procedures of disassembly.</p>

◆ 24/30k

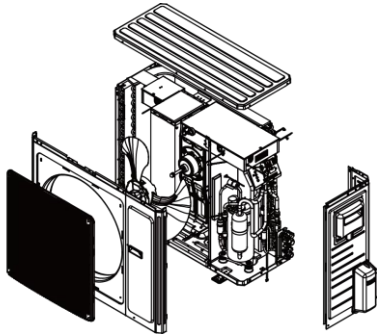
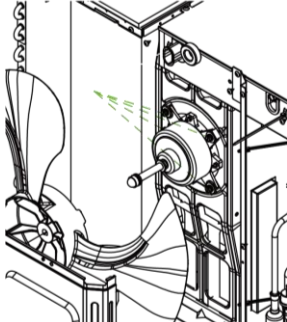
Disassembly and Assembly of external casing		
Remark :		
Step	Illustration	Handling Instruction
<p>1. Remove external casing</p>		<ol style="list-style-type: none"> 1. Remove the top cover and handle; 2. Remove the grille, outer case, front side plate and right side plate.
<p>2. Remove motor</p>		<ol style="list-style-type: none"> 1. Remove the blade nut and then remove the blade; 2. Remove the motor from motor support.

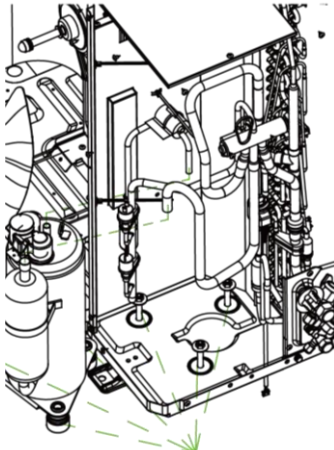
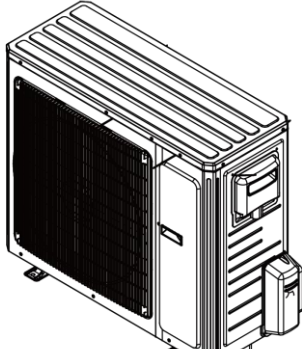
<p>3. Remove compressor</p>		<ol style="list-style-type: none"> 1. Discharge the refrigerant inside the pipeline and recycle the refrigerant during discharging; 2. Unsolder the 4-way valve assy from compressor; 3. Remove the nut fixing compressor; 4. Take away the compressor from chassis.
<p>4. Assemble unit</p>		<p>Assemble the unit in the reverse procedures of disassembly.</p>

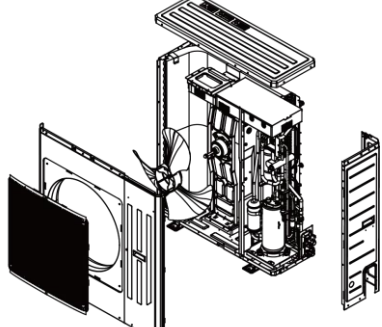
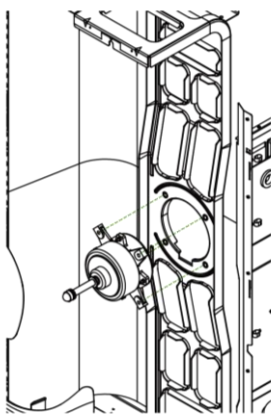

◆ 36k

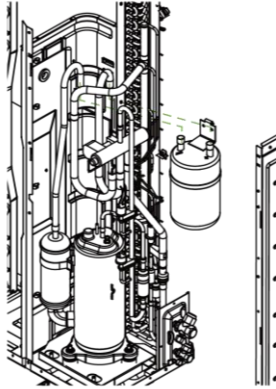
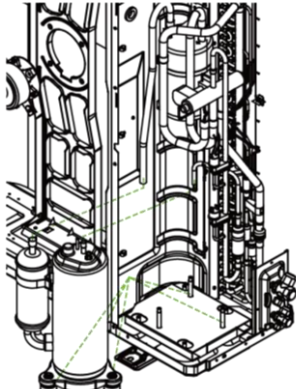
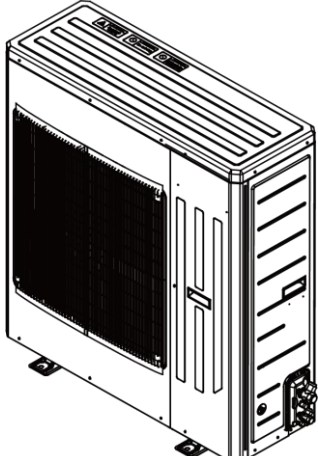
Disassembly and Assembly of external casing		
Remark :		
Step	Illustration	Handling Instruction
<p>1. Remove external casing</p>		<ol style="list-style-type: none"> 1. Remove the top cover and handle; 2. Remove the grille, outer case and right side plate.
<p>2. Remove motor</p>		<ol style="list-style-type: none"> 1. Remove the blade nut and then remove the blade; 2. Remove the motor from motor support.

<p>3. Remove gas liquid separator</p>		<ol style="list-style-type: none"> 1. Discharge the refrigerant inside the pipeline and recycle the refrigerant during discharging; 2. Unsolder the 4-way valve assy from gas liquid separator; 3. Remove the gas liquid separator.
<p>4. Remove compressor</p>		<ol style="list-style-type: none"> 1. Discharge the refrigerant inside the pipeline and recycle the refrigerant during discharging; 2. Unsolder the 4-way valve assy from compressor; 3. Remove the nut fixing compressor; 4. Take away the compressor from chassis.
<p>5. Assemble unit</p>		<p>Assemble the unit in the reverse procedures of disassembly.</p>

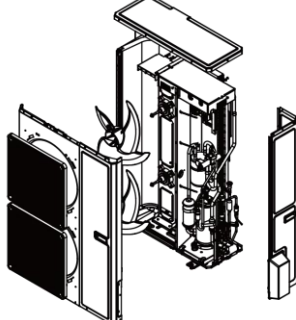
◆ 42k/48k/60k:

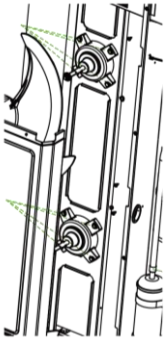
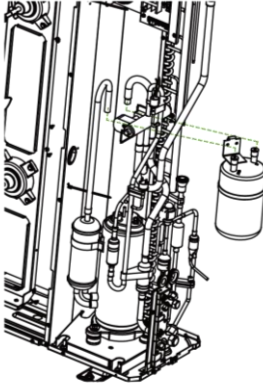
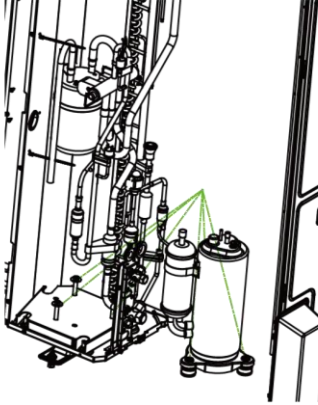
Disassembly and Assembly of external casing		
Remark :		
Step	Illustration	Handling Instruction
<p>1. Remove external casing</p>		<ol style="list-style-type: none"> 1. Remove the top cover and handle; 2. Remove the grille, outer case and right side plate.

<p>2. Remove motor</p>		<ol style="list-style-type: none"> 1. Remove the blade nut and then remove the blade; 2. Remove the motor from motor support.
<p>3. Remove gas liquid separator.</p>		<ol style="list-style-type: none"> 1. Discharge the refrigerant inside the pipeline and recycle the refrigerant during discharging; 2. Unsolder the 4-way valve assy from gas liquid separator; 3. Remove the gas liquid separator.
<p>4. Remove compressor</p>		<ol style="list-style-type: none"> 1. Discharge the refrigerant inside the pipeline and recycle the refrigerant during discharging; 2. Unsolder the 4-way valve assy from compressor; 3. Remove the nut fixing compressor; 4. Take away the compressor from chassis.
<p>5. Assemble unit</p>		<p>Assemble the unit in the reverse procedures of disassembly.</p>

4.2 Indoor Unit

4.2.1 Duct type

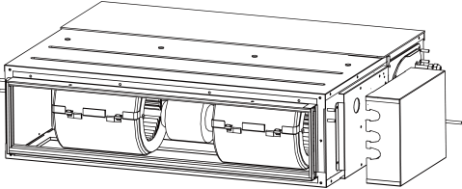
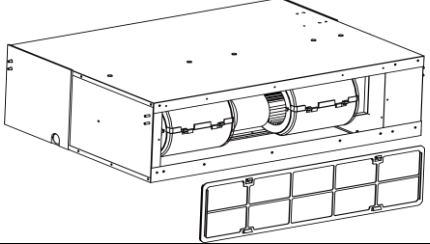
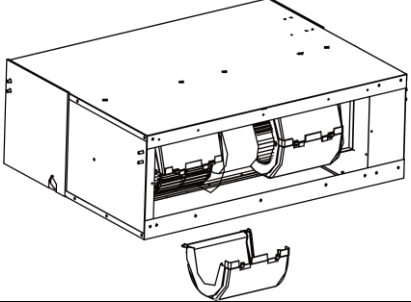
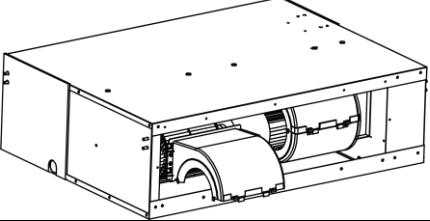
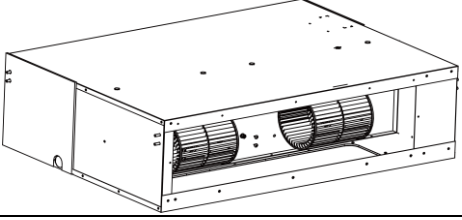
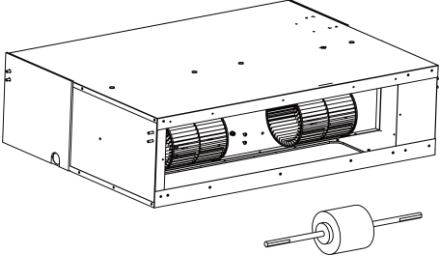
Removal and Assembly of Fan Motor		
Remarks: Before removing the fan, make sure to cut off the power firstly.		
Step	Illustration	Handling Instruction
1. Unplug the motor cables		Cut off the power supply of indoor unit. Use screwdriver to remove the electric box cover and unplug the motor cables in electric box.
2. Remove the filter sub-assembly and air inlet cover board		Remove the filter sub-assembly from the air inlet frame and use screwdriver to remove the air inlet cover board.
3. Remove the screws on fan sub-assembly.		Remove the screws on fan sub-assembly.
4. Overturn the propeller housing		Rotate the propeller housing to the air inlet according to arrow direction.
5. Loosen the fan and motor.		Use inner hexagonal spanner to loosen the screws on fan and remove the clamp fixing the motor.
6. Replace the motor		Firstly, disengage the motor from motor support. Then, sequentially disengage the fan sub-assembly from the motor shaft. Remove the motor from the air inlet and replace with new motor. In which, for the motor with automatic motor support, the motor support shall be removed in advance and then changed to the unit.

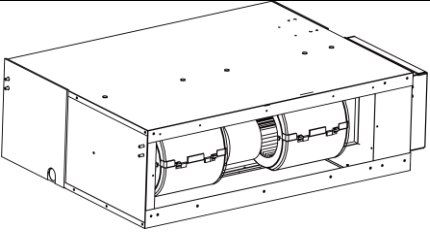
<p>7. Assemble the unit in reverse to the disassembly procedures</p>		<p>Assemble the unit in reverse to the disassembly procedures and energize it for testing.</p>
--	---	--

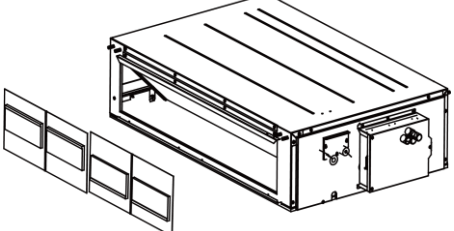
Disassembly of filter screen for return air.		
<p>Remark: Make sure that the power supply is cut off before disassembling and protect all the parts during disassembly. Do not put filter screen near the high temperature heat source.</p>		
Step	Illustration	Handling Instruction
<p>1. Disassembly of filter screen for return air</p>		<p>Compress the filter screen for return air down on the guide slot sponge, and remove according to the direction shown by the arrow. There are 2 filter screens for return air.</p>

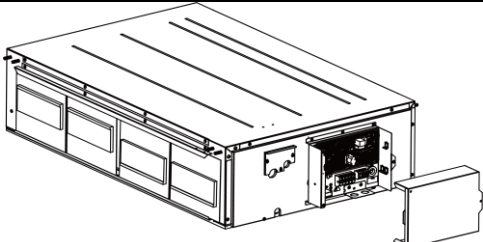
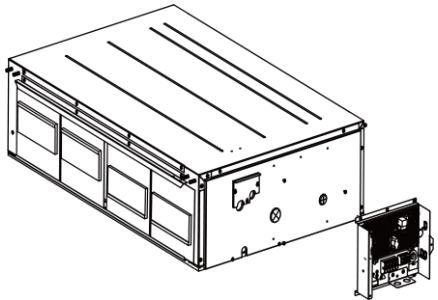
Disassembly of electrical parts box cover panel and electrical parts box		
<p>Remark: Make sure that the power supply is cut off before disassembling and protect all the parts during disassembly, especially the electrical components. Do not dampen or hit them</p>		
Step	Illustration	Handling Instruction
<p>1. Disassembly of electric box cover</p>		<p>Disassemble the screw according to the position shown in the circle and the box and remove the electric box in the direction of the arrow.</p>
<p>2. Disassembly of electric parts box</p>		<p>Disassemble the fastening screw and remove the electrical parts box. (As is shown in the graph, there are 2 fastening screws in the circle and the screws in the direction of arrow shall be disassembled too.)</p>

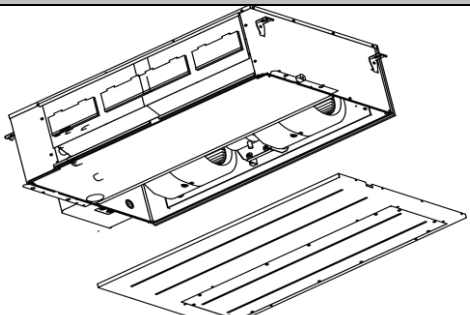
Disassembly of water-containing plate		
<p>Remark: Make sure that the power supply is cut off before disassembling and protect all the parts during disassembly.</p>		
Step	Illustration	Handling Instruction
<p>1. Disassembly of cover plate</p>		<p>Disassemble the fastening screws on the cover plate and remove the cover plate. (As is shown in the graph, circle represents 6 fastening screws under the cover plate and the box represents two fastening screws on water-containing plate symmetrically arranged both on left and right.)</p>

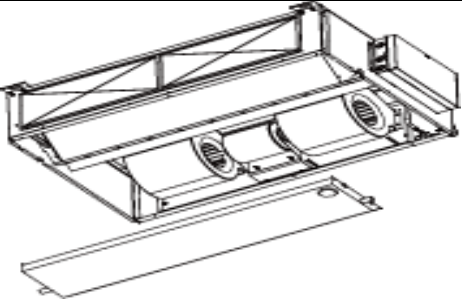
<p>2. Disassembly of water-containing plate</p>		<p>Disassemble the fastening screws on the water-containing plate, pull upward and remove the water-containing plate. Disassembled water-containing plate is shown in the graph.</p>
---	--	--

Disassembly of fan and motor

Remark: Make sure that the power supply is cut off before disassembling and protect all the parts during disassembly.

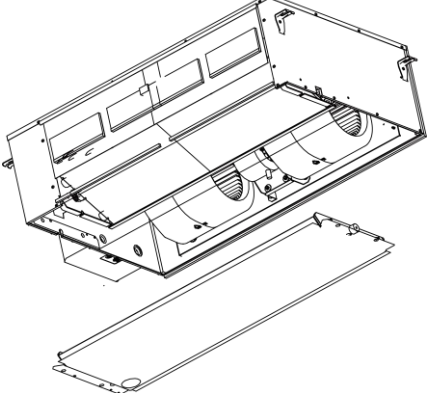
Step	Illustration	Handling Instruction
<p>Disassembly of fan motor</p>		<p>Disassemble the fixing screws on the fan components. (As is shown in Graph 10, circle represents 6 screws.) Disassemble the fastening screws on the fan and motor. Remove the fan. (As is shown in Graph 11, box represents screws.)</p>

Disassembly of evaporator

Remark: Make sure that the power supply is cut off and protect the copper tube and aluminum fin. If the time for disassembly shall be long, put the copper tube under pressurized condition.

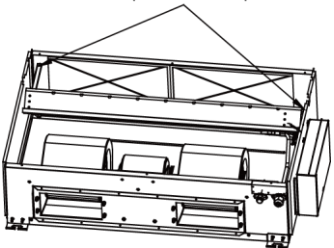
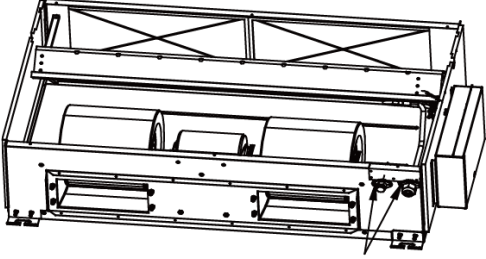
Step	Illustration	Handling Instruction
<p>1. Disassembly of fixing screws on the side panels of evaporator</p>	<p style="text-align: center;">Disassemble of fixing screws on the side panels of evaporator</p> 	<p>Disassemble the fastening screw connecting left and right side panels on the evaporator and the upper cover plate. (As is shown in the arrows direction in Graph.)</p>
<p>2. Disassemble fastening screws connecting evaporator valve seal-plate and joint flange</p>	 <p style="text-align: center;">Disassemble fastening screws connecting evaporator valve seal-plate and joint flange</p>	<p>Disassemble the fastening screws on the valve seal-plate and remove the valve seal-plate. Disassemble the fastening screws on the evaporators joint flange. (As is shown in the graph, box represents fastening screws on seal-plates while circle the fastening screws on joining flange.)</p>

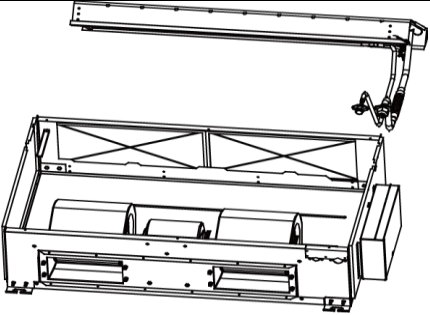
<p>3. Removal of evaporator</p>		<p>Remove the evaporator. Removed evaporator is shown in the graph.</p>
---------------------------------	---	---

4.2.2 Cassette-type Unit

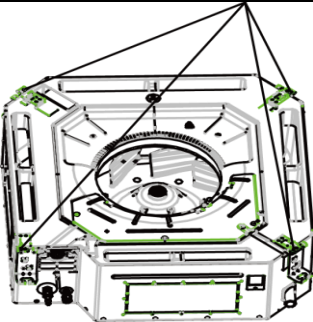
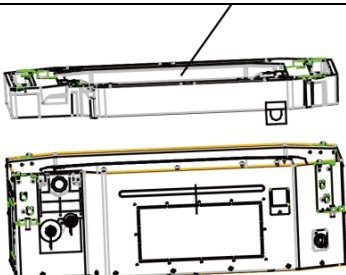
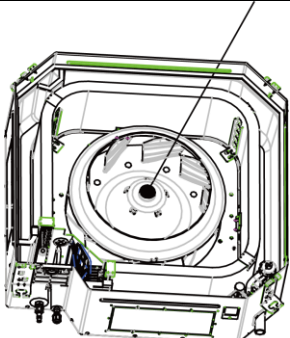
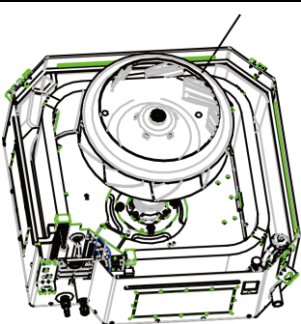
Removal and Assembly of Fan Motor		
Step	Illustration	Handling Instruction
<p>1. Loosen the screws fixing the water tray</p>		<p>Use screwdriver to loosen the screws fixing the water tray</p>
<p>2. Remove the water tray</p>		<p>Remove the water tray</p>
<p>3. Loosen the bolts fixing the fan</p>		<p>Use spanner to loosen the bolts fixing the fan.</p>
<p>4. Remove the fan</p>		<p>Remove the fan</p>

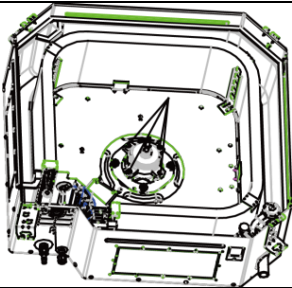
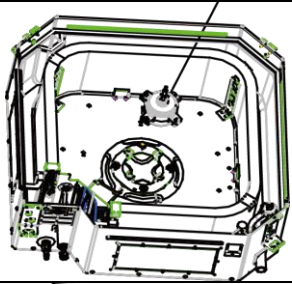
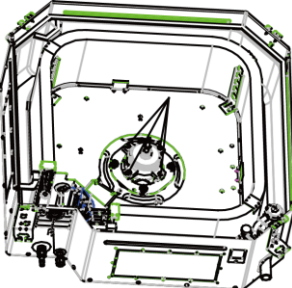
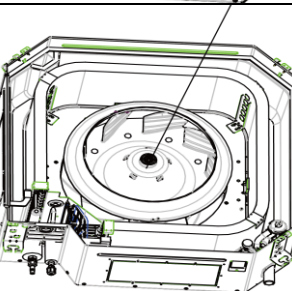
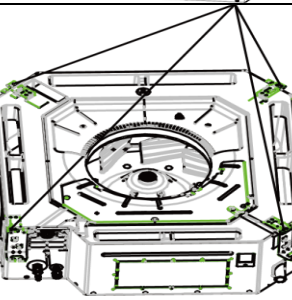
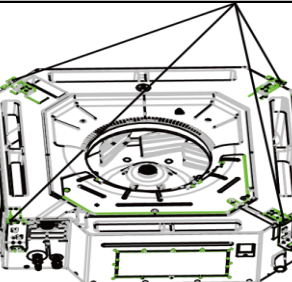
<p>5. Loosen the screws fixing the motor</p>		<p>Use screwdriver to loosen the screws fixing the motor</p>
<p>6. Remove the motor and replace it</p>		<p>Remove the motor and replace it</p>
<p>7. Tighten the screws fixing the motor</p>		<p>Use screwdriver to tighten the screws fixing the motor.</p>
<p>8. Mount the fan and tighten the fixing bolts</p>		<p>Mount the fan and use spanner to tighten the bolts fixing the fan.</p>
<p>9. Mount the water tray and tighten the screws</p>		<p>Use screwdriver to loosen the screws fixing the water tray</p>
<p>Removal and Installation of Drainage Pump</p>		
<p>Step</p>	<p>Illustration</p>	<p>Handling Instruction</p>
<p>1. Loosen the screws fixing the water tray</p>		<p>Use screwdriver to loosen the screws fixing the water tray</p>

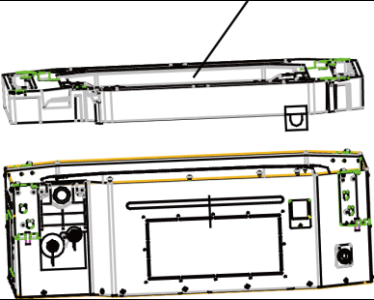
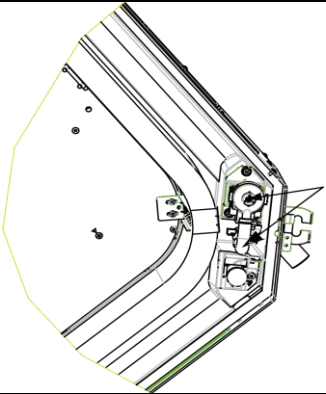
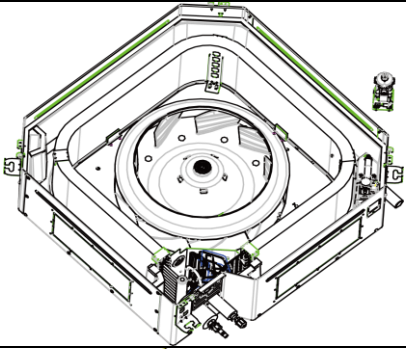
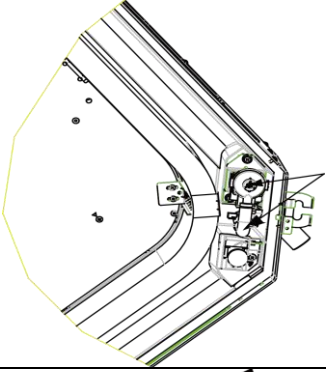
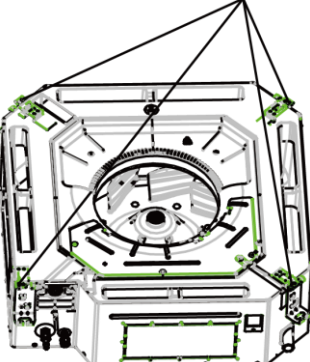
<p>2. Remove the water tray</p>		<p>Remove the water pump and replace it.</p>
<p>3. Pull out the water outlet pipe and loosen the screws fixing the water pump.</p>		<p>Pull out the water outlet pipe and use screwdriver to loosen the screws fixing the water pump.</p>
<p>4. Take out the pump and replace it</p>		<p>Take out the pump and replace it</p>
<p>5. Connect the drainage pipe and tighten the screws fixing the water pump.</p>		<p>Connect the drainage pipe and use screwdriver to tighten the screws fixing the water pump.</p>
<p>6. Mount the water tray and tighten the screws</p>		<p>Use screwdriver to loosen the screws fixing the water tray</p>

4.2.3 Floor Ceiling Type

◆ Model: GTH30K3FI~GTH42K3FI

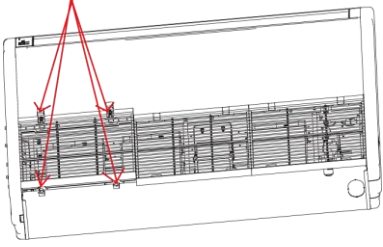
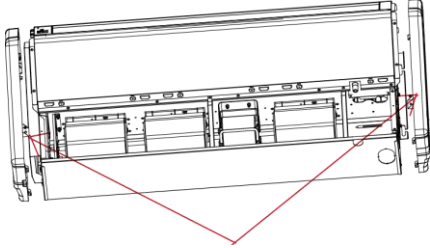
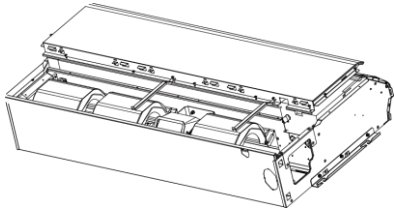
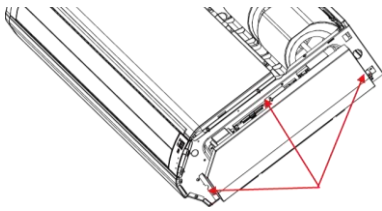
Disassembly of panel grating module		
Remark: Make sure that the power supply is cut off before disassembling and protect all the parts during disassembly. Do not put filter screen near the high temperature heat source.		
Step	Illustration	Handling Instruction
Disassembly of sub-assy of front grill		<ul style="list-style-type: none"> ●Unscrew the 2 clasps of the upper grill and the 2 screws of the clasps. ●Open the grill, disassemble the 2 down clasps to remove the grill.
Disassembly of right and left finishing plates		
Remark: Make sure the power supply is cut off before disassembling and protect all the parts during disassembly. Do not scratch the outer parts.		
Step	Illustration	Handling Instruction
Disassembly of right and left finishing plates		<ul style="list-style-type: none"> ●Disassemble the screws as shown in the graph with screwdriver and then push upward to remove the right and left finishing plates.(As is shown in the graph, arrow represents the position of screws.)
Disassembly of panel parts		
Remark: Make sure the power supply is cut off before disassembling and protect all the parts during disassembly. Do not scratch the outer parts.		
Step	Illustration	Handling Instruction
Disassembly of panel parts		<ul style="list-style-type: none"> ●Unscrew the 3 sides' screws on the cover to remove the cover.
Disassembly of sub-assy of electric box		
Remark: Make sure that the power supply is cut off before disassembling and protect all the parts during disassembly, especially the components inside the box in case of water and hit.		
Step	Illustration	Handling Instruction
Disassembly of electric box cover		<ul style="list-style-type: none"> ●Disassemble 3 screws as shown by the arrow in the graph on left and remove the electric box cover.

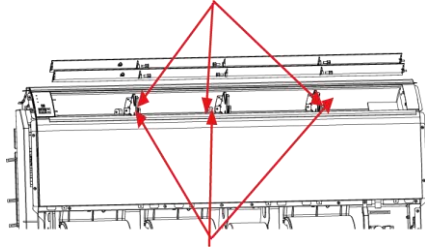
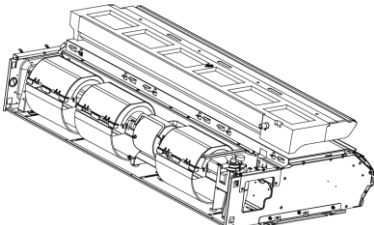
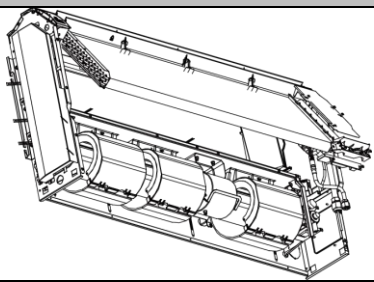
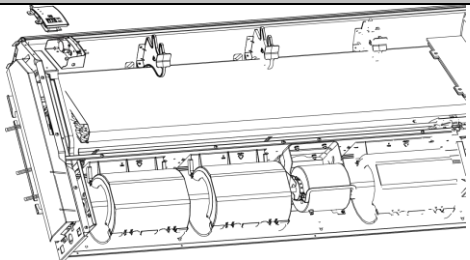
Disassembly of air deflecting plate modules		
Remark: Make sure the power supply is cut off before disassembling and protect all the parts during disassembly, especially the joints of the air deflecting plate.		
Step	Illustration	Handling Instruction
Disassembly of sub-assy of air deflecting plate		<ul style="list-style-type: none"> Remove the air deflecting plates from the air deflecting plate support assembly, and then remove both ends from the air sweeping motor. Joint (As is shown in the graph, arrow represents the support assembly and circle the air sweeping motor joint.)
Disassemble of water-containing plate modules		
Remark: Make sure the power supply is cut off before disassembling and protect all the parts during disassembly.		
Step	Illustration	Handling Instruction
Disassemble of water-containing plate modules		<ul style="list-style-type: none"> Remove the water-containing plate modules.
Disassembly of evaporator components		
Remark: Make sure that the power supply is cut off and protect the copper tube and aluminum fin. If the time for disassembly shall be long, seal the copper tube.		
Step	Illustration	Handling Instruction
Disassembly of evaporator components		<ul style="list-style-type: none"> Unscrew the 6 screws of evaporator, 3 screws of water groove press board and the 2 screws of water board to remove the evaporator.
Disassembly of fixing plate sub-assy for air sweeping fans		
Remark: Make sure that the power supply is cut off before disassembling and protect all the parts during disassembly.		
Step	Illustration	Handling Instruction
Disassembly of fixing plate sub-assy for air sweeping fans		<ul style="list-style-type: none"> Remove the display board, mounting support and mounting plate of swing motor in turn.

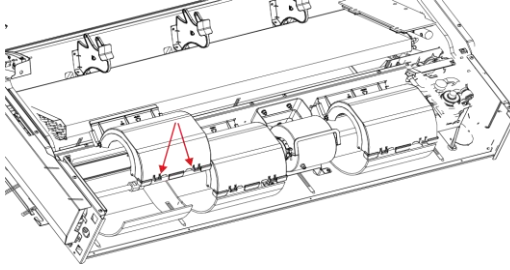
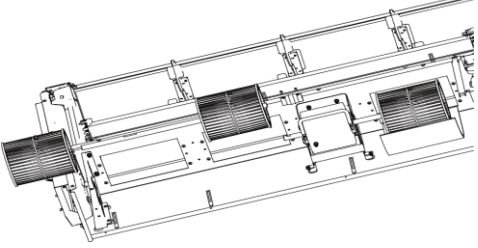
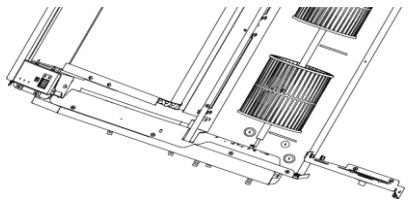
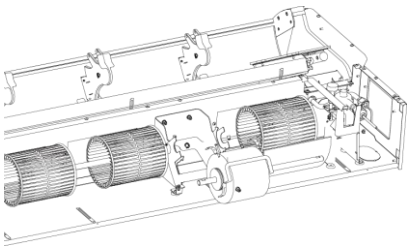
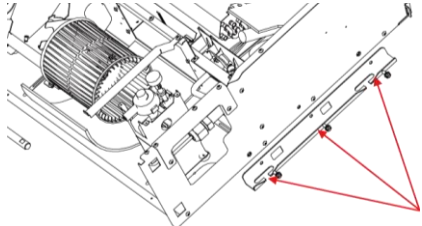
Disassembly of fan and motor components		
Remark: Make sure that the power supply is cut off before disassembling and protect all the parts during disassembly, especially the fastening screws for fans.		
Step	Illustration	Handling Instruction
1. Disassembly of front and back scroll cases		<ul style="list-style-type: none"> ● Press the buckle at the joints of front and back scroll cases with hands and pull upward to remove the front scroll case. Then remove the screws on the back scroll case. Lift the buckle of back scroll case with hands and remove it. (As is shown in the graph, circle represents 2 screws on left and right.)
2. Disassembly of fans		<ul style="list-style-type: none"> ● Unscrew the 2 screws of coupling, take out the rotating shaft and louver, then loosen the tighten screw of louver to remove the louver
3. Disassembly of bearing fixing plates		<ul style="list-style-type: none"> ● Unscrew the 3 screws and 2 nuts of support to remove the mounting support.
4. Disassembly of motor		<ul style="list-style-type: none"> ● Loosen the 2 screws of the motor attaching clamp, remove the motor attaching clamp and motor attaching clamp subassembly to remove the motor.
Disassembly of right and left fixing plates		
Remark: Make sure that the power supply is cut off before disassembling and protect all the parts during disassembly.		
Step	Illustration	Handling Instruction
Disassembly of right and left fixing plates		<ul style="list-style-type: none"> ● Disassemble the bolts on right and left fixing plates with tools. (As is shown by the arrow in the graph.)

◆ Model: GTH09K3FI~GTH24K3FI, GTH48K3FI, GTH60K3FI

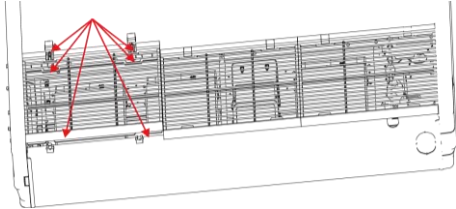
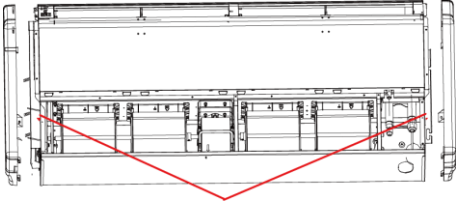
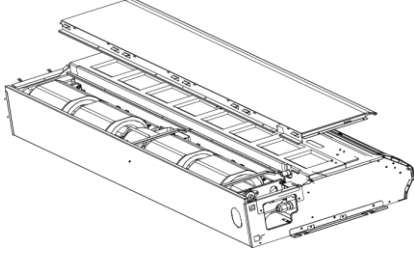
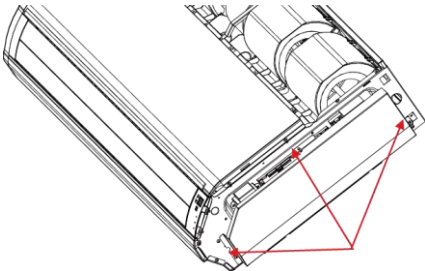
Disassembly of panel grating module		
Remark: Make sure that the power supply is cut off before disassembling and protect all the parts during disassembly. Do not put filter screen near the high temperature heat source.		
Step	Illustration	Handling Instruction
Disassembly of sub-assy of front grill		<ul style="list-style-type: none"> ● Unscrew the 2 clasps of the upper grill and the 2 screws of the clasps. ● Open the grill, disassemble the 2 down clasps to remove the grill
Disassembly of right and left finishing plates		
Remark: Make sure the power supply is cut off before disassembling and protect all the parts during disassembly. Do not scratch the outer parts.		
Step	Illustration	Handling Instruction
Disassembly of right and left finishing plates		<ul style="list-style-type: none"> ● Disassemble the screws as shown in the graph with screwdriver and then push upward to remove the right and left finishing plates. (As is shown in the graph, arrow represents the position of screws.)
Disassembly of panel parts		
Remark: Make sure the power supply is cut off before disassembling and protect all the parts during disassembly. Do not scratch the outer parts.		
Step	Illustration	Handling Instruction
Disassembly of panel parts		<ul style="list-style-type: none"> ● Unscrew the 3 sides' screws on the cover to remove the cover.
Disassembly of sub-assy of electric box		
Remark: Make sure that the power supply is cut off before disassembling and protect all the parts during disassembly, especially the components inside the box in case of water and hit.		
Step	Illustration	Handling Instruction
1. Disassembly of electric box cover		<ul style="list-style-type: none"> ● Disassemble 3 screws as shown by the arrow in the graph on left and remove the electric box cover.

Disassembly of air deflecting plate modules		
Remark: Make sure the power supply is cut off before disassembling and protect all the parts during disassembly, especially the joints of the air deflecting plate.		
Step	Illustration	Handling Instruction
Disassembly of sub-assy of air deflecting plate		<ul style="list-style-type: none"> Remove the air deflecting plates from the air deflecting plate support assembly, and then remove both ends from the air sweeping motor joint (As is shown in the graph, arrow represents the support assembly and circle the air sweeping motor joint.)
Disassemble of water-containing plate modules		
Remark: Make sure the power supply is cut off before disassembling and protect all the parts during disassembly.		
Step	Illustration	Handling Instruction
Disassemble of water-containing plate modules		<ul style="list-style-type: none"> Remove the water-containing plate modules.
Disassembly of evaporator components		
Remark: Make sure that the power supply is cut off and protect the copper tube and aluminum fin. If the time for disassembly shall be long, seal the copper tube.		
Step	Illustration	Handling Instruction
Disassembly of evaporator components		<ul style="list-style-type: none"> Unscrew the 6 screws of evaporator, 3 screws of water groove press board and the 2 screws of water board to remove the evaporator.
Disassembly of fixing plate sub-assy for air sweeping fans		
Remark: Make sure that the power supply is cut off before disassembling and protect all the parts during disassembly.		
Step	Illustration	Handling Instruction
Disassembly of fixing plate sub-assy for air sweeping fans		<ul style="list-style-type: none"> Remove the display board, mounting support and mounting plate of swing motor in turn.

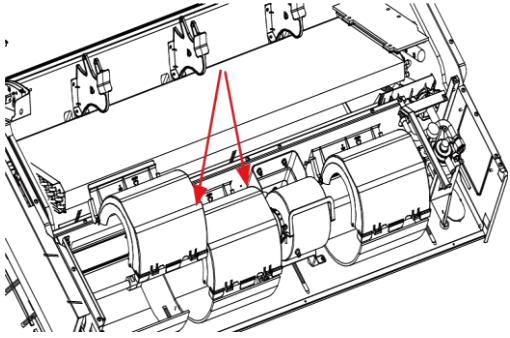
Disassembly of fan and motor components		
Remark: Make sure that the power supply is cut off before disassembling and protect all the parts during disassembly, especially the fastening screws for fans.		
Step	Illustration	Handling Instruction
1. Disassembly of front and back scroll cases		<ul style="list-style-type: none"> ● Press the buckle at the joints of front and back scroll cases with hands and pull upward to remove the front scroll case. Then remove the screws on the back scroll case. Lift the buckle of back scroll case with hands and remove it. (As is shown in the graph, circle represents 2 screws on left and right.)

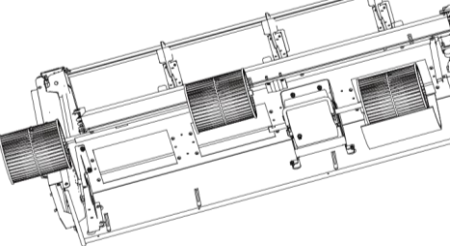
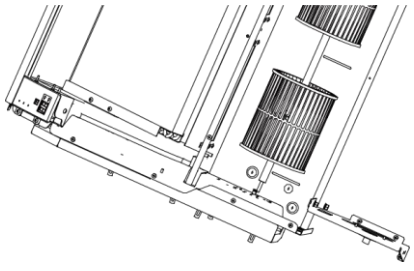
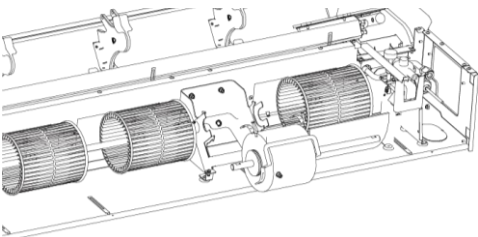
Disassembly of fan and motor components		
Remark: Make sure that the power supply is cut off before disassembling and protect all the parts during disassembly, especially the fastening screws for fans.		
Step	Illustration	Handling Instruction
2. Disassembly of fans		<ul style="list-style-type: none"> ● Unscrew the 2 screws of coupling, take out the rotating shaft and louver, then loosen the tighten screw of louver to remove the louver.
3. Disassembly of bearing fixing plates		<ul style="list-style-type: none"> ● Unscrew the 3 screws and 2 nuts of support to remove the mounting support
4. Disassembly of motor		<ul style="list-style-type: none"> ● Loosen the 2 screws of the motor attaching clamp, remove the motor attaching clamp and motor attaching clamp subassembly to remove the motor.

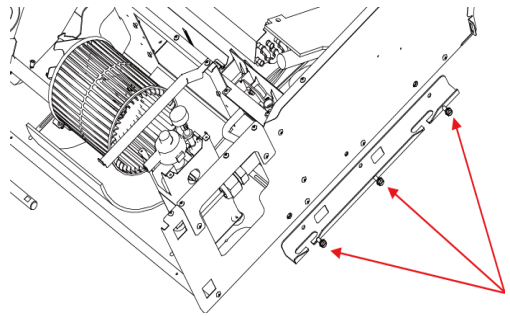
Disassembly of right and left fixing plates		
Remark: Make sure that the power supply is cut off before disassembling and protect all the parts during disassembly.		
Step	Illustration	Handling Instruction
Disassembly of right and left fixing plates		<ul style="list-style-type: none"> ●Disassemble the bolts on right and left fixing plates with tools. (As is shown by the arrow in the graph.)

5 EXPLODED VIEWS AND SPARE PART LIST

5.1 Outdoor Unit

◆ Model: GUHD09NK3FO/GUHD12NK3FO Exploded Views and spare parts list:

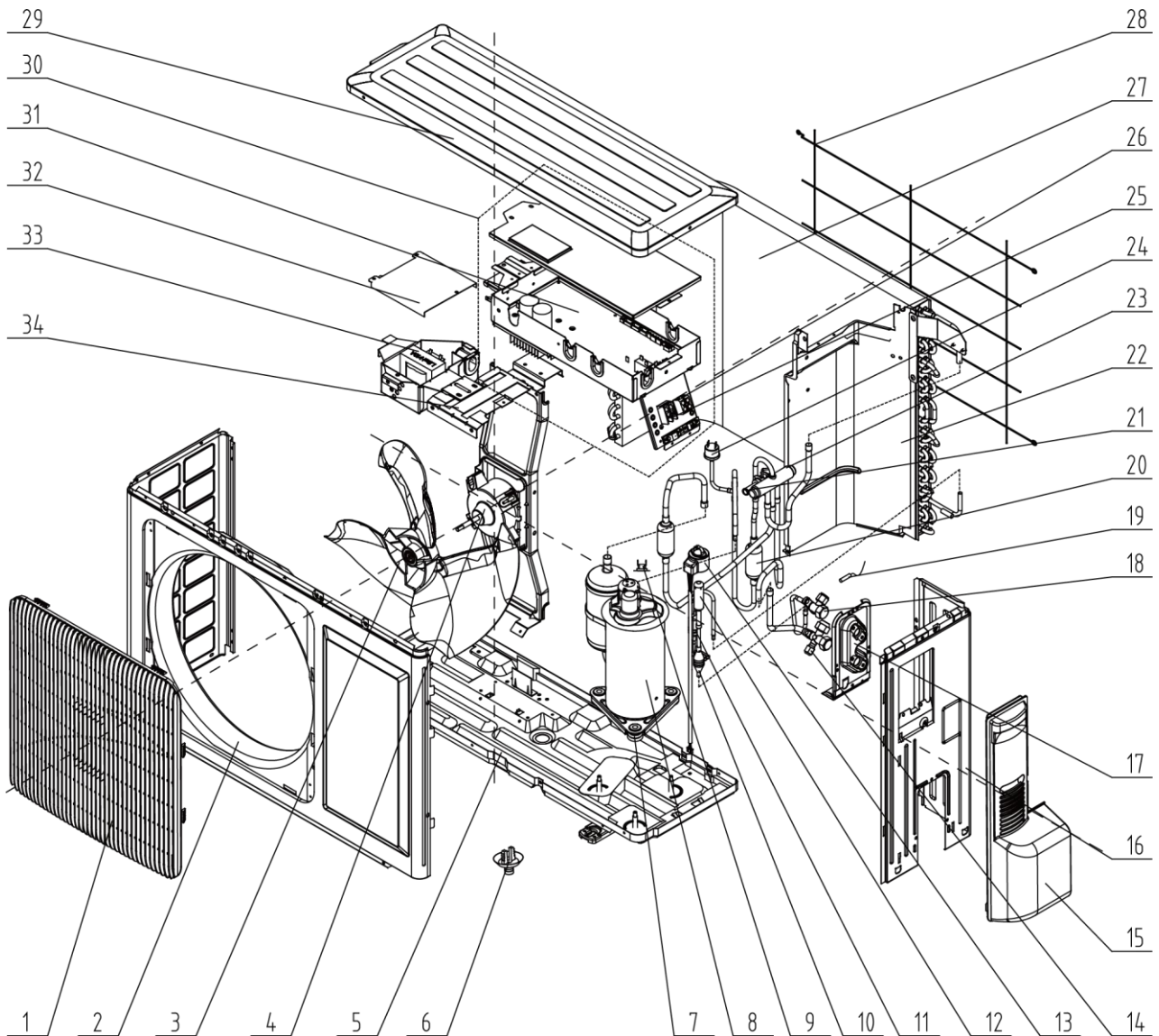

NO.	Name of Part	GUHD09NK3FO		GUHD12NK3FO	
		Product Code	CF090W0630	Product Code	CF090W0640
		Part Code	Quantity	Part Code	Quantity
1	Front Grill	22413433	1	'22413433	1
2	Front Panel	0153303204P	1	'0153303204P	1
3	Axial Flow Fan	'10333012	1	'10333012	1
4	Brushless DC Motor	15709400007	1	'15709400007	1
5	Chassis Sub-assy	0280301701P	1	0280301701P	1
6	Drainage Connector	'06123401	1	'06123401	1
7	Compressor Gasket	'76710302	3	'76710302	3
8	Compressor and Fittings	00103896	1	'00103896	1
9	Compressor Overload Protector(External)	'00180030or 00183031or 00183032		'00180030or 00183031or 00183032	
10	Strainer	0721304401	1	'0721304401	1
11	Strainer	'07415200002	1	'07415200002	1
12	Electronic Expansion Valve	'43042800008	1	'43042800008	1
13	Electric Expand Valve Fitting	'4304413208	1	'4304413208	1
14	Valve	'07100005	1	'07100005	1
15	Big Handle	'26233433	1	'26233433	1
16	Right Side Plate Assy	'0130200404	1	'0130200404	1
17	Valve Support	'01713041	1	'01713041	1
18	Cut off Valve	'07130239	1	'07130239	1
19	Temperature Sensor	'39000310G	1	'39000310G	1
20	Silencer	'07245007	1	'07245007	1
21	Magnet Coil	'4300040033	1	'4300040033	1
22	Clapboard Sub-Assy	'01233034	1	'01233034	1
23	4-Way Valve	'430004022	1	'430004022	1
24	Pressure Protect Switch	'46020003	1	'46020003	1
25	Terminal Board	4201115404	1	'4201115404	1
26	Terminal Board	'420101852	1	'420101852	1
27	Condenser Assy	'01125200023	1	'01125200023	1
28	Rear Grill	'01473057	1	'01473057	1
29	Top Cover Plate	'01253442	1	'01253442	1
30	Electric Box Assy	01395200257	1	'01395200256	1
31	Main Board	30224000032	1	'30224000033	1
32	Cover of Reactor Box	'01413029	1	'01413029	1
33	Reactor	'43130185	1	'43130185	1
34	Motor Support Sub-Assy	'01703101	1	'01703101	1

◆ Model: GUHD18NK3FO Exploded Views and spare parts list:

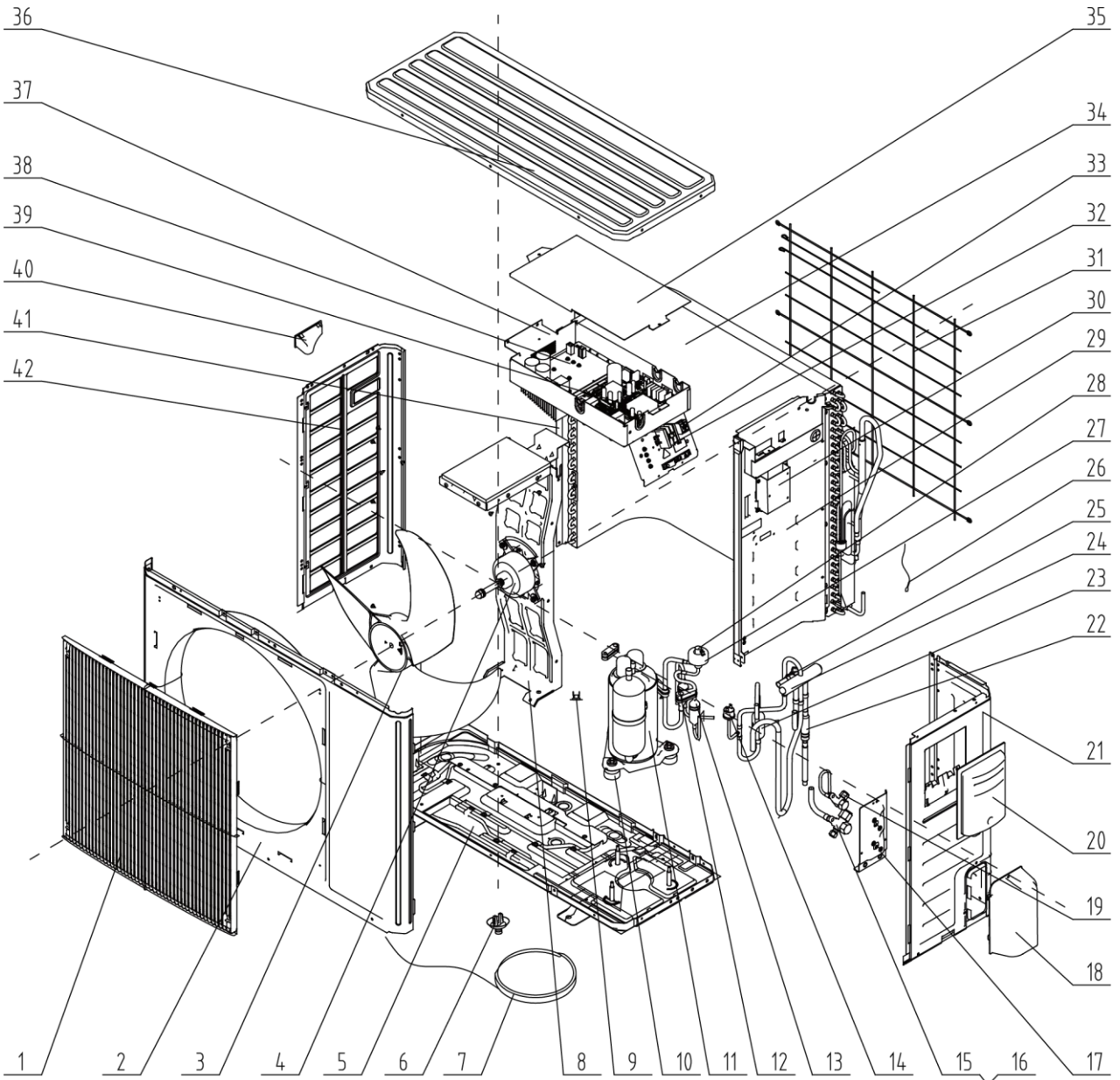

NO.	Name of Part	GUHD18NK3FO	
		Product Code	CF090W0650
		Part Code	Quantity
1	Front Grill	'22415002	1
2	Front Panel	01535013	1
3	Axial Flow Fan	'10335008	1
4	Fan Motor	1570280204	1
5	Chassis Sub-assy	01195200015P	1
6	Drainage Connector	'06123401	1
7	Electrical Heater	'7651300403	1
8	Motor Support Assy	01805200173	1
9	Compressor Overload Protector(External)	'00180030	1
10	Compressor Gasket	'76710247	3
11	Compressor and Fittings	00105249	1
12	Strainer	'0721004501	1
13	Strainer	'07220019	1
14	Pressure Protect Switch	'46020003	1
15	Cut off Valve Sub-Assy	'07133060	1
16	Cut off Valve	'071302392	1
17	Valve Support Assy	'01715010P	1
18	Valve Cover	22245002	1
19	Cut off Valve	'07130239	1
20	Handle	'26235254	1
21	Right Side Plate	'01305094	1
22	Strainer	'07212403	1
23	Silencer	'07245007	1
24	4-Way Valve	'430004032	1
25	Magnet Coil	'4300040033	1
26	Temperature Sensor	3900028020G	1
27	Electric Expand Valve Fitting	4300876706	1
28	Electronic Expansion Valve	'07134601	1
29	Clapboard Sub-Assy	'01232902	1
30	Supporter	'01805405	1
31	Rear Grill	'01473043	1
32	Terminal Board	'420111451	1
33	Terminal Board	'420101852	1
34	Condenser Assy	'01113386	1
35	Electric Box Cover	01425200044	1
36	Coping	'01255005	1
37	Electric Box Assy	01395200177	1
38	Main Board	30221000009	1
39	Main Board	30224000024	1
40	Left Handle	'26235401	1
41	Supporting Board(Condenser)	'01795010	1
42	Left Side Plate	'01305093P	1

◆ Model: GUHD24NK3FO/ GUHD30NK3FO Exploded Views and spare parts list:

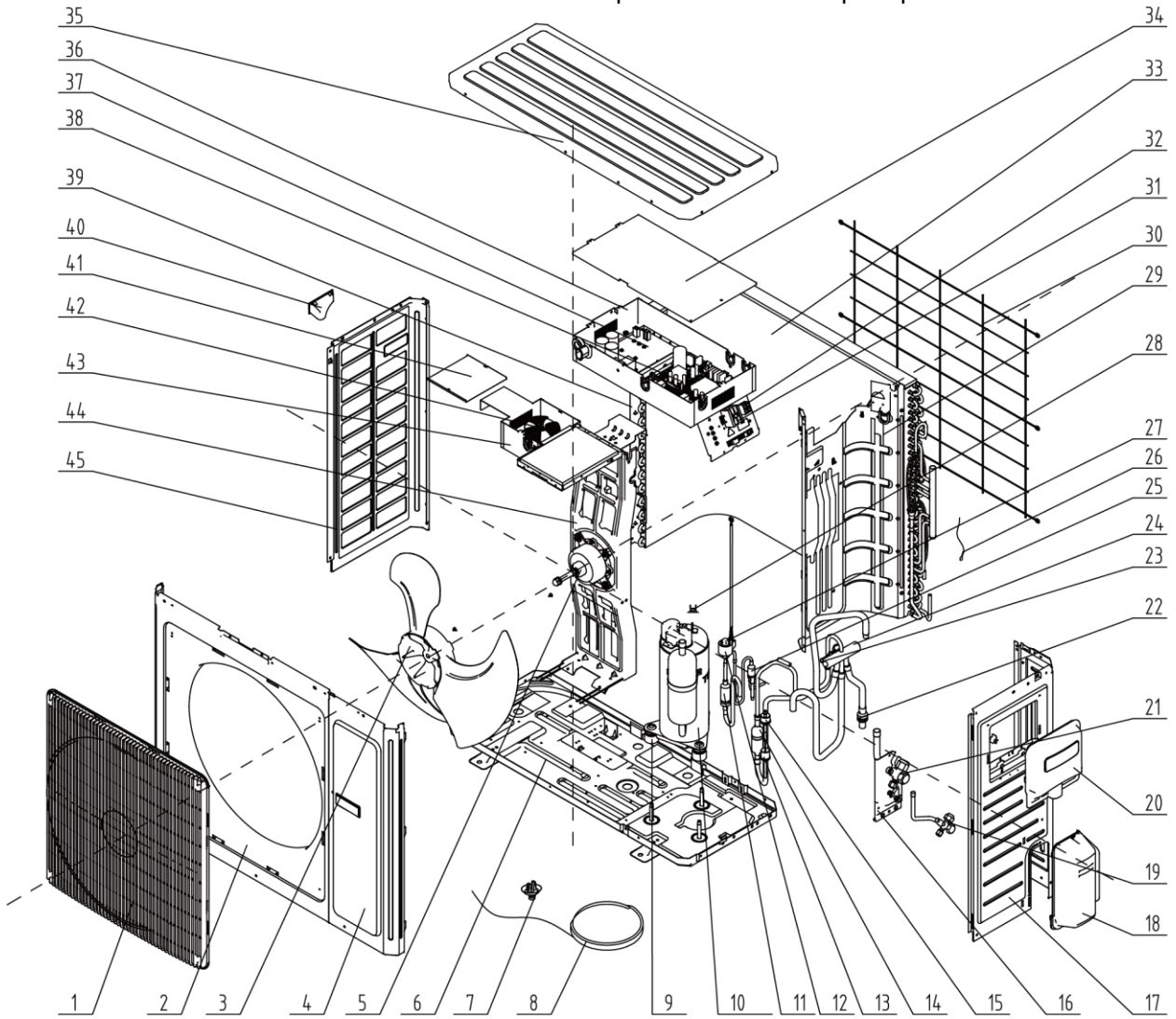

NO.	Name of Part	GUHD24NK3FO		GUHD30NK3FO	
		Product Code	CF090W0660	Product Code	CF090W0670
		Part Code	Quantity	Part Code	Quantity
1	Front Grill	'22415003	1	'22415003	1
2	Cabinet	'01435004P	1	'01435004P	1
3	Axial Flow Fan	10335014	1	'10335014	1
4	Front Side Plate	'01305086P	1	'01305086P	1
5	Fan Motor	'15702802	1	'15702802	1
6	Chassis Sub-Assy	0119520001301P	1	'01195200013P	1
7	Drainage Connector	'06123401	1	'06123401	1
8	Electrical Heater(Compressor)	'7651873209	1	'7651873209	1
9	Compressor Gasket	'76713066	3	'76713066	3
10	Compressor and Fittings	0010505701	1	'0010505701	1
11	Bidirection Strainer	'07220016	1	'07220016	1
12	Electric Expand Valve Fitting	'4304413208	1	'4304413208	1
13	Pressure Protect Switch	'4602000902	1	'4602000902	1
14	Silencer	'07245012	1	'07245012	1
15	Pressure Protect Switch	'46020003	1	'46020003	1
16	Valve Support Sub-Assy	01715020	1	'0171501201P	1
17	Right Side Plate Sub-Assy	01315200069P	1	'01315200069P	1
18	Valve Cover	22245003	1	'22245003	1
19	Valve	'07100005	1	'07100005	1
20	Big Handle	'26235001	1	'26235001	1
21	Cut off Valve	'07133157	1	'07133157	1
22	Strainer	'07215201	1	'07215201	1
23	Magnet Coil	'4300040033	1	'4300040033	1
24	4-way Valve	'4300008201	1	'4300008201	1
25	Strainer	'07225088	1	'07225088	1
26	Temperature Sensor	3900028020G	1	'3900028020G	1
27	Electronic Expansion Valve	'07334447	1	'07334447	1
28	Compressor Overload Protector(External)	'00180030	1	'00180030	1
28	Compressor Overload Protector(External)	00183051	1	'00183051	1
28	Compressor Overload Protector(External)	00183032	1	'00183032	1
29	Clapboard	01245280	1	'01245271	1
30	Rear Grill	'01475008	1	'01475008	1
31	Terminal Board	'420111451	1	'420111451	1
32	Terminal Board	'420101852	1	'420101852	1
33	Condenser Assy	01125200184	1	'01125200182	1
34	Electric Box Cover	'01425281	1	'01425281	1
35	Top Cover Sub-Assy	'01255007	1	'01255007	1
36	Electric Box Assy	01395200173	1	'01395200178	1
37	Main Board	30221000010	1	'30221000010	1
38	Main Board	30224000026	1	'30224000038	1
39	Condenser Support Plate	'01175092	1	'01175092	1
40	Left Handle	'26235401	1	'26235401	1
41	Electric Box Cover	'01425279	1	'01425279	1
42	PFC Inductance	'43128003	1	'43128003	1
43	Inductance Box Sub-Assy	01395200176	1	'01395200176	1
44	Motor Support Assy	01805200166	1	'01805200160	1
45	Left Side Plate	'01305043P	1	'01305043P	1

◆ Model: GUHD36NK3FO Exploded Views and spare parts list:

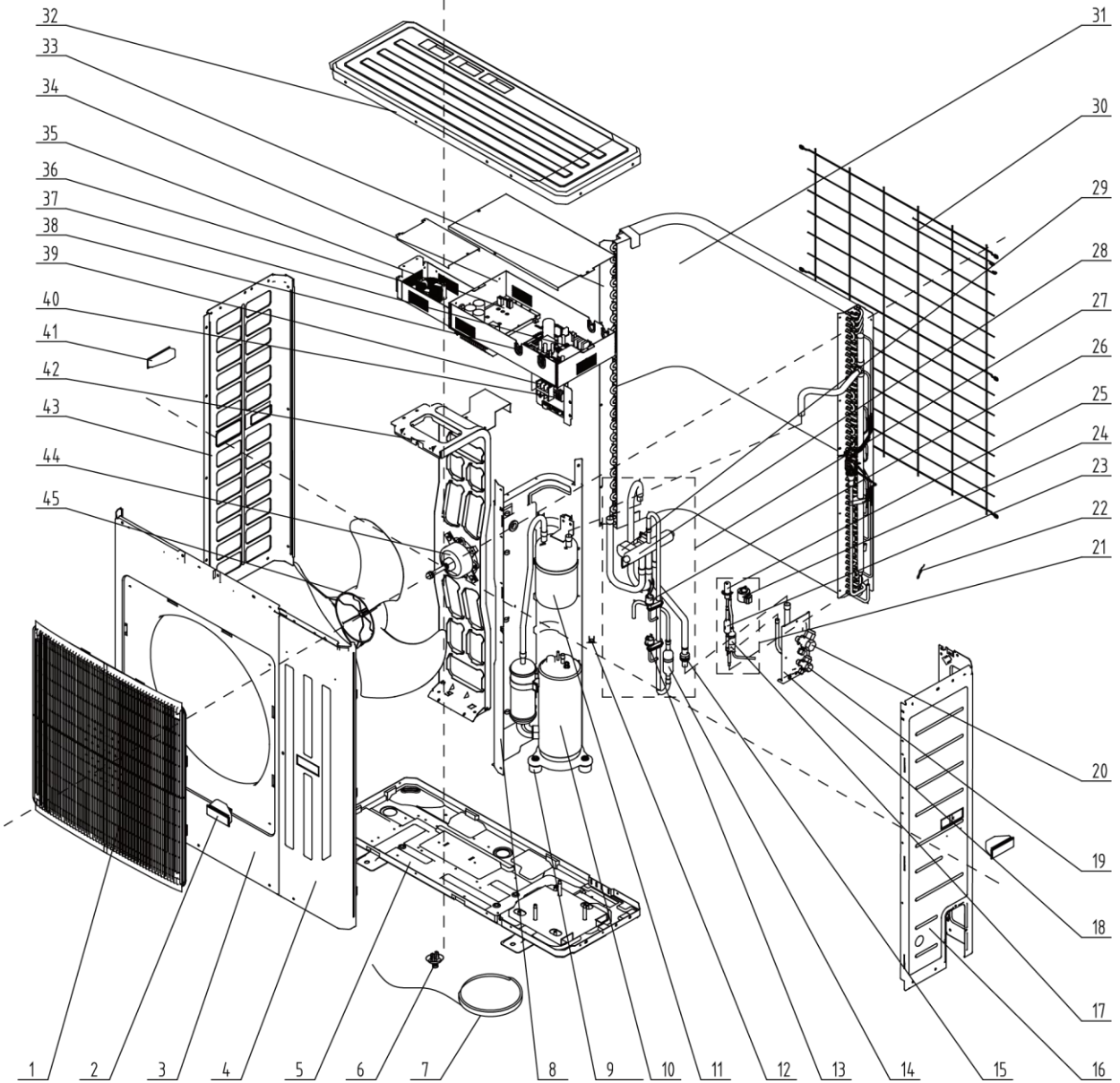

NO.	Name of Part	GUHD36NK3FO	
		Product Code	CF090W0680
		Part Code	Quantity
1	Front Grill	'22415005	1
2	Handle	'26235253	2
3	Cabinet	'01435007P	1
4	Front Side Plate Sub-Assy	'01305508	1
5	Chassis Sub-Assy	'01195315P	1
6	Drainage Joint	'26113009	1
7	Electrical Heater(Compressor)	'7651873209	1
8	Clapboard Sub-Assy	'01245253	1
9	Compressor Gasket	'76713066	3
10	Compressor	'00205200003	1
11	Gas-liquid Separator Sub-Assy	'07255201	1
12	Compressor Overload Protector(External)	00180030or 0183032or 00183051	1
13	Pressure Switch	'46020003	1
14	Muffler	'07245012	1
15	Filter	'07215201	1
16	Right Side Plate Sub-Assy	` 01315200068P	1
17	Filter	'07210045	1
18	Valve Support Sub-Assy	' 01805200222P	1
19	Cut-off Valve	'071302391	1
20	Cut-off Valve	'07133157	1
21	Electronic Expansion Valve Sub-Assy	` 43045200007	1
22	Temperature Sensor	'39008000049G	1
23	Filter	'07213032	1
24	Electronic Expansion Valve Coil	' 4300010839	1
25	Electronic Expansion Valve	` 07334194	1
26	Pressure Switch	'4602000902	1
27	4-Way Valve Assy	` 04045200038	1
28	4-way Valve	'43000338	1
29	Magnet Coil	'4300040033	1
30	Rear Grill	'01475012	1
31	Condenser Assy	'01125200196	1
32	Top Cover	'0125500901P	1
33	Condenser Support Plate	'01895242	1
34	Electric Box Assy	'01395200180	1
35	Main Board	'30221000003	1
36	PFC Inductance	'43120011	1
37	Main Board	'30224000037	1
38	Filter Board	'30221000007	1
39	Terminal Board	'42011242	1
40	Terminal Board	'420101852	1
41	Left Handle	'26235401	1
42	Motor Support Sub-Assy	` 01805200190	1
43	Left Side Plate	'01305064P	1
44	Fan Motor	'1570280201	1
45	Axial Flow Fan Blade	'10335010	1

◆ Model: GUHD42NK3FO Exploded Views and spare parts list:

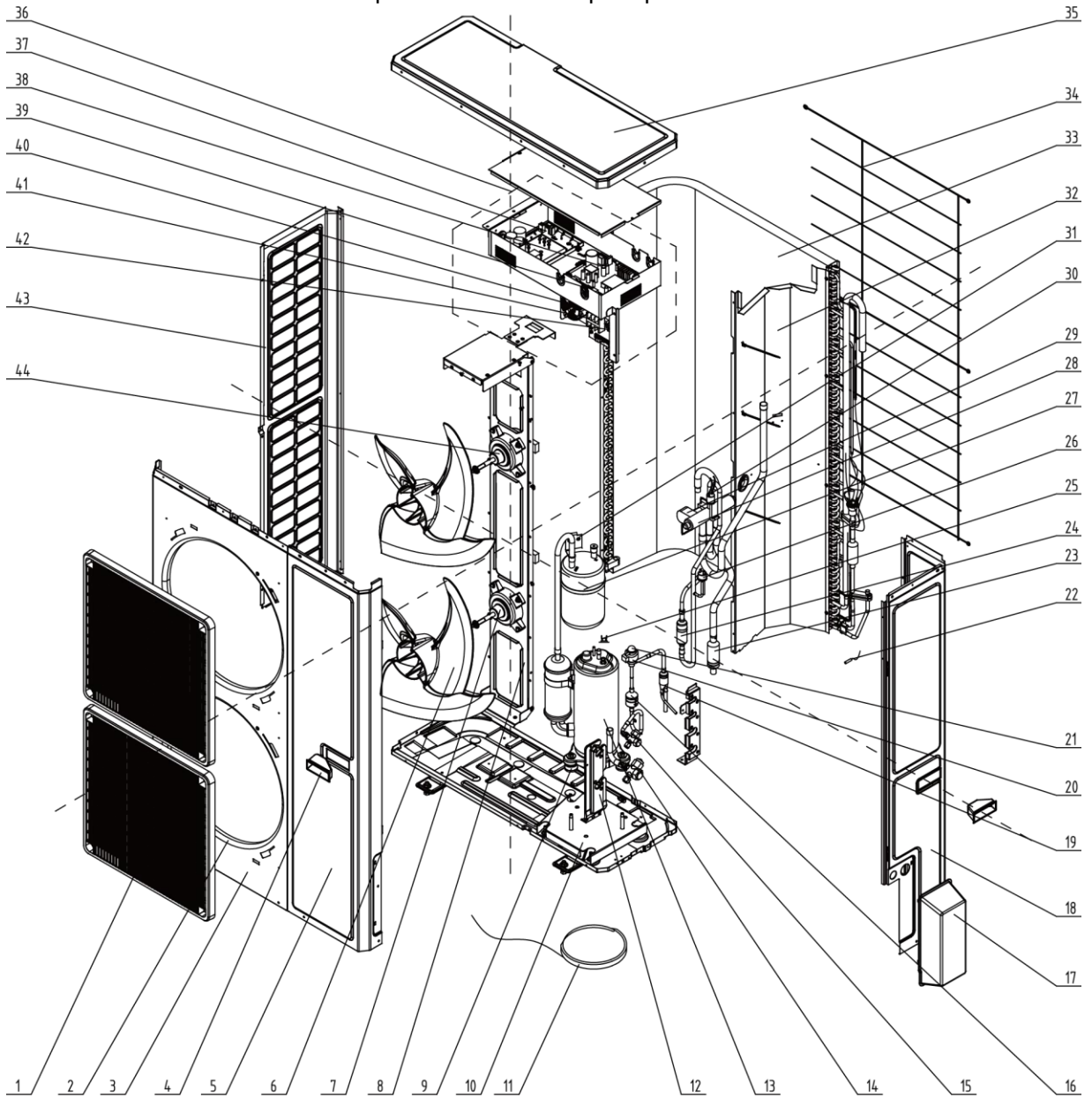

NO.	Name of Part	GUHD42NK3FO	
		Product Code	CF090W0700
		Part Code	Quantity
1	Front Grill	'01575200001	2
2	Diversion Circle	'10474100001	2
3	Cabinet	'01514100002P	1
4	Handle	'26235253	2
5	Front Side Plate	'01314100021P	1
6	Axial Flow Fan	'10434100003	2
7	Fan Motor	'15704115	1
8	Motor Support Sub-Assy	'01805200185	1
9	Compressor Gasket	'76713066	3
10	Chassis Sub-assy	'01195200020P	1
11	electrical heater	'76518732	1
12	Valve Support Sub-Assy	'01805200204P	1
13	Compressor	'00205200003	1
14	Cut off Valve	'07133844	1
15	Cut off Valve	'07130209	1
16	Filter	'07415210	1
17	Valve Cover	'26904100056	1
18	Rear Side Plate	'01314100020P	1
19	Strainer	'07210045	1
20	Electronic Expansion Valve	'07334194	1
21	Electric Expand Valve Fitting	'4300010839	1
22	Temperature Sensor	'3900028025G	1
23	Strainer	'07411100014	1
	Silencer	'07245012	1
24	Silencer	'07245012	1
25	Compressor Overload Protector(External)	'00180030	1
25	Compressor Overload Protector(External)	'00183051	1
25	Compressor Overload Protector(External)	'00183032	1
25	Compressor Overload Protector(External)	'00183031	1
26	Pressure Protect Switch	'46020003	1
27	Gas-liquid Separator Sub-Assy	'07255201	1
28	4-way Valve	'43000338	1
29	Magnet Coil	'4300040032	1
30	Pressure Protect Switch	'4602000902	1
31	Wire Clamp	'02145008	1
32	Clapboard	'01245200007	1
33	Condenser Assy	'01125200197	1
34	Rear Grill	'01574100004	1
35	Coping	'01264100008P	1
36	Electric Box Assy	01395200181	1
37	Main Board	'30221000003	1
38	Main Board	'30224000036	1
39	Filter Board	'30221000007	1
40	PFC Inductance	'43120011	1
41	Terminal Board	'42011242	1
42	Terminal Board	'420101852	1
43	Left Side Plate	'01314100013P	1
44	Fan Motor	'1570411501	1

◆ Model: GUHD48NK3FO Exploded Views and spare parts list:

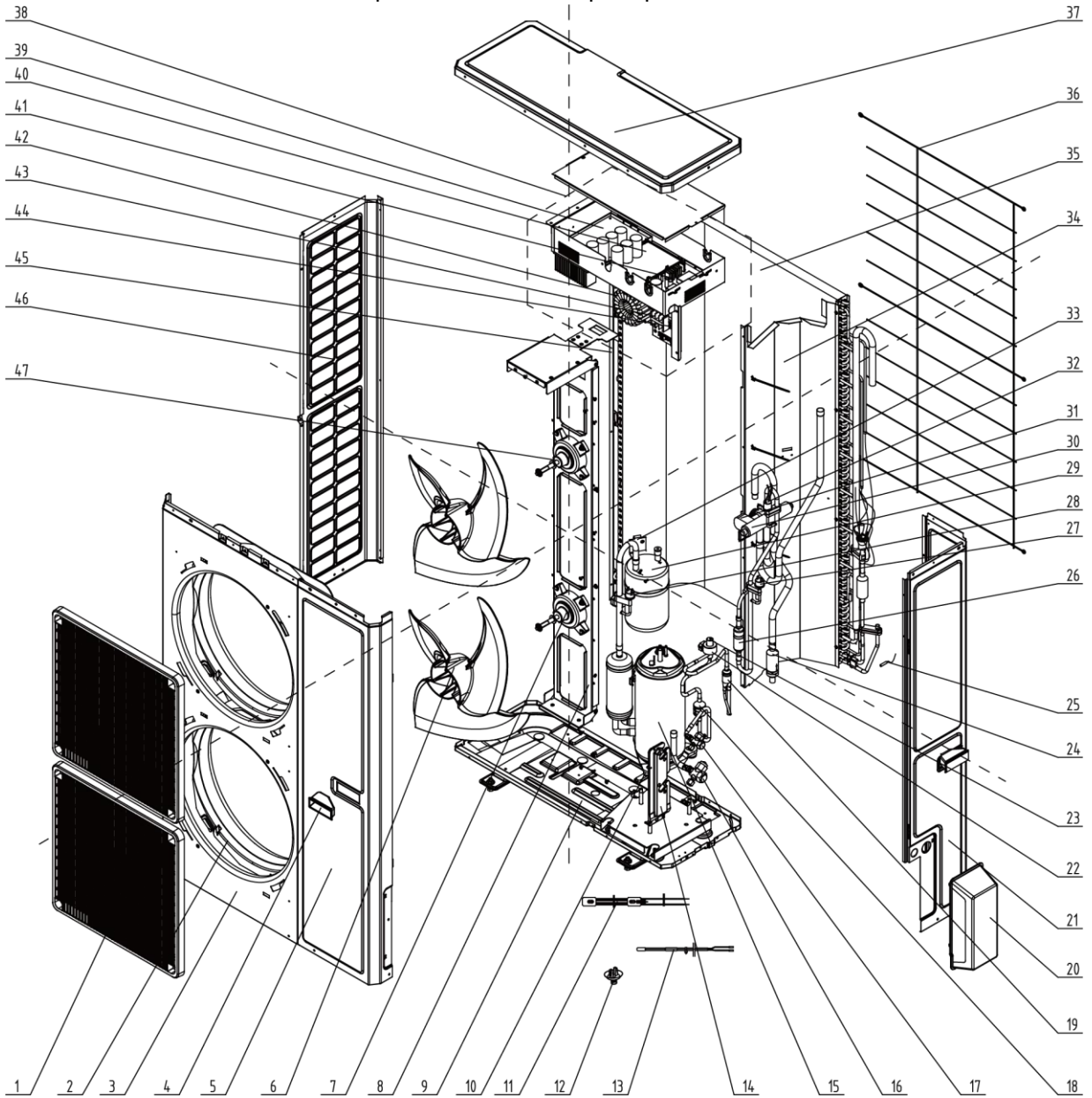

NO.	Name of Part	GUHD48NK3FO	
		Product Code	CF090W0720
		Part Code	Quantity
1	Front Grill	'01575200001	2
2	Diversion Circle	'10474100001	2
3	Cabinet	'01514100002P	1
4	Handle	'26235253	2
5	Front Side Plate	'01314100021P	1
6	Axial Flow Fan	'10434100003	2
7	Fan Motor	'15704115	1
8	Motor Support Sub-Assy	'01805200202	1
9	Chassis Sub-assy	'01195200020P	1
10	Compressor Gasket	'76710247	3
11	electrical heater	'76518732	1
12	Drainage Joint	'26113009	1
13	Electrical Heater	'765100047	1
14	Valve Support Sub-Assy	'01805200204P	1
15	Compressor	'00204100001	1
16	Cut off Valve	'07133844	1
17	Cut off Valve	'07130209	1
18	Filter	'07415210	1
19	Strainer	'07210045	1
20	Valve Cover	'26904100056	1
21	Rear Side Plate	01314100020P	1
22	Electronic Expansion Valve	'07335283	1
23	Electric Expand Valve Fitting	'4304001902	1
24	Strainer	'07411100014	1
25	Temperature Sensor	'3900028025G	1
26	Silencer	'07245012	1
27	Pressure Protect Switch	'46020003	1
28	Pressure Protect Switch	'46020007	1
29	Gas-liquid Separator Sub-Assy	'0722501801	1
30	4-way Valve	'43000338	1
31	Magnet Coil	'4300040032	1
32	Pressure Protect Switch	'4602000902	1
33	Wire Clamp	'02145008	1
34	Clapboard	'0124520000701	1
35	Condenser Assy	'01125200213	1
36	Rear Grill	'01574100004	1
37	Coping	'01264100008P	1
38	Electric Box Assy	01395200255	1
39	Main Board	'30228000005	1
40	Filter Board	'30228000006	1
41	Main Board	'30224000035	1
42	Inductance	'43120122	1
43	Terminal Board	'42011242	1
44	Terminal Board	'420101852	1
45	Supporting Strip	'01894100010	1
46	Left Side Plate	'01314100013P	1
47	Fan Motor	'1570411501	1

5.2 Indoor Unit

5.2.1 Duct Type

◆ Model: GFH09K3FI exploded view and spare parts list

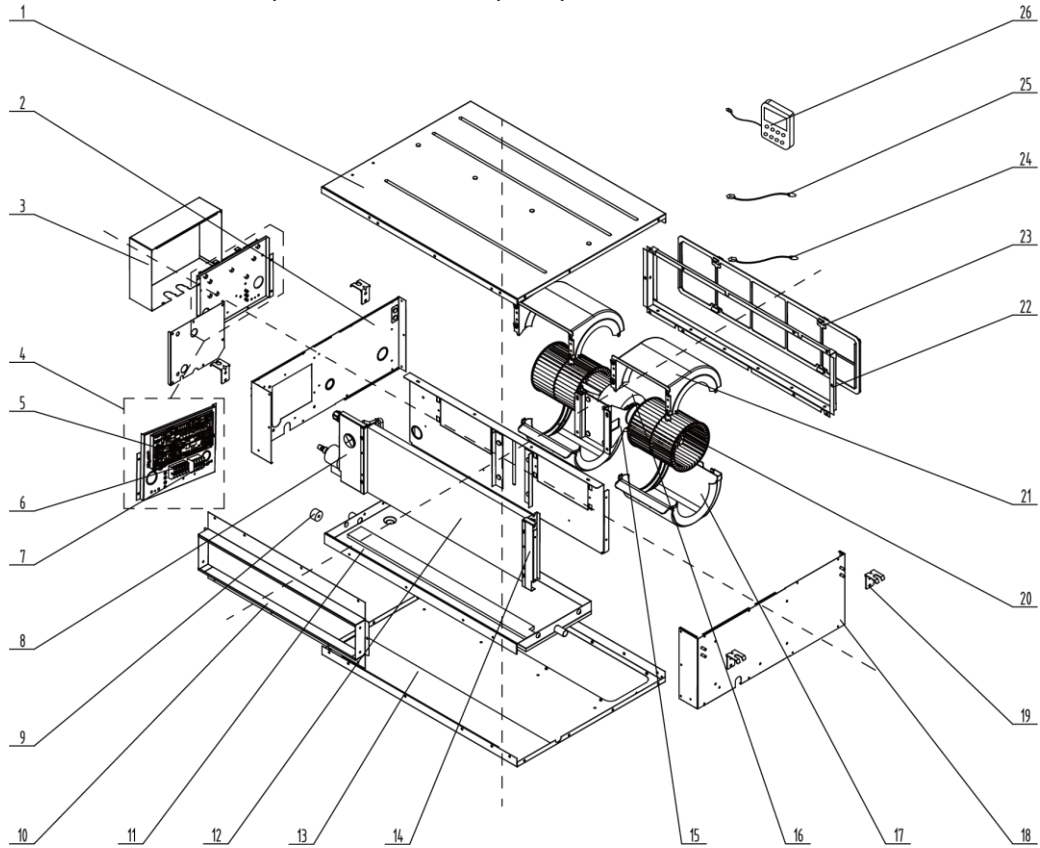

NO.	Name of Part	GFH09K3FI	
		Product Code	CF060N0420
		Part Code	Quantity
1	Top Cover Board Assy	'01264176	1
2	Electric Box Cover	'01425200050	1
3	Left Side Plate Assy	'01315200072	1
4	Electric Box Assy	'01395200239	1
5	Main Board	'30224000030	1
6	Terminal Board	'42010194	1
7	Terminal Board	'4201025301	1
8	Left Evaporator Support	'01094122	1
9	Choke Plug of Drain Pipe	'76712455	1
10	Air intake side-board Sub-assy	'01494118	1
11	Water Tray Assy	01285200028	1
12	Evaporator Assy	01025200066	1
13	Lower Cover Plate Sub-Assy	01265200091	1
14	Right Support of Evaporator	'01094121	1
15	Supporter	'01804100140	1
16	Brushless DC Motor	'15704100001	1
17	Propeller Housing	'22202029	2
18	Right Side Plate Assy	'01314175	1
19	Hook	'02112446	4
20	Centrifugal fan	'10319051	2
21	Front Volute Casing	'22202030	2
22	side plate sub- assy of return air frame	'02225234	1
23	Filter	'11725202	1
24	Temperature Sensor	'390001921G	1
25	Ambient Temperature Sensor	'3900012123	1
26	Display Board	'30294000007	1

◆ Model: GFH12K3FI/GFH18K3FI exploded view and spare parts list

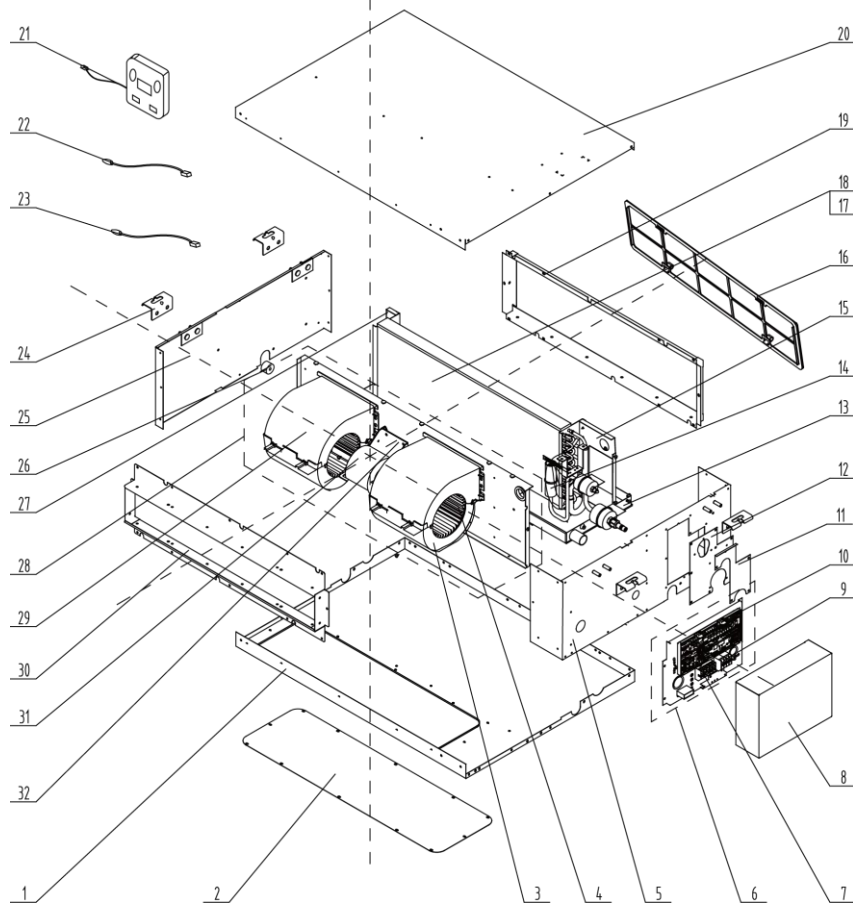

NO.	Name of Part	GFH12K3FI		GFH18K3FI	
		Product Code	CF060N0430	Product Code	CF060N0440
		Part Code	Quantity	Part Code	Quantity
1	Bottom Cover Plate	'01265409	1	'01265409	1
2	Cover Of Air-In	'01258650	1	'01258650	1
3	Propeller Housing	'22202029	2	'22202029	2
4	Centrifugal fan	'10319051	2	'10319051	2
5	Left Side Plate Sub-Assy	'01315200062	1	01315200062	1
6	Electric Box Assy	'01395200239	1	'01395200239	1
7	Terminal Board	'42010194	1	'42010194	1
8	Electric Box Cover	'01425200050	1	01425200050	1
9	Terminal Board	'4201025301	1	4201025301	1
10	Main Board	'30224000030	1	30224000030	1
11	Seal Of Connection Pipe	0	0	0	0
12	Seal Of Connection Pipe	0	0	0	0
13	Water Tray Assy	'01285269	1	'01285269	1
14	Strainer	'07212121	1	'07212121	1
15	left Supporting Board sub-assy of evaporator	'01805280	1	'01805280	1
16	Filter	'11725202	1	'11725202	1
17	Evaporator Assy	'01025200057	1	'01025200053	1
18	Evaporator Assy	'01025401	1	'01025394	1
19	side plate sub-assy of return air frame	'02225234	1	'02225234	1
20	Top Cover Board Sub-assy	'01265200095	1	'01265200095	1
21	Display Board	'30294000007	1	30294000007	1
22	Ambient Temperature Sensor	'3900012123	1	'3900012123	1
23	Temperature Sensor	'390001921G	1	'390001921G	1
24	Hook	'02112446	4	'02112466	4
25	Right Side Plate Sub-Assy	'01315200077	1	'01315200077	1
26	Choke Plug of Water Pipe	'76712454	1	'76712454	1
27	Right Support of Evaporator	'01078625	1	'01078625	1
28	Centrifugal fan assy	'15405200032	1	'15405200031	1
29	Front Volute Casing	'22202030	2	'22202030	2
30	Return air frame sub-assy	'01498641	1	'01498641	1
31	DC Brushless Motor	'15704100001	1	'15704100001	1
32	Motor Support Sub-Assy	'01709056	2	'01709056	2

◆ Model: GFH24K3FI/GFH30K3FI exploded view and spare parts list

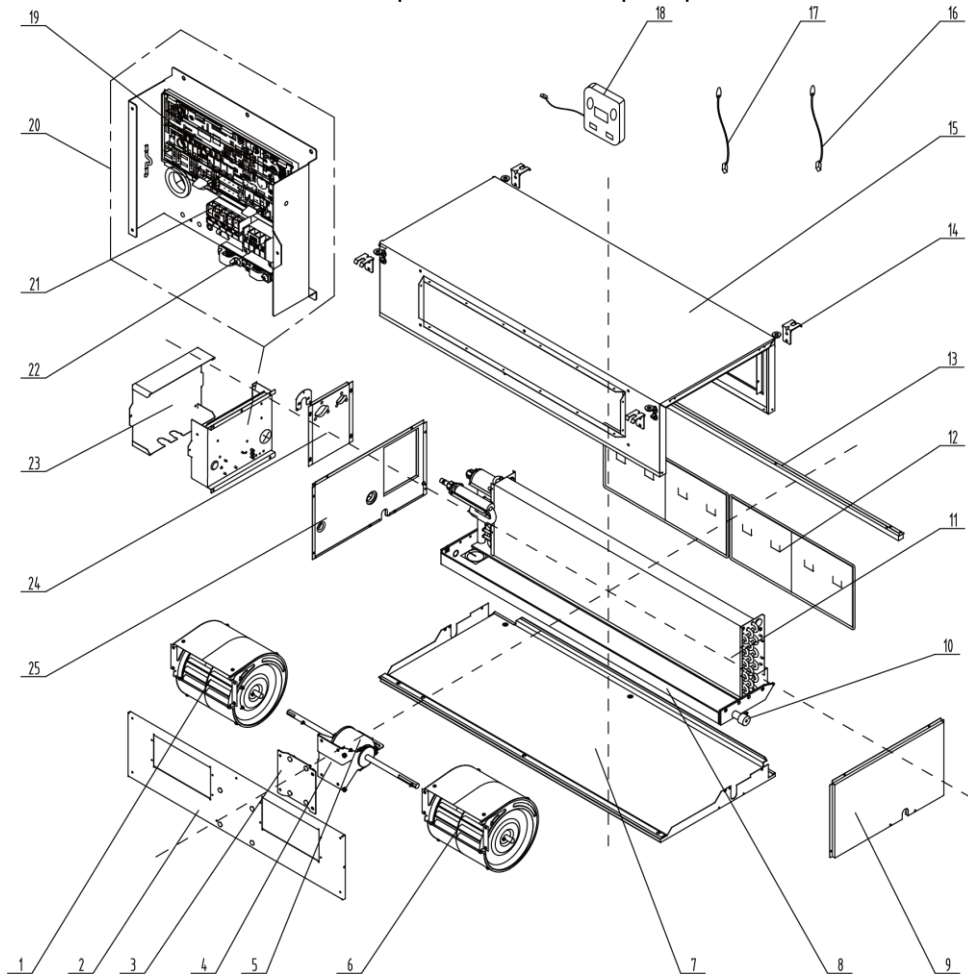

NO.	Name of Part	GFH24K3FI		GFH30K3FI	
		Product Code	CF060N0450	Product Code	CF060N0460
		Part Code	Quantity	Part Code	Quantity
1	Blower	'15012454	1	'15012454	1
2	Blower Mounting Plate Sub-Assy	` 01325200039	1	'01325200039	1
3	Supporter	'01805200164	1	'01805200164	1
4	Supporter	` 01804100140	1	'01804100140	1
5	Brushless DC Motor	'15705200006	1	'15705200006	1
6	Blower	'15012458	1	'15012458	1
7	Lower Cover Plate Sub-Assy	'01265304	1	'01265304	1
8	Drain Pan Assy	'01285317	1	'01285317	1
9	Left Side Plate Assy	'01314155	1	'01314155	1
10	Choke Plug of Drain Pipe	'76712455	1	'76712455	1
11	Evaporator Assy	'01025200050	1	'01025200050	1
12	Filter Sub-Assy	'11125303	2	'11125303	2
13	Guiding Slot of Filter	'02285301	1	'02285301	1
14	Hook	'02112446	4	'02112446	4
15	Top Cover Board Assy	'01265226	1	'01265226	1
16	Temperature Sensor	` 3900012128	1	'3900012128	1
17	Ambient Temperature Sensor	'3900012123	1	'3900012123	1
18	Display Board	'30294000007	1	'30294000007	1
19	Main Board	'30224000030	1	'30224000030	1
20	Electric Box Assy	'01395200212	1	'01395200212	1
21	Terminal Board	'42010194	1	'42010194	1
22	Terminal Board	` 4201025301	1	` 4201025301	1
23	Electric Box Cover	'01425200043	1	'01425200043	1
24	Cover Plate Sub-Assy	'0126520009801	1	'0126520009801	1
25	Right Side Plate Sub-Assy	'01315200057	1	'01315200057	1

◆ Model: GFH36K3FI/GFH42K3FI exploded view and spare parts list

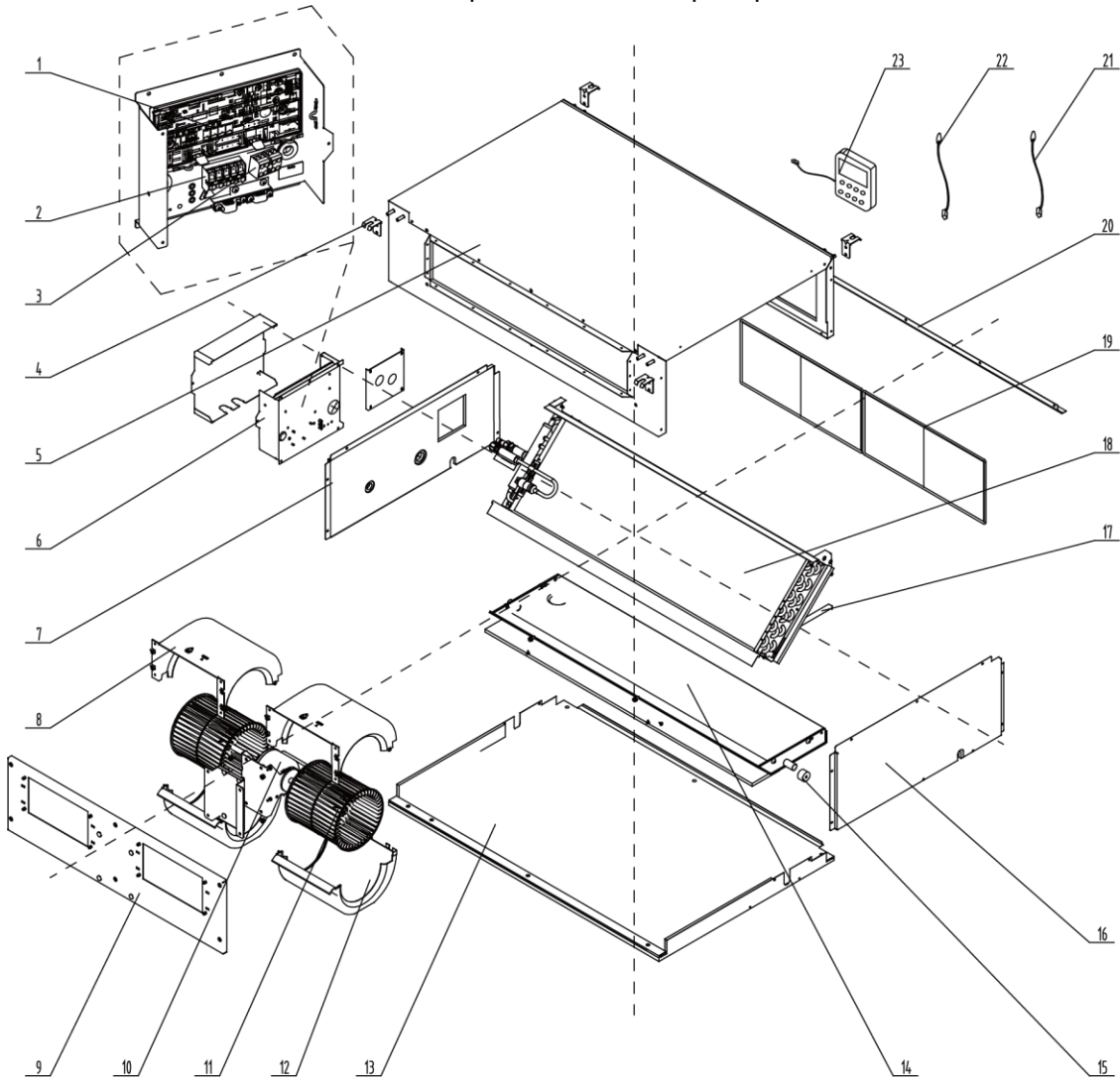

NO.	Name of Part	GFH36K3FI		GFH42K3FI	
		Product Code	CF060N0470	Product Code	CF060N0480
		Part Code	Quantity	Part Code	Quantity
1	Main Board	'30224000030	1	'30224000030	1
2	Terminal Board	'42010194	1	'42010194	1
3	Terminal Board	'4201025301	1	'4201025301	1
4	Hook	'02112466	4	'02112466	4
5	Top Cover Board Assy	'01265200086	1	'01265200086	1
6	Electric Box Assy	'01395200212	1	'01395200212	1
7	Right Side Plate Sub-Assy	'01315200061	1	'01315200061	1
8	Volute Casing (Upper)	'26904100051	2	'26904100051	2
9	Blower Mounting Plate Sub-Assy	'01325200044	1	'01325200044	1
10	Brushless DC Motor	'15709400006	1	'15709400006	1
11	Centrifugal Fan Blade	'10424100001	2	'10424100001	2
12	Volute Casing (Lower)	'26904100052	2	'26904100052	2
13	Lower Cover Plate Sub-Assy	'15265301	1	'15265301	1
14	Drain Pan Assy	'01285323	1	'01285323	1
15	Drain Pipe Plug	'76712455	1	'76712455	1
16	Left Side Plate Assy	'01315306	1	'01315306	1
17	Support Plate of Evaporator	'018953022	1	'018953022	1
18	Evaporator Assy	'01025200052	1	'01025200052	1
19	Filter Sub-Assy	'111253031	2	'111253031	2
20	Side Plate of Air Inlet	'01375301	1	'01375301	1
21	Temperature Sensor	'390001921G	1	'390001921G	1
22	Ambient Temperature Sensor	'3900012123	1	'3900012123	1
23	Display Board	'30294000007	1	'30294000007	1

◆ Model: GFH48K3FI exploded view and spare parts list

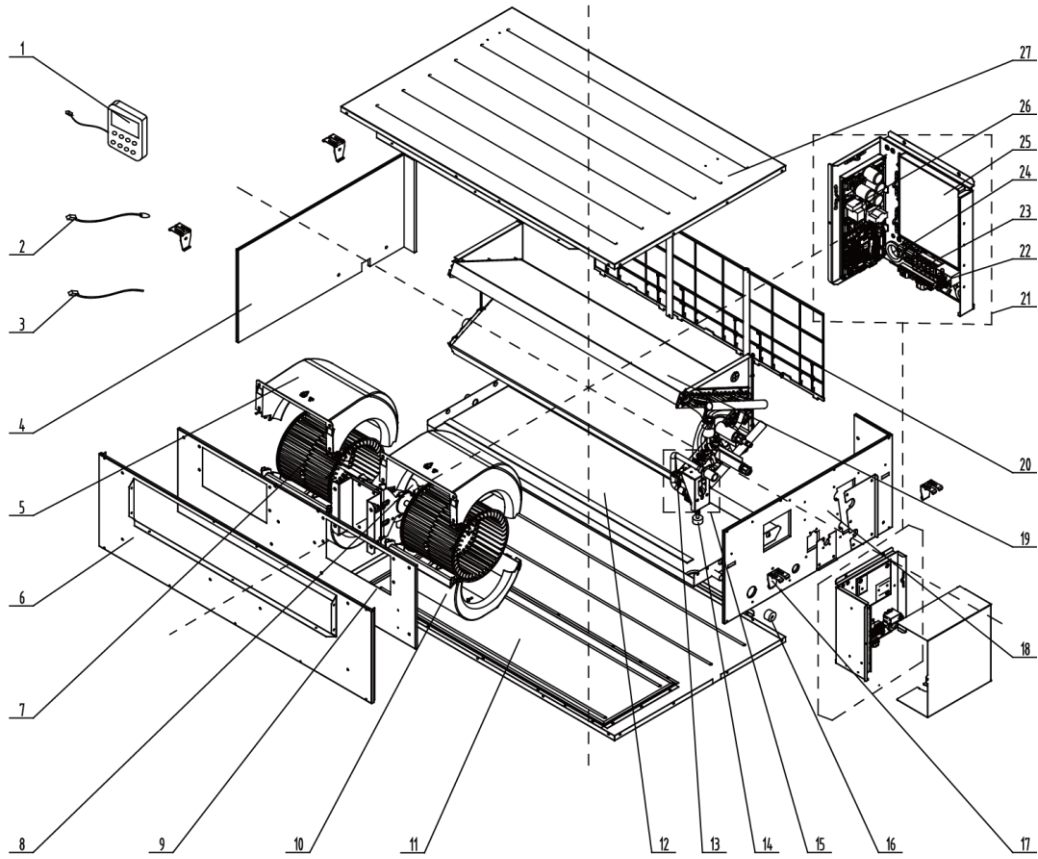

NO.	Name of Part	GFH36K3FI	
		Product Code	CF060N0490
		Part Code	Quantity
1	Display Board	'30294000007	1
2	Temperature Sensor	` 3900012128	1
3	Tube Sensor	` 3900012123	1
4	Left Side Plate Sub-Assy	'01315200064	1
5	Propeller Housing(Upper)	'26905200010	2
6	Front Side Plate	'01315200080	1
7	Centrifugal Fan	'10425200002	2
8	Brushless DC Motor	'15709400008	1
9	Blower Mounting Plate Sub-Assy	'01325200057	1
10	Propeller Housing(Lower)	'26905200011	2
11	Bottom Cover Board Assy	'01265200045	1
12	Drain Pan Assy	'01285200025	1
13	Pump Drainpipe	0	0
14	Water Level Switch	0	0
15	Water Pump Assy	0	0
16	Choke Plug of Drain Pipe	'76712455	2
17	Hook	'02205209	4
18	Right Side Plate Sub-Assy	' 0131520007801	1
19	Evaporator Assy	'01025200055	1
20	Filter Sub-Assy	'11122059	3
21	Electric Box Assy	'01395200259	1
22	Cold Plasma Device Sub-Assy	0	0
23	Terminal Board	'42010194	1
24	Terminal Board	'4201025301	1
25	Main Board	'30224000039	1
26	Main Board	'30221000011	1
27	Top Cover Plate Assy	'01265200081	1

5.2.2 Cassette Type

◆ Model: GKH12K3FI/GKH18K3FI exploded view and spare parts list.

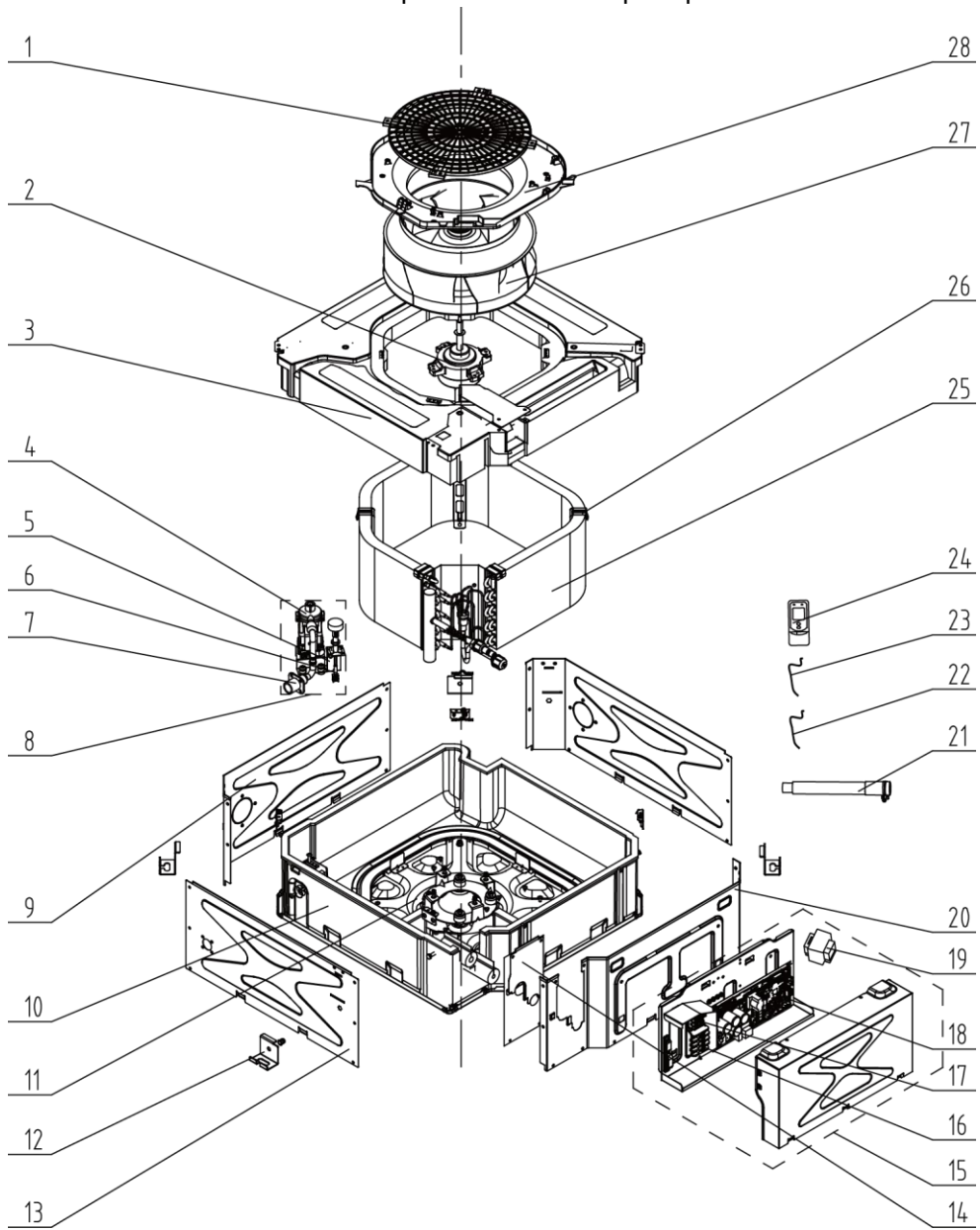

NO.	Name of Part	GKH18K3FI		GKH12K3FI	
		Product Code	ET010N0680	Product Code	ET010N0670
		Part Code	Quantity	Part Code	Quantity
1	Rear Grill	'26909400007	1	'26909400007	1
2	Brushless DC Motor	'15709400004	1	'15709400004	1
3	Water Tray Assy	'01289400004	1	'01289400004	1
4	Water Pump	'43138000024	1	'43138000024	1
5	Supporter	'01809400005	1	'01809400005	1
6	Water Level Switch	` 450102013	1	` 450102013	1
7	Pump Drainpipe	'04269400001	1	'04269400001	1
8	Water Pump Assy	'15409400003	1	'15409400003	1
9	Right Side Plate Sub-Assy	01319400013	2	'01319400013	2
10	Bottom Foam Assy	'12509400004	1	'12509400004	1
11	Base Plate Assy	'02229400007	1	'02229400007	1
12	Body Installing Support	'01332705	4	'01332705	4
13	Left Side Plate Sub-Assy	'01319400012	1	'01319400012	1
14	Pressure Plate of Outlet Pipe	'01349400004	1	'01349400004	1
15	Electric Box Assy	'01399400076	1	'01399400076	1
16	Terminal Board	'42010274	1	'42010274	1
17	Terminal Board	'4201025301	1	'4201025301	1
18	Main Board	'30224000028	1	'30224000028	1
19	Transformer	'43118000015	1	'43118000015	1
20	Front Side Plate Sub-Assy	'01319400014	1	'01319400014	1
21	Drain Hose Sub-Assy	'05232050	1	'05232050	1
22	Room Sensor	'39000191	1	'39000191	1
23	Tube sensor	'3900012128	1	'3900012128	1
24	Remote Controller	'305100413W	1	'305100413W	1
25	Evaporator Assy	'01029400013	1	'01029400013	1
26	Supporter	'01809400007	3	'01809400007	3
27	Centrifugal Fan	'10429400001	1	'10429400001	1

◆ Model: GKH24K3FI/GKH30K3FI/GKH36K3FI/GKH42K3FI exploded view and spare parts list.

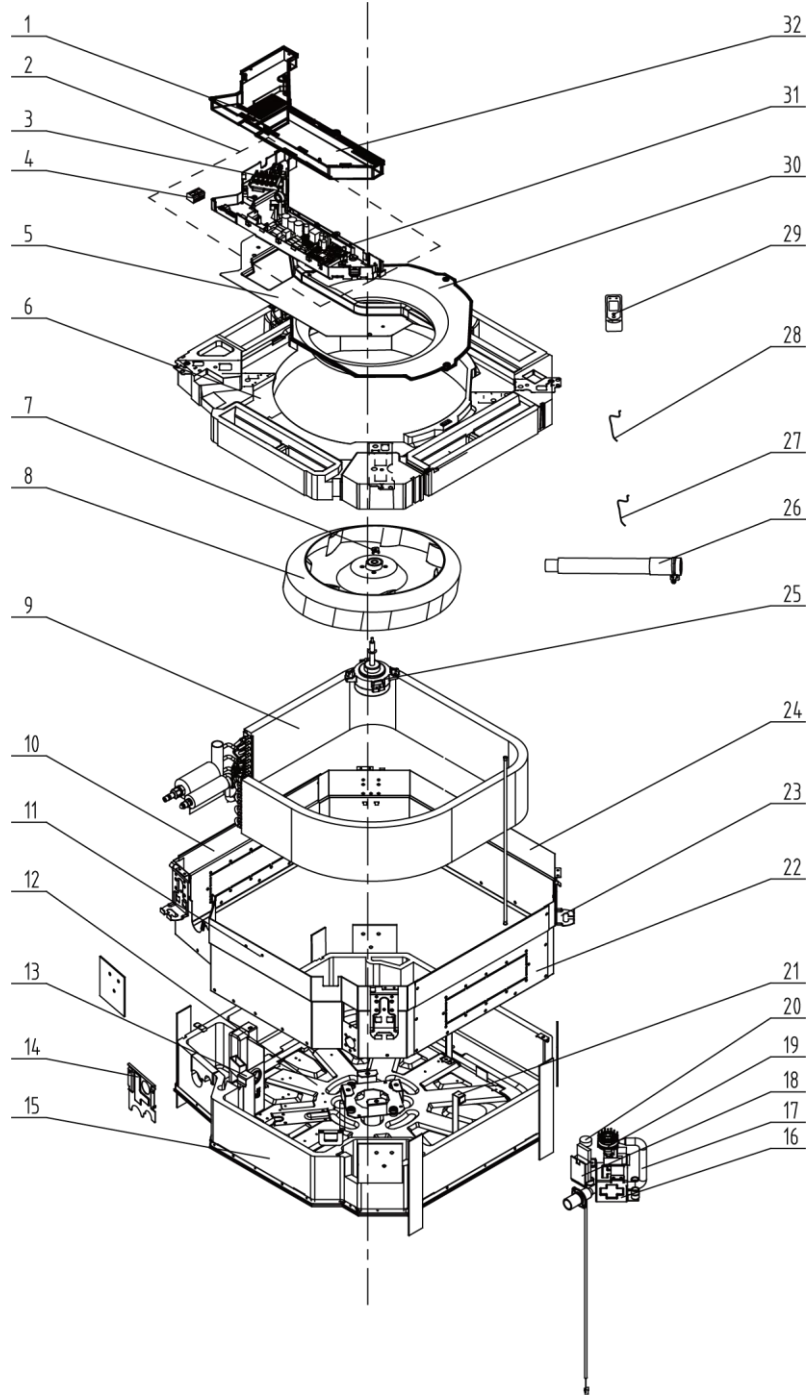

NO.	Name of Part	GKH24K3FI		GKH30K3FI	
		Product Code	ET010N0690	Product Code	ET010N0740
		Part Code	Quantity	Part Code	Quantity
1	Electric Box Cover Sub-Assy1	'20122054	1	'20122054	1
2	Electric Box Assy	'01399400057	1	'01399400057	1
3	Terminal Board	'4201025801	1	'4201025801	1
4	Terminal Board	'4201025301	1	'4201025301	1
5	Electric Base Plate	'01412721	1	'01412721	1
6	Water Tray Assy	'20182701	1	'20182701	1
7	Fan Fixer	'10312701	1	'10312701	1
8	Centrifugal Fan	'10312705	1	'10310101	1
9	Evaporator Assy	'01029400045	1	'01029400042	1
10	Left Side Plate Assy	'01302715	1	'01302711	1
11	Front Side Plate Assy	'01302718	1	'01302713	1
12	Base Plate Assy	'01222701	1	'01222701	1
13	Connected Board Assy of Evaporator	'01074042	1	'01072732	1
14	Tube Exit Plate Assy	'01382715	1	'01382715	1
15	Bottom Foam Assy	'52012722	1	'52012721	1
16	Pump Support	'01329416	1	'01332721	1
17	Pump Drainpipe	'05230026	1	'05230026	1
18	Pump Cover Board Assy	'01252713	1	'01252713	1
19	Water Pump	'43130324	1	'43130324	1
20	Water Level Switch	'45018012	1	'45018012	1
21	Evaporator Support Assy	'01072703	2	'01072707	2
22	Right Side Plate Assy	'01302716	1	'01302712	1
23	Body Installing Plate	'01332701	4	'01332701	1
24	Rear Side Plate Assy	'01302714	1	'01302709	1
25	Brushless DC Motor	'15709400004	1	'15709400003	1
26	Drain Hose Sub-Assy	'05232702	1	'05232702	1
27	Room Sensor	'390001912	1	'390001912	1
28	Temperature Sensor	'390001921G	1	'390001921G	1
29	Remote Controller	'305100413W	1	'305100413W	1
30	Diversion Circle	'10372701	1	'10372722	1
31	Main Board	'30224000028	1	'30224000028	1
32	Electric Box Cover Sub-Assy2	'20122055	1	'20122055	1

NO.	Name of Part	GKH36K3FI		GKH42K3FI	
		Product Code	ET010N0700	Product Code	ET010N0710
		Part Code	Quantity	Part Code	Quantity
1	Electric Box Cover Sub-Assy1	'20122054	1	'20122054	1
2	Electric Box Assy	'01399400057	1	'01399400057	1
3	Terminal Board	'4201025301	1	'4201025301	1
4	Terminal Board	'4201025301	1	'4201025301	1
5	Electric Base Plate	'01412721	1	'01412721	1
6	Water Tray Assy	'20182701	1	'20182701	1
7	Fan Fixer	'10312701	1	'10312701	1
8	Centrifugal Fan	'10310101	1	'10310101	1
9	Evaporator Assy	'01029400042	1	'01029400042	1
10	Left Side Plate Assy	'01302711	1	'01302711	1
11	Front Side Plate Assy	'01302713	1	'01302713	1
12	Base Plate Assy	'01222701	1	'01222701	1
13	Connected Board Assy of Evaporator	'01072732	1	'01072732	1
14	Tube Exit Plate Assy	'01382715	1	'01382715	1
15	Bottom Foam Assy	'52012721	1	'52012721	1
16	Pump Support	'01332721	1	'01332721	1
17	Pump Drainpipe	'05230026	1	'05230026	1
18	Pump Cover Board Assy	'01252713	1	'01252713	1
19	Water Pump	'43130324	1	'43130324	1
20	Water Level Switch	'45018012	1	'45018012	1
21	Evaporator Support Assy	'01072707	2	'01072707	2
22	Right Side Plate Assy	'01302712	1	'01302712	1
23	Body Installing Plate	'01332701	1	'01332701	1
24	Rear Side Plate Assy	'01302709	1	'01302709	1
25	Brushless DC Motor	'15709400003	1	'15709400003	1
26	Drain Hose Sub-Assy	'05232702	1	'05232702	1
27	Room Sensor	'390001912	1	'390001912	1
28	Temperature Sensor	'390001921G	1	'390001921G	1
29	Remote Controller	'305100413W	1	'305100413W	1
30	Diversion Circle	'10372722	1	'10372722	1
31	Main Board	'30224000028	1	'30224000028	1
32	Electric Box Cover Sub-Assy2	'20122055	1	'20122055	1

◆ Model: GKH48K3FI/GKH60K3FI exploded view and spare parts list.

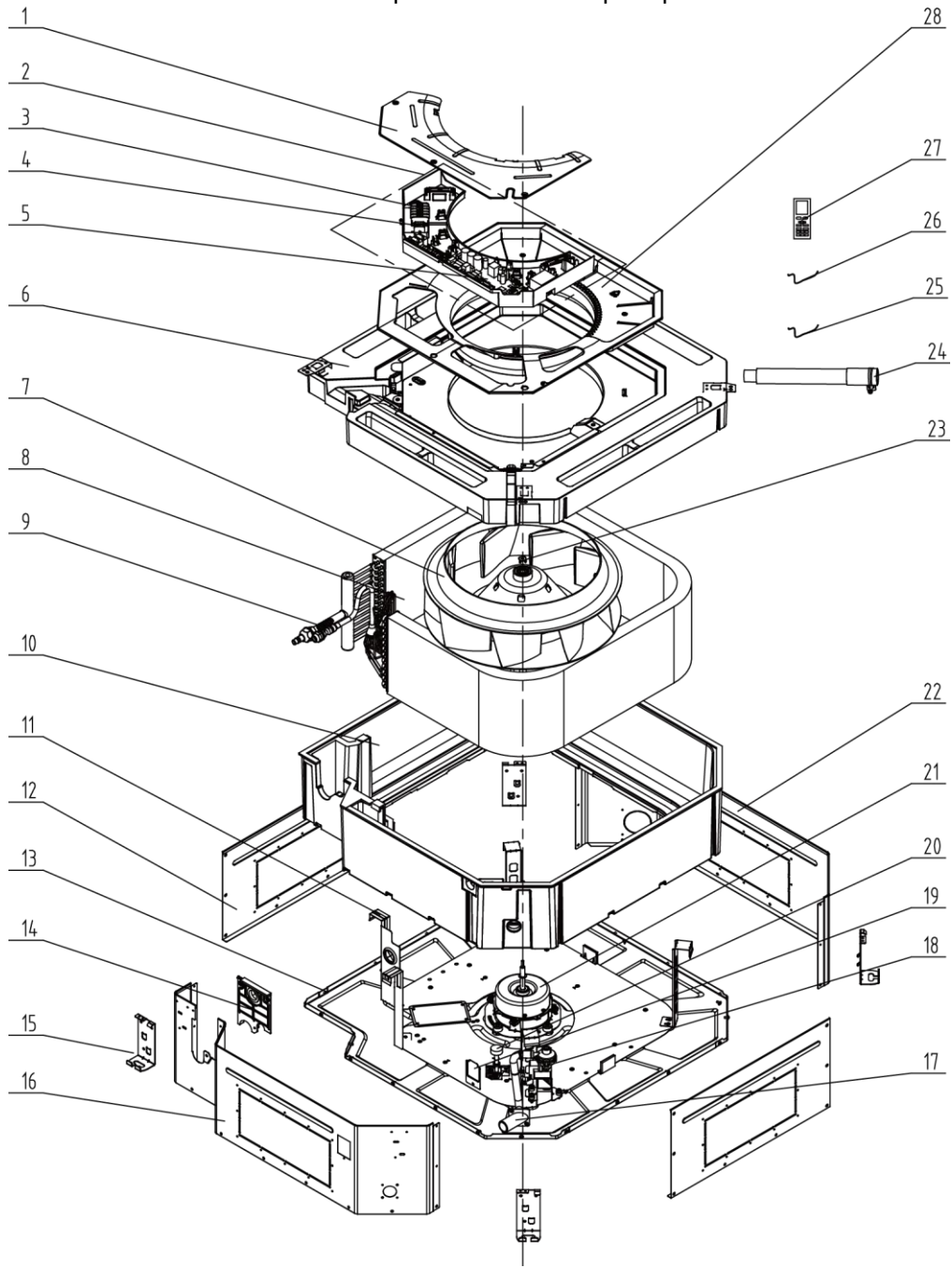

NO.	Name of Part	GKH48K3FI	
		Product Code	ET010N0720
		Part Code	Quantity
1	Electric Box Cover Plate	'01429423P	1
2	Electric Box Assy	'01399400074	1
3	Terminal Board	'4201025801	1
4	Terminal Board	'4201025301	1
5	Main Board	'30224000028	1
6	Drain Pan Assy	'01289400002	1
7	Centrifugal Fan	'10429401	1
8	Evaporator Assy	'01029400054	1
9	Filter	'07212403	1
10	Foam Assy	'12509400001	1
11	Connection Sheet Sub-Assy	'01349400002	1
12	Left and Right Side Board	'01319448	2
13	Seat Board Sub-Assy	'02229400001	1
14	Tube Exit Plate Sub-Assy	'02229400002	1
15	Mounting Board	' 01329420	1
16	Front Side Plate	'01319447	1
17	Drain Hose	'05339401	1
18	Water Pump Assy	'15409400001	1
19	Pump Cover Board Assy	'01252713	1
20	Liquid Level Switch Sub-Assy	'45018000001	1
21	Brushless DC Motor	'15709400002	1
22	Rear Side Plate	'01319446	1
23	Fan Fixer	'10312701	1
24	Drain Hose Sub-Assy	'05232702	1
25	Room Sensor	'39000191	1
26	Temperature Sensor	'390001921G	1
27	Remote Controller	'305100413W	1
28	Diversion Circle	'10479401	1

5.2.3 Floor Ceiling Type

◆ Model: GTH09K3FI/GTH12K3FI/GTH18K3FI/GTH24K3FI exploded view and spare parts list.

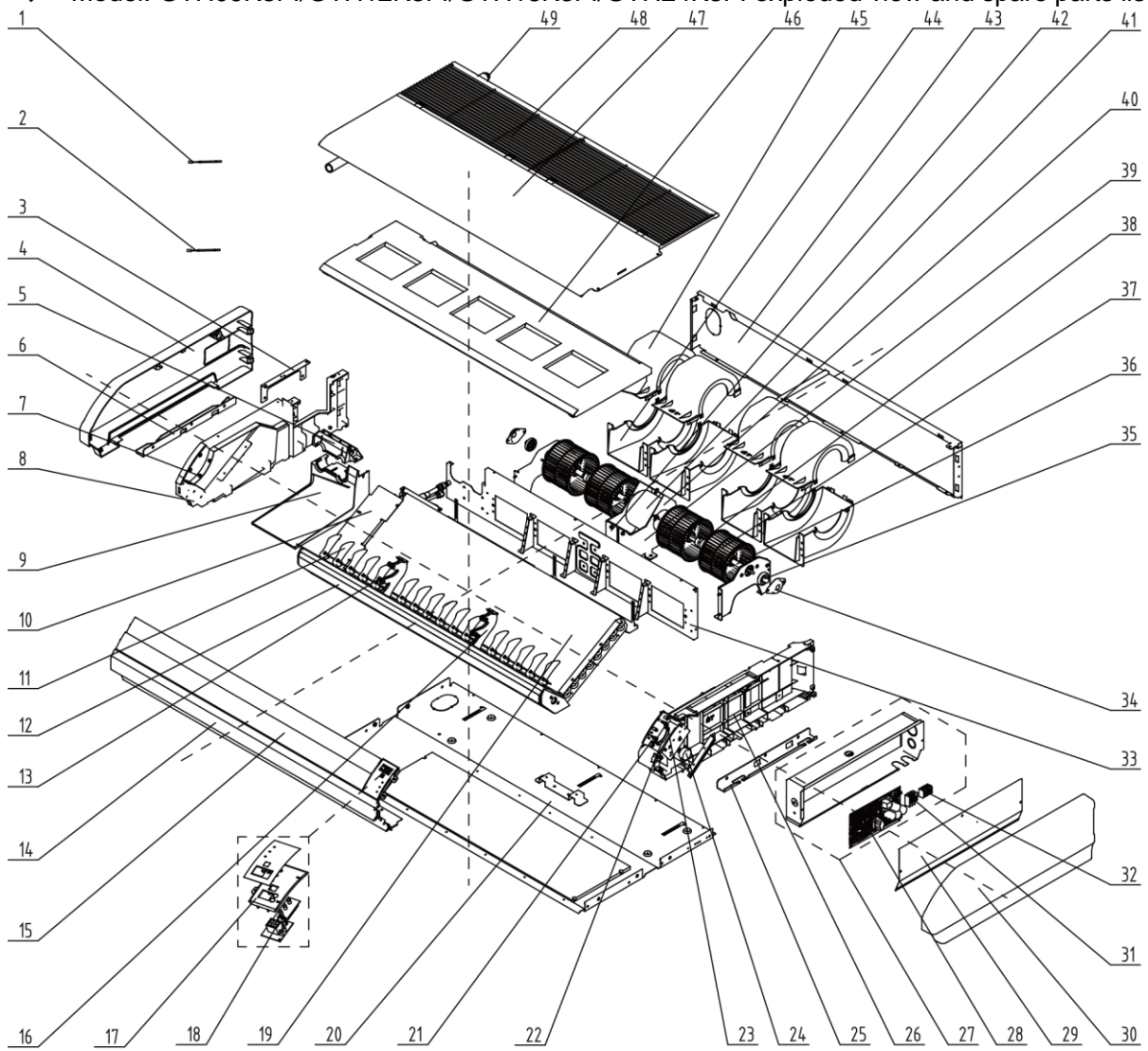

NO.	Name of Part	GTH09K3FI		GTH12K3FI	
		Product Code	ED020N0650	Product Code	ED020N0660
		Part Code	Quantity	Part Code	Quantity
1	Tube Sensor	'390001923	1	'390001923	1
2	Room Sensor	'39000191	1	'39000191	1
3	Connection Board	'02229406	1	'02229406	1
4	Right Cover Plate	'26909444	1	'26909444	1
5	Plate Board of Water Releasing Flume	'26909442	1	'26909442	1
6	Installation Supporting Frame	'01809402	1	'01809402	1
7	Axile Bush	'10542704	2	'10542704	2
8	Right Side Plate Sub-Assy	'01319429	1	'01319429	1
9	Water Releasing Flume	` 26909450	1	` 26909450	1
10	Connected Board (Evaporator)	` 01344115	1	'01349421	1
11	Air Louver	'10619404	16	'10619404	16
12	Guide Louver Support	'0180941601	1	'0180941601	1
13	Rotating Shaft	'26909430	4	'26909430	4
14	Front Connection Board	'01349414P	1	'01349414P	1
15	Guide Louver	'10619403	2	'10619403	2
16	Supporter	'26909449	2	'26909449	2
17	Fixed Mount	'26909426R	1	'26909426R	1
18	Display Board	'30294000009	1	'30294000009	1
19	Evaporator Assy	' 1029400060	1	'01029473	1
20	Rear Side Plate Assy	'01319400008	1	'01319400008	1
21	Rotating Shaft	'26909413	1	'26909413	1
22	Connecting Rod	'26909411	1	'26909411	1
23	Rotating Shaft	'26909412	1	'26909412	1
24	Stepping Motor	'1521240206	1	'1521240206	1
25	Installation Supporting Frame	'01809401	1	'01809401	1
26	Left Side Plate Sub-Assy	'01319428	1	'01319428	1
27	Electric Box Assy	'01399400071	1	'01399400071	1
28	Main Board	'30224000029	1	'30224000029	1
29	Electric Box Cover	'01429420	1	'01429420	1
30	Left Cover Plate	'26909443	1	'26909443	1
31	Terminal Board	'42010178	1	'42010178	1
32	Terminal Board	'4201025301	1	'4201025301	1
33	Mid-clapboard Sub-Assy	'01249416	1	'01249416	1
34	Support of Motor Bearing	'01792408	2	'01792408	2
35	O-Gasket of Bearing	'76512404	2	'76512404	2
36	Rotary Axis Sub-Assy	'73018000037	2	'73018000037	2
37	Centrifugal Fan	'10425200	4	'10425200	4
38	Joint Slack	'73018731	2	'73018731	2
39	Support	'01809400024	1	'01809400024	1
40	Clamping Band Assy	' 0818000033	1	' 0818000033	1
41	DC brushless Motor	'15704100001	1	'15704100001	1
42	Support	'01809400023	1	'01809400023	1
43	Rear Connection Board	'01349422	1	'01349422	1
44	Front Volute Casing	'26905205	4	'26905205	4
45	Rear Volute Casing	'26905206	4	'26905206	4
46	Drain Pan Assy	'01289404	1	'01289404	1
47	Top Cover Board Sub-Assy	'01269409	1	'01269409	1
48	Front Grill Sub-Assy	'01579403	2	'01579403	2
49	Drain Pipe Sub-Assy	'05235434	1	'05235434	1

NO.	Name of Part	GTH18K3FI		GTH24K3FI	
		Product Code	ED020N0670	Product Code	ED020N0680
		Part Code	Quantity	Part Code	Quantity
1	Tube Sensor	'390001923	1	'390001923	1
2	Room Sensor	'39000191	1	'39000191	1
3	Connection Board	'02229406	1	'02229406	1
4	Right Cover Plate	'26909444	1	'26909444	1
5	Plate Board of Water Releasing Flume	'26909442	1	'26909442	1
6	Installation Supporting Frame	'01809402	1	'01809402	1
7	Axile Bush	'10542704	2	'10542704	2
8	Right Side Plate Sub-Assy	'01319429	1	'01319429	1
9	Water Releasing Flume	'26909450	1	'26909450	1
10	Connected Board (Evaporator)	'01349421	1	'01349421	1
11	Air Louver	'10619404	16	'10619404	16
12	Guide Louver Support	'0180941601	1	'0180941601	1
13	Rotating Shaft	'26909430	4	'26909430	4
14	Front Connection Board	'01349414P	1	'01349414P	1
15	Guide Louver	'10619403	2	'10619403	2
16	Supporter	'26909449	2	'26909449	2
17	Fixed Mount	'26909426R	1	'26909426R	1
18	Display Board	'30294000009	1	'30294000009	1
19	Evaporator Assy	'01029468	1	'01029400046	1
20	Rear Side Plate Assy	'01319400008	1	'01319400008	1
21	Rotating Shaft	'26909413	1	'26909413	1
22	Connecting Rod	'26909411	1	'26909411	1
23	Rotating Shaft	'26909412	1	'26909412	1
24	Stepping Motor	'1521240206	1	'1521240206	1
25	Installation Supporting Frame	'01809401	1	'01809401	1
26	Left Side Plate Sub-Assy	'01319428	1	'01319428	1
27	Electric Box Assy	'01399400071	1	'01399400071	1
28	Main Board	'30224000029	1	'30224000029	1
29	Electric Box Cover	'01429420	1	'01429420	1
30	Left Cover Plate	'26909443	1	'26909443	1
31	Terminal Board	'42010178	1	'42010178	1
32	Terminal Board	'4201025301	1	'4201025301	1
33	Mid-clapboard Sub-Assy	'01249416	1	'01249416	1
34	Support of Motor Bearing	'01792408	2	'01792408	2
35	O-Gasket of Bearing	'76512404	2	'76512404	2
36	Rotary Axis Sub-Assy	'73018000037	2	'73018000037	2
37	Centrifugal Fan	'10425200	4	'10425200	4
38	Joint Slack	'73018731	2	'73018731	2
39	Support	'01809400024	1	'01809400024	1
40	Clamping Band Assy	'0818000033	1	'70818000033	1
41	DC brushless Motor	'15704100001	1	'15704100001	1
42	Support	'01809400023	1	'01809400023	1
43	Rear Connection Board	'01349422	1	'01349422	1
44	Front Volute Casing	'26905205	4	'26905205	4
45	Rear Volute Casing	'26905206	4	'26905206	4
46	Drain Pan Assy	'01289404	1	'01289404	1
47	Top Cover Board Sub-Assy	'01269409	1	'01269409	1
48	Front Grill Sub-Assy	'01579403	2	'01579403	2
49	Drain Pipe Sub-Assy	'05235434	1	'05235434	1

◆ Model: GTH30K3FI/GTH36K3FI/GTH42K3FI exploded view and spare parts list.

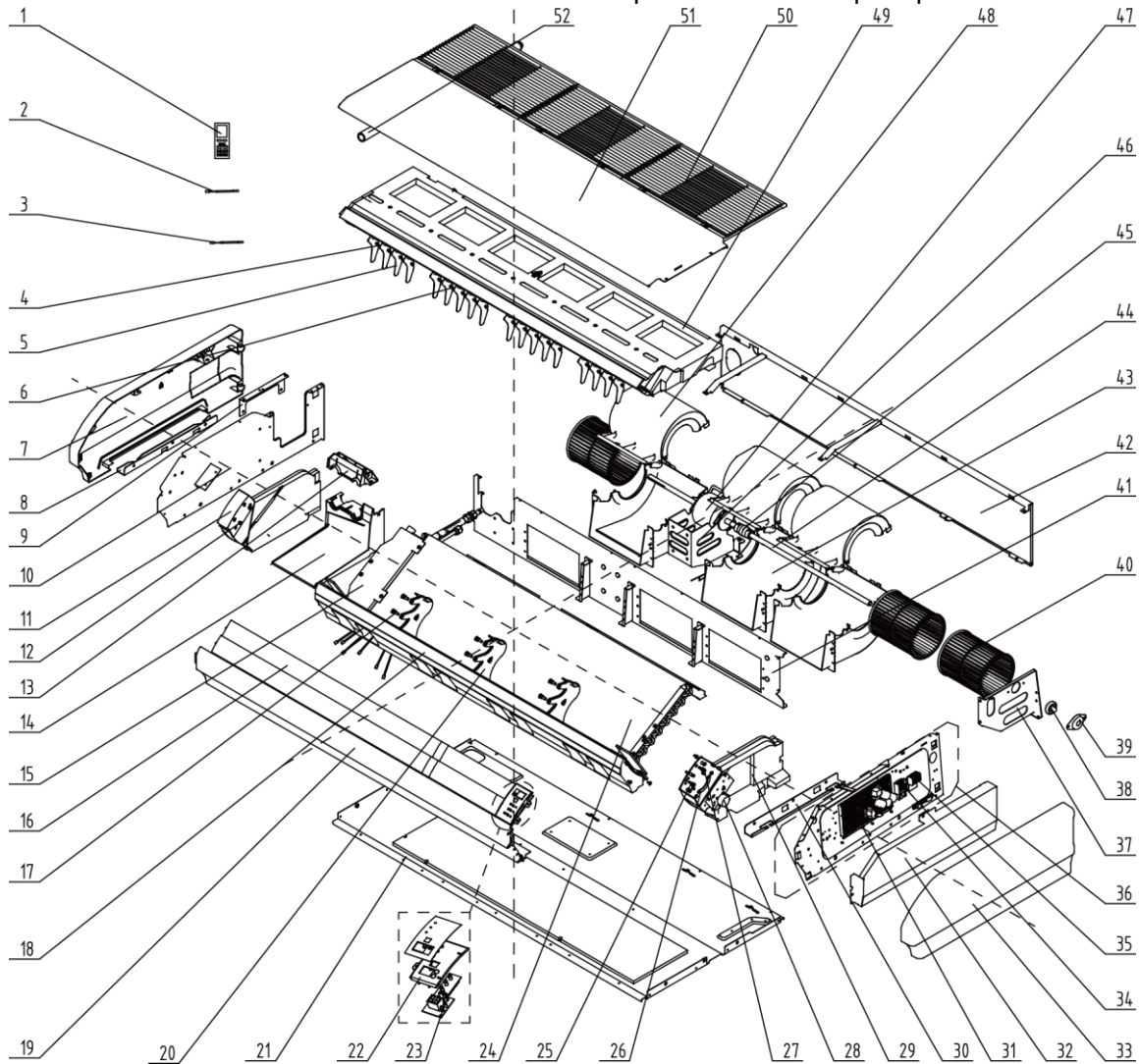

NO.	Name of Part	GTH30K3FI		GTH36K3FI	
		Product Code	ED020N0690	Product Code	ED020N0700
		Part Code	Quantity	Part Code	Quantity
1	Drain Pipe Sub-Assy	'05235434	1	'05235434	1
2	Tube Sensor	'390001923	1	'390001923	1
3	Room Sensor	'39000191	1	'39000191	1
4	Swing Lever	'10582008	2	'10582008	2
5	Air Louver	'26909418	18	'26909418	18
6	Swing Lever	'10582009	2	'10582009	2
7	Right Cover Plate	'26909422	1	'26909422	1
8	Installation Supporting Frame	'01809402	1	'01809402	1
9	Connection Board	'02229406	1	'02229406	1
10	Right Side Plate Sub-Assy	'01319408	1	'01319408	1
11	Right Foam Assy	'12509425	1	'12509425	1
12	Axile Bush	'10542704	2	'10542704	2
13	Plate Board of Water Releasing Flume	'26909442	1	'26909442	1
14	Water Releasing Flume	'26909441	1	'26909441	1
15	Connection Board	'01349413	1	'01349413	1

16	Guide Louver	'26909432	2	'26909432	2
17	Rotating Shaft	'26909430	6	'26909430	6
18	Front Connection Board Foam Assy	'12509424	1	'12509424	1
19	Front Connection Board	'01349408P	1	'01349408P	1
20	Supporter	'26909409	3	'26909409	3
21	Rear Side Plate Assy	01319400005	1	'01319400005	1
22	Fixed Mount	'26909426R	1	'26909426R	1
23	Display Board	'30294000009	1	'30294000009	1
24	Evaporator Assy	01029400041	1	'01029400050	1
25	Rotating Shaft	'26909413	1	'26909413	1
26	Connecting Rod	'26909411	1	'26909411	1
27	Rotating Shaft	'26909412	1	'26909412	1
28	Stepping Motor	'1521240206	1	'1521240206	1
29	Left Foam Assy	'12509408	1	'12509408	1
30	Installation Supporting Frame	'01809401	1	'01809401	1
31	Main Board	'30224000029	1	'30224000029	1
32	Electric Box Cover	'01429410P	1	'01429410P	1
33	Left Cover Plate	'26909416	1	'26909416	1
34	Terminal Board	'42010178	1	'42010178	1
35	Terminal Board	'4201025301	1	'4201025301	1
36	Electric Box Assy	'01399400058	1	'01399400058	1
37	Bracket 1	'01809404	1	'01809404	1
38	O-Gasket of Bearing	'76512404	1	'76512404	1
39	Support of Motor Bearing	'01792408	1	'01792408	1
40	Centrifugal Fan Blade	'1041410101	3	'1041410101	3
41	Clapboard Sub-Assy	01249400002	1	01249400002	1
42	Rear Connection Board	'01349418	1	'01349418	1
43	Front Volute Casing	'26905208	3	'26905208	3
44	Joint Slack	'73018731	1	'73018731	1
45	Motor Support Sub-Assy	'01809400029	1	'01809400029	1
46	Brushless DC Motor	'15705200005	1	'15705200005	1
47	Motor Support Sub-Assy	0	0	0	0
48	Rotary Axis Sub-Assy	'73018052	1	'73018052	1
49	Rear Volute Casing	'26909419	3	'26909419	3
50	Drain Pan Assy	'01289405	1	'01289405	1
51	Front Grill	'01579402	3	'01579402	3
52	Top Cover Board Sub-Assy	'01269405	1	'01269405	1

NO.	Name of Part	GTH42K3FI	
		Product Code	ED020N0710
		Part Code	Quantity
1	Drain Pipe Sub-Assy	'05235434	1
2	Tube Sensor	'390001923	1
3	Room Sensor	'39000191	1
4	Swing Lever	'10582008	2
5	Air Louver	'26909418	18
6	Swing Lever	'10582009	2
7	Right Cover Plate	'26909422	1

8	Installation Supporting Frame	'01809402	1
9	Connection Board	'02229406	1
10	Right Side Plate Sub-Assy	'01319408	1
11	Right Foam Assy	'12509425	1
12	Axile Bush	'10542704	2
13	Plate Board of Water Releasing	'26909442	1
14	Water Releasing Flume	'26909441	1
15	Connection Board	'01349413	1
16	Guide Louver	'26909432	2
17	Rotating Shaft	'26909430	6
18	Front Connection Board Foam	'12509424	1
19	Front Connection Board	'01349408P	1
20	Supporter	'26909409	3
21	Rear Side Plate Assy	01319400005	1
22	Fixed Mount	'26909426R	1
23	Display Board	'30294000009	1
24	Evaporator Assy	'01029400050	1
25	Rotating Shaft	'26909413	1
26	Connecting Rod	'26909411	1
27	Rotating Shaft	'26909412	1
28	Stepping Motor	'1521240206	1
29	Left Foam Assy	'12509408	1
30	Installation Supporting Frame	'01809401	1
31	Main Board	'30224000029	1
32	Electric Box Cover	'01429410P	1
33	Left Cover Plate	'26909416	1
34	Terminal Board	'42010178	1
35	Terminal Board	'4201025301	1
36	Electric Box Assy	'01399400058	1
37	Bracket 1	'01809404	1
38	O-Gasket of Bearing	'76512404	1
39	Support of Motor Bearing	'01792408	1
40	Centrifugal Fan Blade	'1041410101	3
41	Clapboard Sub-Assy	01249400002	1
42	Rear Connection Board	'01349418	1
43	Front Volute Casing	'26905208	3
44	Joint Slack	'73018731	1
45	Motor Support Sub-Assy	'01809400029	1
46	Brushless DC Motor	'15705200005	1
47	Motor Support Sub-Assy	0	0
48	Rotary Axis Sub-Assy	'73018052	1
49	Rear Volute Casing	'26909419	3
50	Drain Pan Assy	'01289405	1
51	Front Grill	'01579402	3
52	Top Cover Board Sub-Assy	'01269405	1

◆ Model: GTH48K3FI/GTH60K3FI exploded view and spare parts list.

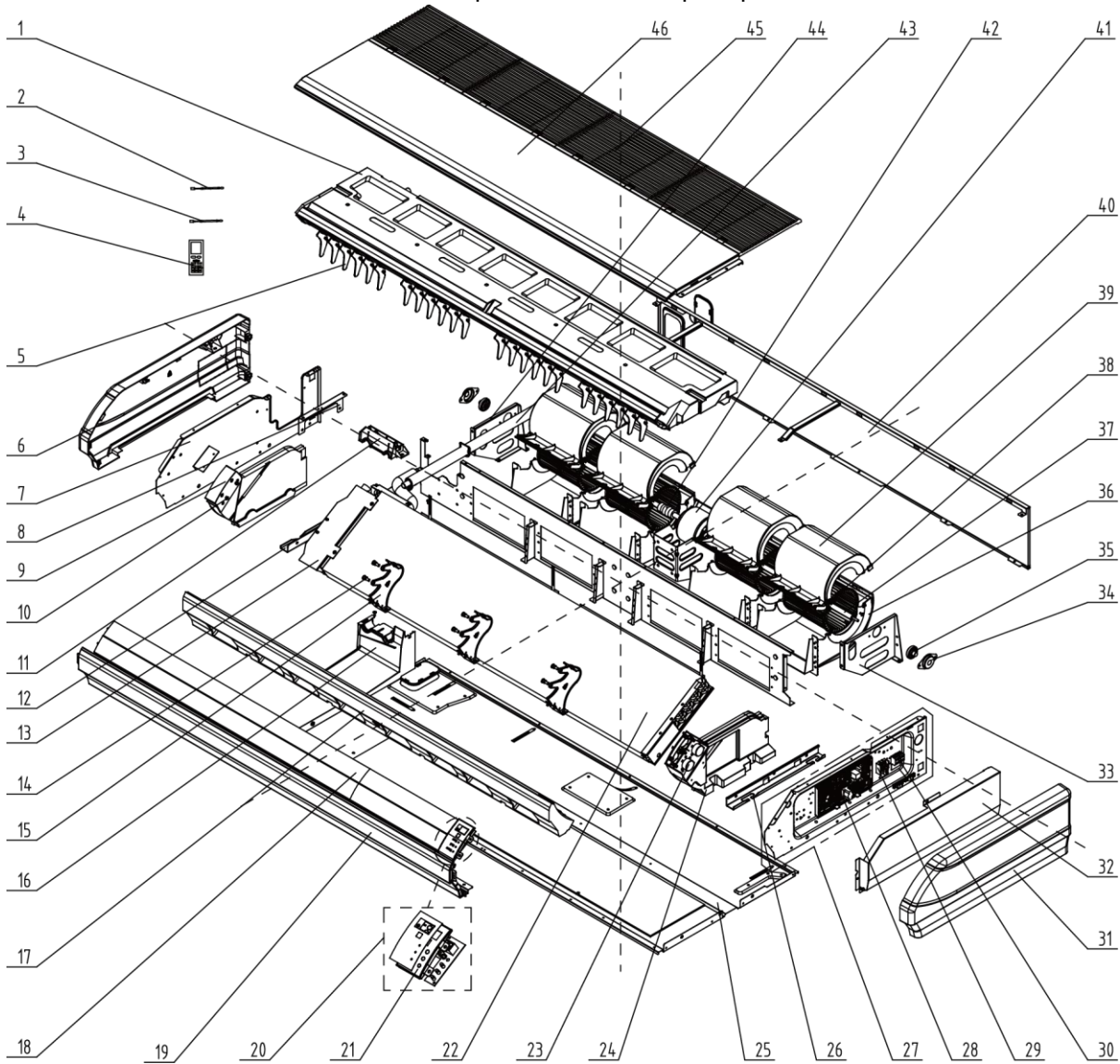

NO.	Name of Part	GTH48K3FI	
		Product Code	ED020N0720
		Part Code	Quantity
1	Water Tray Assy	'01289401	1
2	Tube Sensor	'3900020720G	1
3	Room Sensor	'39000191	1
4	Remote Controller	'305100413W	1
5	Air Louver	'26909418	24
6	Right Cover Plate	'26909422	1
7	Right Side Plate Sub-Assy	'01319408	1
8	Connection Board	'02229406	1
9	Right Foam Assy	'12509425	1
10	Axile Bush	'10542704	2
11	Plate Board of Water Releasing Flume	'26909442	1
12	Installation Supporting Frame	'01809402	1
13	connected Board (evaporator)	'01349412	1
14	Rotating Shaft	'26909430	6

15	Supporter	'26909409	3
16	Water Releasing Flume	'26909441	1
17	Front Connection Board Foam Assy	'12509434	1
18	Guide Louver	'10619405	2
19	Front Connection Board	'01349404P	1
20	Display Board	'30294000009	1
21	Fixed Mount	'26909426R	1
22	Evaporator Assy	'0102947101	1
23	Stepping Motor	'1521240206	2
24	Left Foam Assy	'12509437	1
25	Rear Side Plate Sub-Assy	'01319442	1
26	Installation Supporting Frame	'01809421	1
27	Electric Box Assy	'01399400073	1
28	Main Board	'30224000029	1
29	Terminal Board	'42010178	1
30	Terminal Board	'4201025301	1
31	Left Cover Plate	'26909416	1
32	Electric Box Cover	'01429410P	1
33	Bracket 1	'01809404	1
34	Support Of Motor Bearing	'01792408	2
35	O-Gasket of Bearing	'76512404	2
36	Front Volute Casing	'26905208	4
37	Rotary Axis Sub-Assy	'73018052	2
38	Centrifugal Fan	'1041410101	4
39	Rear Volute Casing	'26909419	4
40	Rear Connection Board	'01349419	1
41	Brushless DC Motor	'15709400005	1
42	Joint Slack	'73018731	2
43	Drainage Pipe Sub-Assy	'05235434	1
44	Supporter	'01809403	1
45	Front Grill Sub-Assy	'01579401	4
46	Top Cover Board Sub-Assy	'01269400002	1



JF00301816

GREE ELECTRIC APPLIANCES, INC. OF ZHUHAI

Add: West Jinji Rd, Qianshan, Zhuhai, Guangdong, China, 519070

Tel: (+86-756) 8522218 Fax: (+86-756) 8669426

E-mail: gree@gree.com.cn www.gree.com

For continuous improvement in the products, Gree reserves the right to modify the product specification and appearance in this manual without notice and without incurring any obligations.