

1

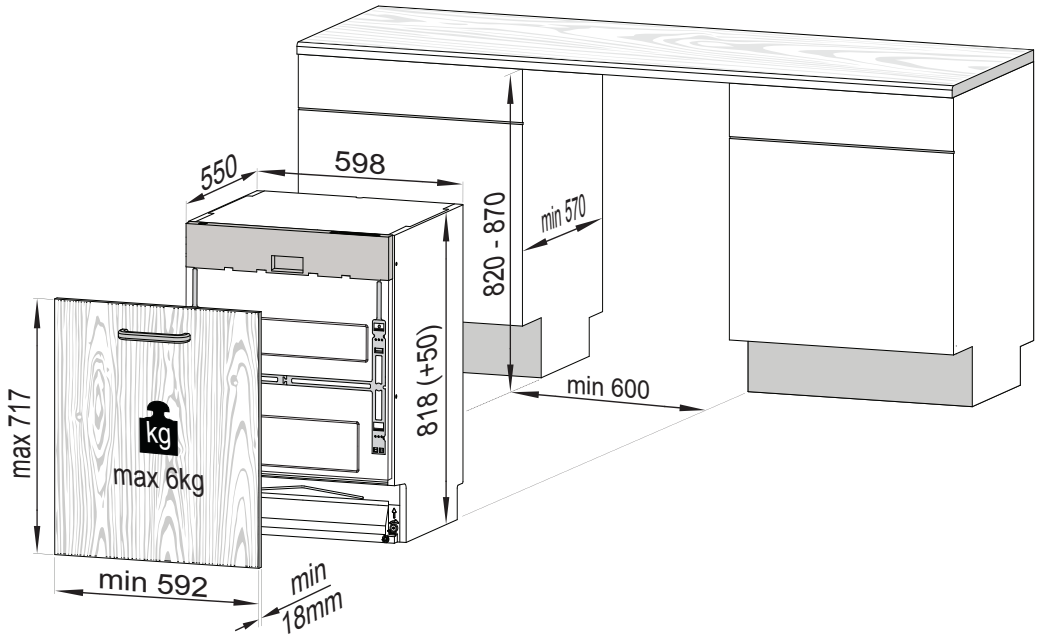

2

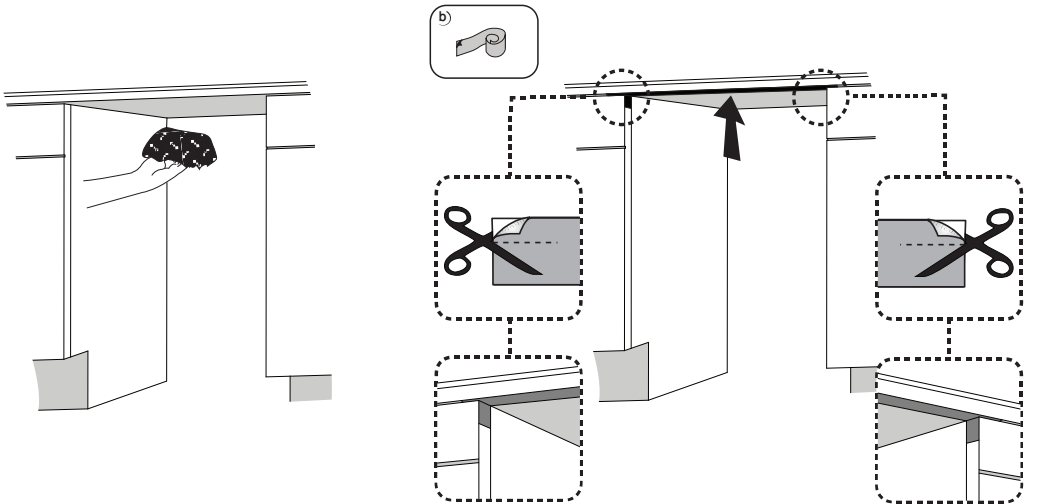



5

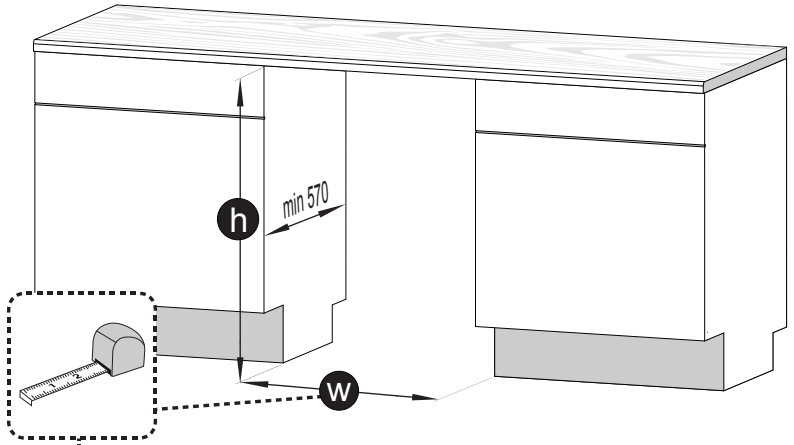

$w > 610$

6

$w = 600 - 610$

8

6

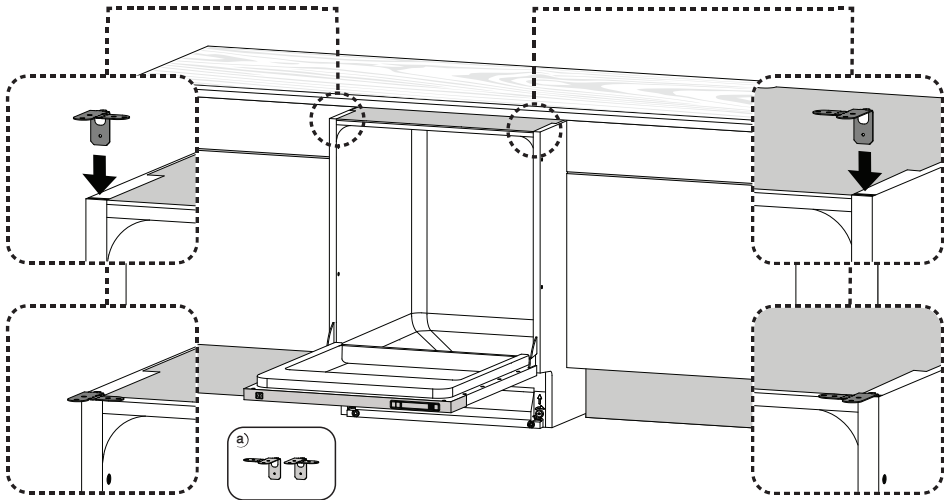

7

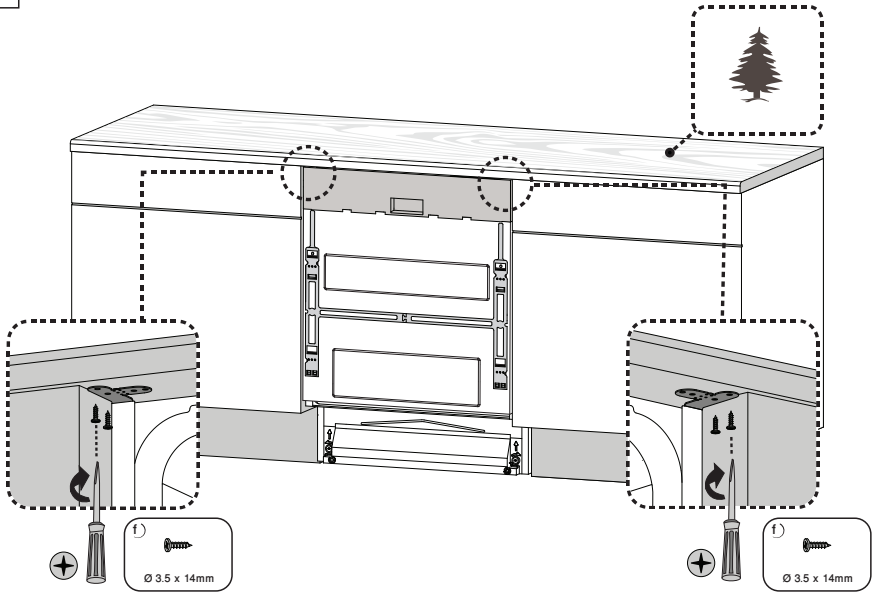

9

8

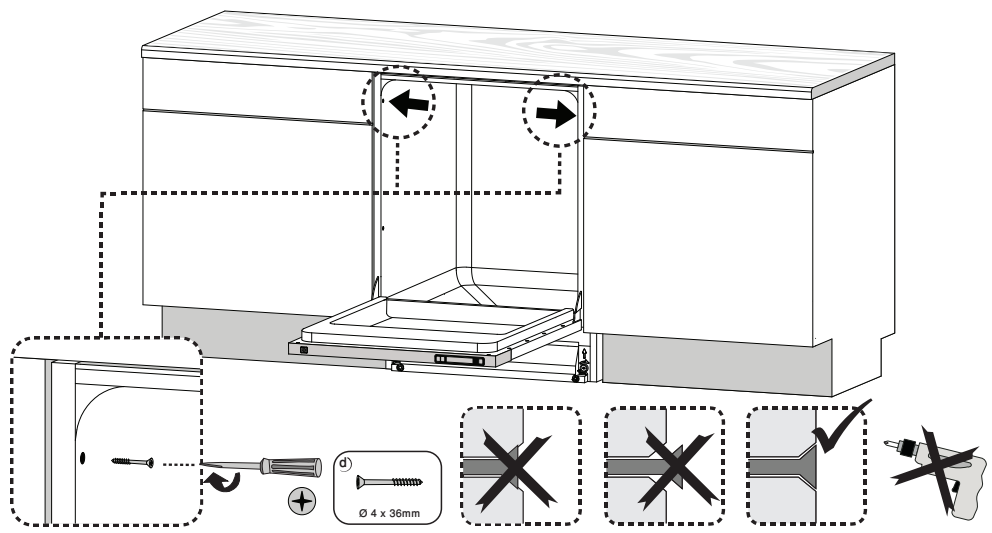

# 9

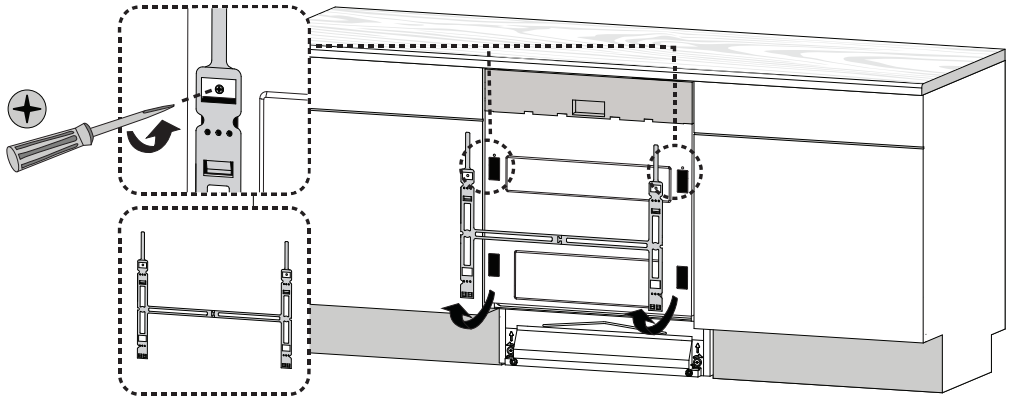

# 10

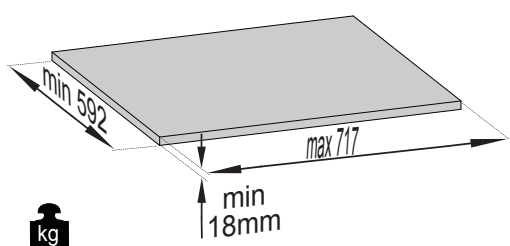

**kg**  
Max 6kg

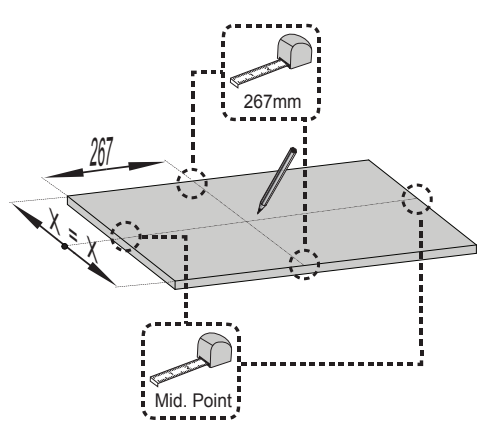

11

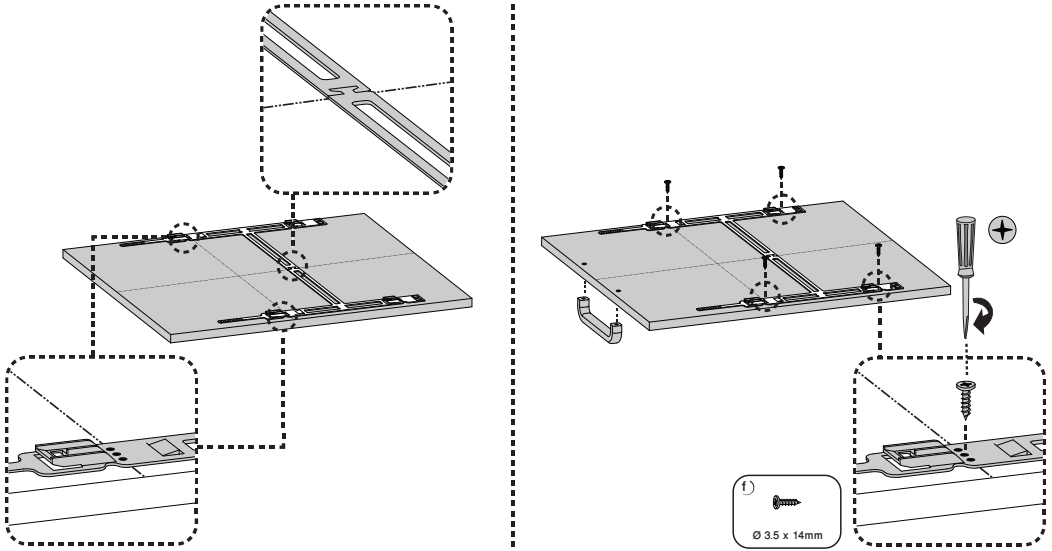

12

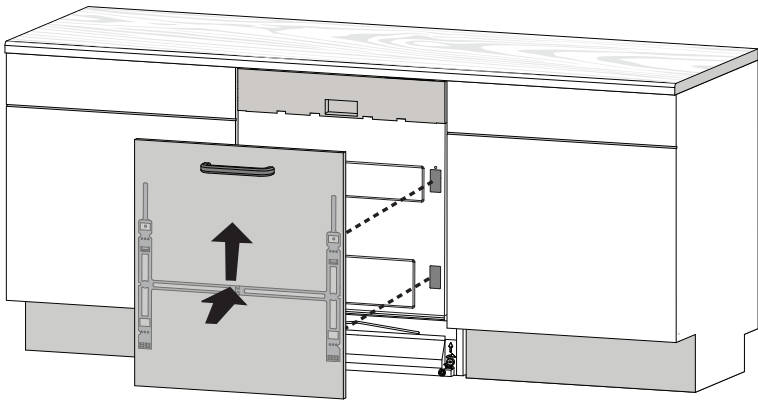





15

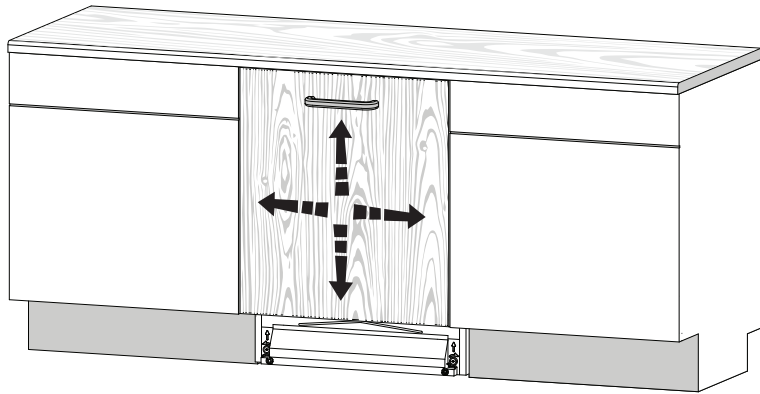

16

