



全漢企業股份有限公司
FSP TECHNOLOGY INC.

台灣桃園市建國東路22號 統一編號：84239055
No. 22, Jianguo East Road., Taoyuan City, Taiwan, R.O.C.
TEL:+886-3-375-9888 Website : www.FSP-group.com
FAX:+886-3-375-6966 Email : sales@fsp-group.com.tw

UNINTERRUPTIBLE POWER SYSTEM

SPECIFICATION

EP450/650/850 Series



FSP GROUP

全漢企業股份有限公司

FSP TECHNOLOGY INC.

台灣桃園市建國東路22號

No. 22, Jianguo East Road., Taoyuan City, Taiwan, R.O.C.

TEL:+886-3-375-9888

FAX:+886-3-375-6966

統一編號：84239055

Website : www.FSP-group.com

Email : sales@fsp-group.com.tw

1.0 Revision Summary

REVISION	SECTION	DESCRIPTION
Rev. A		Formal Release



Table of Contents

1. Introduction.....	4
2. Block Diagram	5
3. Control Power Circuit	7
4. Battery Charger	9
5. Line and Zero-Crossing Detection	11
6. Inverter Operation	13
7. Active Clamp	15
8. Microprocessor (CPU) Control Circuit	16
9. Relay Circuit	18
10. Displays, Audio Alarm and Control Button	20
11. Load Detection Circuit	21
12. Interface Circuit	22
13. Troubleshooting	23



1 Introduction

EP series is a line interactive power system that has a step wave output. It prevents impulse, surge, sag and power outage situations. It provides the UPS output load with a reliable source. It has the following functions:

1.1 Boost:

If the utility voltage drops to line boost activated point*, the AVR will be activated and increase the input voltage by 1.18 times of incoming utility voltage.

*Boost activated point

110 VAC	120 VAC	220 VAC	230 VAC	240 VAC
99 VAC	108 VAC	198 VAC	207 VAC	216 VAC

1.2 Buck:

If the utility voltage reaches to line buck activated point, the AVR will be activated and decrease the input voltage by 0.85 times of incoming utility voltage.

*Buck activated point

110 VAC	120 VAC	220 VAC	230 VAC	240 VAC
121 VAC	132VAC	242 VAC	253 VAC	264VAC

1.3 50/60Hz Automatic Frequency Selection:

The output frequency will automatically match the input frequency (50 or 60Hz).

1.4 Communication Port (USB):

It provides remote shutdown capability via communication port for connected computers.

1.5 Data line/telephone line protection:

The unit provides RJ11 port to provide transient voltage surge suppression (TVSS) for data line or telephone line.

1.6 Cold start (DC start):

The UPS is equipped with DC start function to turn on the UPS without input source.

1.7 Green Power Function:

When the load can hardly be detected in battery mode, the UPS will shut down for energy saving.

This manual contains block diagram, principle of operation, system outline and troubleshooting.

2 Block Diagram

The Block diagram of Vesta series (refer to Figure S-1) is divided into the following parts:

2.1 Main Relay (MAIN-RY):

It's to switch the UPS between line mode and battery mode.

2.2 Boost Relay (BOOST-RY):

At line mode, this is a switch used to boost UPS output voltage 18% when the utility voltage is under line boost activated point. (Refer to Boost activated point table in P.4)

Relay OFF: line voltage is normal

Relay ON: line voltage is [under line boost activated point](#).

2.3 Buck Relay:

At line mode, this is a switch used to lower UPS output voltage 15% when the utility voltage is over line buck activated point. (Refer to Buck activated point table in P.4)

Relay OFF: line voltage is normal

Relay ON: line voltage is over line buck activated point

2.4 Main Transformer (MAIN TX):

The Main transformer has three functions:

2.4.1 Inverter Transformer

It provides voltage to UPS output and performs a full-bridge transformer when UPS is at battery mode.

2.4.2 Boost/Buck

The output coils have an output ratio. Thus the output voltage at boost mode is given by (Boost Relay ON):

$$V_{OUT} = V_{IN} * 1.18$$

The Buck relay is ON when the utility voltage is beyond line buck activated point.

It can lower 15% of input voltage:

$$V_{OUT} = V_{IN} * 0.85$$

2.4.3 Charger:

The battery is charged by the mains through transformer and full-bridge inverter.

2.5 Line Sense

The MCU detect the mains by input voltage and frequency signals converted from the amplifier.



FSP GROUP

全漢企業股份有限公司
FSP TECHNOLOGY INC.

台灣桃園市建國東路22號
No. 22, Jianguo East Road., Taoyuan City, Taiwan, R.O.C.
TEL:+886-3-375-9888
FAX:+886-3-375-6966
統一編號：84239055
Website : www.FSP-group.com
Email : sales@fsp-group.com.tw

2.6 CPU (MOTOROLA/MC68HC908JL8CSP)

The Central Process Unit

2.7 Electricity Switch

It controls the +5Vdc and +12Vdc supplies.

+5Vdc and +12Vdc Control Power Generator.

Provide +5Vdc (generated from 7805 regulator) and +12Vdc power supply.

2.8 Charger:

The source for the Charger comes from the mains through the transformer and full-bridge inverter. The charger is controlled with high frequency technology and the acceptable charging voltage is 13.6~13.9V.

2.9 Inverter Circuit:

The inverter circuit is based on a full-bridge circuitry.

2.10 Interface Circuit:

The UPS display device contains one LED (or three-LED as option) and one switch.

2.11 Batteries:

Acts as a power supply source while the UPS is on battery mode. Different types of batteries are used for different models of UPS:

450VA: 12V4.5Ah *1pc or equal capability

650VA: 12V7Ah *1 pc or equal capability

850VA: 12V9Ah *1 pc or equal capability

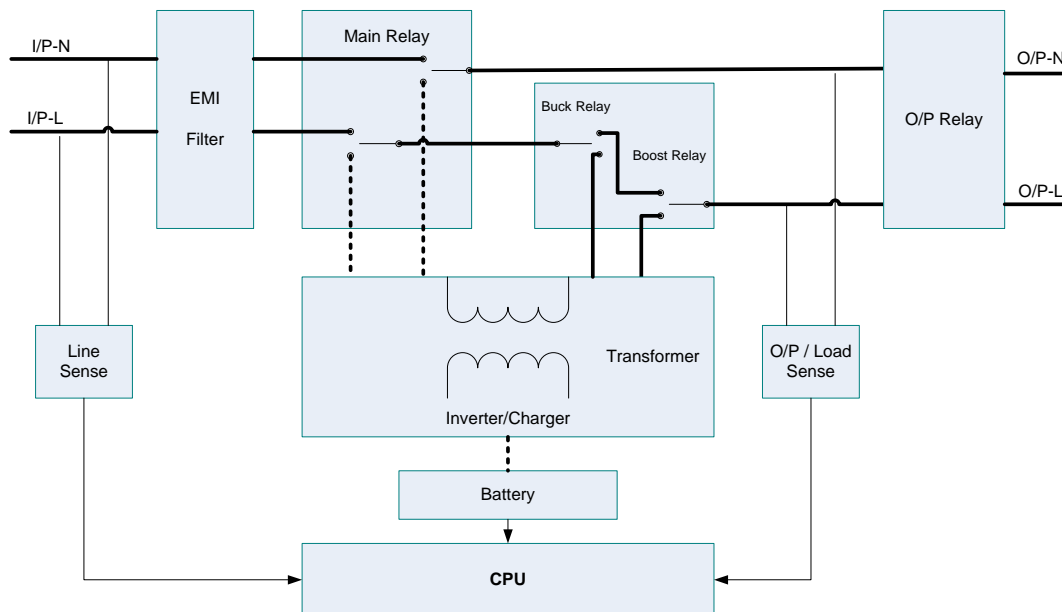

Figure S-1 Block Diagram

3 Control power circuit

The control power (+12Vdc and +5Vdc) comes from the following sources (Figure S-2).

3.1 Start without input AC power (Cold start):

A "Cold start" is described as follows:

- 3.1.1 When "ON/OFF" switch (SW1) is pressed, a positive battery current flows through SW1 to charge C15.
- 3.1.2 Q12 base receives a HI pulse and turn on (signal bypass C15 at t=0, and charge C15 at t>0).
- 3.1.3 When Q12 turns on, the Q12 collector will drop to LOW and turn on Q11 (MPS2907A).
- 3.1.4 When Q11 turns on, the positive battery voltage via Q12 collector and establishes a +12Vdc power supply. The +12Vdc power supply passes through U03 (78L05) generating a +5Vdc logic power supply. And CPU send HI signal (shutdown) to sustain Q12 on.
- 3.1.5 Figure W-1 shows the pulse on the C15, i.e. the base signal of Q12 during the cold start.

3.2 Start with input AC power (AC start):

- 3.2.1 When we connect UPS to the utility, half-wave rectifier will activate Q12 through D2, ZD1, and Q16.
- 3.2.2 If "ON/OFF" switch is pressed, Q11 turns on and establishes a +12Vdc and +5Vdc power supply similar to "Cold start".

The SHUTDOWN network, triggered by pin 15 of the CPU, is used to shutdown the UPS on battery mode. When a battery is in low battery voltage status, the CPU sends a "Low" signal to turn off Q12. This causes Q11 to be turned off and isolates the control power from batteries.

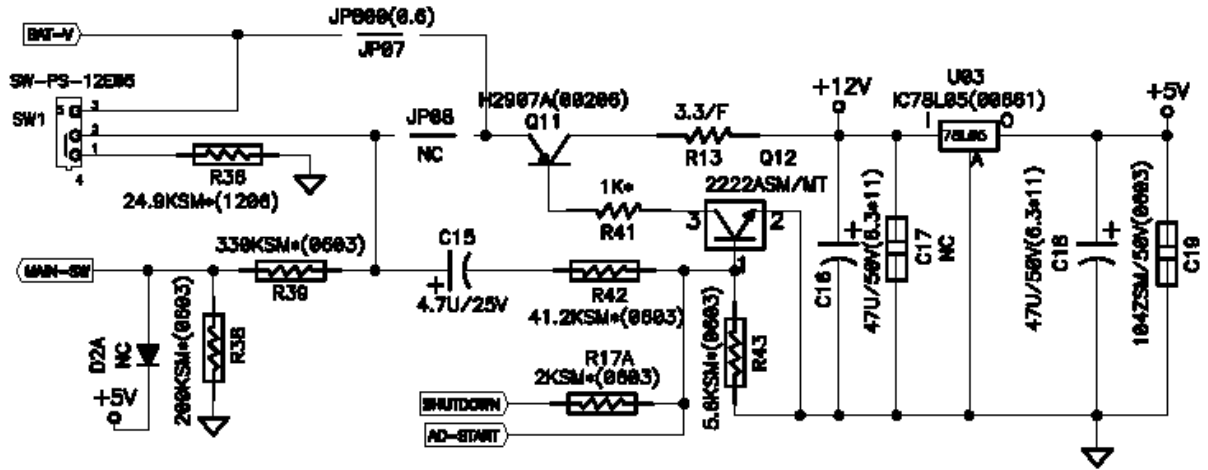
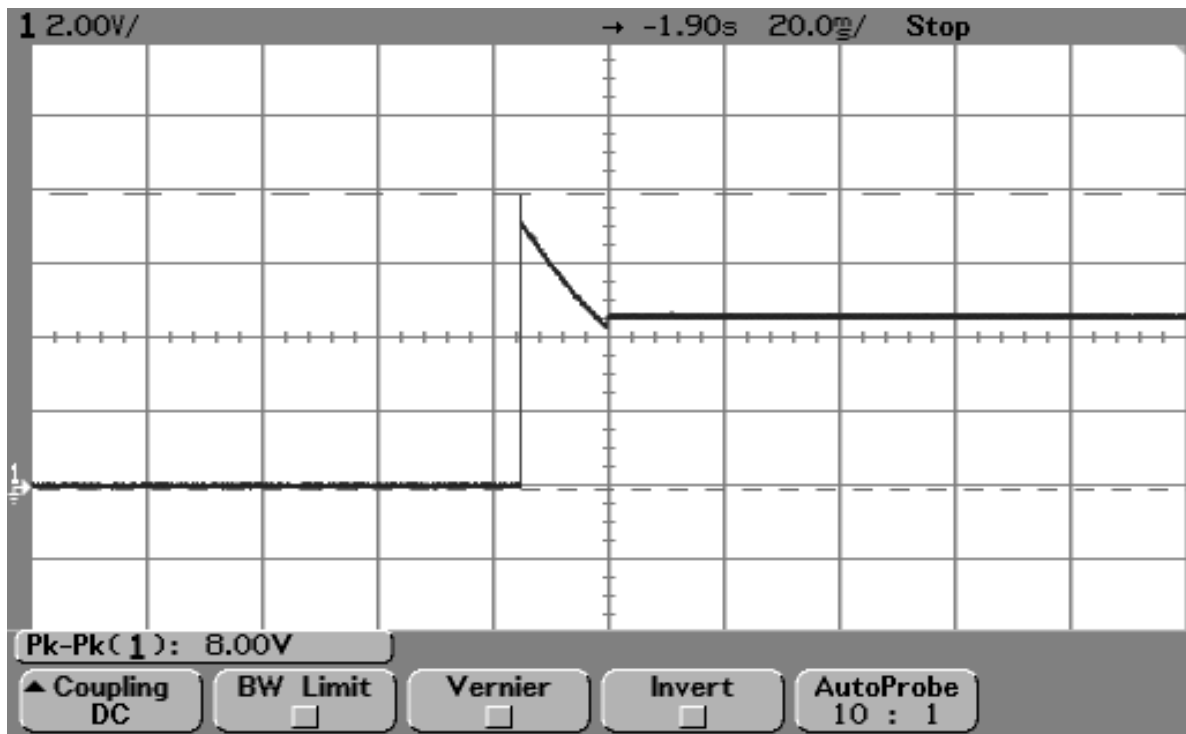

Figure S-2 Control Power Circuit



CH1: C15 → GND

Figure W-1 Cold Start

4 Battery Charger

The flow chart of charger is described as follows: (Figure S-3-A & Figure S-3-B)

- 4.1 When UPS is connected to the utility, the control power (+5Vdc) will be established and the CPU will start to work.
- 4.2 When CPU turns on Main Relay (RY01), the AC power flows into Main Transformer.
- 4.3 Charging current will be generated from the inverter coil of the Main Transformer.
- 4.4 A PWM IC 3843 is used to adjust the charging voltage and charging current. (Refer to Figure S-3-A) The charging voltage can be set by changing the value of R87, R88, R46 and R65. The charging current can be set by changing the value of R14.

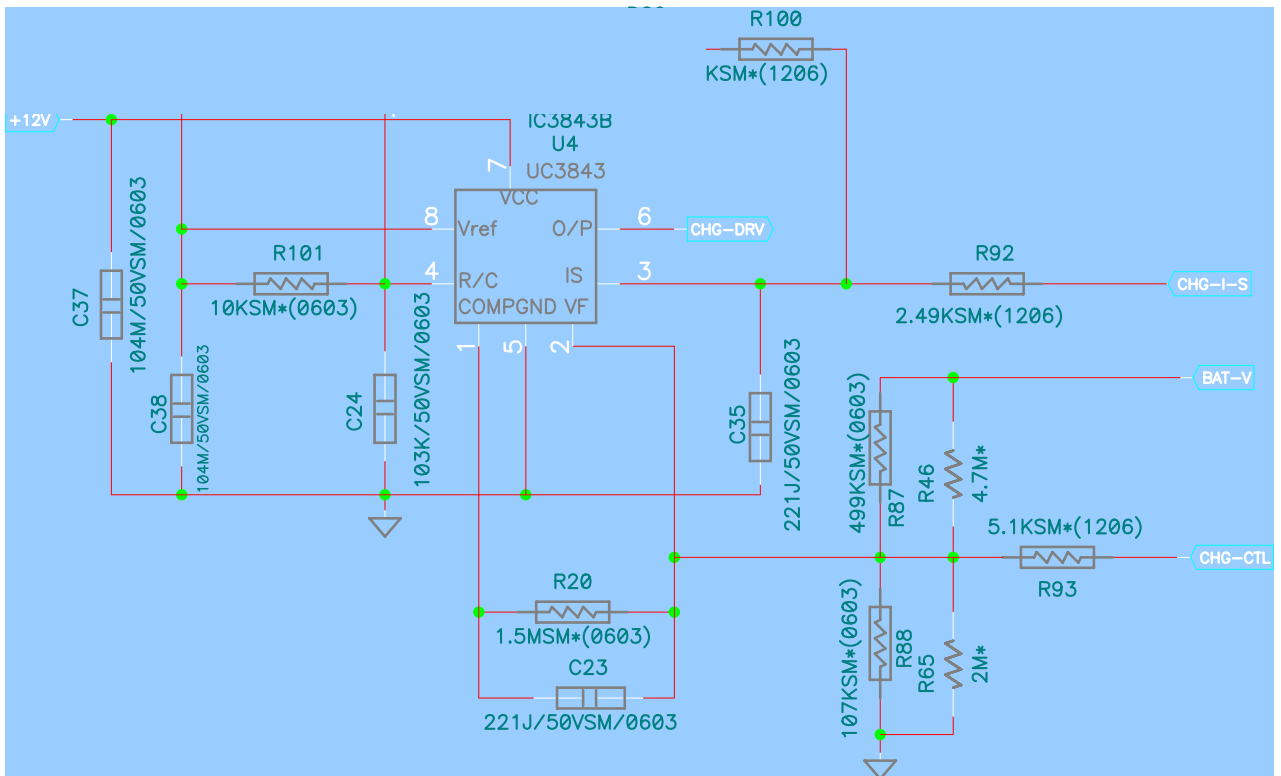

Figure S-3-A Charger Control Circuit

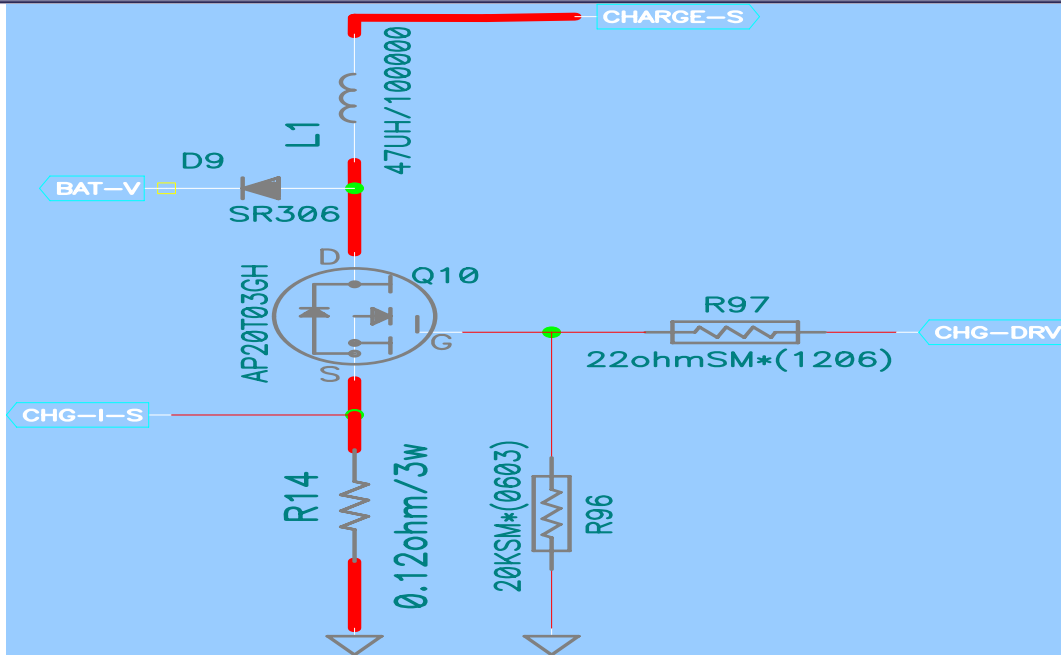

Figure S-3-B Charger Control Circuit



5 Line and Zero-Crossing Detection

Please refer Figure S-4

5.1 Line Detection

The input voltage is fully rectified and generates a signal. The signal will be sent to pin 11 of CPU through a voltage divider at R45, R45A and R40//R47. By monitoring this rectified sinusoidal voltage, the CPU can identify if the utility is normal or abnormal. There are two methods to evaluate if line voltage is abnormal.

5.1.1 Waveform detection:

If breakout occurs, the CPU is able to immediately detect it and transfers to battery mode. The waveform detection has a short response time.

5.1.2 RMS value detection:

CPU calculates input RMS value every cycle. If RMS value is not in acceptable range for 3 cycles, UPS will transfer to battery mode. Compared to waveform detection, although it will take longer response time, the RMS value can be accurately detected.

5.2 Zero Crossing Detection

Zero Crossing Detection is used to minimize the phase difference between the Inverter voltage and the input line voltage while UPS is switched from battery mode to line mode. If the phase difference is too large, it will generate excess energy which may damage the internal passive components such as relays.

The Zero Crossing signal is generated by the following conditions:

- 5.2.1 The signal of Line-I/P is full-bridge rectified waveform from line input. The voltage of Pin 7 of IC324 drive Q14 (2222ASM) on or off.
- 5.2.2 The Zero Crossing signal comes from the collector of Q14 and goes through MCU pin 27.
- 5.2.3 Refer to Figure W-2. The waveform of ZERO-CRO from Q14 collector and Line-I/P.

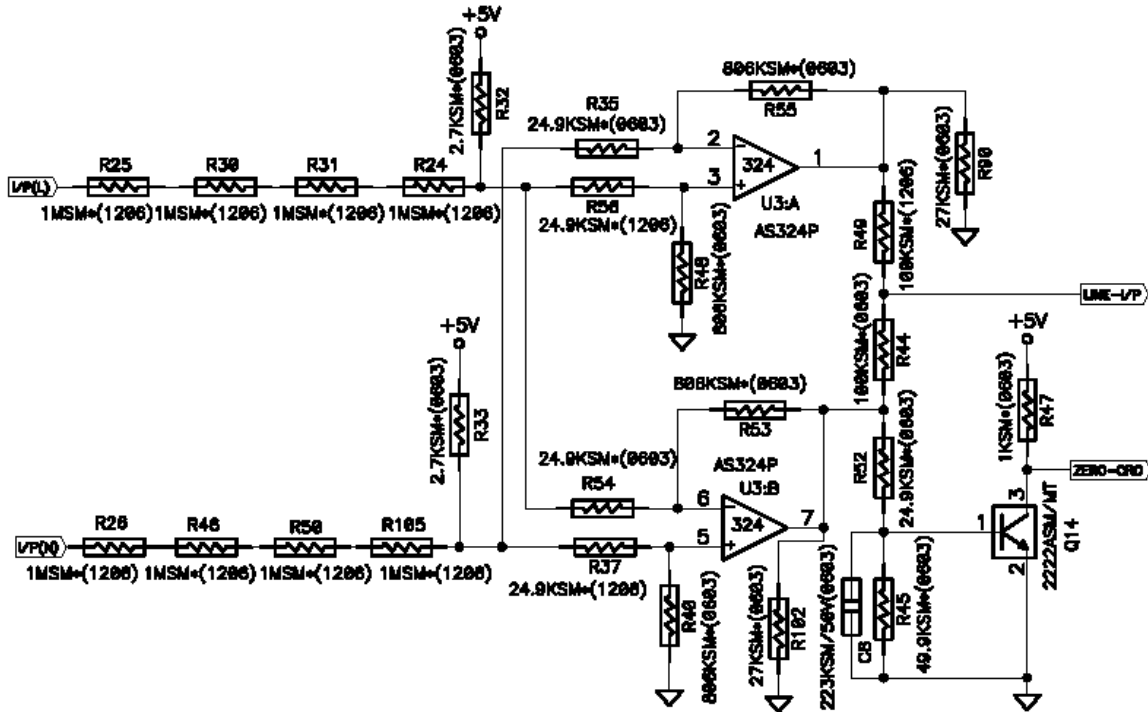
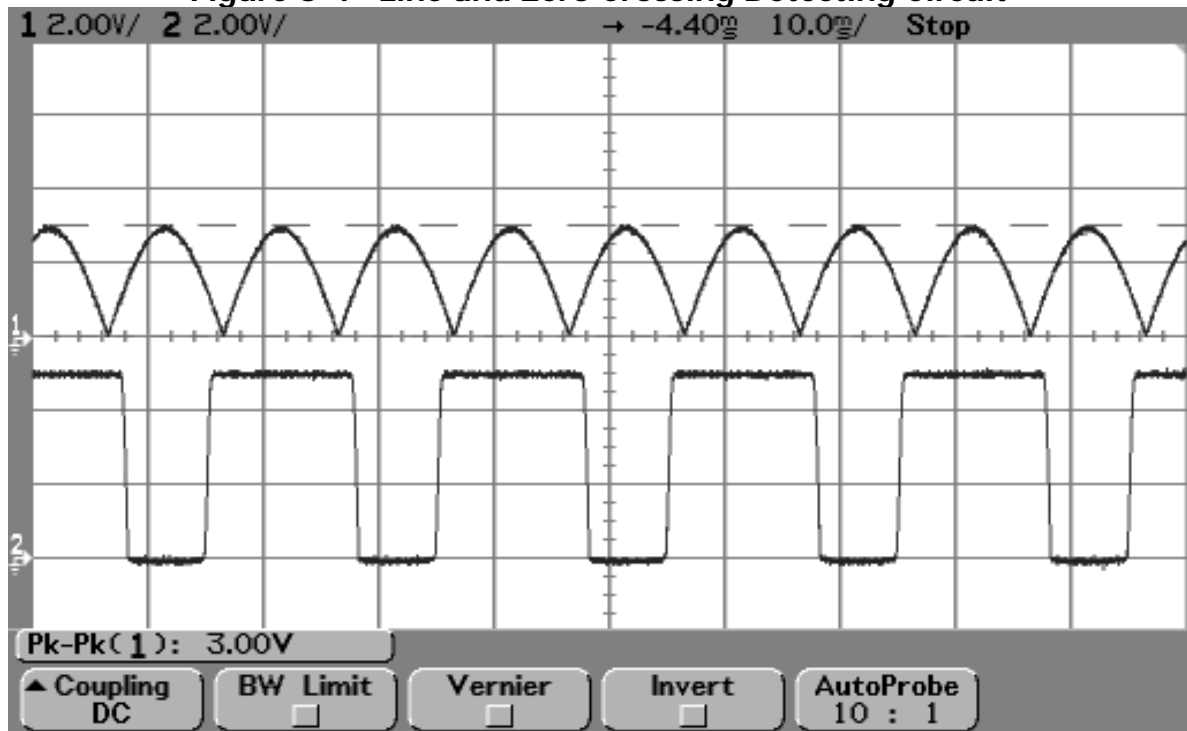

Figure S-4 Line and Zero Crossing Detecting Circuit



CH1: Line-I/P
CH2: Q14 collector

Figure W-2 Zero Crossing



6 Inverter Operation

The Inverter circuit (Figure S-5) and PWM control are only active under Battery mode. The Inverter circuit of Vesta is based on a full-Bridge circuitry and its output is driven by a transistor which is controlled by CPU.

Refer to the Inverter circuit diagram, the CPU.M1, CPU.M2, CPU.M3, and CPU.M4 signals are generated by CPU. Figure W-3 illustrates the waveforms of CPU.M1, CPU.M2, CPU.M3, and CPU.M4 while the system is at no load condition. The duty cycles of CPU.M1, CPU.M2, CPU.M3, and CPU.M4 signals are controlled by returned signal of output voltage (Please refer to Charger circuit) to get a stable output.

The gates of MOSFETs are driven by transistors Q5, Q6, Q7, Q8, which are controlled by the CPU.M1, M2.VGS, M3.VGS, and CPU.M4. Those signals are from CPU pin18, 19, 20 & 21 directly or indirectly. Figure W-3 (1) shows the collector waveforms for CPU pin18, 19, 20 and 21 while the system is at no load condition at battery mode.

These inverter transistors are turned on and off alternately to transfer DC voltage of battery to an AC stepwave output voltage, and then magnifies through the transformer to generate a stable 230VAC output.

According to the diagram shown on "Figure W-3 Control logic (1)", while the driving signal M2.VGS and M3.VGS both get HI simultaneously in battery mode, the step output waveform get approximately zero, which is named CLAMP. In full-bridge circuit, unlike push-pull circuitry having isolated CLAMP circuitry and driven signal, the CLAMP signals are included in inverter drive logic.

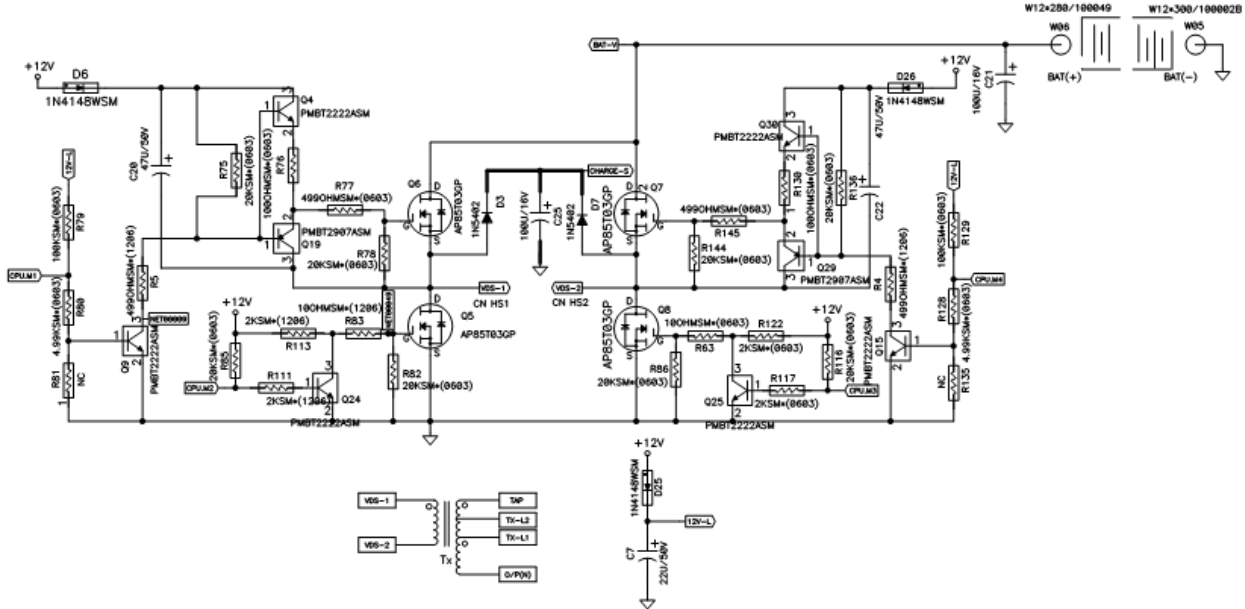
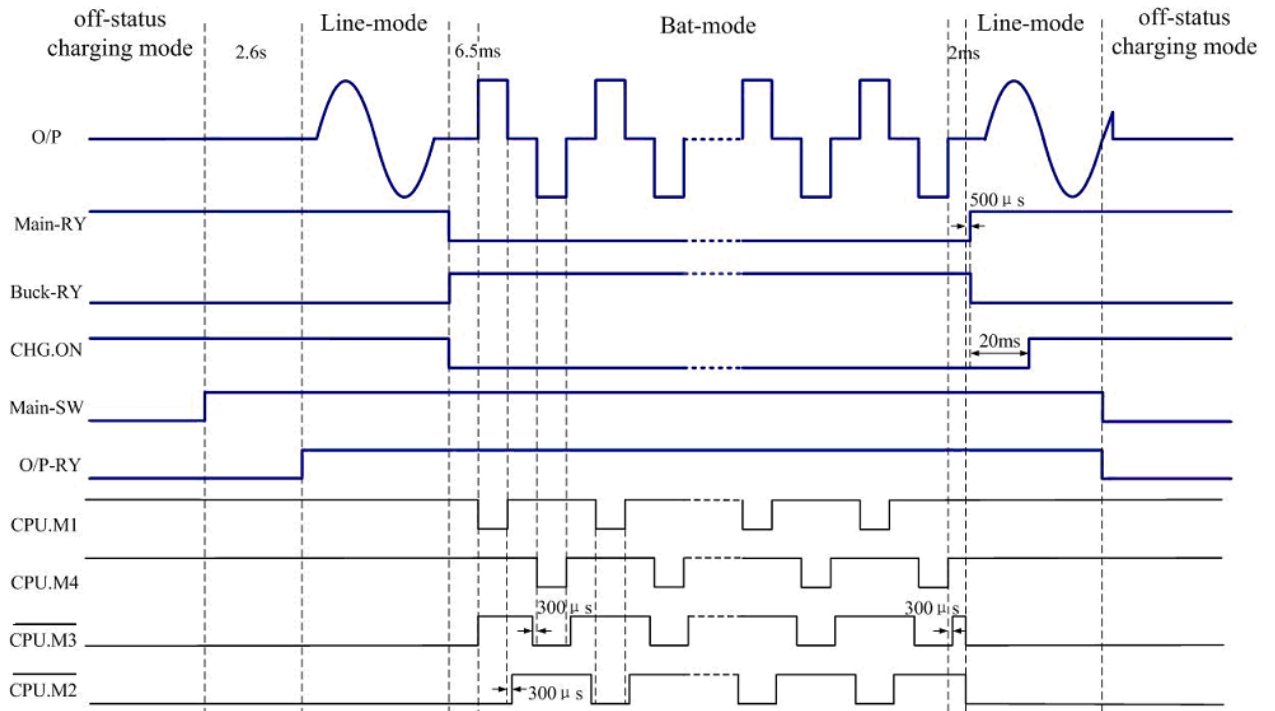

Figure S-5 Inverter circuit



CH1: DS-N
CH2: Output Voltage (1/200V)

Figure W-3 Control logic (1)



FSP GROUP

全漢企業股份有限公司

FSP TECHNOLOGY INC.

台灣桃園市建國東路22號 統一編號：84239055
No. 22, Jianguo East Road., Taoyuan City, Taiwan, R.O.C.
TEL:+886-3-375-9888 Website : www.FSP-group.com
FAX:+886-3-375-6966 Email : sales@fsp-group.com.tw

7 Active Clamp

The purpose of Clamp is to pull down the output voltage while two sets of Inverter MOSFET are OFF. The Clamp effect is active during the period of 0Vac at battery mode. CLAMP principle is shown in the last paragraph of Chapter 6 Inverter Operation.



8 Microprocessor(CPU) Control Circuit

The CPU is supplied by +5Vdc power supply to pin7 with ground pin at pin3. An extra oscillation circuitry consisting of C01, C02, and crystal XL1 is connected to pin4 &5. The Vesta series is using MOTOROLA/MC68HC908JL8CSP CPU. The pin definition is listed below(Figure S-6):

PIN	FUNCTION
Pin1	N/A
Pin2	SW
Pin3	ground
Pin4	oscillation circuit
Pin5	oscillation circuit
Pin6	main relay control
Pin7	Power source
Pin8	series detect (GREEN FUNTION)
Pin9	CHG.ON
Pin10	O/P-V detection
Pin11	Input line detection
Pin12	Load detection
Pin13	RXD
Pin14	TXD
Pin15	Shutdown
Pin16	Buzzer control
Pin17	Battery voltage detection
Pin18	Inverter PWM signal (CPU.M3)
Pin19	Inverter PWM signal (CPU.M2)
Pin20	Inverter PWM signal (CPU.M4)
Pin21	Inverter PWM signal (CPU.M1)
Pin22	VA detect
Pin23	Series detect
Pin24	LED1 control
Pin25	LED2 control
Pin26	LED3 control
Pin27	ZERO-CRO control
Pin28	Buck relay control
Pin29	Boost relay control
Pin30	Reset control
Pin31	O-P Relay
Pin32	Voltage detect

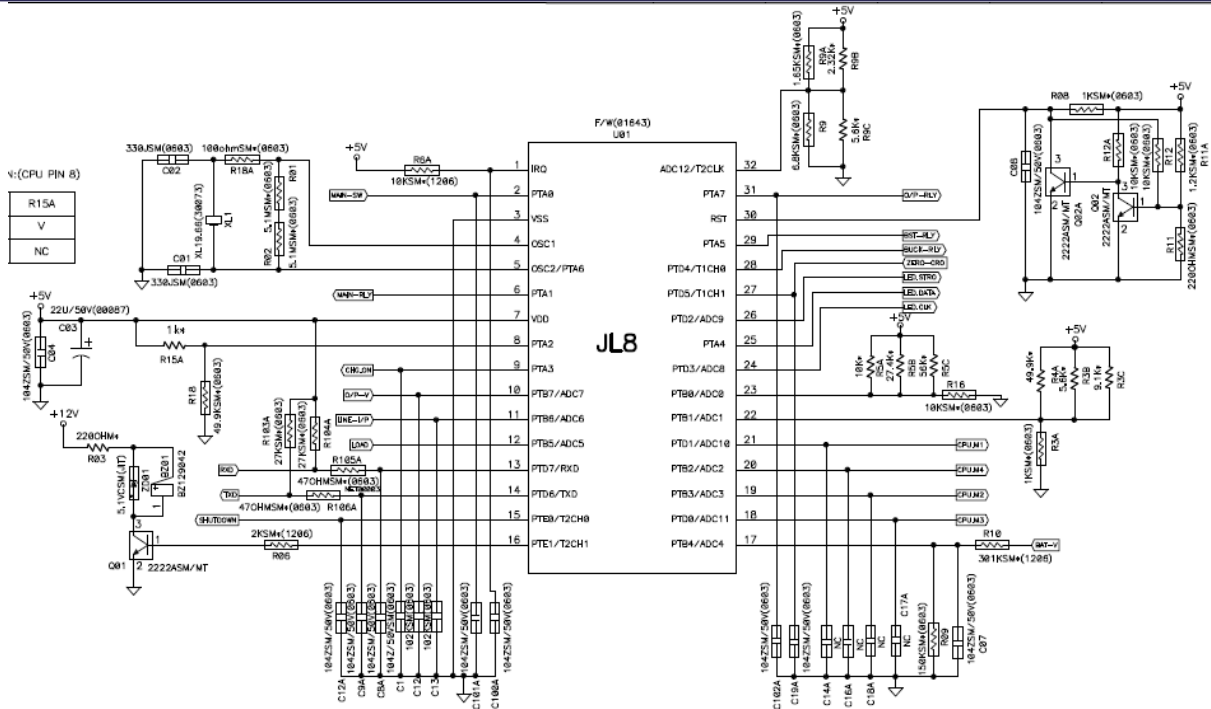

Figure S-6 CPU Control Circuit

9 Relay Circuit

Figure S-7 is the relay circuit.

The RY01 (main relay) is used to switch between line and battery modes. When the UPS is changing from battery to line mode, CPU pin6 is set to HI to turn on Q1AP (2SC1815) and activates RY01. Alternatively, if the UPS is changing from line mode to battery mode, CPU pin6 is set to LOW and turn off Q03. This causes RY01 to be OFF and return to its normal state.

R3AP, D1AP, C1AP and Q2AP are used to speed up the relay transfer action, so the power failure time can be shortened to minimum. When UPS transfers to battery mode, C1AP is charged by the +12 Volts. After the main relay makes contact, C1AP provides instantaneous power to the relay coils. This will increase the magnetic force and shorten the transfer time from battery mode to line mode by switching the relay. See Figure W-6 for voltage changes on C1AP, during transfer time from line to battery mode.

CPU pin29 is used to the drive signal for RY02 (boost relay). When the mains input voltage is low as within boost activated point, pin29 sends a high signal to turn on Q05 (2SC1815). This will activate the RY02, and UPS will transfer to the Boost mode. When the mains input voltage increases back to reach inactivated boost point, the UPS will return to normal mode by sending a LOW signal from pin29. This forces RY02 to switch to its normal position (OFF). At battery mode, pin29 is always set to LOW and RY02 is disabled.

Buck situation is the similar process. CPU pin28 is used to drive signal for RY03 (buck relay). When the mains input voltage rises beyond buck activated point, CPU pin28 sends a high signal to turn on RY03. When the mains input voltage decreases below the inactivated buck point, the UPS returns back to normal mode by sending a LOW signal from pin28.

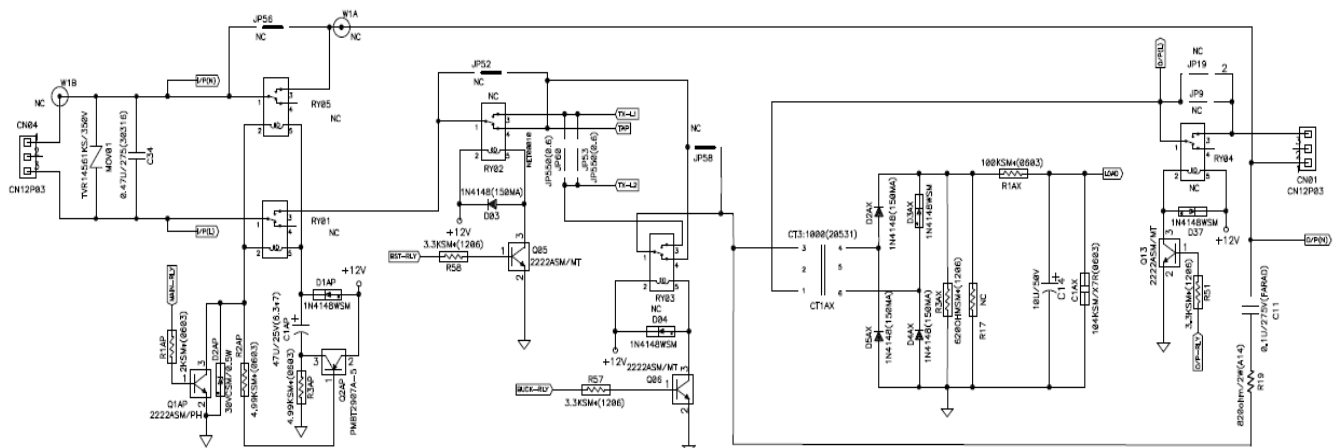
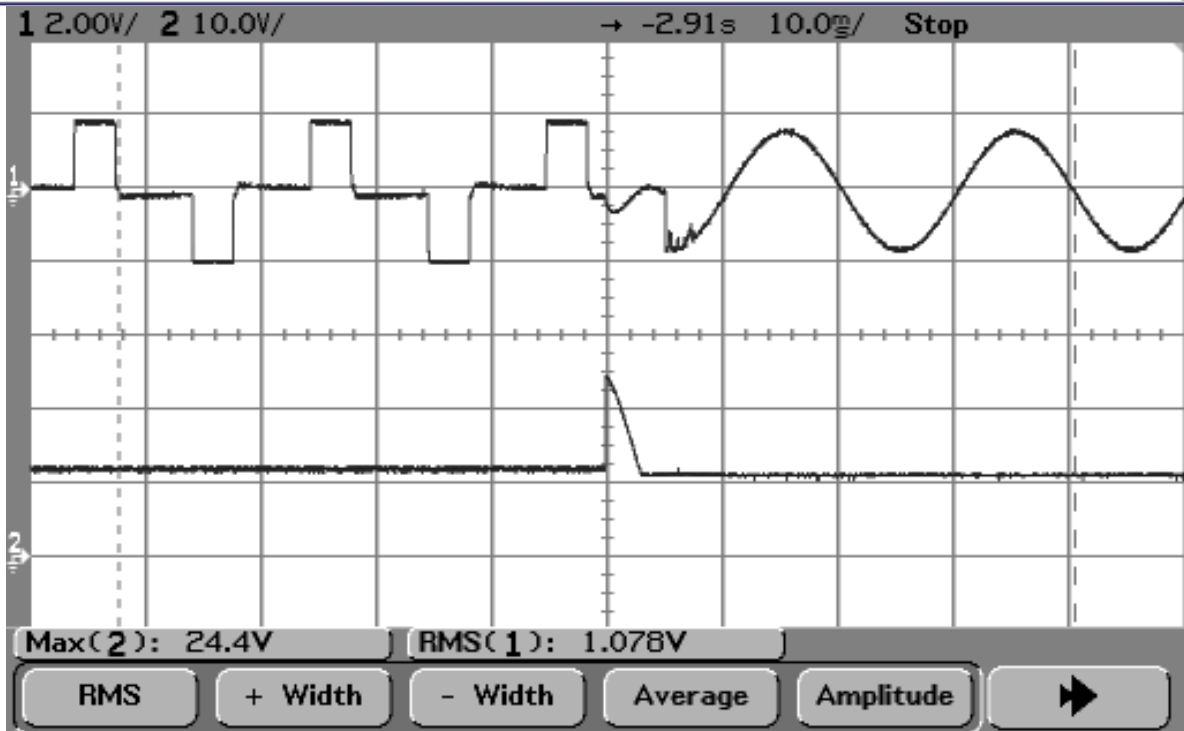

Figure S-7 Relay Circuit



CH1 : C10(+) → GND
CH2 : Output Voltage (1/200V)

Figure W-6 Output waveform vs voltage change for relay speed-up circuitry

10 Displays, Audio Alarm and Control Button

10.1 Control button

ON/OFF Button: Push it to turn on UPS, and push again to turn off UPS. (Please refer to Chapter 3 for cold start & AC start)

10.2 Audio alarm

The buzzer is controlled by pin16 of CPU. When CPU sends a HI signal to buzzer from pin16, buzzer is beeping. And CPU sends LOW signal to stop buzzer.

10.3 Display (Figure S-8)

There are 3 LEDs on front panel.

While control button is turned on, CPU sends a HI signal to turn on LED.

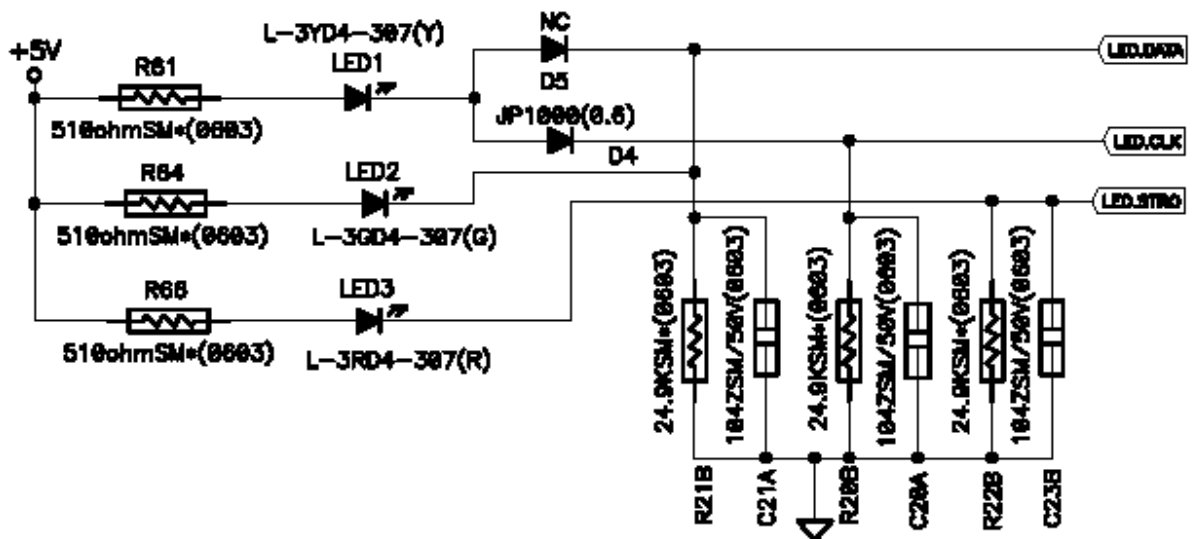

Figure S-8 Display Circuit



11 Load Detection Circuit

Load detection circuit is shown on Figure S-9. The output current is detected by current transformer CT1AX. It lowers 1000 times of output current for CPU detection. The current signal generated from CT1AX flows through a full-bridge rectifier and R3AX to convert to a voltage signal (0~5 Volts). Then CPU can receive output current value of the UPS.

- 11.1 At line/boost/buck mode: The current value multiplies output voltage to get output VA value.
- 11.2 At battery mode: Because the power factor of step wave is approximately equal to 1, the current value multiplies 120V (230V) output voltage to get output Watt value.

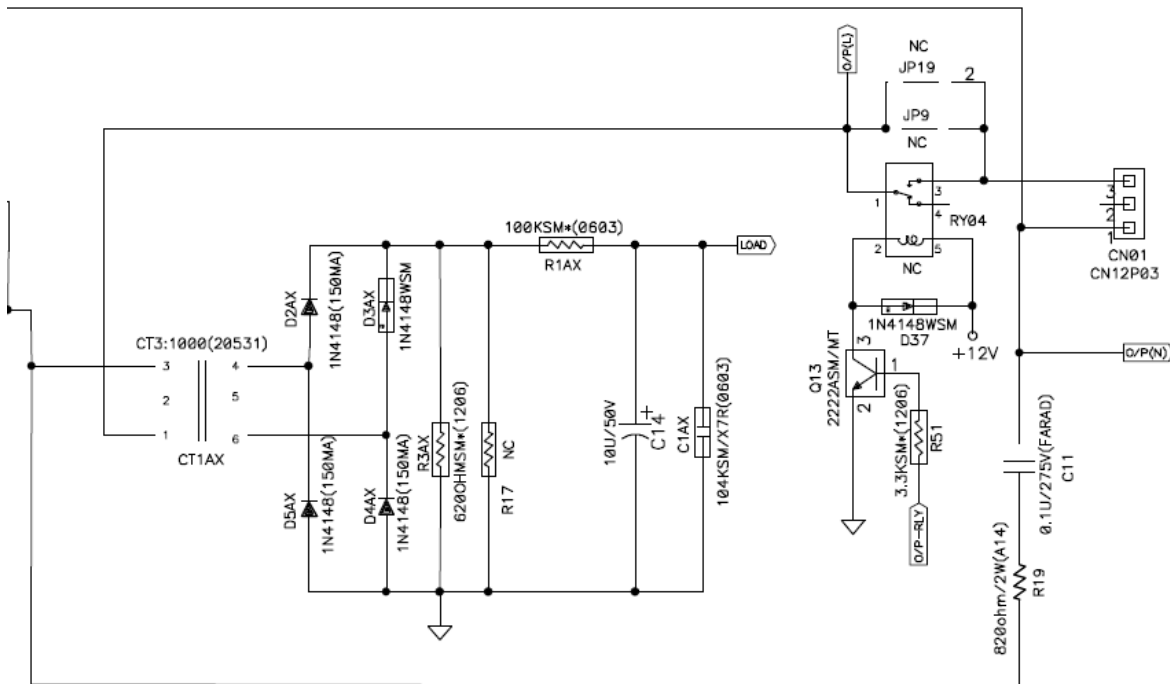

Figure S-9 Load Detection Circuit



12 Interface Circuit

The interface circuit (refer to Figure S-10): USB communication, and plug & play for Windows 95/98/2000/XP/NT.

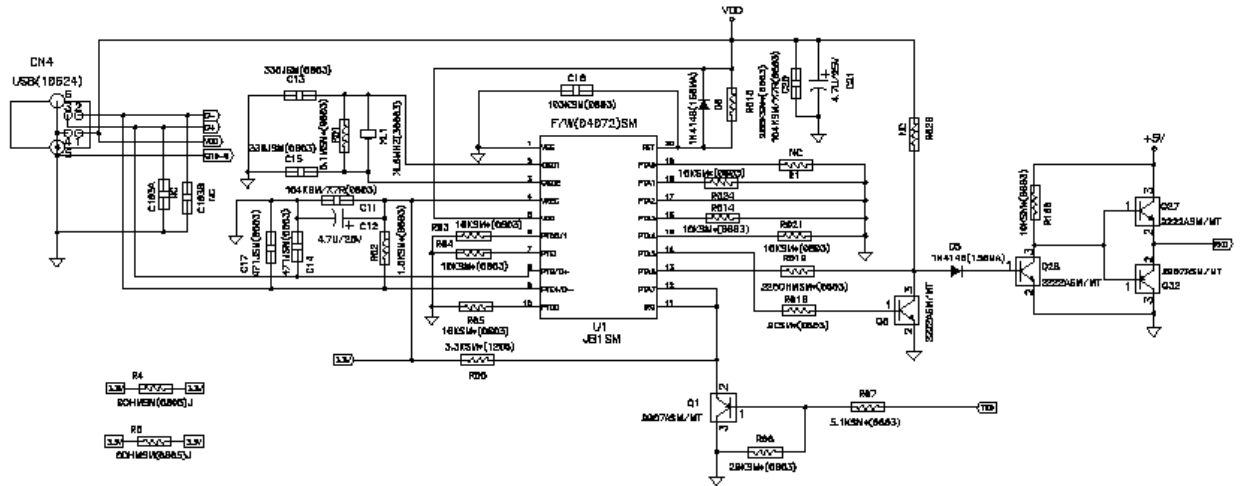

Figure S-10 USB Interface Circuit



13 Troubleshooting

WARNING

- 13.1 Troubleshooting can be done by qualified engineer or technician only.
- 13.2 Use isolated AC source for your oscilloscope to prevent floating voltage problem between UPS chassis ground and system reference ground.
- 13.3 Before opening the cover, turn off the main switch and unplug the input power cord.
- 13.4 Because hazardous voltage may remain in the DC capacitors, wait for at least 5 minutes after turning off the UPS and disconnecting the power cord before open its cover.
- 13.5 Do NOT plug in the input power cord before you reconnect the connectors of battery to prevent unwanted sparks.

Please follow the steps below when you want to repair a problematic unit:

13.6 Visual inspection

This is the first step to check the UPS after opening its cover. Be sure to do the visual inspection because it can help you to identify most problems. Major items that should be checked are listed below:

- 13.6.1 Are there any connectors or terminals loose?
- 13.6.2 Are there any components burn-out or discolored?
- 13.6.3 Especially the power components on the heat sink?
- 13.6.4 Are there any capacitors broken or leakage? Check all the components listed above and replace which is abnormal.

13.7 Troubleshooting flowchart

To prevent from hurting yourself and damaging the UPS, be sure to obey the sequences of flowchart listed below.

13.7.1 Battery mode examination (please refer to Figure W-7)

Procedure:

1. Replace batteries by DC power supply and turn on it. Check if there is current limit phenomenon for DC power supply.
2. One or more MOSFETs (Q5, Q6~8) is D-S short. Check and replace it. If MOSFETs have been replaced once, replace the PCB.
3. Check if both buzzer beeps and LED flash for once.
4. Check if +5Vdc on CPU pin 7 is normal.
5. Check if clock signals on CPU pin4 and 5 are correct.
6. Replace the CPU. But if the CPU has been replaced once, replace the PCB.
7. Replace abnormal crystal XL1.
8. Check if Q18, Q21, Q22 and Q23 are OK.
9. Replace abnormal Q18, Q21, Q22 and Q23.

10. Check if there is a battery voltage on regulator 7805 input.
11. Check Q11 (MPS2907A), Q12 (2222ASM) and replace them if abnormal.
12. Check there is +12Vdc on 7805 input.
13. Replace abnormal Q11.
14. Check there is +5Vdc on U03 (7805)
15. Replace abnormal 7805.
16. Replace PCB
17. Check if buzzer beeps and LED extinguished.
18. Check if battery voltage is correct.
19. Replace abnormal batteries.
20. Check if R17A is normal.
21. Replace abnormal R17A.
22. Replace PCB.
23. Buzzer beeps and LED flash.
24. Check if fault LED lights and buzzer beeps continuously.
25. Check if CPU is shorted.
26. Replace abnormal CPU.
27. Check if the value of R83//R82(or R63//R86) is correct.
28. Replace R83//R82 (or R63//R86).
29. Check if Q4, Q9, Q19 (or Q30, Q29 Q15) are ok.
30. Replace Q4, Q9, Q19 (or Q30, Q29 Q15).
31. Replace PCB.

13.7.2 Line mode examination (please refer to flowchart Figure W-8)

If battery mode examination is OK, then do the line mode examination as below.

1. Plug in input power cord at right voltage range. Check if main relay RY01 is active.
2. Replace main relay.
3. Check if full-bridge rectifier is short.
4. Replace abnormal diode
5. Check Q14 (2222ASM collector) if there is zero crossing signal.
6. Replace abnormal Q14. Check if UPS remains on line mode.
7. Replace PCB.
8. Check if buzzer beeps continuously and fault LED lights.
9. Check if Buck/Boost relays (RY02, RY03) are bad.
10. Replace abnormal Buck/Boost relays (RY02, RY03).
11. Replace PCB.

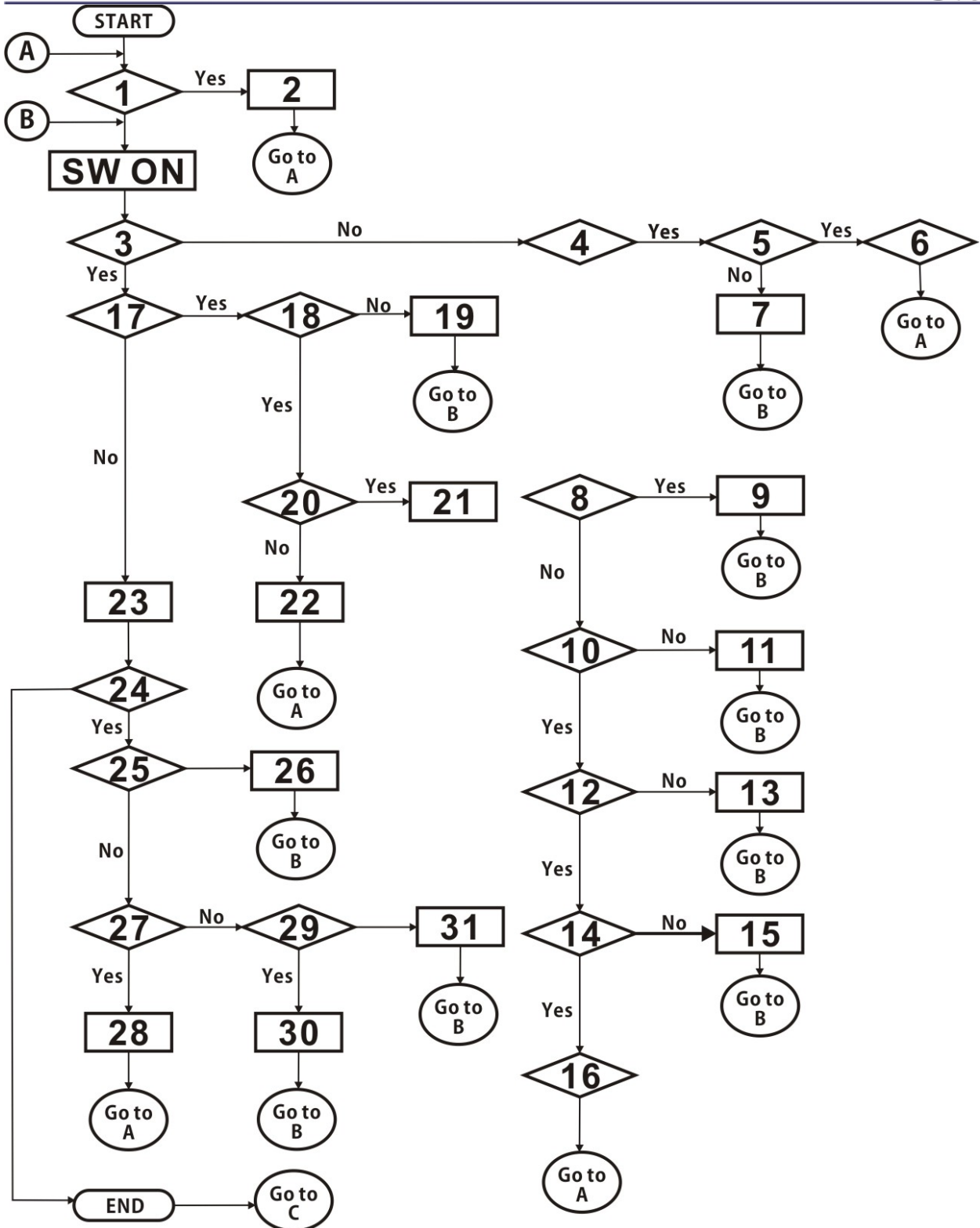

Figure W-7 Battery Mode Examination Flowchart

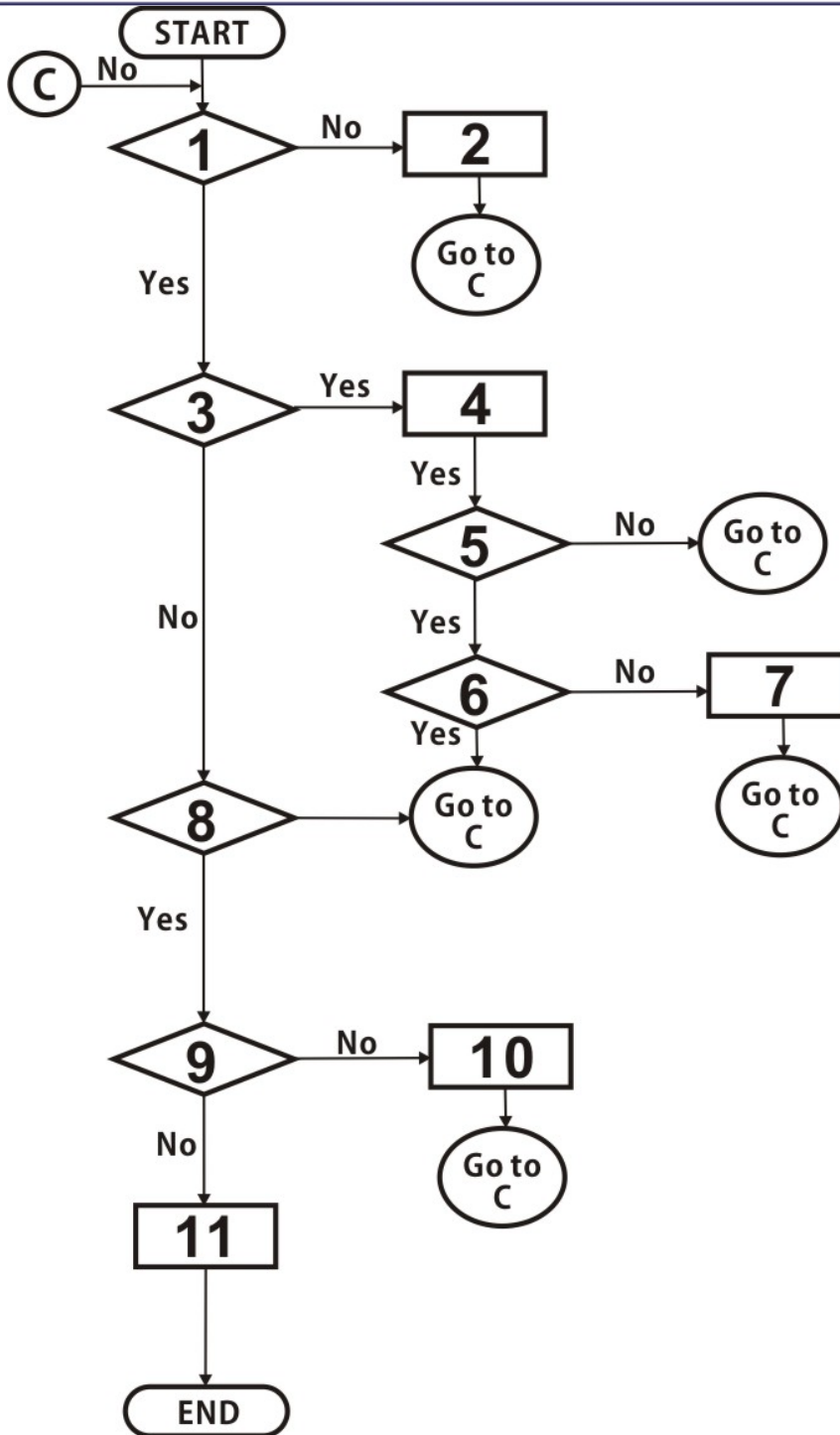

Figure W-8 Line Mode Examination Flowchart