



- 1.
 - 2.
 - 3.
- 12 / 5 (220-240).
- 12 / 5 (110-120)

TM

- 1.
- 2.
- 3.

- 4.
- 5.
- 6.
- 7.
- 8.
- 9.
- 10.
- 11.
- 12.
- 13.
- 14.
- 15.

RU

Fritz Gegauf AG, BERNINA Sewing Machine Manufacturers,
CH-8266 Steckborn/Switzerland, www.bernina.com

-8266 /

RU

ET Onnitlused

Uue õmblusmasina omanikuna tunnend sa rõõmu tapsusest, kvaliteedist ja kõikvõimalike materjalitüüpide õmblemisest, alustades mitmekordsest teksasriietest ja lõpetades kallite siididega.

Su õmblusmasin on lihtne ja kerge kasitseda. Ohutuse tagamiseks, masina paljude eeliste taelikumaks arakasutamiseks ning õmblemise hõlbustamiseks soovitame labi lugeda kõik olulised juhtnõõrid ettevaatusabinõude, kasutamise ja hoolduse kohta kaesolevast kasiraamatust.

Soovitame enne õmblusmasina kasutuselevõttu kõik tema omadused ja eelised enda jaoks avastada, istudes masina taha ja võttes kasoleva kasiraamatu samm-sammult labi.

Pj«qefnict iTiMiu

UZ Tabriklarimizni qabul qiling.

Hipnenniet afKvf-tumuE ar iaunaE

mll7iqu qandan|unnu
^ auciEtaE tua
n^^ultatdE iuEana Etradailot ut
d5iadi;3|jiefiii fiititefiliern -
d5ud7t;RrralnaiTi dinsam itfr
dla^qa 7ids àuduma ; ^|.

JuEU pi«da a
qufjEtakd pa<apti ulenicBria un
« 2pkaiפוianB.
J i/EU droiiPa i un labEaj i>tal
Enlfd? JUEU fna£ma,
reko*Tindeiarn fupiqI i^laEit
VÍEUE I^hniEkdE dfioSibaE,
ti^hnlldaE apkoq» noreikurnuE,
kaE noraditi Eajai i^Etrukclia.

, ka |3U ipirmaja
iulnnaiinai liptoartiE Jue
vari Elei npvfTti: ppc npppiniam
valrakaE taE md» ipaiiPaE.
'SakPt -darPu ar EuimaEinu,
iepa7T£tlPtipE ar inEI^kf'llu. edll
I^a idlitr.

Yangi tikuv mashinasining egasi sifatida Siz eng turli xil materiallarda - ko'p qatlamli jinsi gazlamalardan tortib to qimmatbaho ipak gazlamalargacha tikishning yuqori sifatli natijalaridan rohat olasiz.

Sizning tikuv mashinangiz xizmat ko'rsatishning yuqori darajada oddiyligi va qulayligini taklif etadi. Sizning xavfsizligingiz uchun va Sizning mashinangizdan foydalanishning ko'pgina afzalliklari va qulayliklaridan eng ko'p rohat olish uchun biz bu qo'llanmada mavjud bo'lgan xavfsizlik texnikasi, qo'llanish va texnik qarovga oid barcha asosiy ko'rsatmalarni diqqat bilan o'qib chiqishingizni tavsiya etamiz.

Siz tikuv mashinasidan birinchi foydalanishingizdayoq uning ko'pgina afzalliklarini munosib baholay olasiz, degan umiddamiz. Tikuv mashinasida ishlashga kirishayotganda mazkur qo'llanmaning mazmuni bilan qadam-baqadam tanishib boring

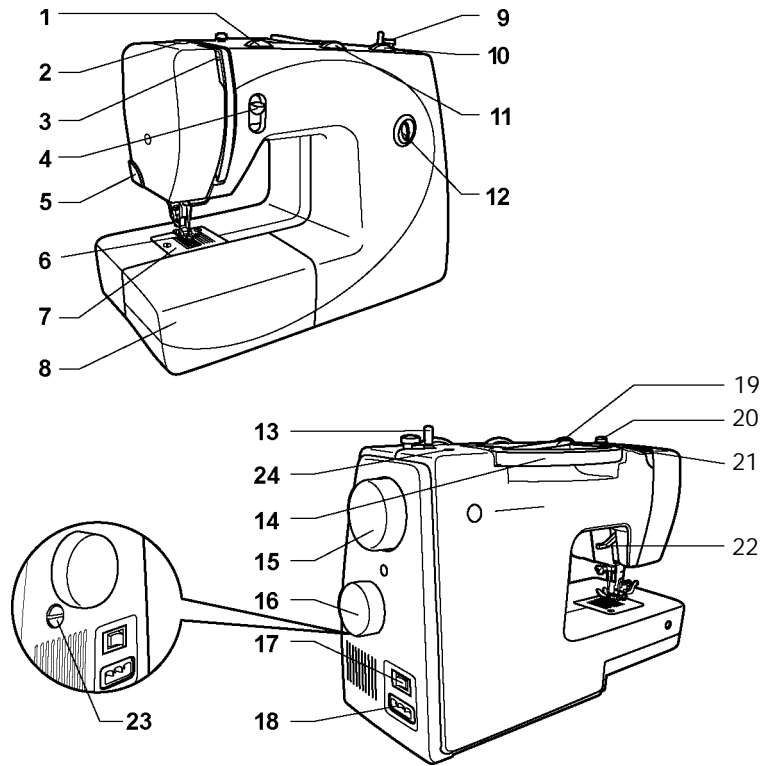

- 1.
- 2.
- 3.
- 4.
- 5.
- 6.
- 7.
- 8.
- 9.
- 10.
- 11.
- 12.
- 13.
- 14.
- 15.
- 16.
- 17.
- 18.
- 19.
- 20.
- 21.
- 22.
- 23.
- 24.

/

55 | 65 | 80e | 90e

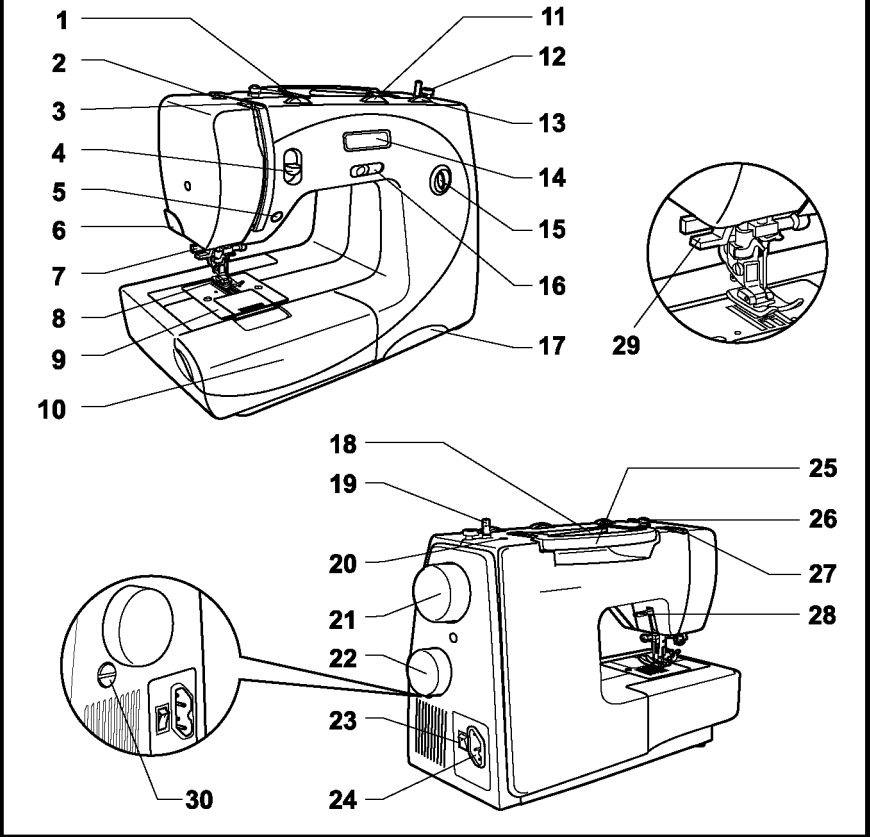

- 1.
- 2.
- 3.
- 4.
5. (80 /90)*
- 6.
- 7.
- 8.
- 9.
- 10.
- 11.
- 12.
- 13.
14. - (90)*
15. (
16. 65/80)*
17. (
- 18.
- 19.
- 20.
- 21.
- 22.
- 23.
- 24.
- 25.
26. /
- 27.
- 28.
- 29.
- 30.
- *

55 | 65 | 80e | 90e

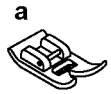

006806008

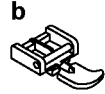

006905008



006914008

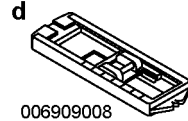

006909008

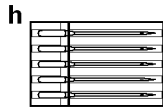
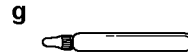
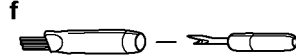
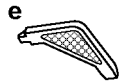

1 006221008

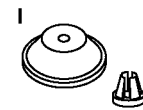
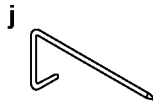

006804008

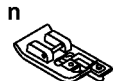

006803008



006800008

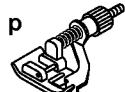

006812008



006810008

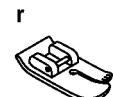

006916008

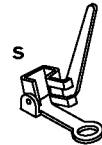

006016008



006917008

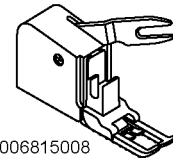

006815008



2

(1)

(3 .)
(3 .)

(2)

0.
8.
1.
V.



55 | 65 | 80e | 90e

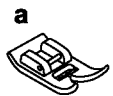

006918008

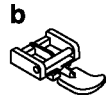

006905008



006914008

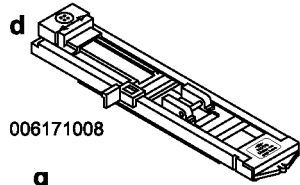

006171008

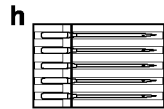
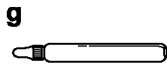
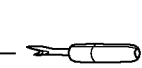
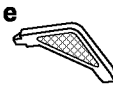

006221008

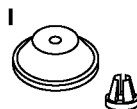

1



006172008



006907008



006900008

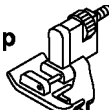

006904008

006813008

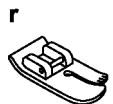

006916008

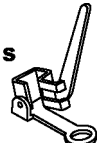

006016008



006917008

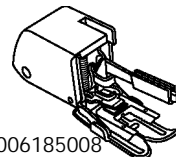

006185008

(1)

" "

(3 .)
(3 .)

(2)

0.
.
8.
1.
V.

RU

55 65 80e 90e

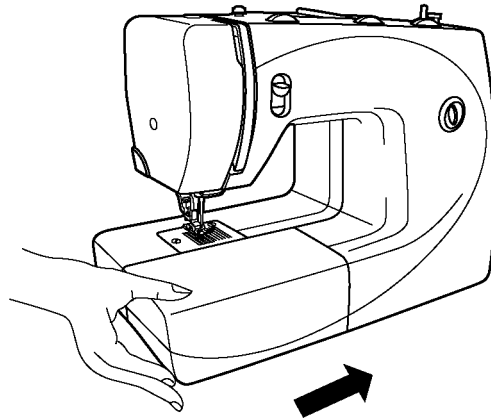

1

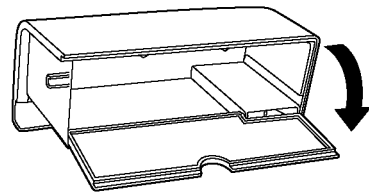

2

(1)

(2)



55 | 65 | 80e | 90e

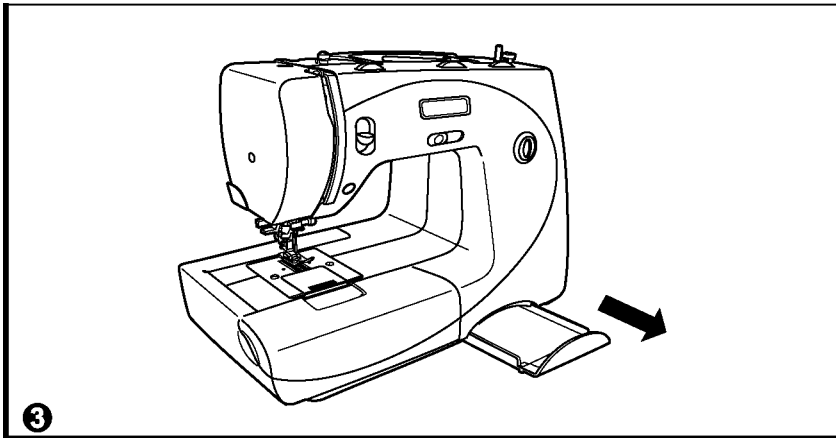
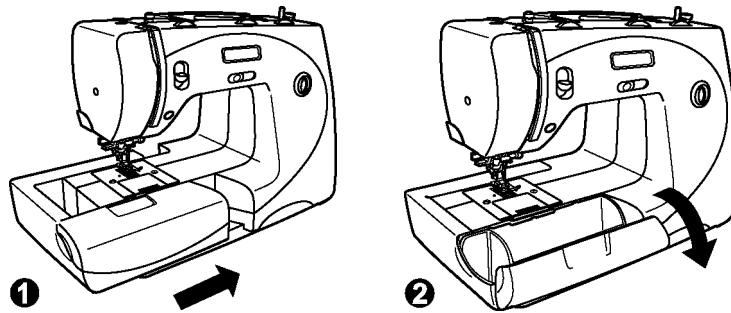

RU



.(1)

(2)

RU



.(3)

(Practical Stitches) =

(Decorative Stitches) =

(Stretch Stitches) =

(Quilt Stitches) =

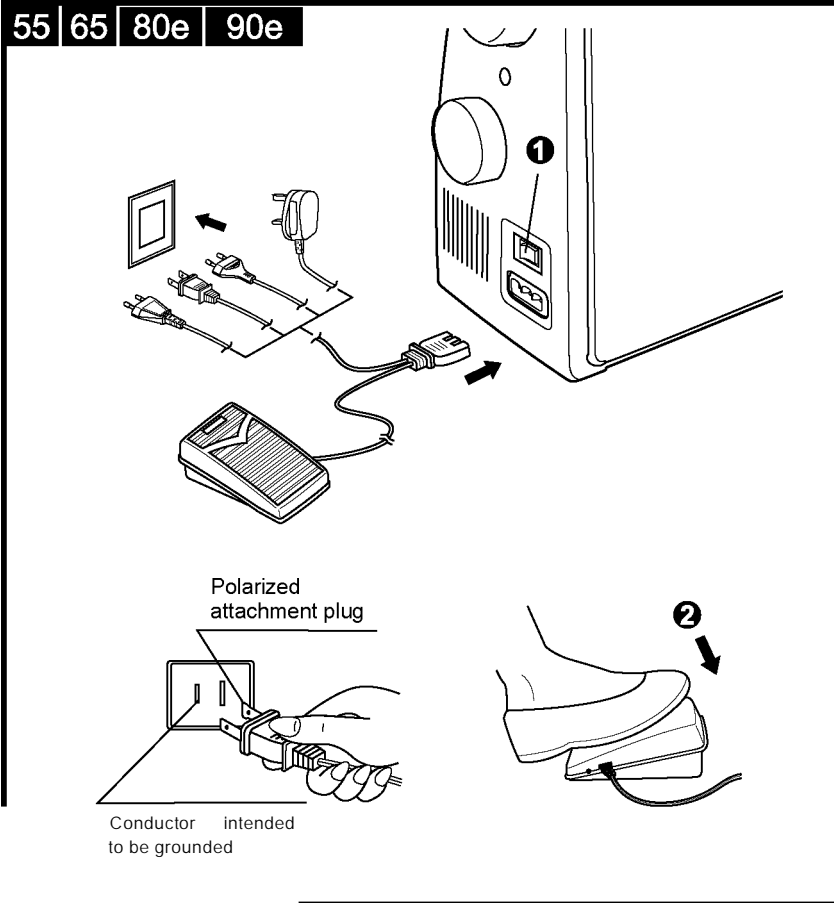

(1)

(2)

315 (100), 4 -316 (4 -
110-120), 4C-326G (230V), 4 -326
(220/240),
MATSUSHITA ELECTRIC (TAIWAN)
LTD.

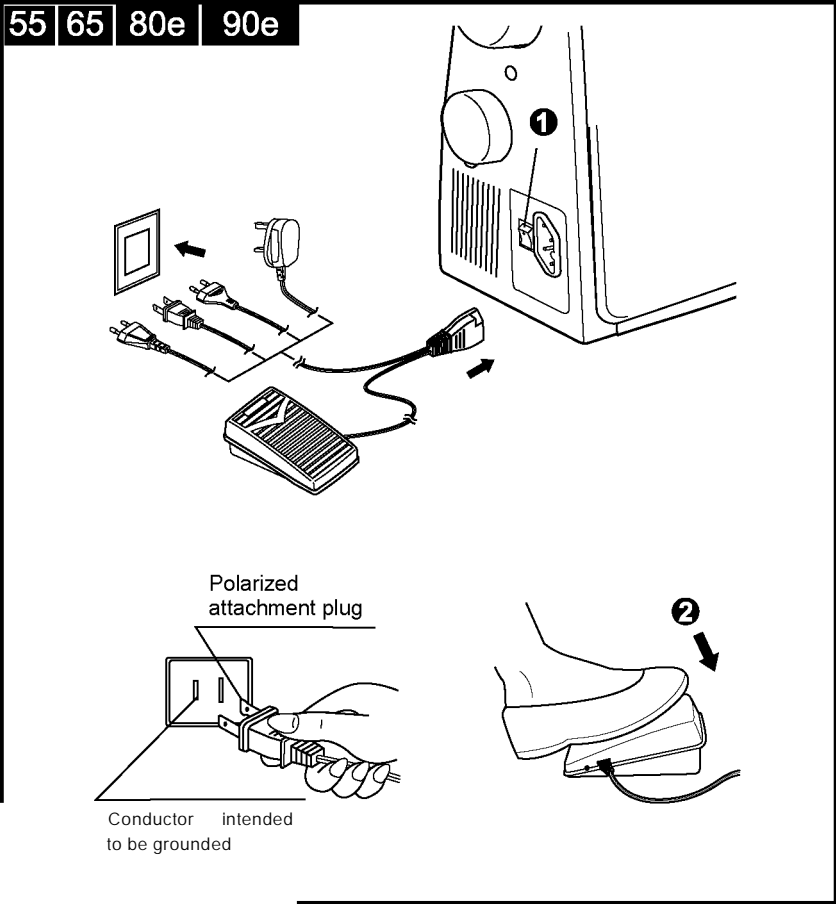

(1)

(2)

337 (100), 4 -337 (4 -
110-120), 4C-337G (220-240),
MATSUSHITA
ELECTRIC (TAIWAN) , LTD.

55

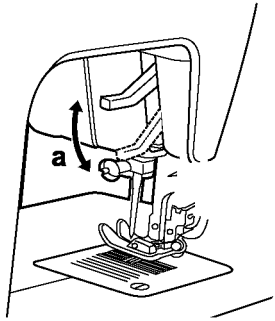

65

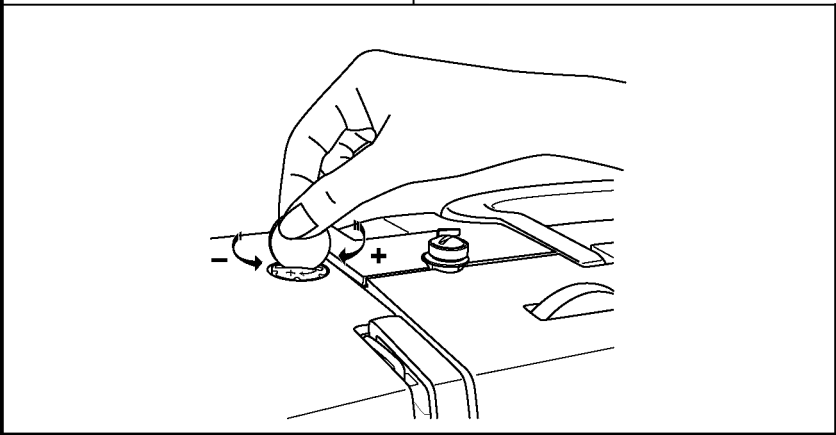
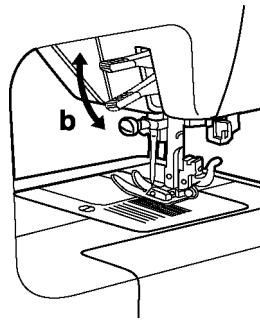



RU

55 | 65 | 80e | 90e

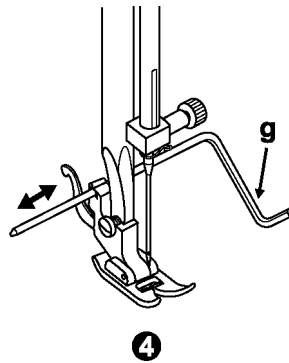
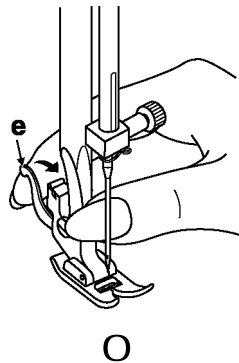
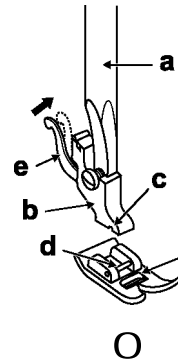
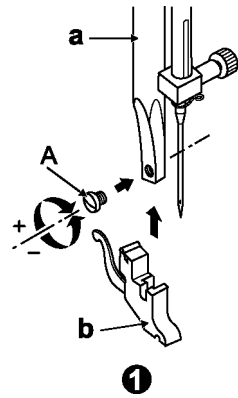

:

" "

(.) (1) (.)

(.) (d) (2) (.) (1)

(.) (3) (.)

(4)



RU [Redacted]

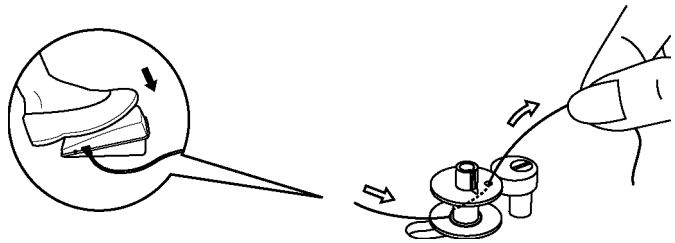
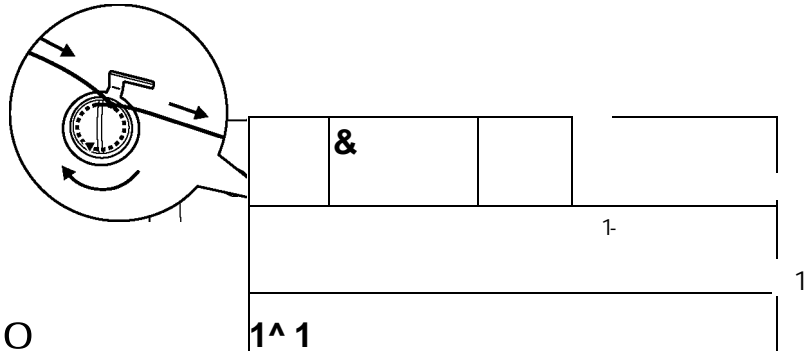
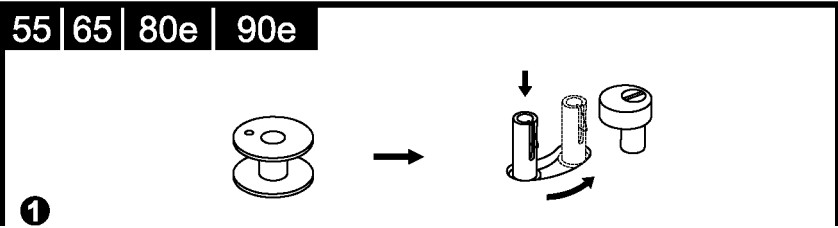

- 1.
- 2.
- 3.

()

55 | 65 | 80e | 90e

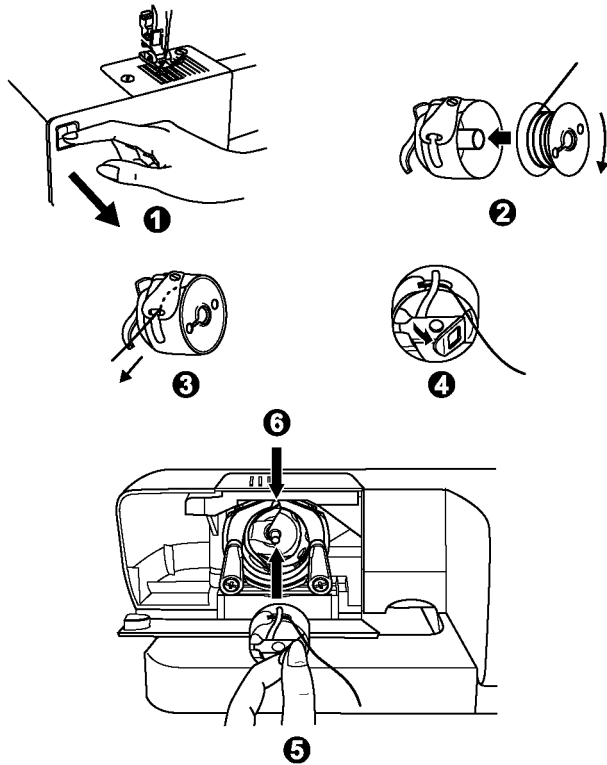

(1).

() (2).

(3).

(4).

(5).

(6).

" "



RU



55 | 65 | 80e | 90e

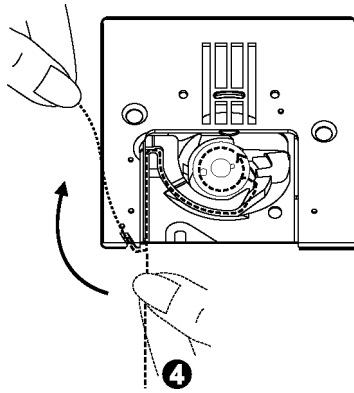
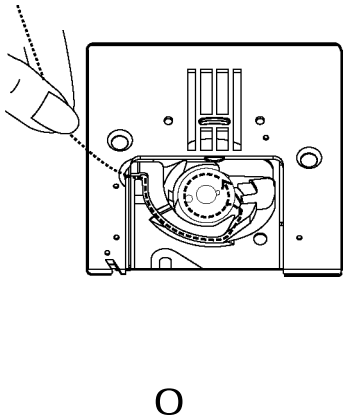
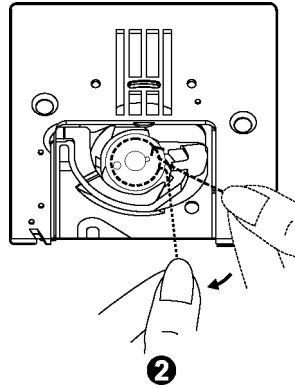
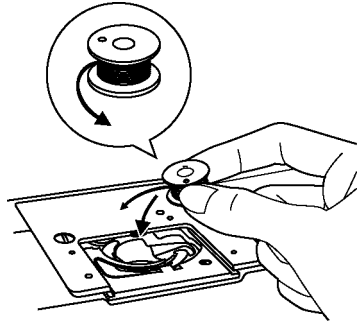

(1)

(2)

(3)

(4)



RU 

55 | 65 | 80e | 90e

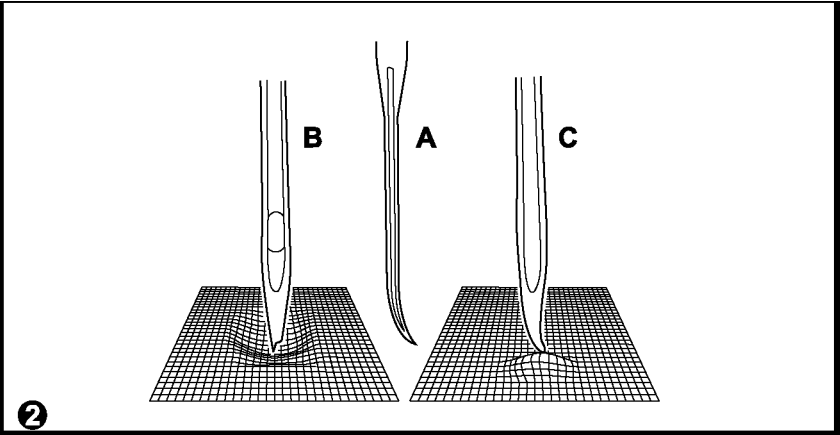
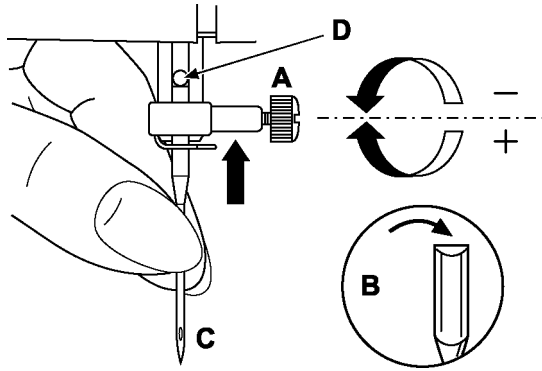

:

" "

A.

. (1)

B.

/

. (2)

A.

B.

C.



RU



55 | 65 | 80e | 90e

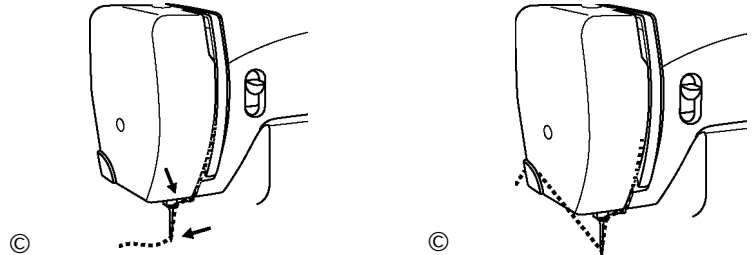
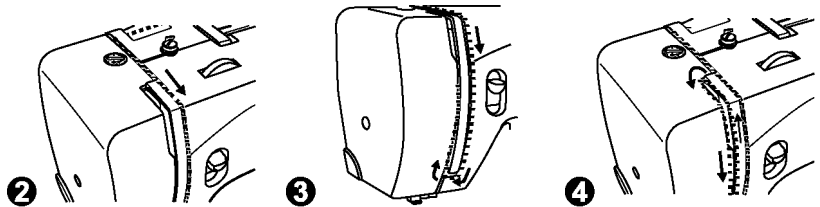
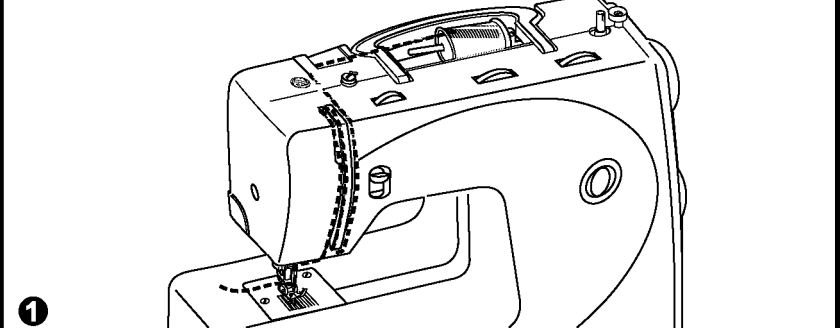

:

" "

(1-5)

(5)

10

(6)



RU



55 | 65 | 80e | 90e

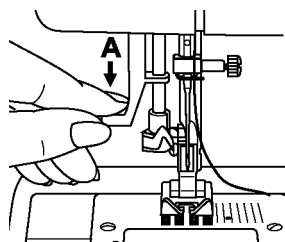

1

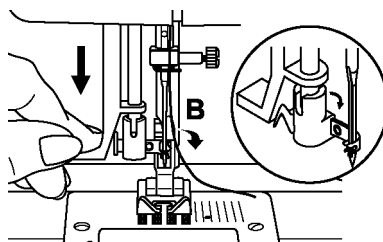

2

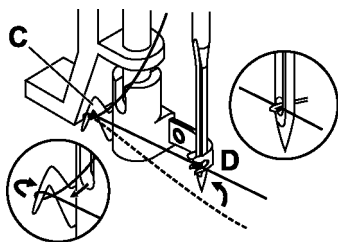

3

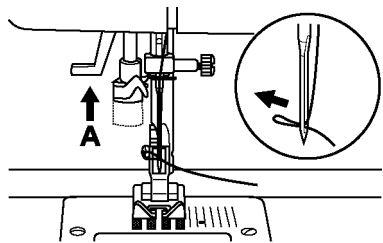

4

()
()
()
()

" "



RU

55 | 65 | 80e | 90e

: "4"



& 5-^^

- A.
- B.
- C.



JL L L L L L I



RU



55 | 65 | 80e | 90e

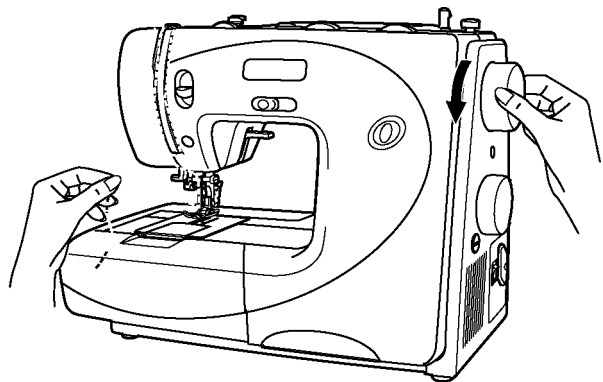

1

(1)

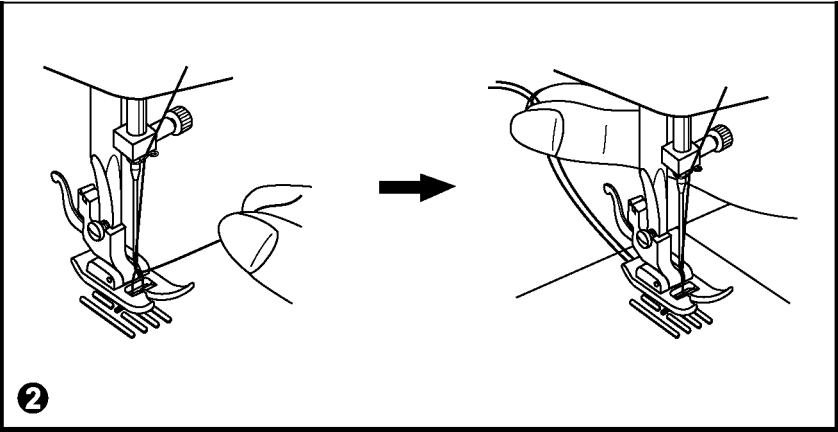

2

(2)



RU

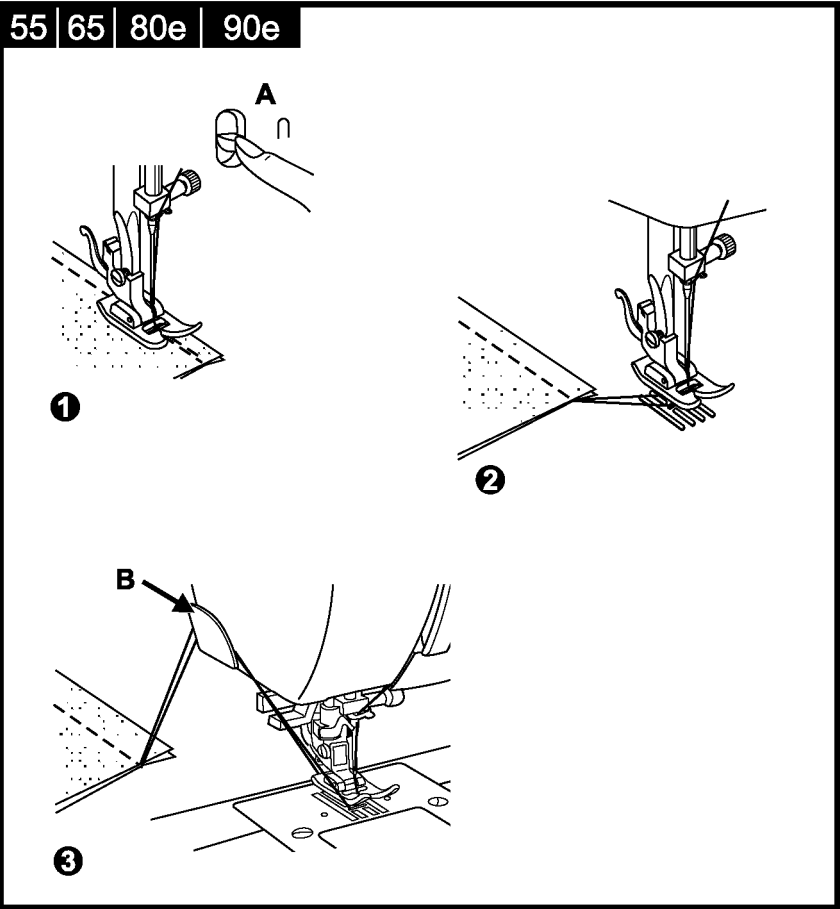

(.)

(1)

(2)

(3)

(.)



RU

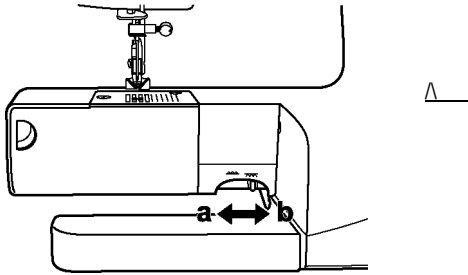

65 80 90

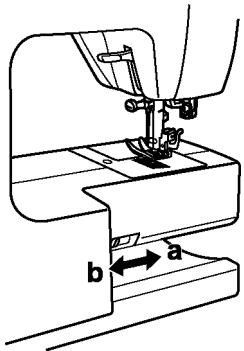



55 65 80e 90e

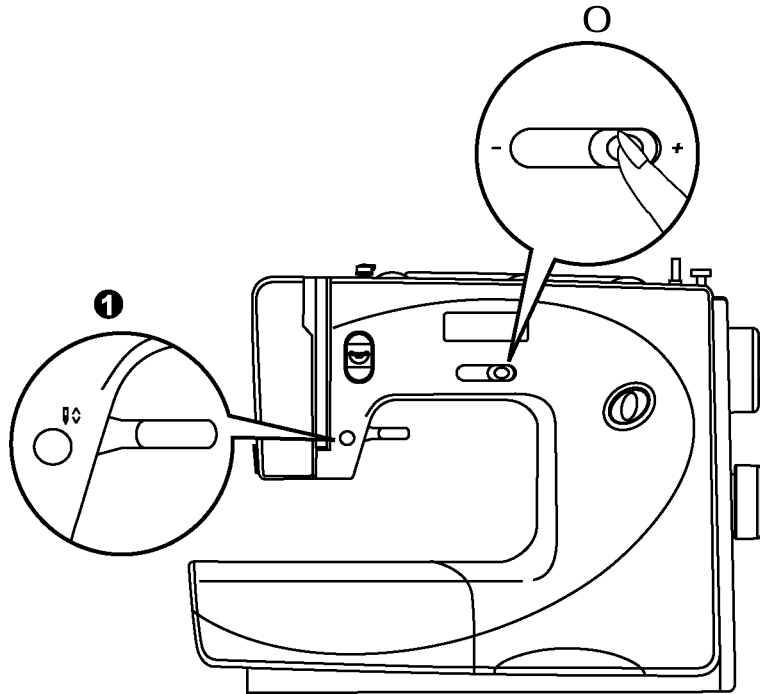

RU

(1).



(2) ("−"), ("+")

"−" =
=



55 | 65 | 80e | 90e

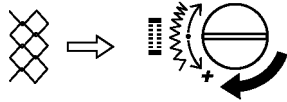
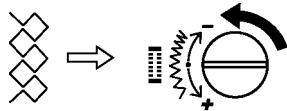
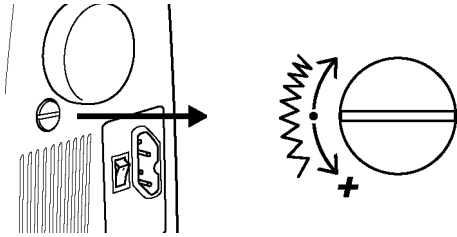

○

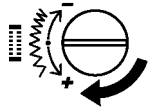
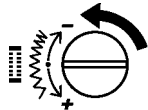

" "

()

(1)

(2) "-"

(2) "+"

(3) "-"

(3) "



9-1 1 (65-75)
12 (80)
14 (90)
16 (100)
18 (110)

1
15 1 9 (65) 18 (110)
15 1/ 9 (65) 18 (110) 130/705
15 1/ 9 (65) 18 (110) 130/705 ()
130 1/ 12 (80) 18 (110) 130/705 -1 /11



- 1.
- 2.
3. : 65, 70, 80 ; "2.5" (55) "4" (65/80 /90). : 9, 11, 12 . . .
4. () /



RU



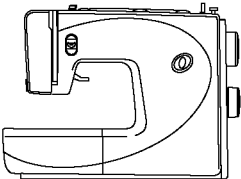

55

1 2 3 4 5 6 7 8 9 10 11 12 13

65

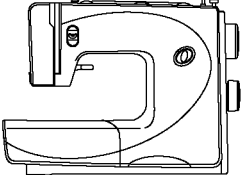
1 2 3 4 5 6 7 8 9 10 11 12 13 14 15

80e

1 2 3 4 5 6 7 8 9 10 11 12 13 14 15
S

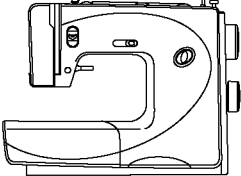
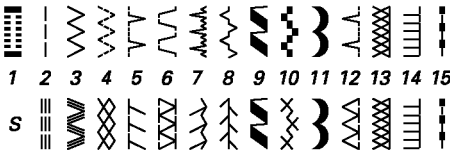
90e

1 2 3 4 5 6 7 8 9 10 11 12 13 14 15 16
S

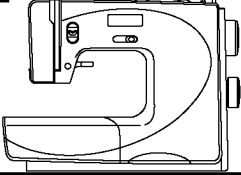
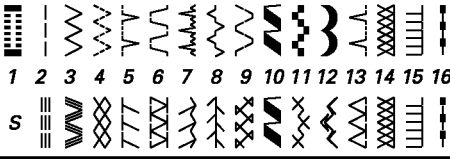
_____ " | "

_____ " | "

) (.

ö"

(80 /90)

RU



(1)

- a.
- b.
- c.
- d.

"02" (2)

```

:
- :
: "2 5^ 4"
:
( "0" ~ " " ):
: " "
- 8
:
: "8"
( "0" ~ " " ):
: " "

```

02
|
|

0 0-7 0 2 5-4 0
|||11 — 1]02

02
|
|

0 0 7]0 205-400
—^ 02

02

0|0 7 0| []5
1 11===== 02

O



- "8" (3)

		\ ^ 0.0-7.01111 ===== 02	5		\ ^ 3.0-7.0		8	\ ^ 3.0-7.0 03 III 04	8
V ^ 3.01 .0	8	Vv^ 5.0 06 1 05	8	V^ 3.0-7.0	8	3.0-7.0	8	3.0-7.0	8
\ ^ 3.0-7.0	8	V^ 3.0-7.0	8	3.0-7.0 1111	8	V^ 3.0-7.0	8	3.0-7.0	8
3.0-7.0 1 III \7\7\7 13	8	Vv^ 3.0-7.01111 14	8	Vv^ 3.0-7.0 15 III ===== 16	8	3.0-7.0	8	3.0-7.0	8



RU

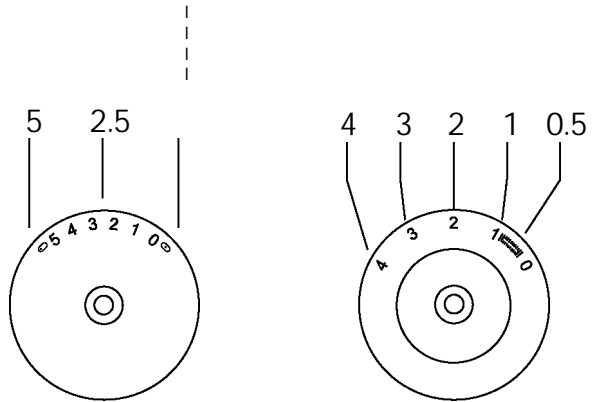
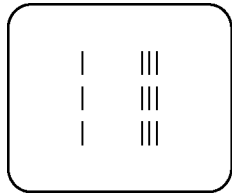

"2" - "3".

"0"

RU

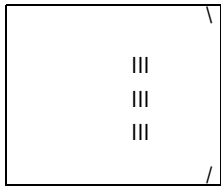

0.0 | ;^0 | 2 5-4.0
1 11-1-02

0!70 7!0|||||8|
| | |=====|02

"2" - "3".

\ ^

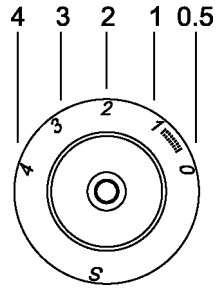
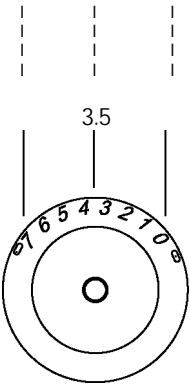

" "



RU [redacted]

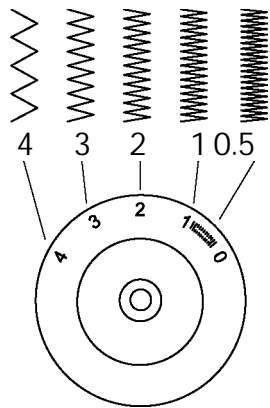
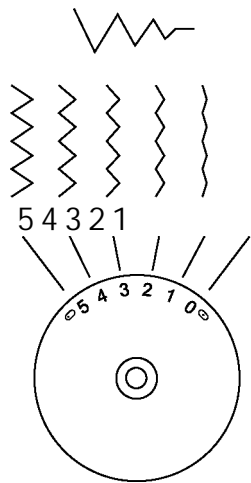
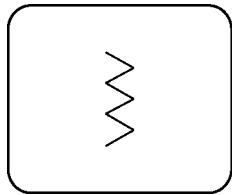

"5",
"0" "5",
"2,5", (55)
"0", "
"2,5"
"0" "1",
"

RU [REDACTED]

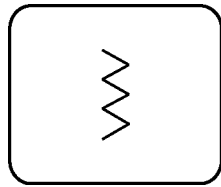

1.0 | ;10 0.5-4.0
| 1 03

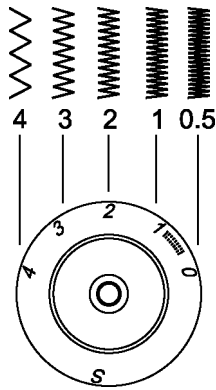
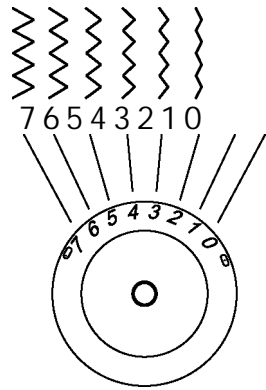

"7",
" " "7",
"4", (
65/8 /9)

" " " " "
"2,5"
" " "1",
" " "

55 | 65 | 80e | 90e

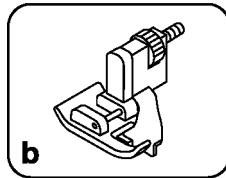
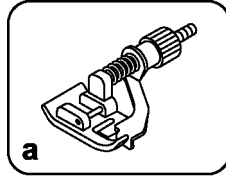
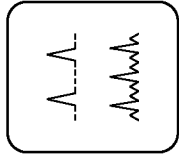

2.0 0 1.0-2.0 07
2!0 4 0[1]1[0-2!0
| 1 -11]13

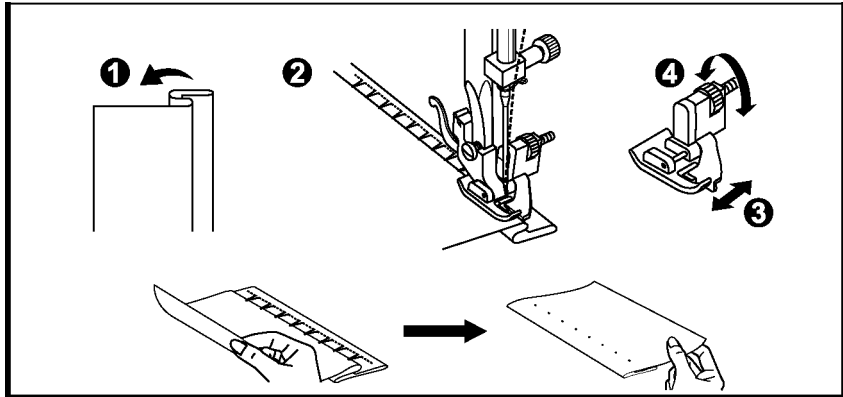

RU /
...
... (80 /90)
...
... (1)
... (2) (3)
... (4)
a. 55
b. 65/80 /90

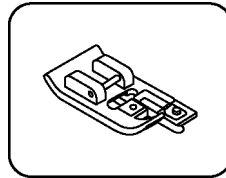
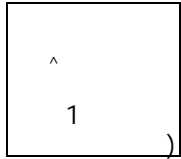

15-01111 1 5
| ||||| ^ 05

3-0 7-0 ||||| 51
|C| ZEZEZSQ06

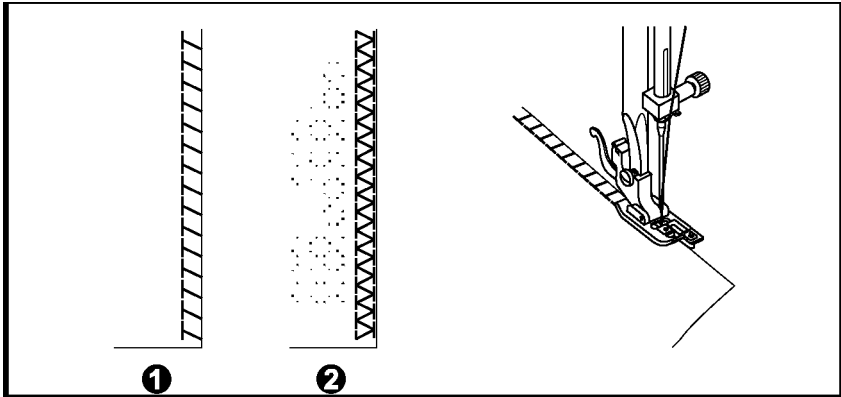

"4".
"3" "5". (55)
"8".
"3" "7".
(65/80 /90)

(1)
(2)

55 | 65 | 80e | 90e

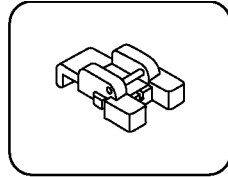
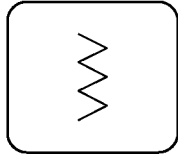

∩ ^
1!0 7!0| 0!5-4 0
| | MM 03

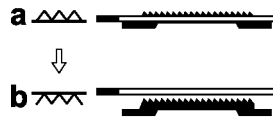

1

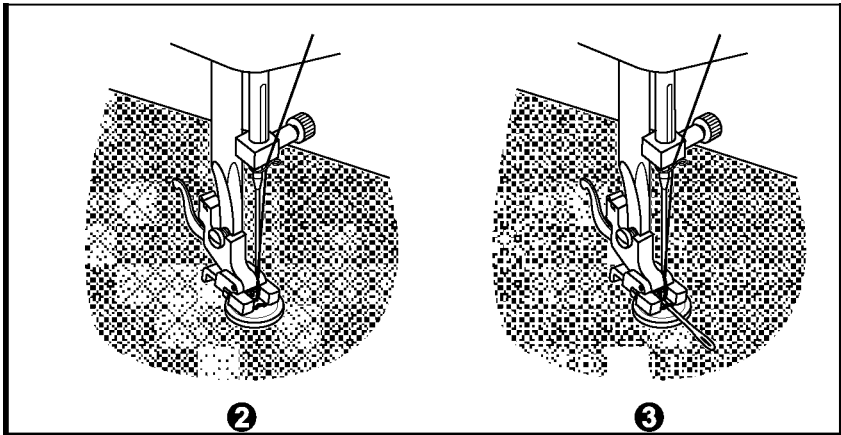

2

3

(1)

"3" "7" ("3" "5" (55)
65/8 /9)

1

(3).

(2).

(3).



2134
?]".

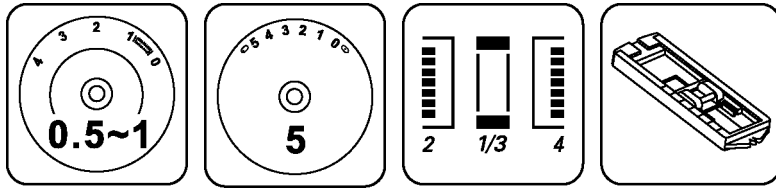

- 1.
- 2.
- 3.

0,3

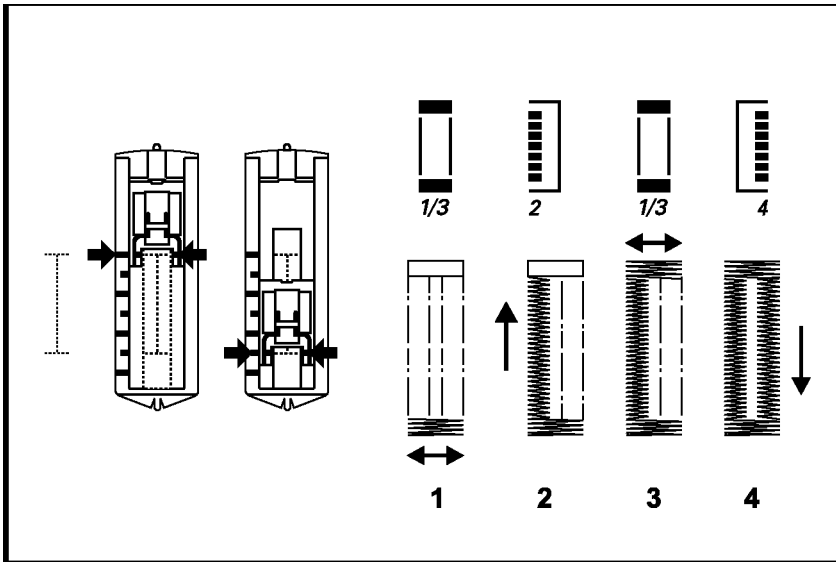

17,

"0.5-

1 3 ()

-
-
-
-

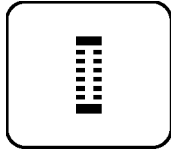

3.017^0] 0.5-1.0
& 01]11!!!!!!1 01

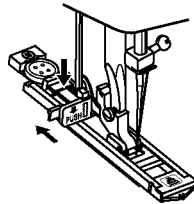
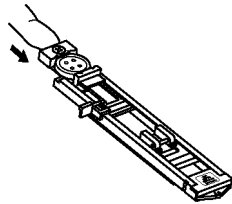
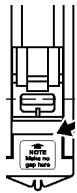

3
4
||
1

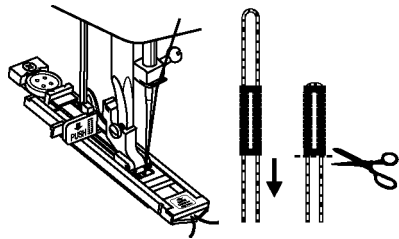
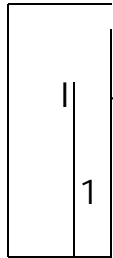

- 1.
- 2.
- 3.
- 4.
- 5.
- 6.
- 7.
- 8.

" "

() ()

()

()

()

()

()

()

- 1.
- 2.
- 3.
- 4.

" "

RU



" | "

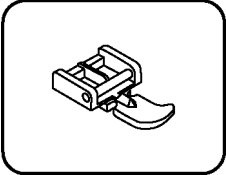
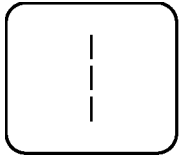

0.0S7^0 2 5-4.0
1 11-1-02

"2.5" "4" (
).

" "

" "

(1)

" "

(2)

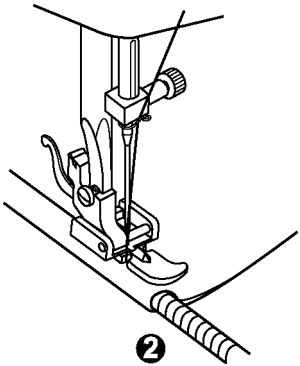
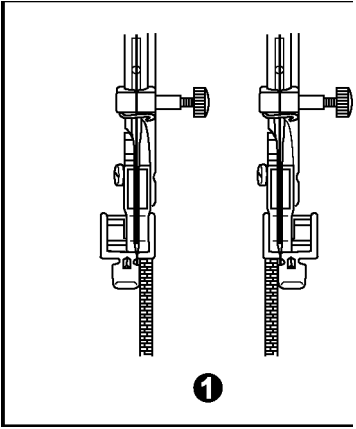

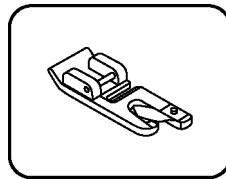
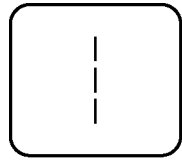

0.057 01 2 5-4.0
1 11-1-02

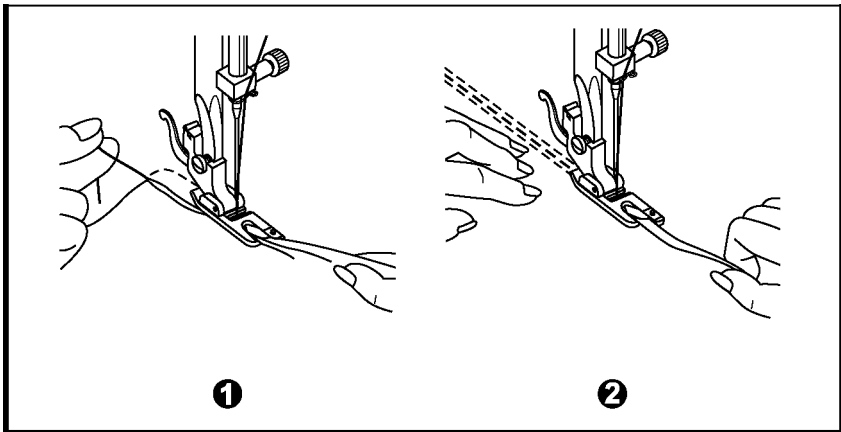

"2.5" "4".

" "

4-5

3

(1)

(2)

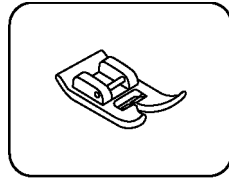
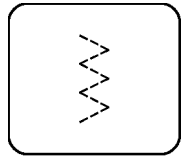

3!0 7!0||0 5-1['5
| ||||/^^\[]04

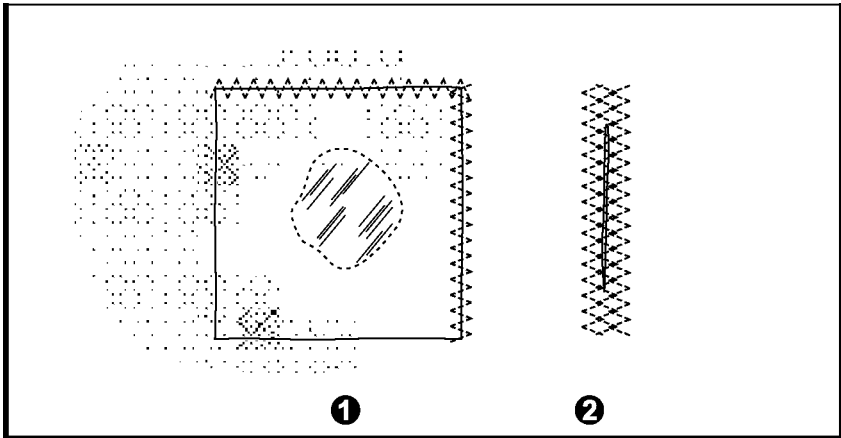

"1" "2".
"5". (55) "3"
"7". (65/80 /90) "3"

(1)

5 .(2) 3

RU [REDACTED]

: (1)

"I".

"4".
(55)

"8". (65/80 /90)

"0".

: (2)

"I".

(55)

"4",
"3" "5".

(65/80 /90)

"8",
"3" "7".

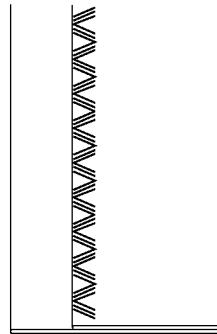
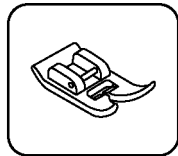
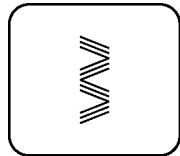
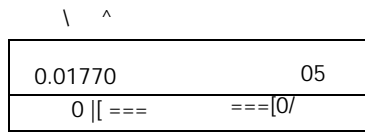
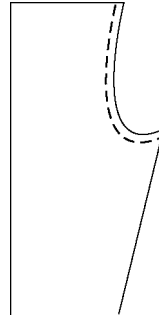
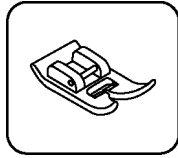
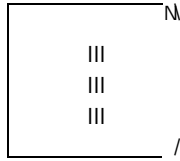

O

55 | 65 | 80e | 90e

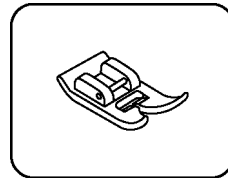
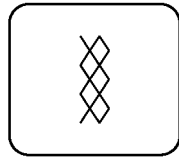

∨ ^

3.017^0
10

03
04

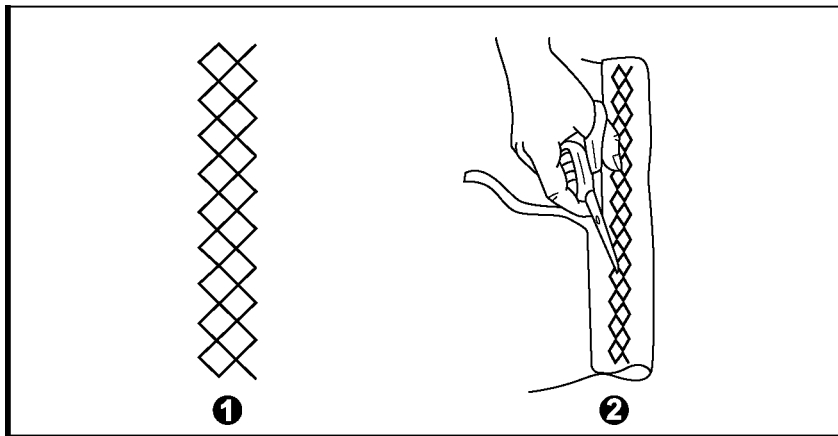

RU

"4":
"4" "5". (55)

"8":
"4" "7". (65/80 /90)

. (1)

. (2)

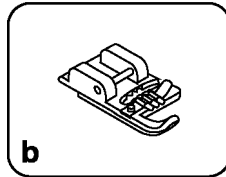
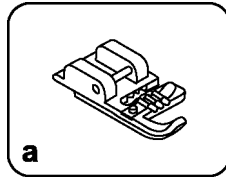
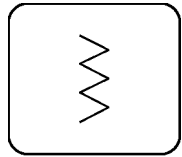

1.0 7?0 0.5-4.0
i0 / 03

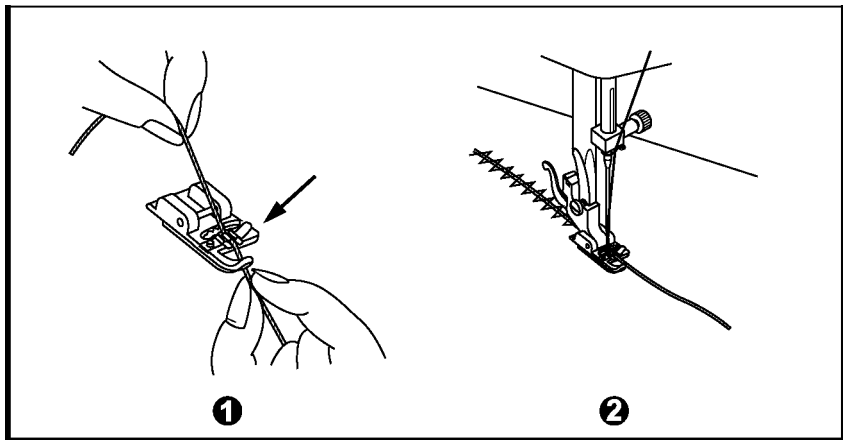

"1".

"1" "4".

"3" "5". (55)

"3" "7". (65/80 /90)

. (1/2)

- a. 55
- b. 65/80 /90

55 | 65 | 80e | 90e

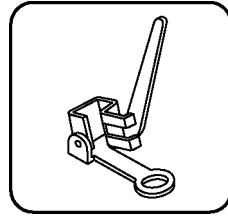
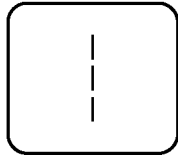

0 0-7 0 2 5-4 0

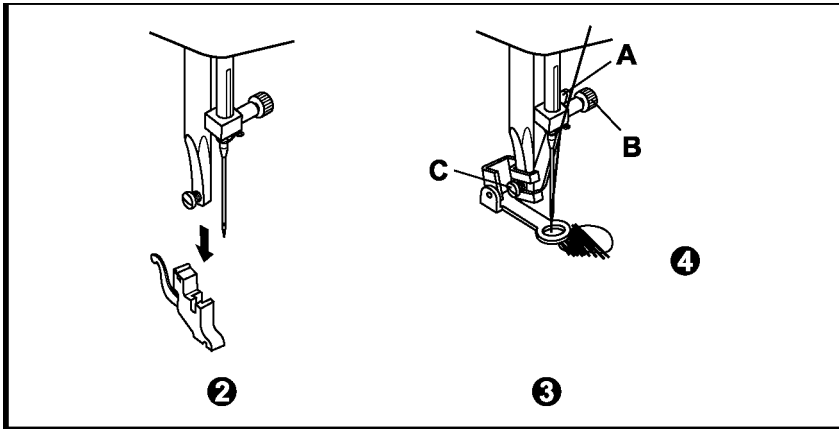

RU

?!?
!.
" "
" "

(1)

(2)

(. .28). ()

().

(). (3)

(. (4). :



3.0-7.0 1.0-2.0
C 0 0 A..A.. 05

3.0-7.0 1.0-2.0
C 0 0 V/V/V 06

3.0-7.0 1.0-2.0
C 0 0 v^v^v^ 08

3.0-7.0 0.5-1.0
C 0 0 ^^^^ 12

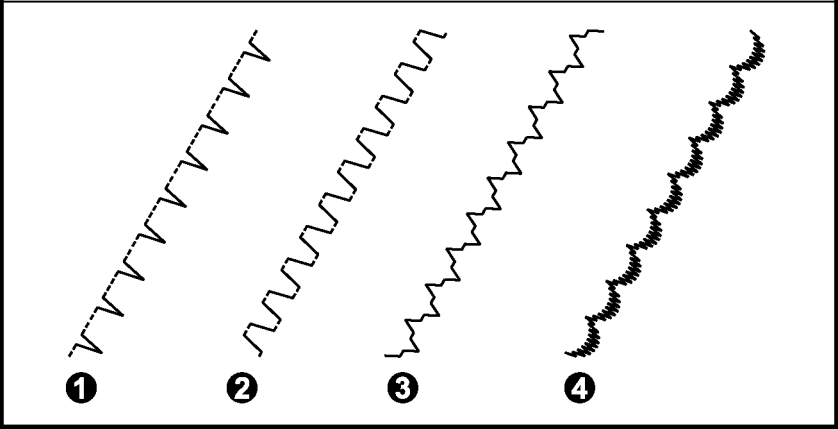
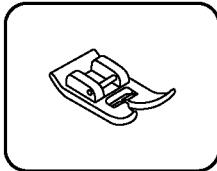
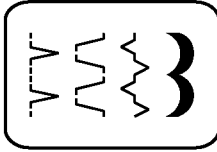

???

(55)

(65/80 /90)

?5?

?3? ?7?

(1)

" ^ "

(2)

" ^ "

(3)

" ^ "

(4)

" ^ "



RU [Solid black box]

55 | 65 | 80e | 90e

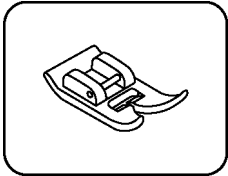
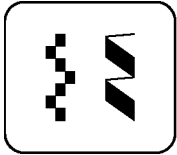

3.0|7 0 0.5-1.0

3.017 0 0.5-1.0 *viv* 10

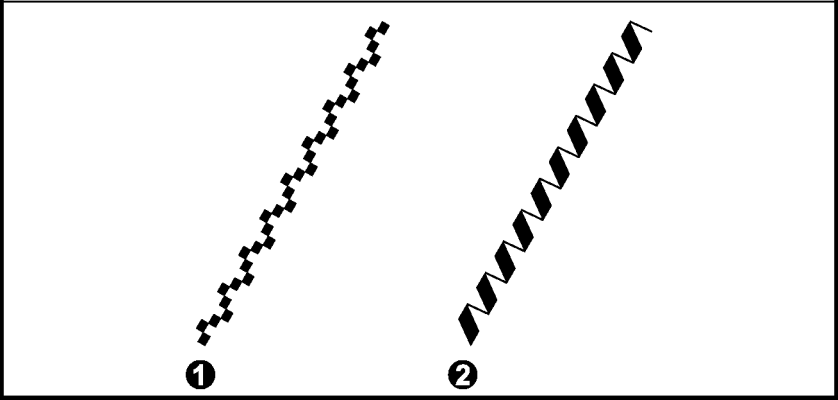

"0.5" "-1".

"3" "7". (65/80 /90)

"3" "5". (55)

(1)

"?"

(65/80 /90)

(2)

" "

(80 /90)

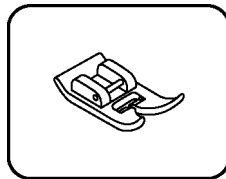
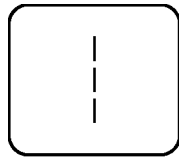

0[>0-7:0||2 5-4 0
| | | --^ 02

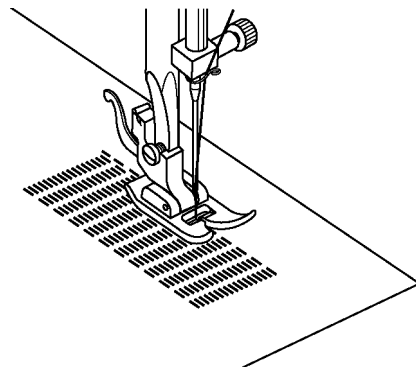

" | "

RU [REDACTED]

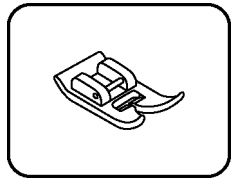

0 0-7 0 2 5-4 0

[C] F ---^[]02

"I".

6)

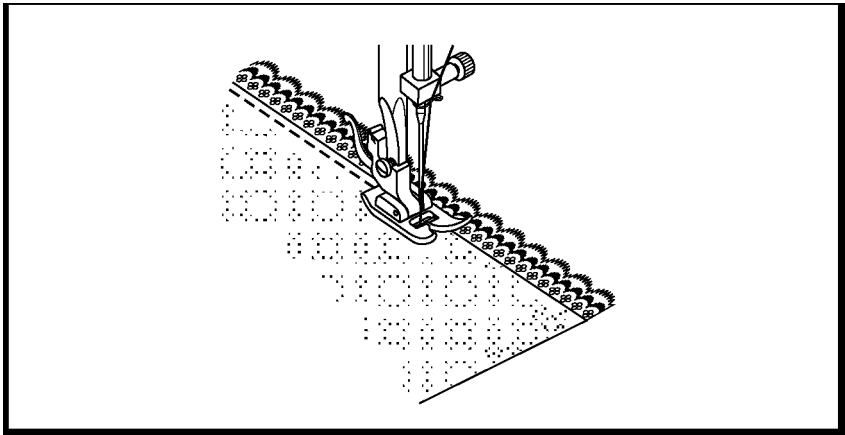

55 | 65 | 80e | 90e

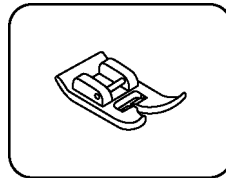
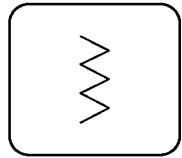

∩ ^
1.017^0 0.54.0
10 ∩ ∩ ∩ 03

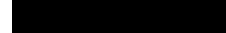

"1"

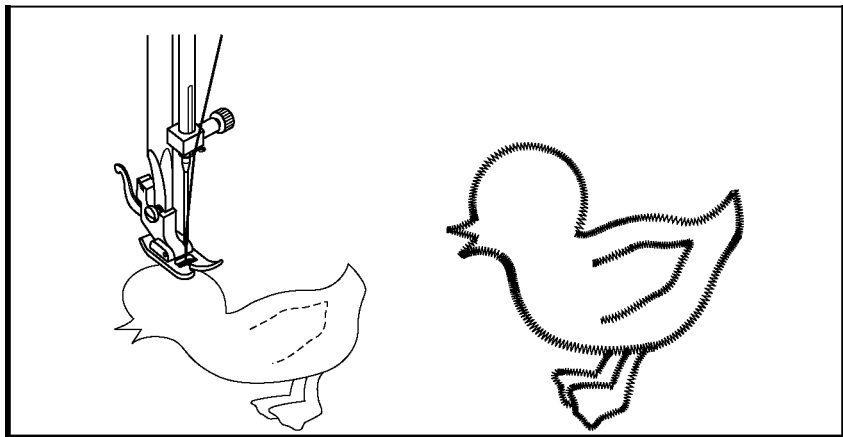

RU [REDACTED]

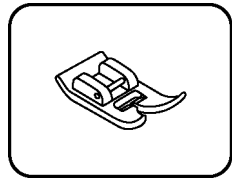
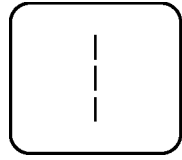

0 0-7 0 2 5-4 0
| | 1 ---- 02

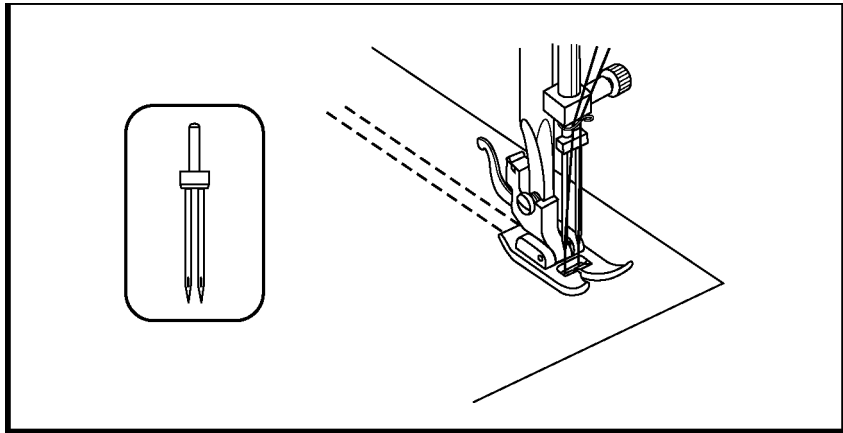

"1".

" " "2.5".

"2.5"

.(55)

" " "4".

"4"

.(65/8 /9)

RU



55 | 65 | 80e | 90e

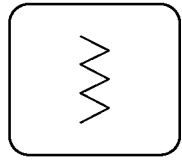

W ^

1.017^0 0.5 4.0
10  03

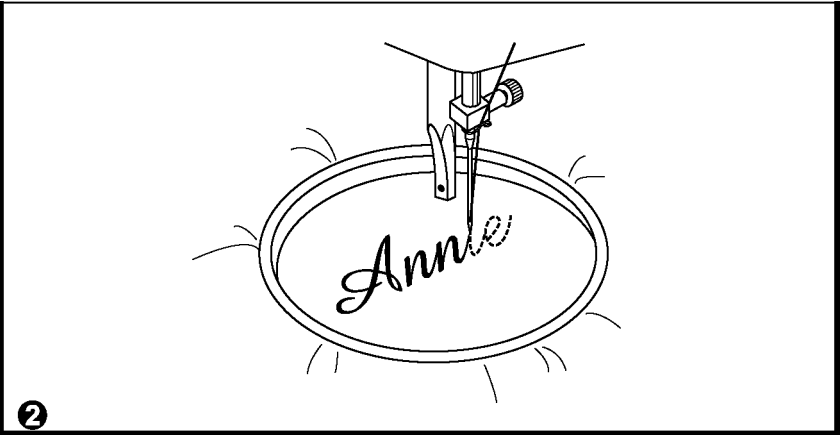

"I"

(1)

3.0S750 0.0-4.0
i 14

0 7. "0 || 0?0-4 0
| | | | | 015

3.0S7^0.0010-4.0
11 16

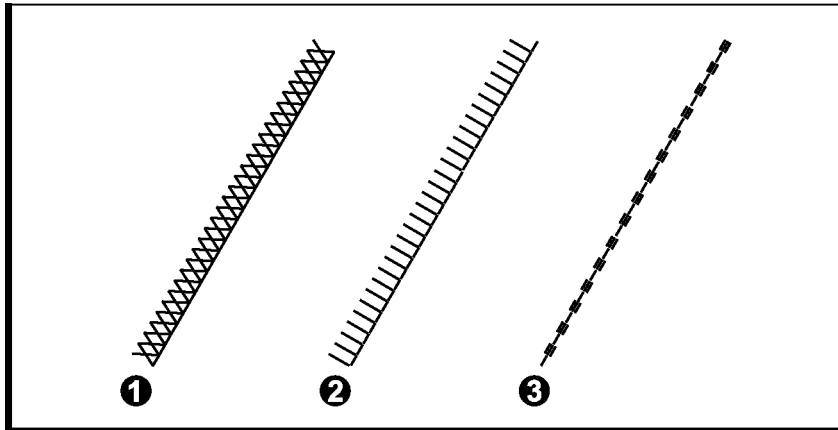
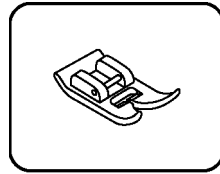
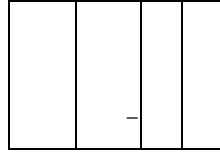

"4". "3"

"7". (65/80 /90)
(1)

(65/80 /90)
(2)

(80 /90)
/ (3).

(80 /90)

()

55 | 65 | 80e | 90e

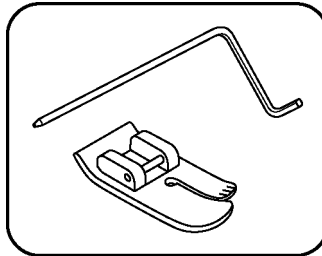
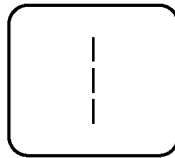

0.05770 2 5-4.0
10 11-1- 02

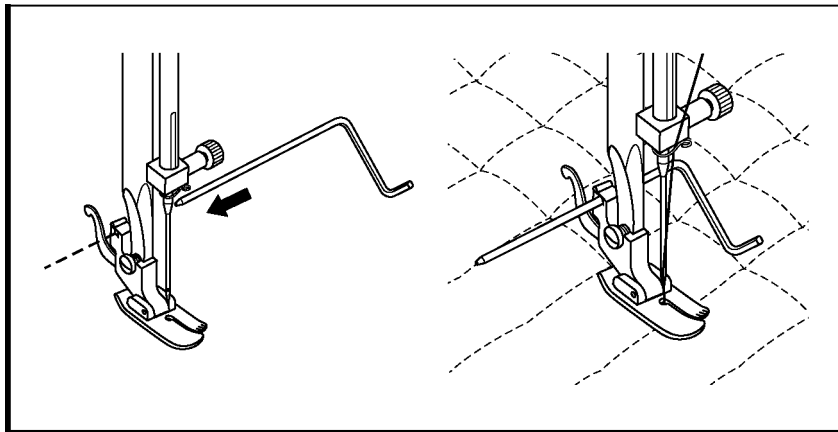

"2.5" "4".

"1".

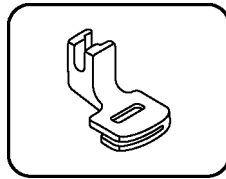
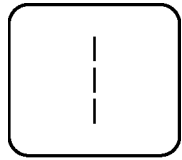

0.057¹⁰ 2.5-4.0
1 1 11-1-02



1. "1".
2. "2.5" "4".
- 3.
4. ("2").
- 5.

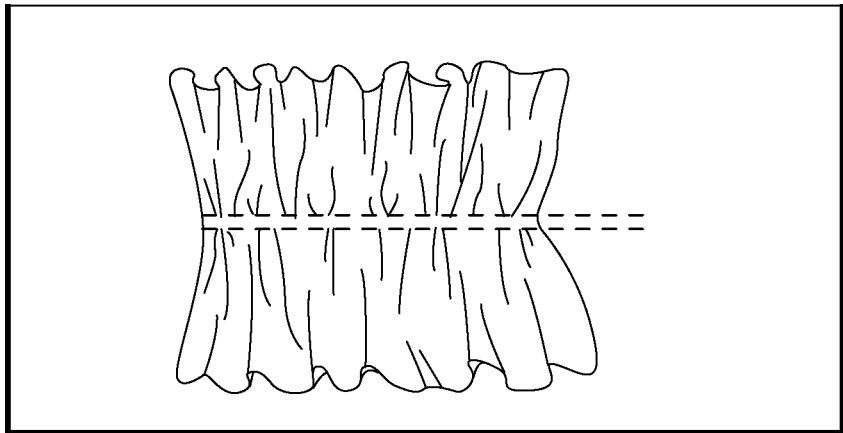



RU

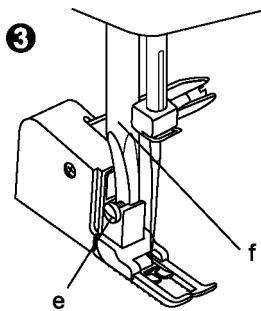
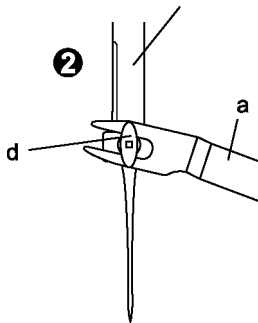
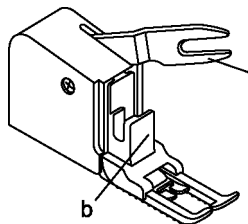

- 1.
2. (3) (. 28).
3.
 - i)
 - ii) . (2)
 - iii)
 - iv)
- 4.
- 5.



RU



55 65 80e 90e

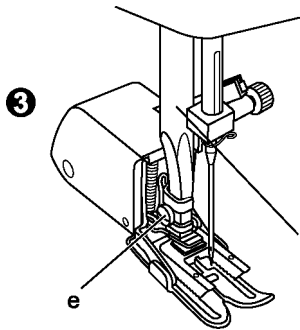
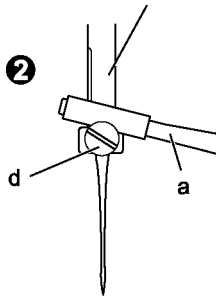
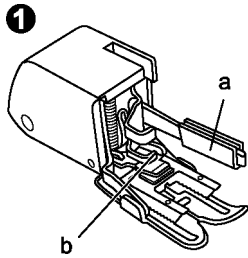

- 1.
2. (3) (. . . 28).
3.
 - i)
 - ii) . (2)
 - iii)
 - iv)
- 4.
- 5.



RU

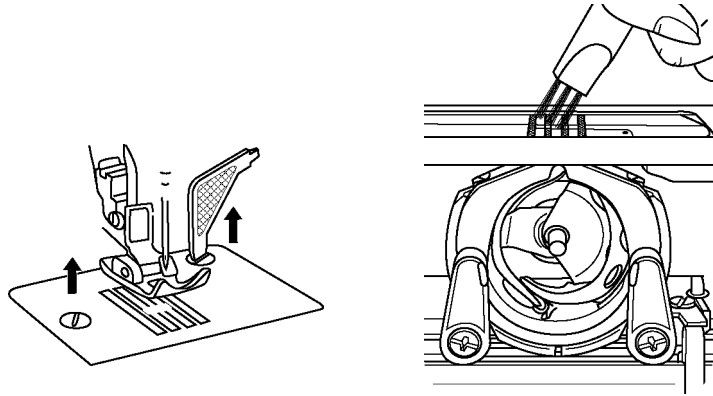

O

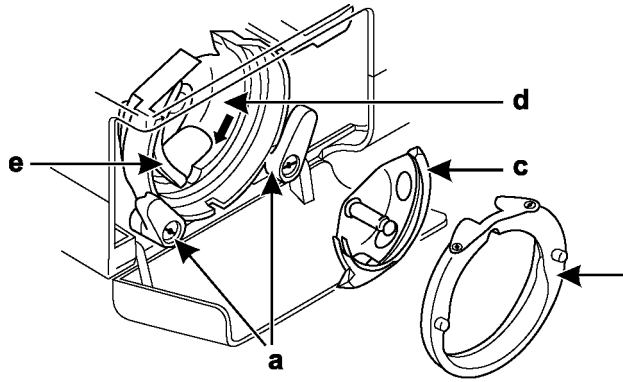

3

" "

(1)

(3).

() () (2), ()

() () 1-2

() ()

() ()

!

!



RU [redacted]

55 | 65 | 80e | 90e

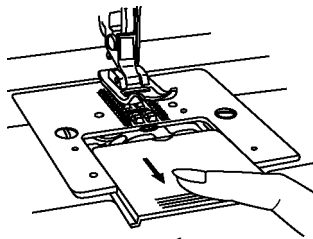

-1

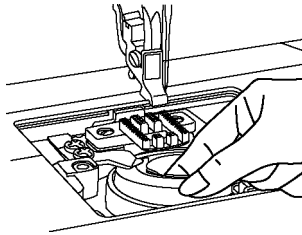

-2

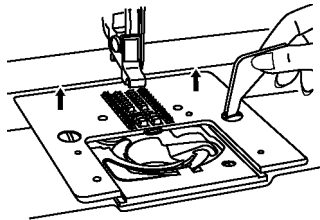

A-2

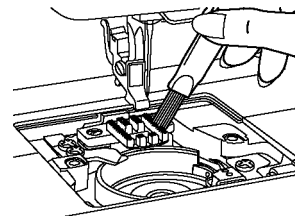

B-3

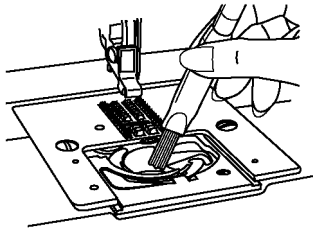

B-1

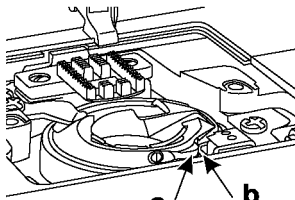

B-4

(-1),
(-2),
(-3),
() () (-4),
(-1)

55 | 65 | 80e | 90e

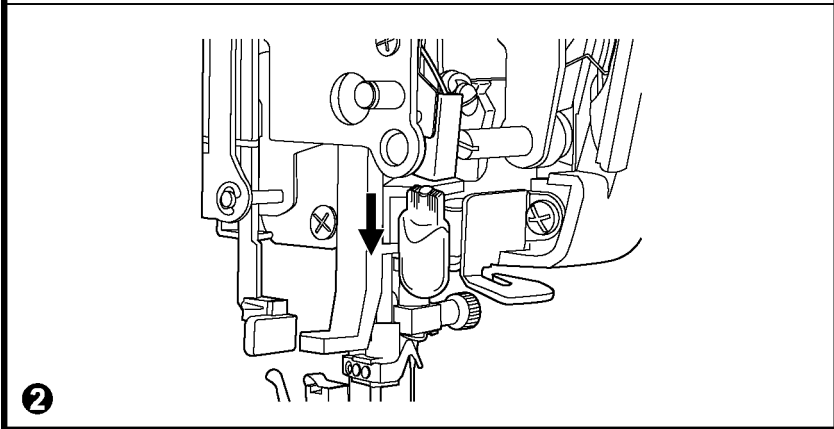
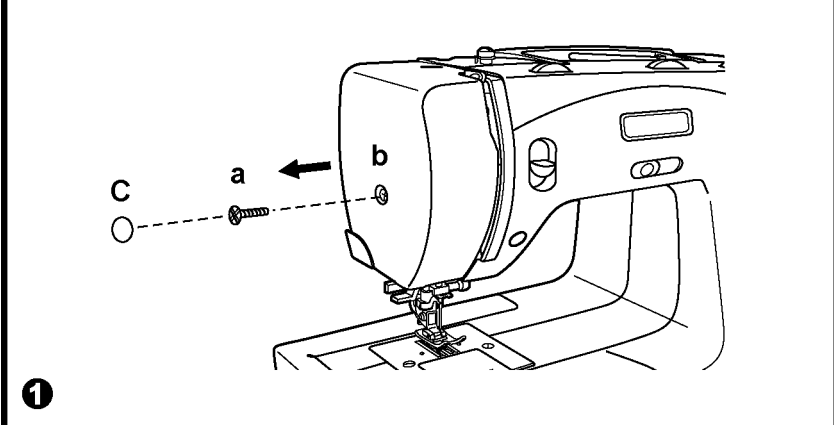

:"

(), (), (),

() (1)

:

(2)

1 /12 10 /

5 , 22 /24 - 12 /

5 .



1.
2.
3.
4.
5.
6.

1.
2.
3.
4.

1.
2.
3.
4.

1.
2.
3.
4.

1.
2.
3.

1.
2.
3.

1.
2.
3.
4.

1.

1.
2.
3.
4.

5.
6.

1.
2.
3.
4.

1.
2.
3.
4.

1.
2.
3.
4.

1.
2.
3.

1.
2.
3.

1.
2.
3.
4.

1.

? - - ?



1

()

3
30163.0.-95).

(

(.)

6

()

7

8

9. ()

9.1.

9.2.

9.3.

9.4.

9.5.

9.6.

10.

()
()

11.

12.

()

13.

14.

15.

16.

()

17.

()

RU [REDACTED]

	55	65	80	90
:	8,7	10	10	10
()	7,6	9,2	9,2	9,2
:	.54	.54	.54	.54
:	.58	.58	.58	.58
:	II	II	II	II
:	220/ 240	220/ 240	220/ 240	220/ 240
/	120/ 800	120/ 800	120/ 800	120/ 800
:	/ 70	/ 70	/ 80	/ 80
:	80 %	80 %	80 %	80 %
:				
:				
:	.122			
:	10	10	10	10
:	.14	.16	.16	.16

:

(,)

RU

				48		
	40		46	10, 12		96
			76			116
			50	1		92
					70	112
32	, 34					, 72
"	"				66	, 68
	84	118,	120			
	104			132		
	20		94	14, 16		54
			86			134
	44			9		
58	, 90			18, 20	122, 124,	126
			110	78		
				114		88
	100		28	22, 24		
	108			/		36
	26			74		128
			30			
			42			
	60	Q			98	102
	106				52	
			50		26	
			80, 82			
	38					
			62, 64			