

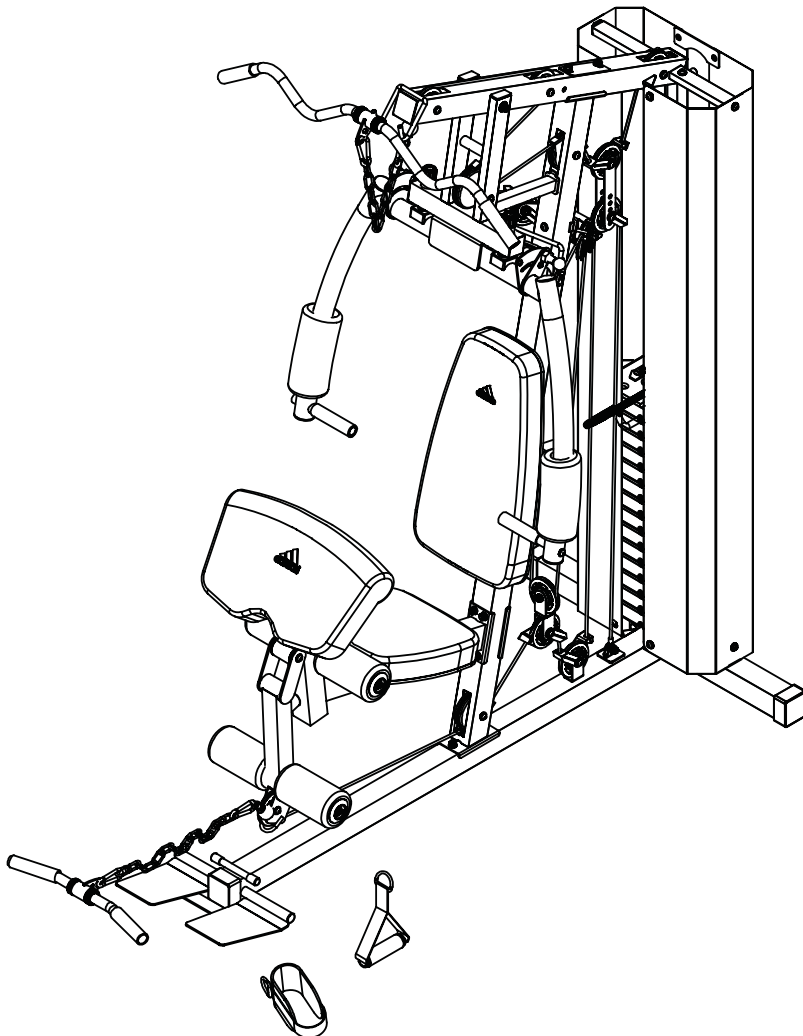

HOME GYM ADBE-10250

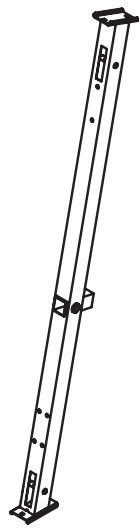



① × 1



⑤ × 2

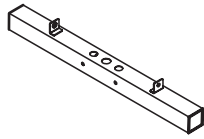

② × 1

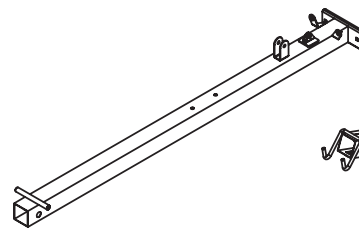

③ × 1

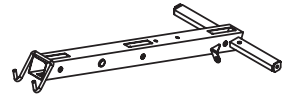

④ × 1

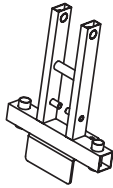

⑥ × 1



⑦ × 1



⑧ × 1

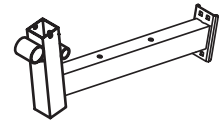

⑨ × 1

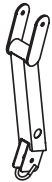

⑩ × 1



⑪ × 1



⑫ × 1



⑬ × 1

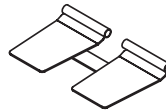

⑭ × 1



⑮ × 1

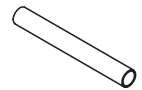

⑯ × 2



⑰ × 1

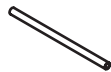

⑱ × 1



⑲ × 1



⑳ × 1



㉑ × 1

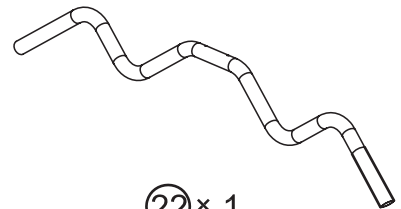

㉒ × 1

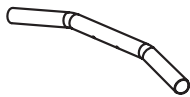

㉓ × 1



㉕ × 2

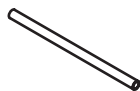

㉖ × 2



㉗ × 2



㉘ × 2



㉙ × 1



⑳ × 1

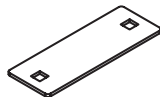

㉑ × 2

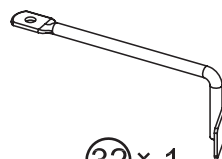

㉒ × 1

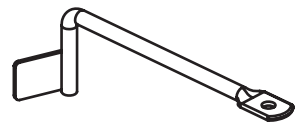

㉓ × 1

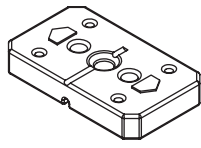

34 x 1

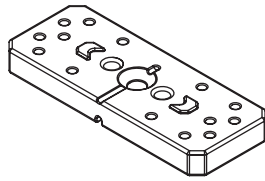

35 x 13



36 x 1



37 x 1



38 x 1



39 x 1

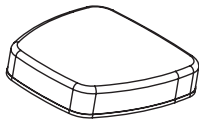

40 x 1

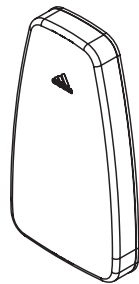

41 x 1

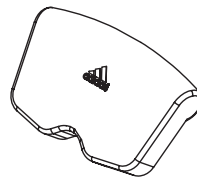

42 x 1

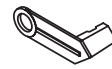

43 x 14



44 x 14



45 x 1



46 x 1



48 x 4

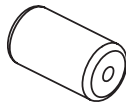

49 x 4



50 x 2

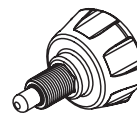

51 x 2



52 x 2



55 x 2



58 x 2



59 x 2



62 x 11



63 x 3



65 x 2



76 x 2

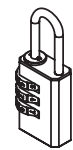

78 x 1

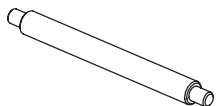

79 x 1

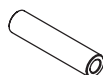

80 x 1



81 x 4

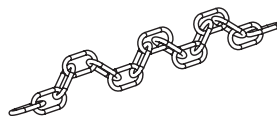

82 x 1

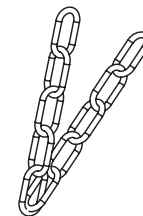

83 x 1

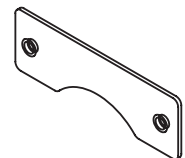

105 x 2

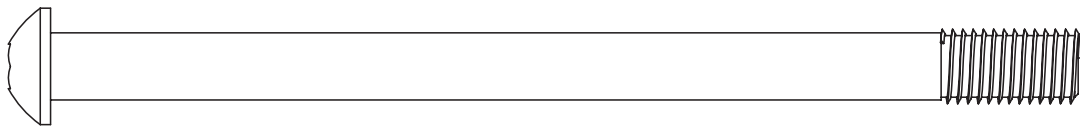

86 × 1



85 × 10

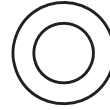

101 × 14

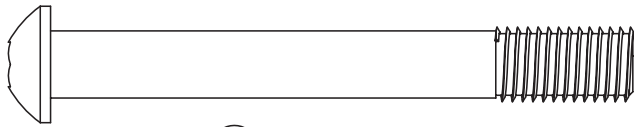

87 × 5

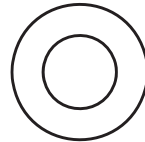

100 × 73

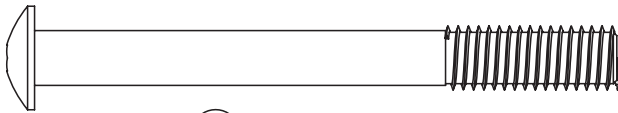

94 × 2

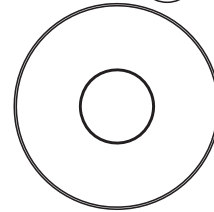

61 × 2

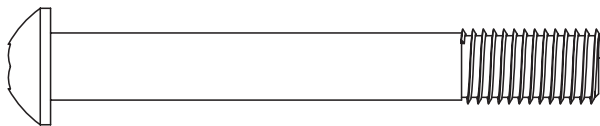

88 × 2

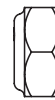

103 × 4

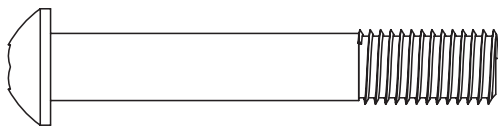

89 × 2

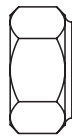

102 × 30

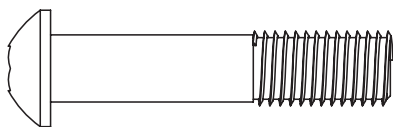

90 × 7

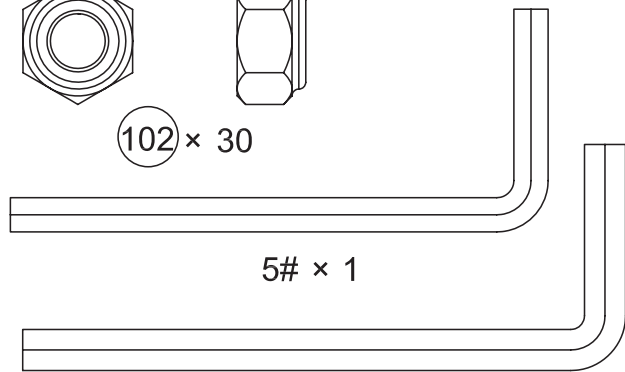

5# × 1

6# × 2

mm



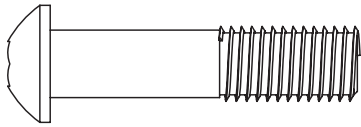

98 × 1

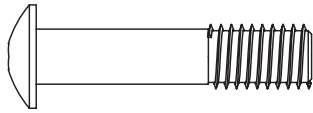

95 × 2

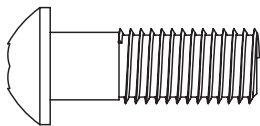

91 × 1

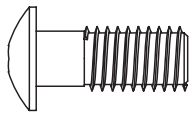

96 × 2

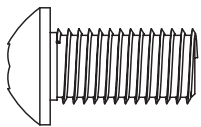

92 × 10

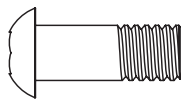

97 × 4

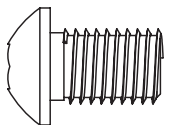

93 × 14

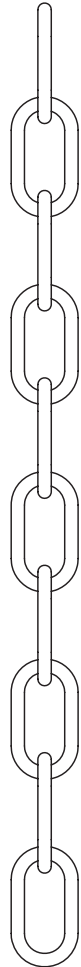

83 × 1

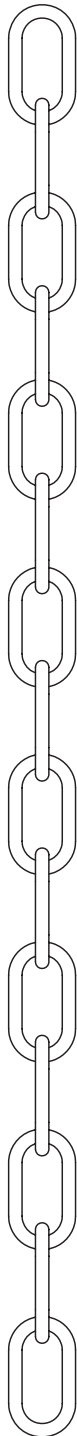

82 × 1

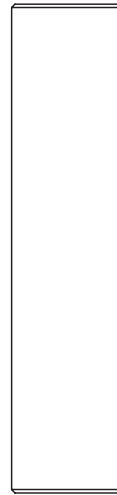

80 × 1







81 × 4

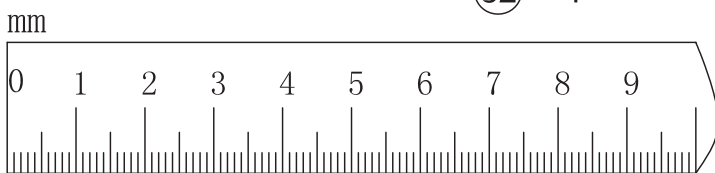
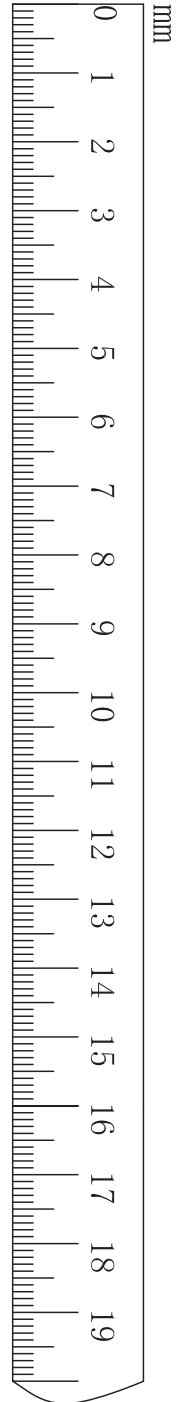



79 × 1

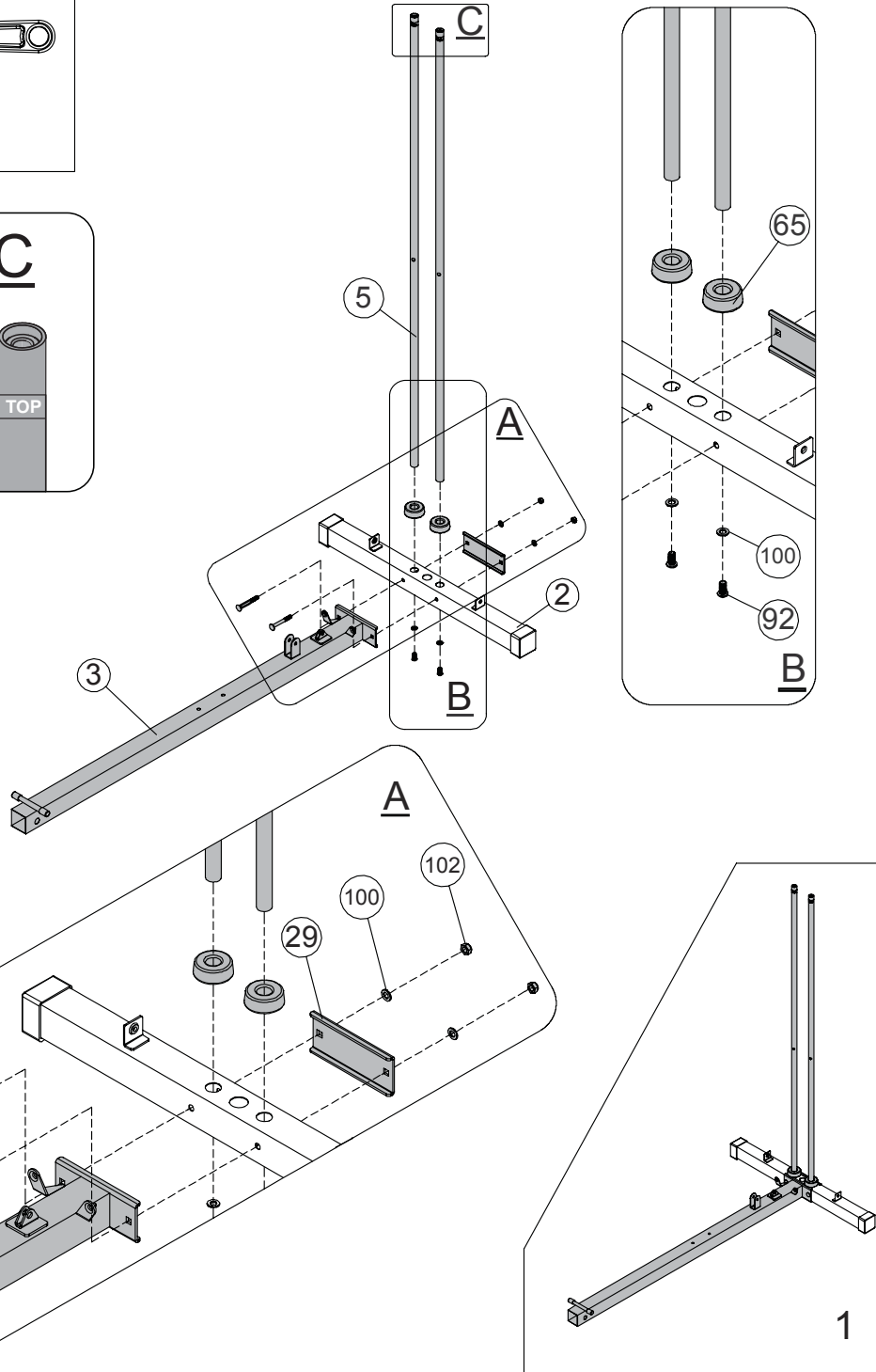
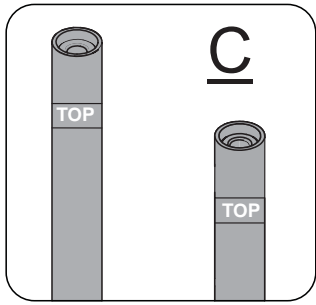
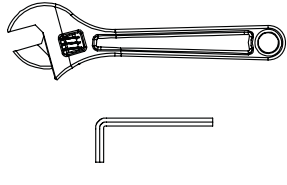

- | | | | |
|-------|---|-----|-----------|
| (85) |  | × 2 | M10×85mm |
| (92) |  | × 2 | M10×20mm |
| (102) |  | × 2 | M10 |
| (100) |  | × 4 | Φ20×Φ10.5 |

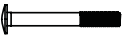



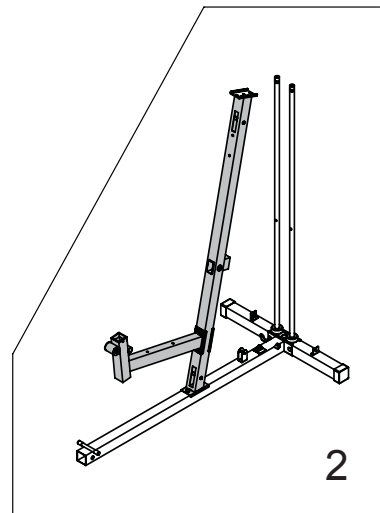
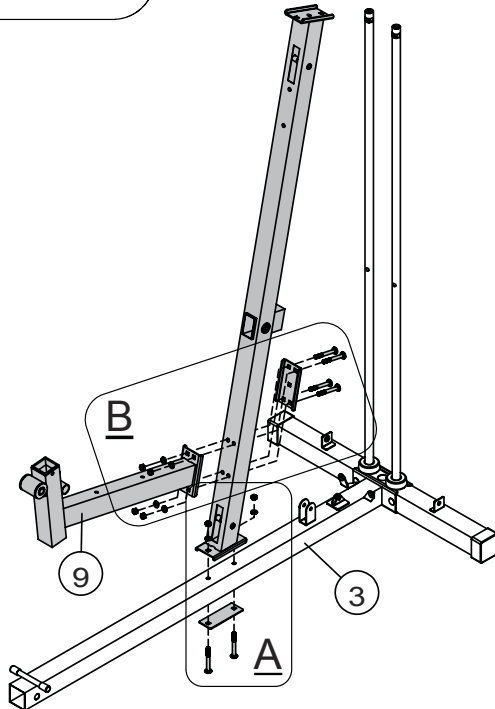
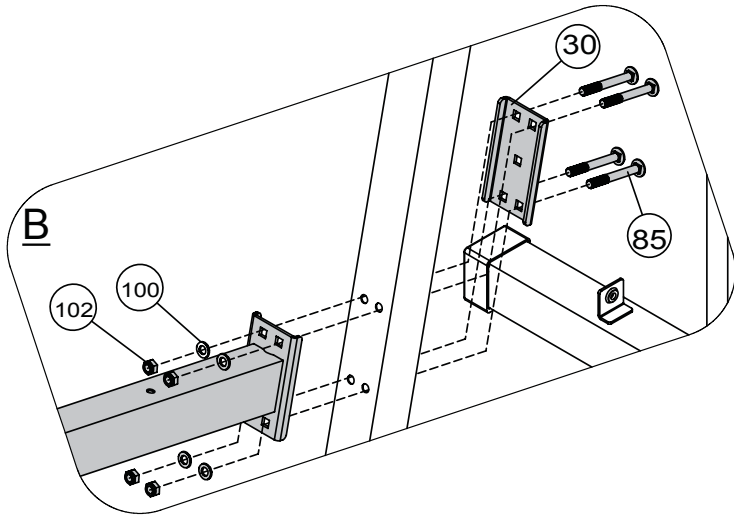
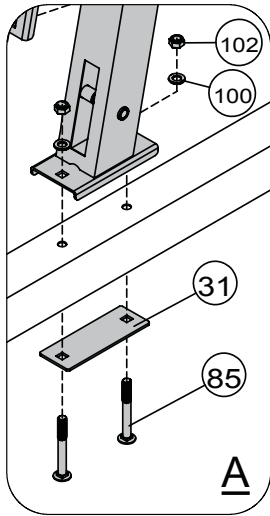

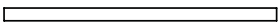

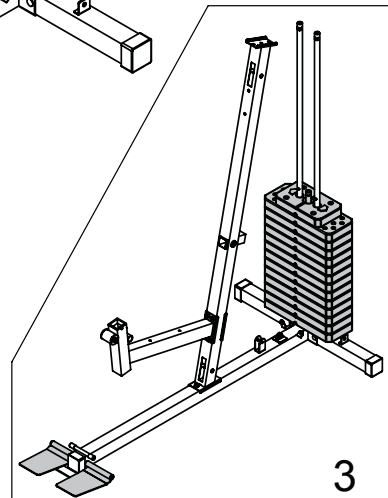
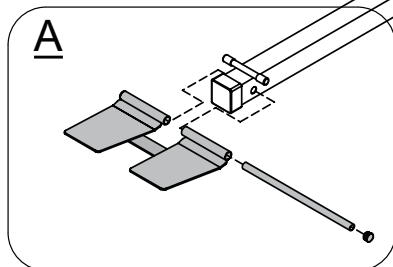
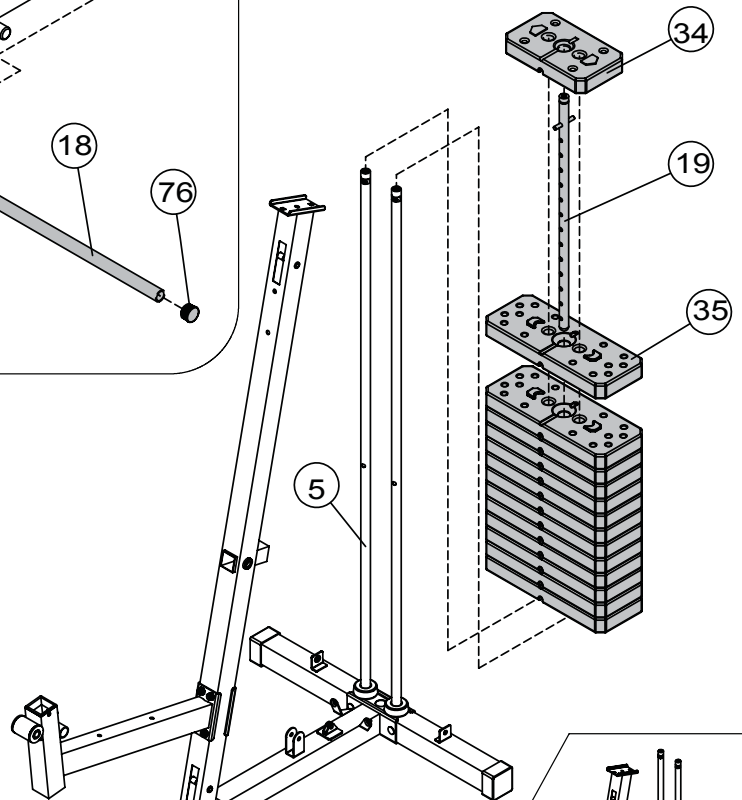
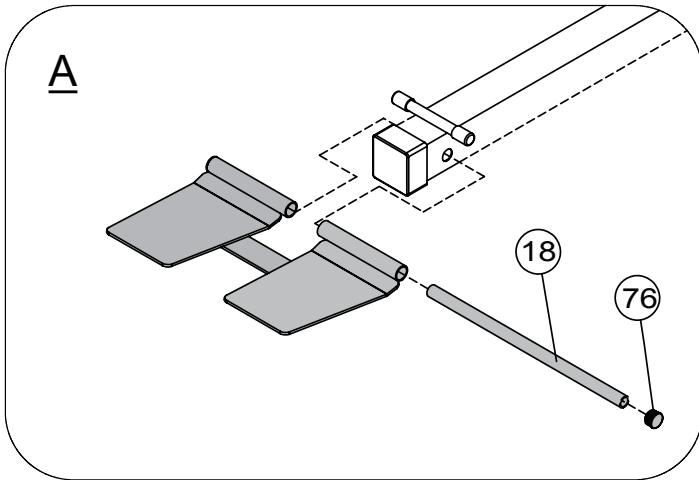
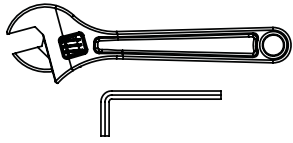
- | | | | |
|-----|---|-----|-----------|
| 85 |  | × 6 | M10×85mm |
| 102 |  | × 6 | M10 |
| 100 |  | × 6 | Φ20×Φ10.5 |

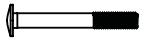





18  × 1 φ19×2×350

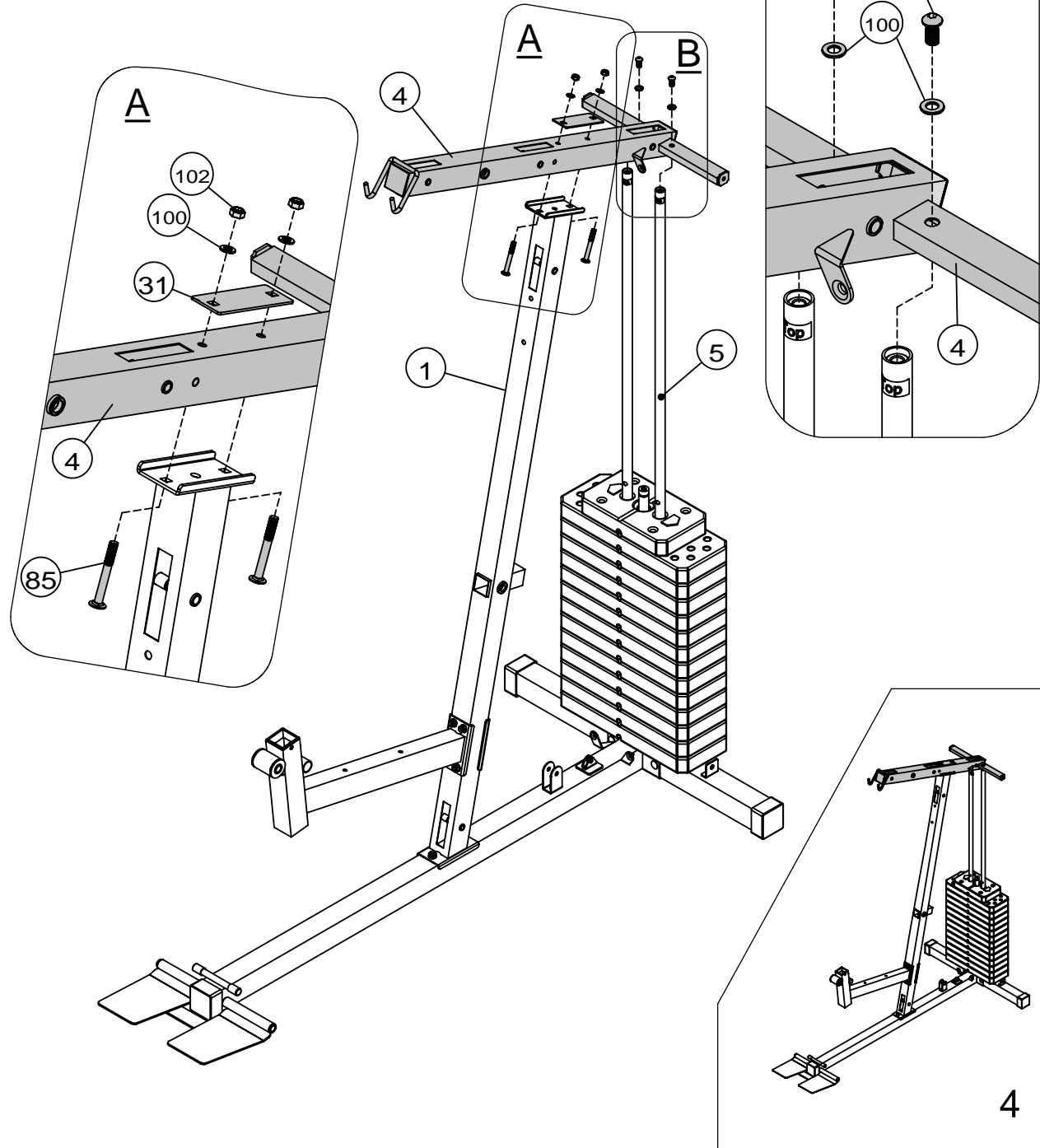
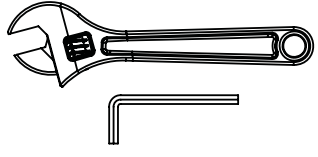

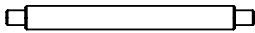
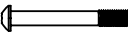
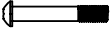

- 85  × 2 M10×85mm
- 92   × 2 M10×20mm
- 102   × 2 M10
- 100   × 4 Φ20×Φ10.5



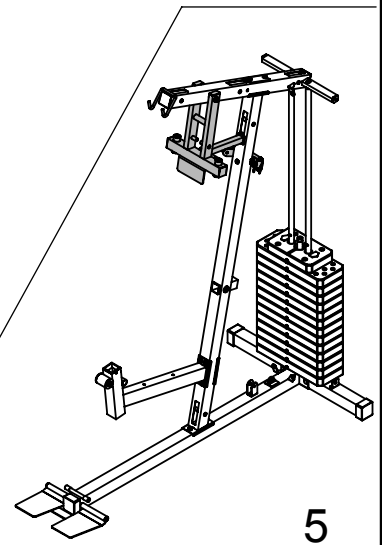
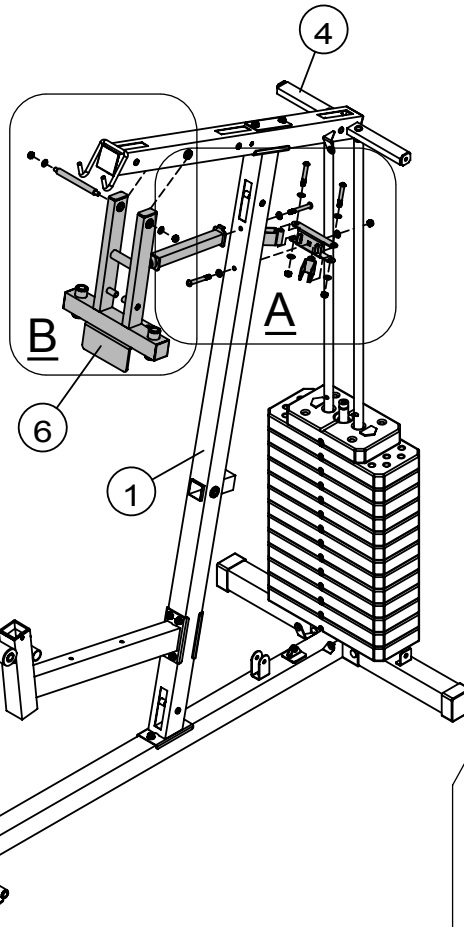
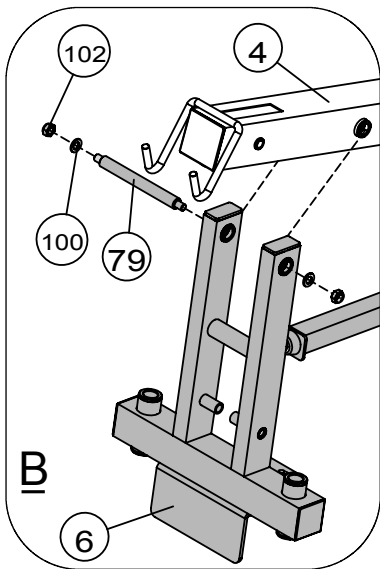
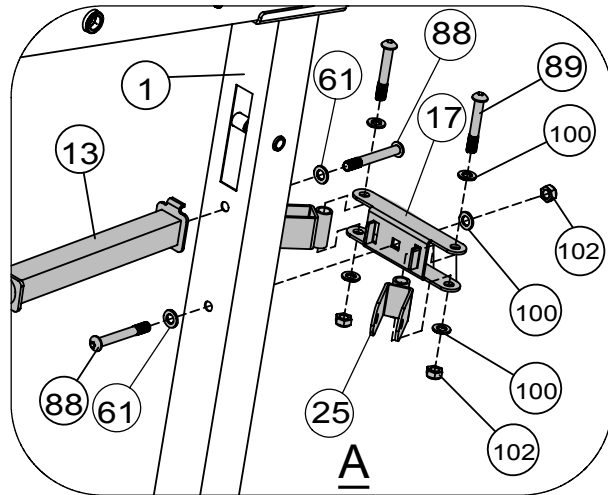
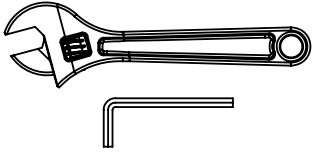

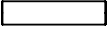

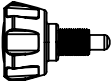

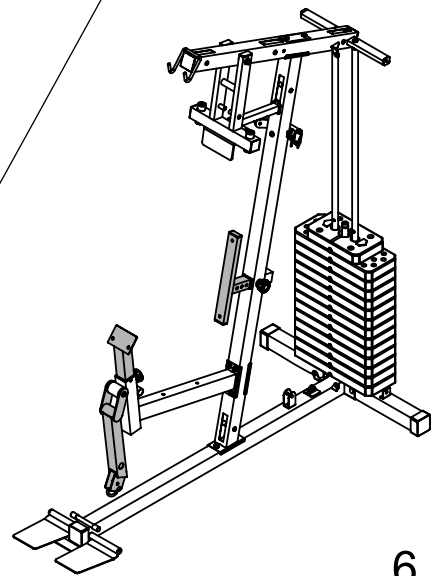
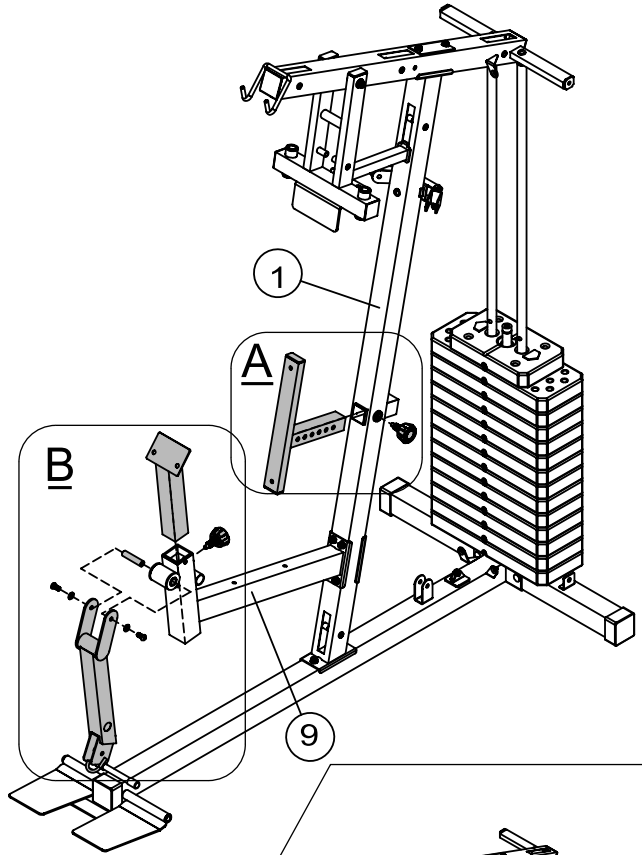
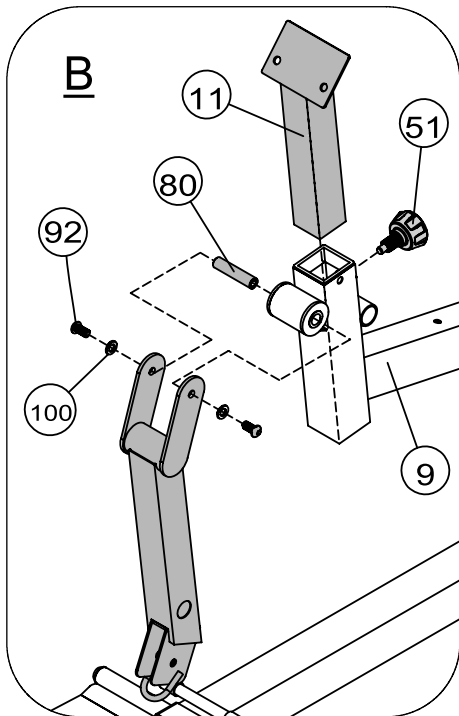
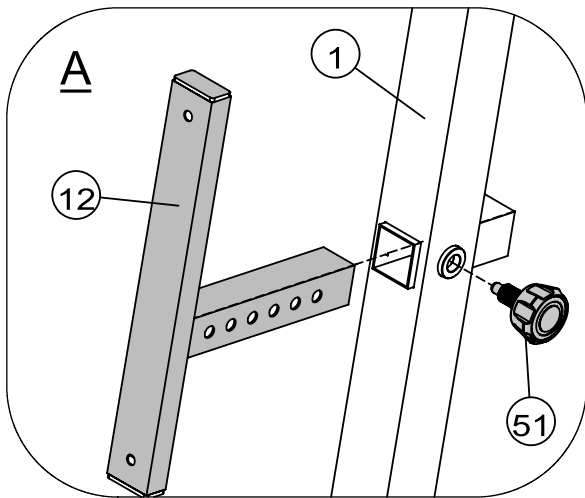
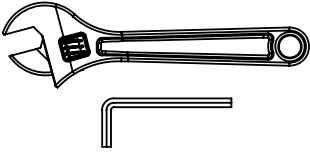
79		× 1	M10×φ16×169
88		× 2	M10×80mm
89		× 2	M10×65mm
102		× 5	M10
100		× 7	Φ20×Φ10.5
61		× 2	Φ30×Φ10.5×2.5







80		× 1	M10×Φ16×71
92		× 2	M10×20mm
100		× 2	Φ20×Φ10.5
51		× 2	M18×Φ10

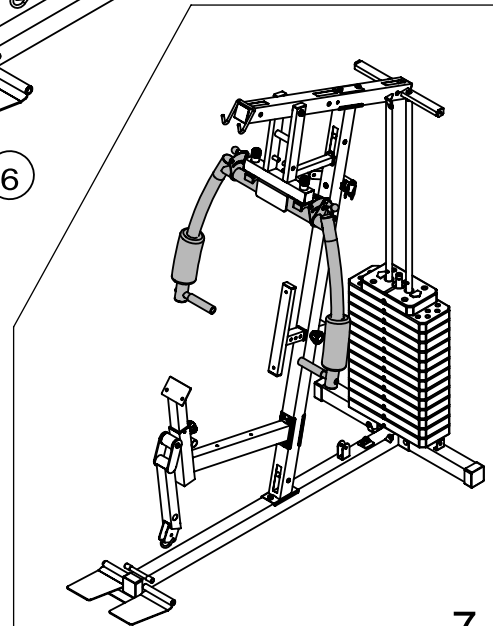
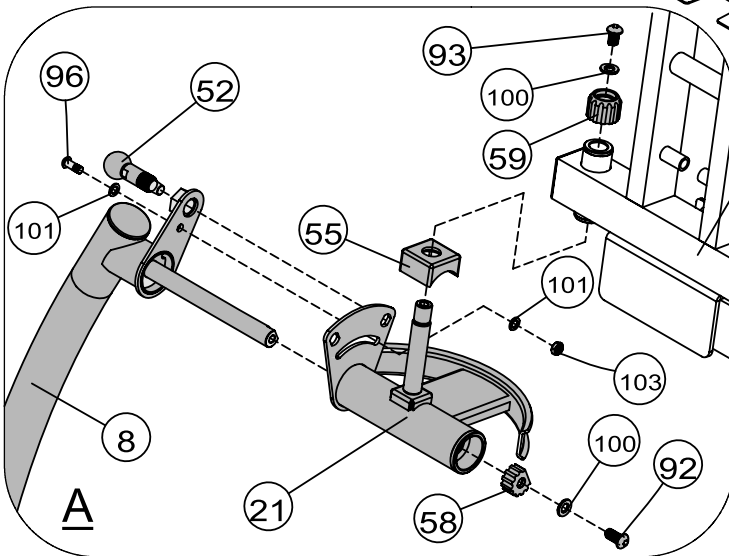
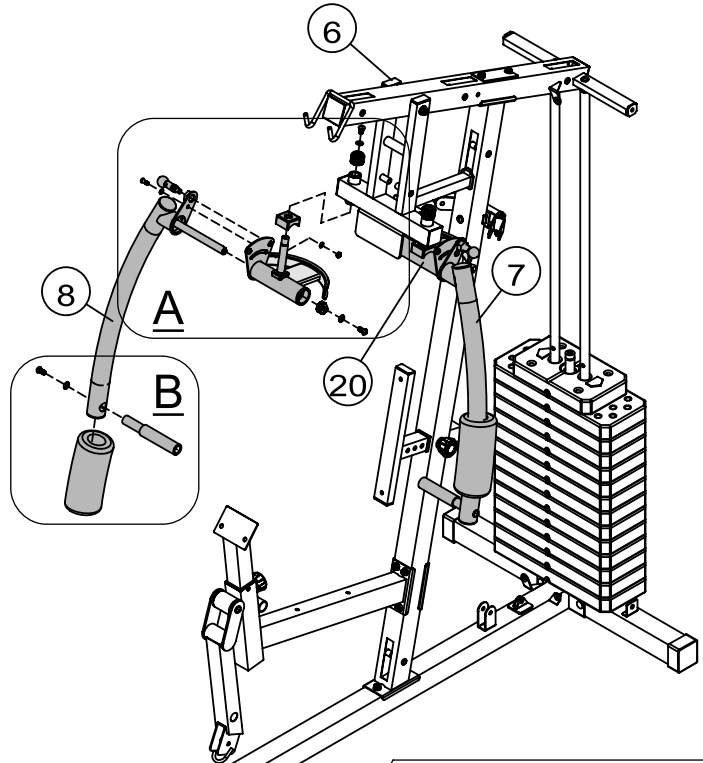
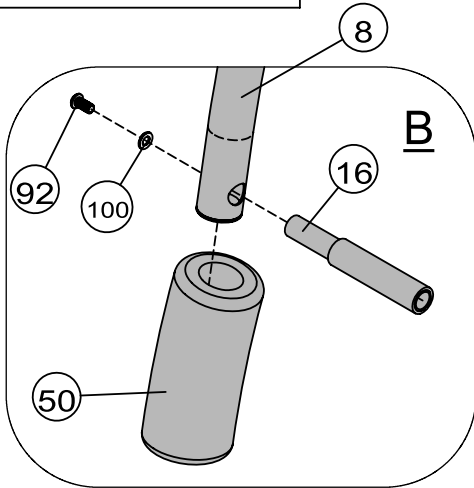
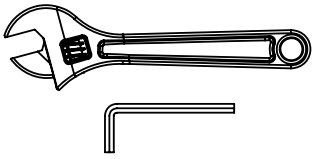

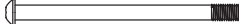
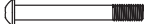
52		× 2	
92		× 4	M10×20mm
93		× 2	M10×16mm
96		× 2	M8×22mm
100		× 6	Φ20×Φ10.5
101		× 4	Φ16×Φ8.4
103		× 2	M8

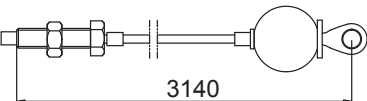

86		× 1	M10×150mm
87		× 4	M10×85mm
90		× 1	M10×50mm
100		× 14	Φ20×Φ10.5
102		× 6	M10
37		× 1	

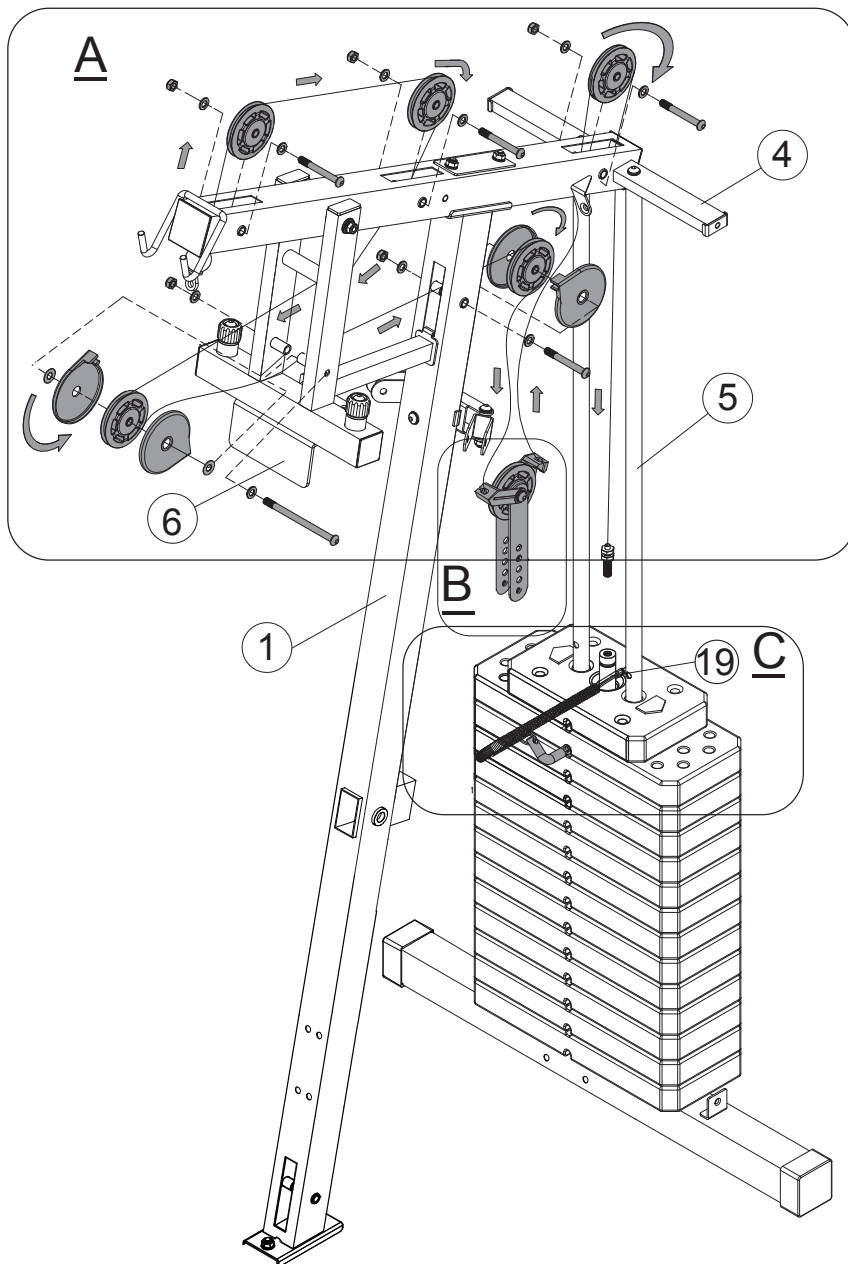
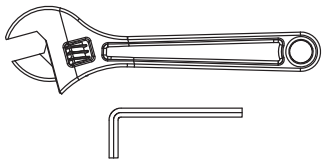

8

8-A

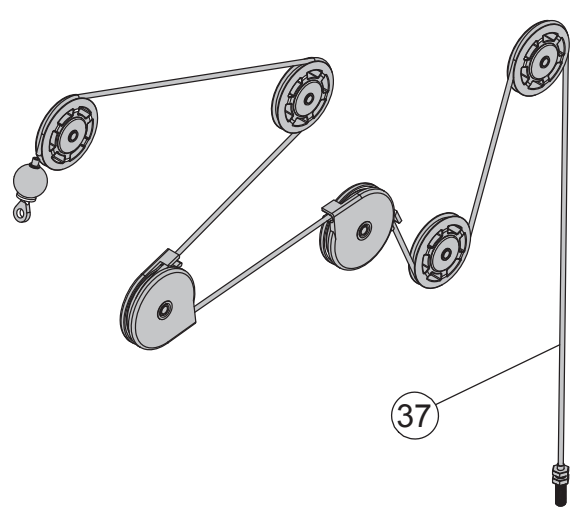
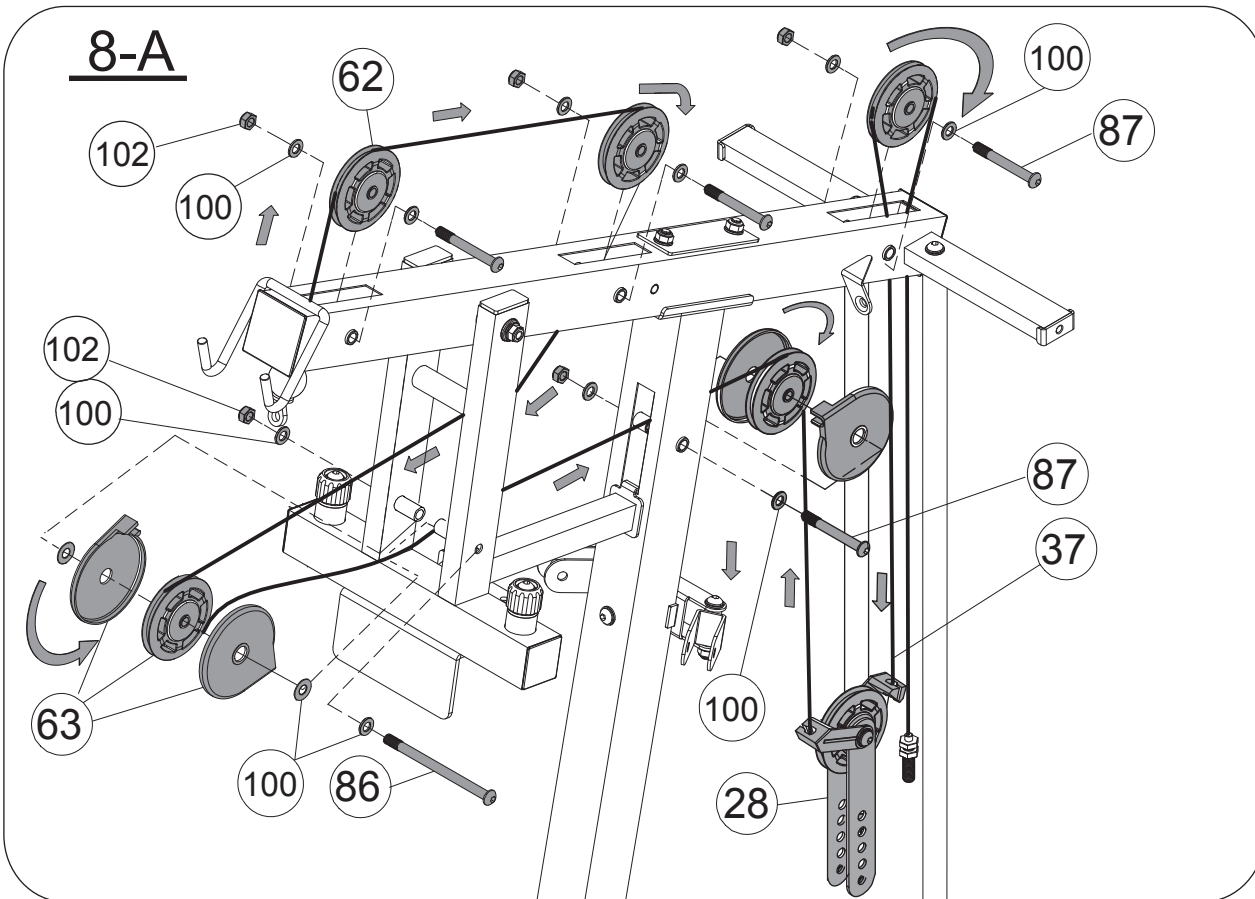

8-A

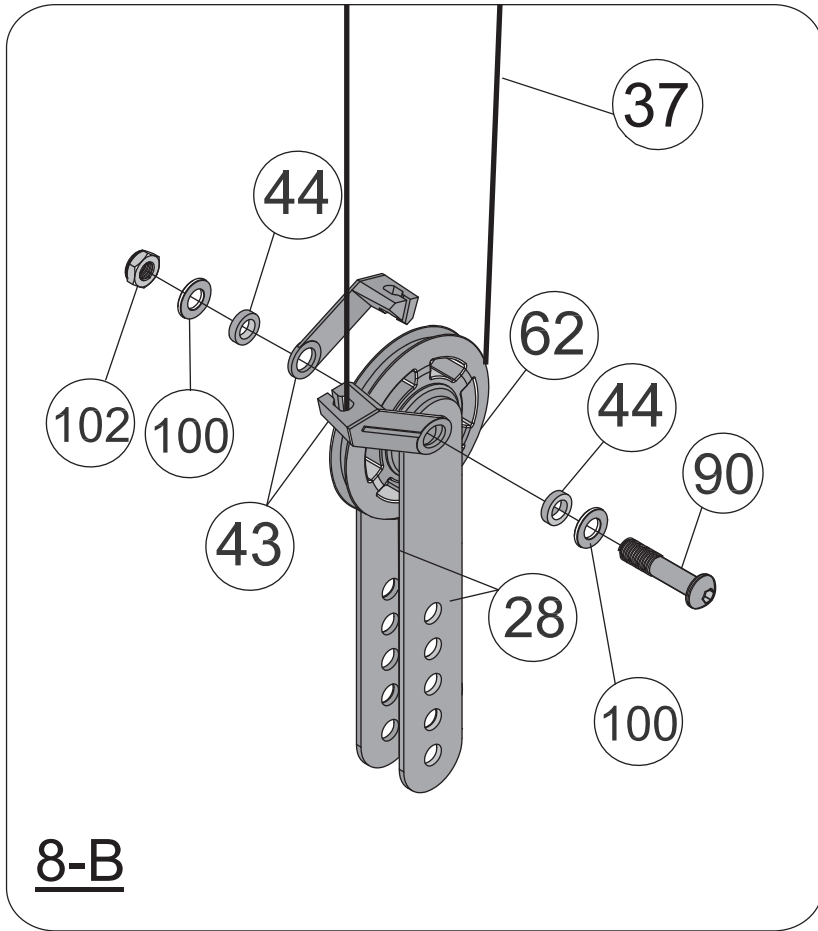

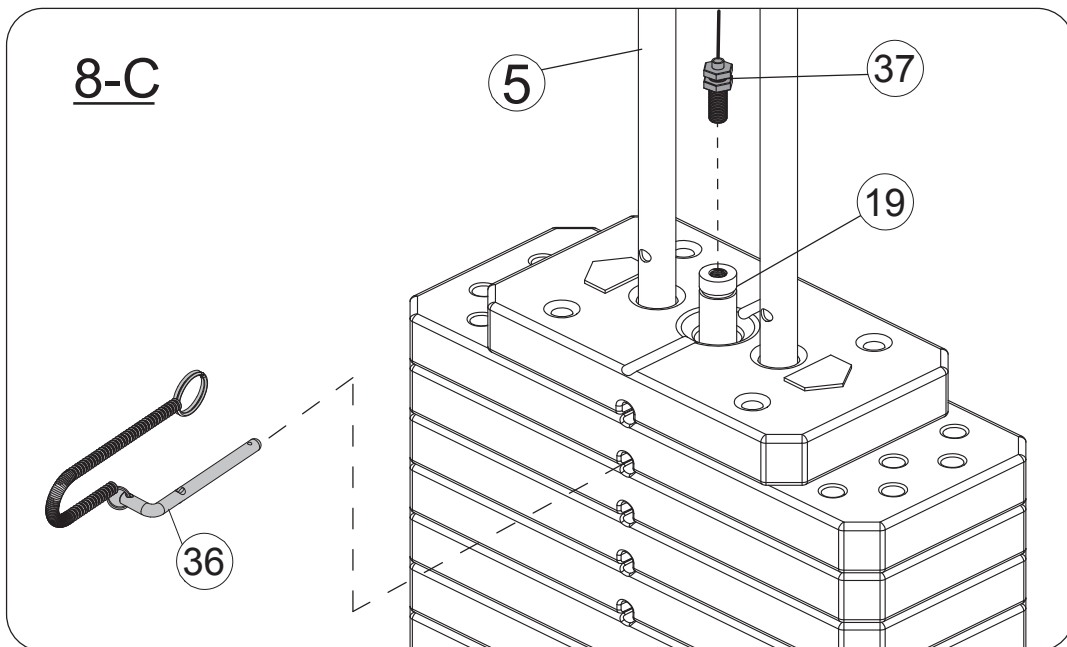

8-B



8-C

8-B
8-C

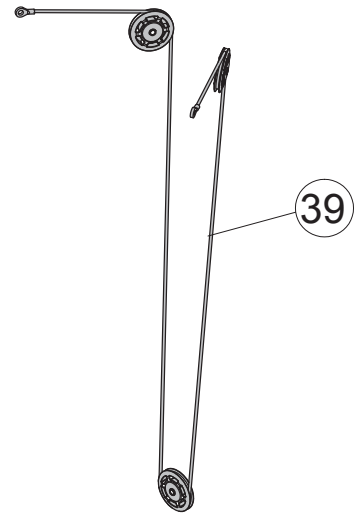
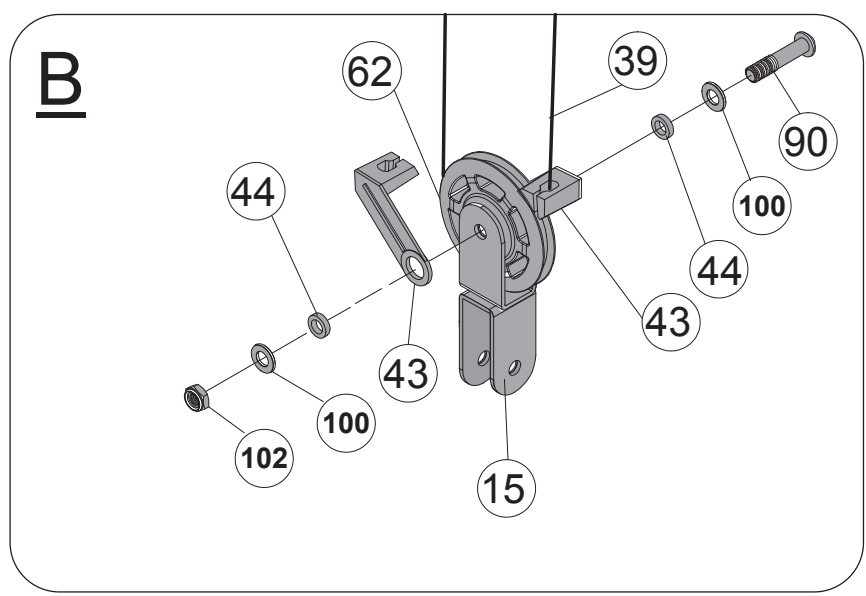
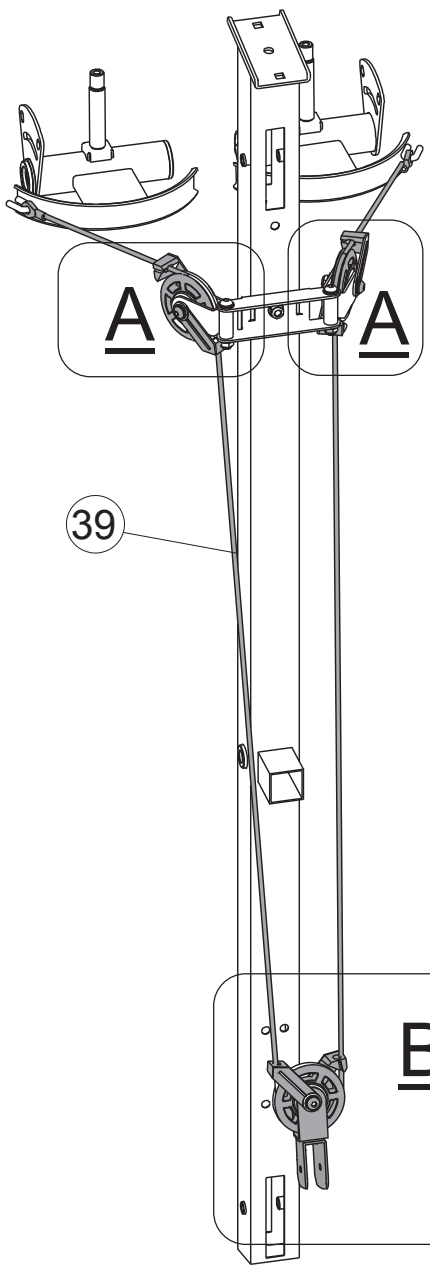
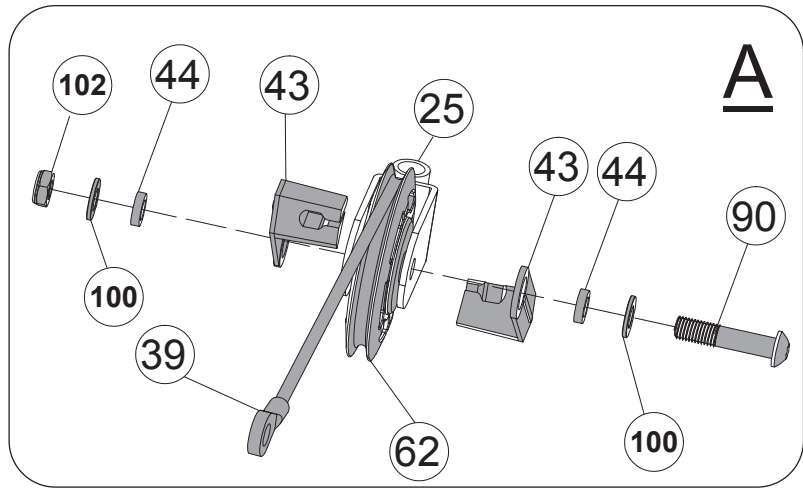
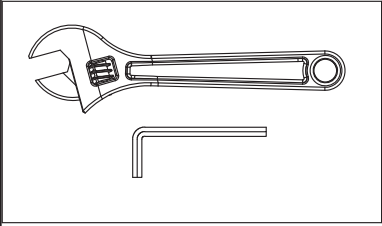
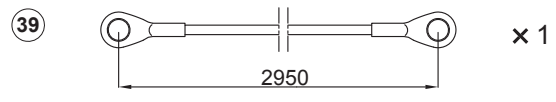

- 90  × 3 M10×50mm
- 100  × 6 Φ20×Φ10.5
- 102  × 3 M10

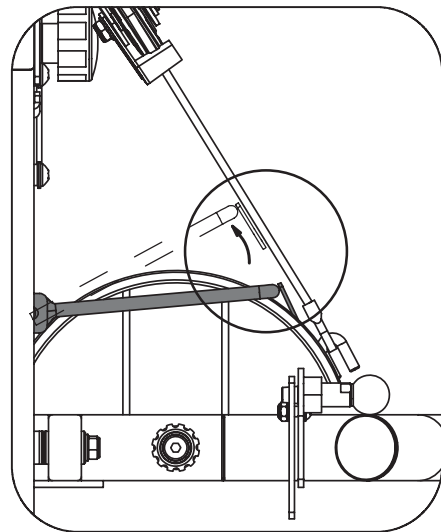
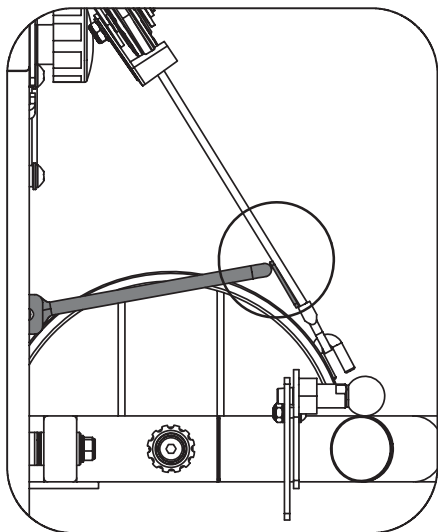
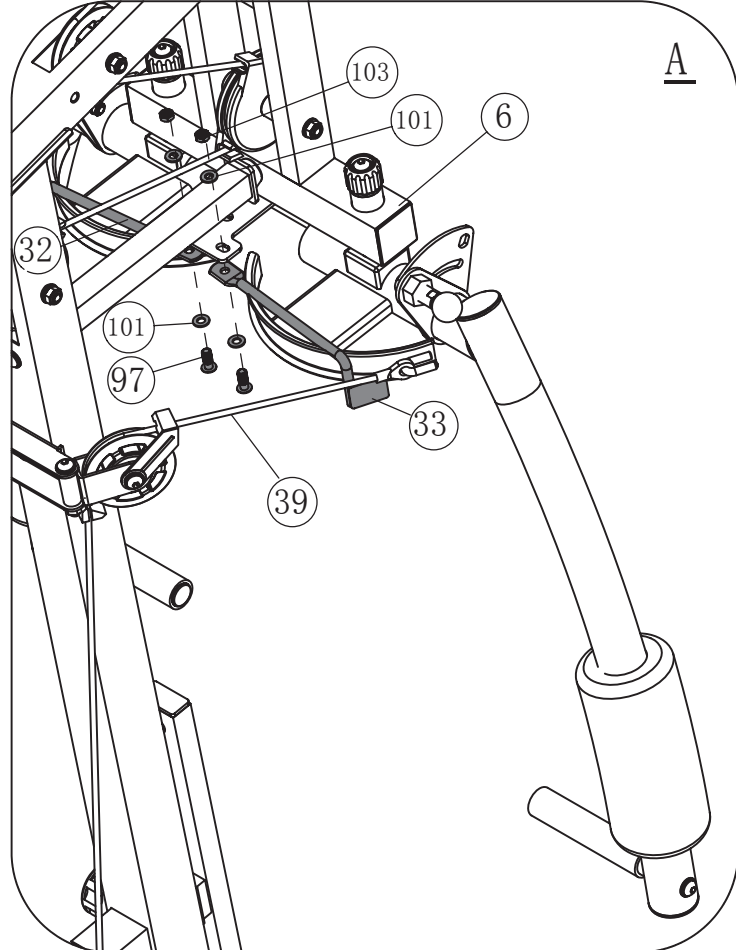
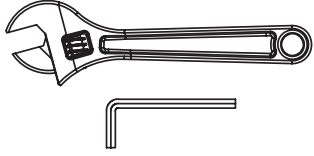

- | | | | |
|----|---|-----|------------|
| ⑨7 |  | × 2 | M8 × 18mm |
| ⑩1 |  | × 4 | Φ16 × Φ8.4 |
| ⑩3 |  | × 2 | M8 |



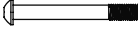

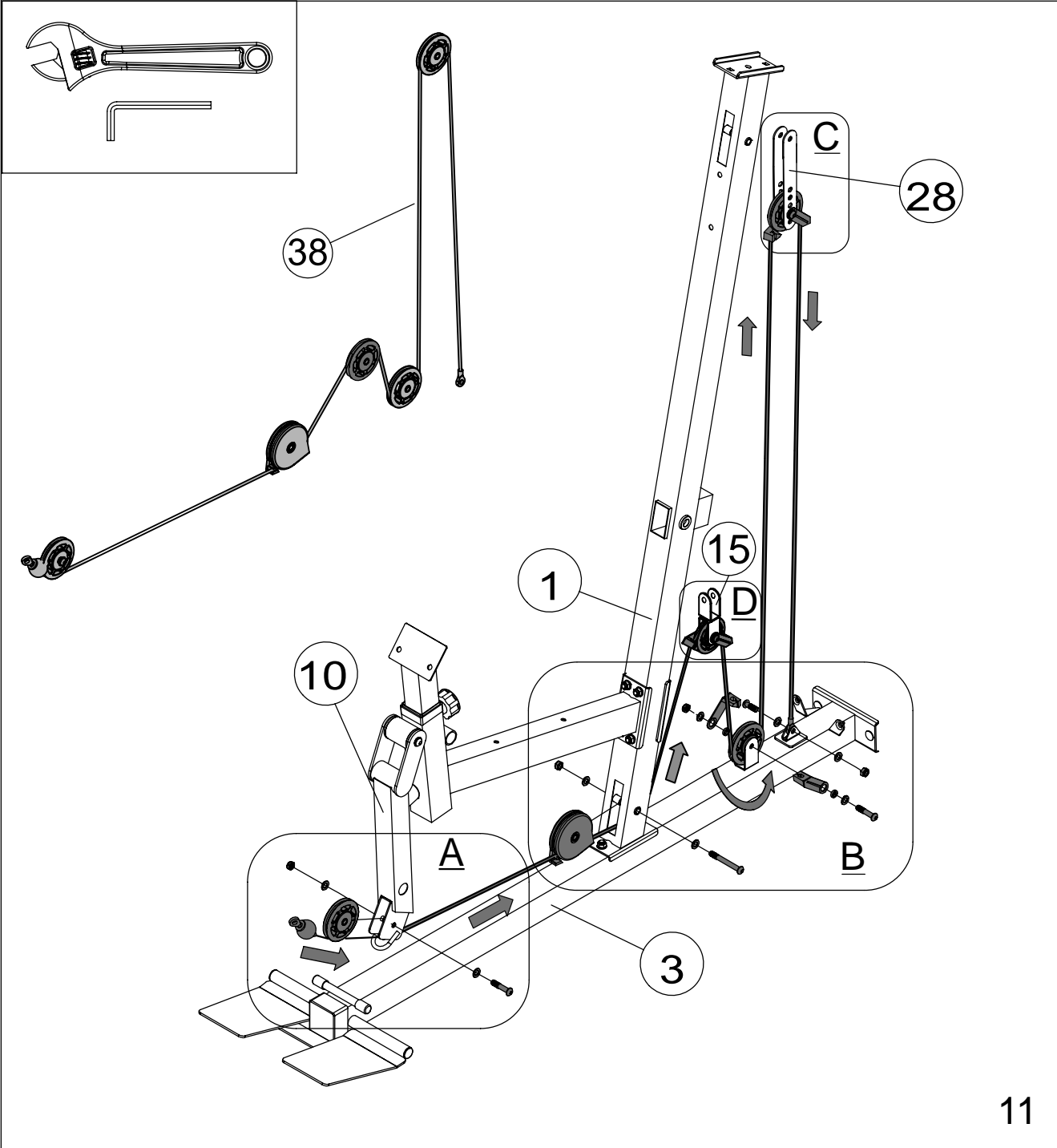
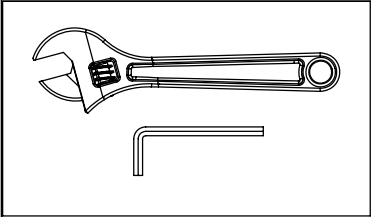
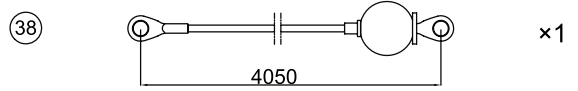

10

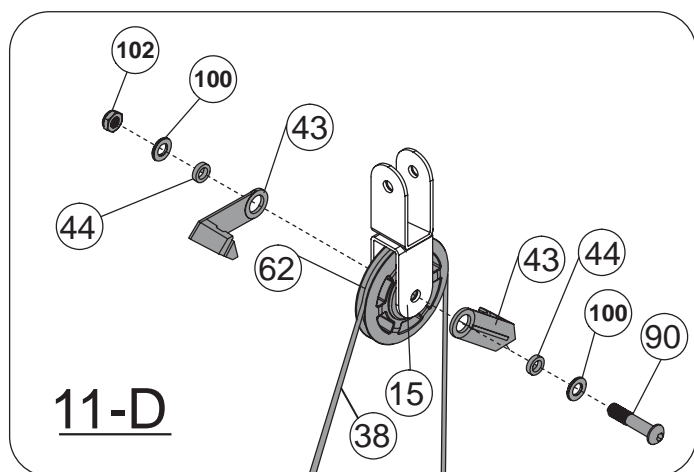
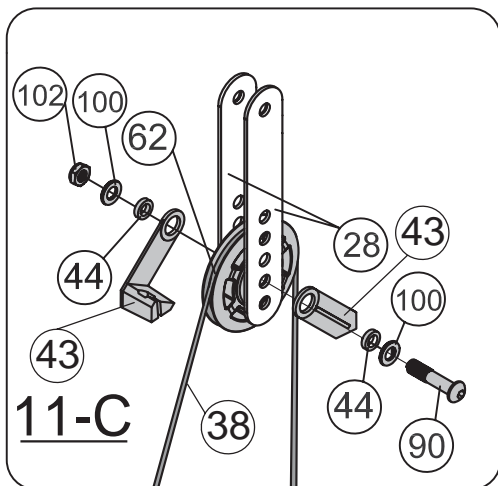
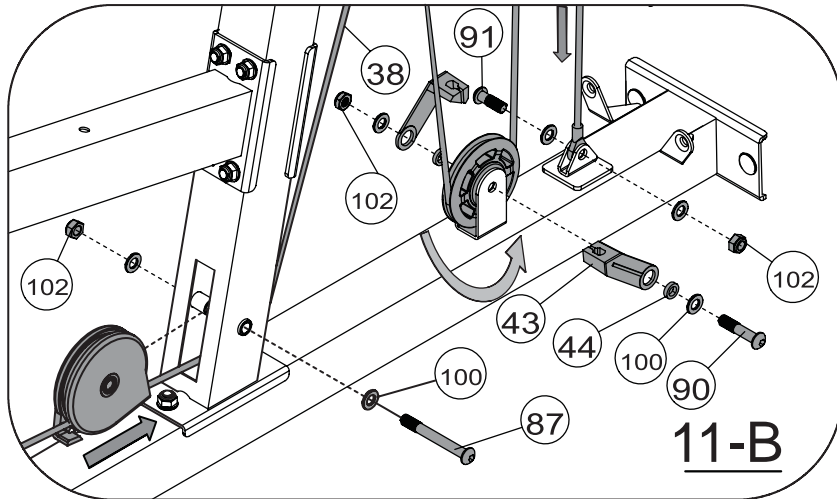
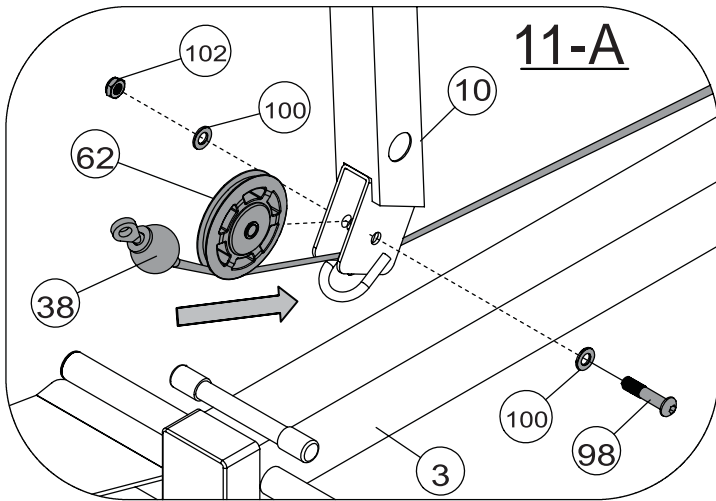
- 87  ×1 M10×85mm
- 90  ×3 M10×50mm
- 98  ×1 M10×45mm
- 91  ×1 M10×30mm
- 100  ×12 Φ20×Φ10.5
- 102  ×6 M10



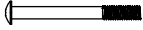

11-A 11-B
11-C 11-D

94		× 2	M8×85mm
95		× 2	M8×40mm
97		× 2	M8×18mm
101		× 6	Φ16×Φ8.4

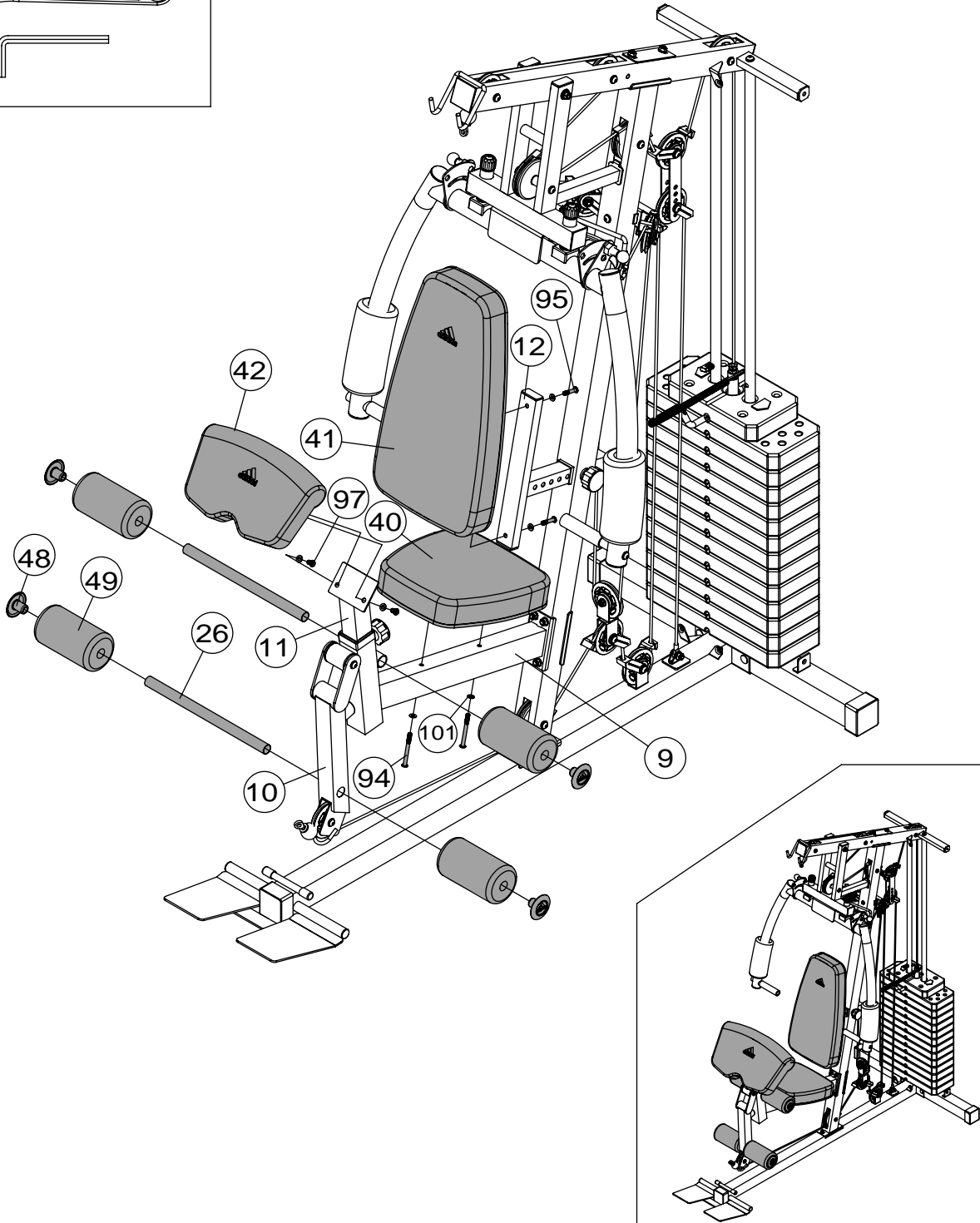
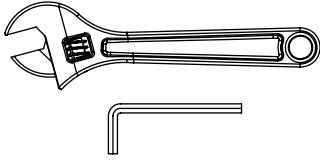

12

93



12 M10×16mm

100



12 Φ20×Φ10.5

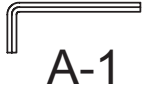

A-1

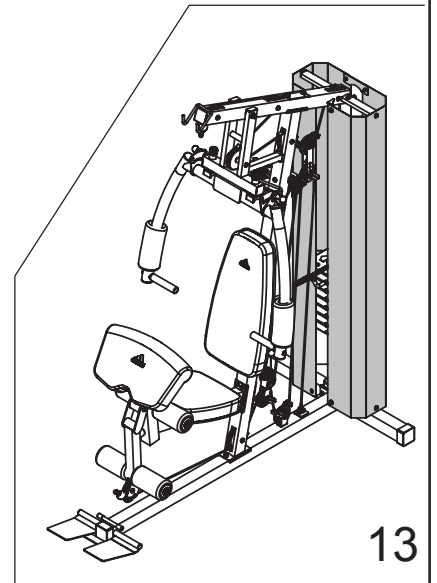
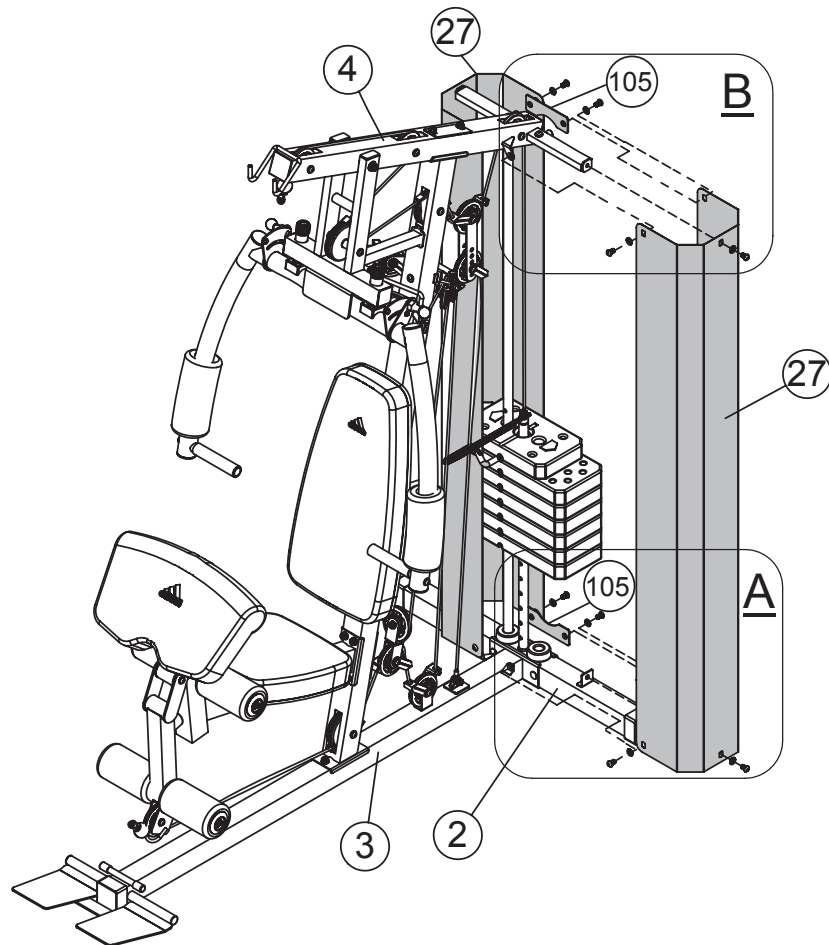
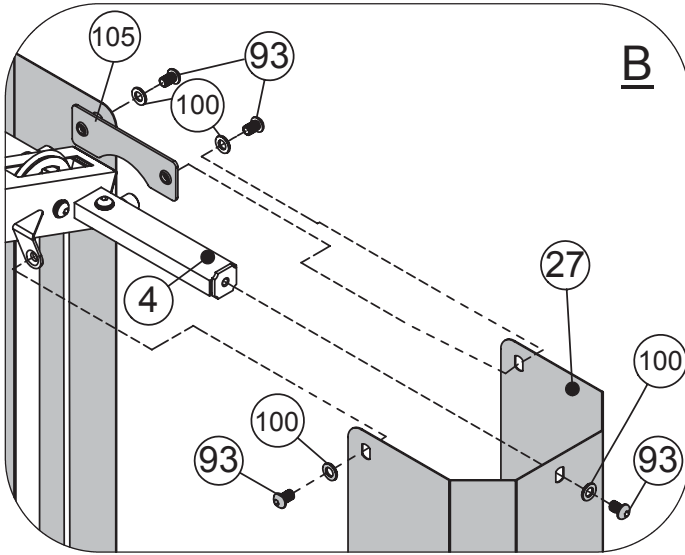
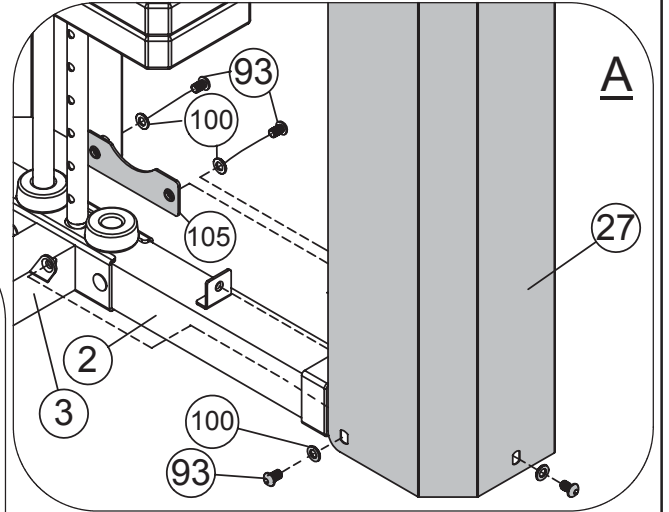

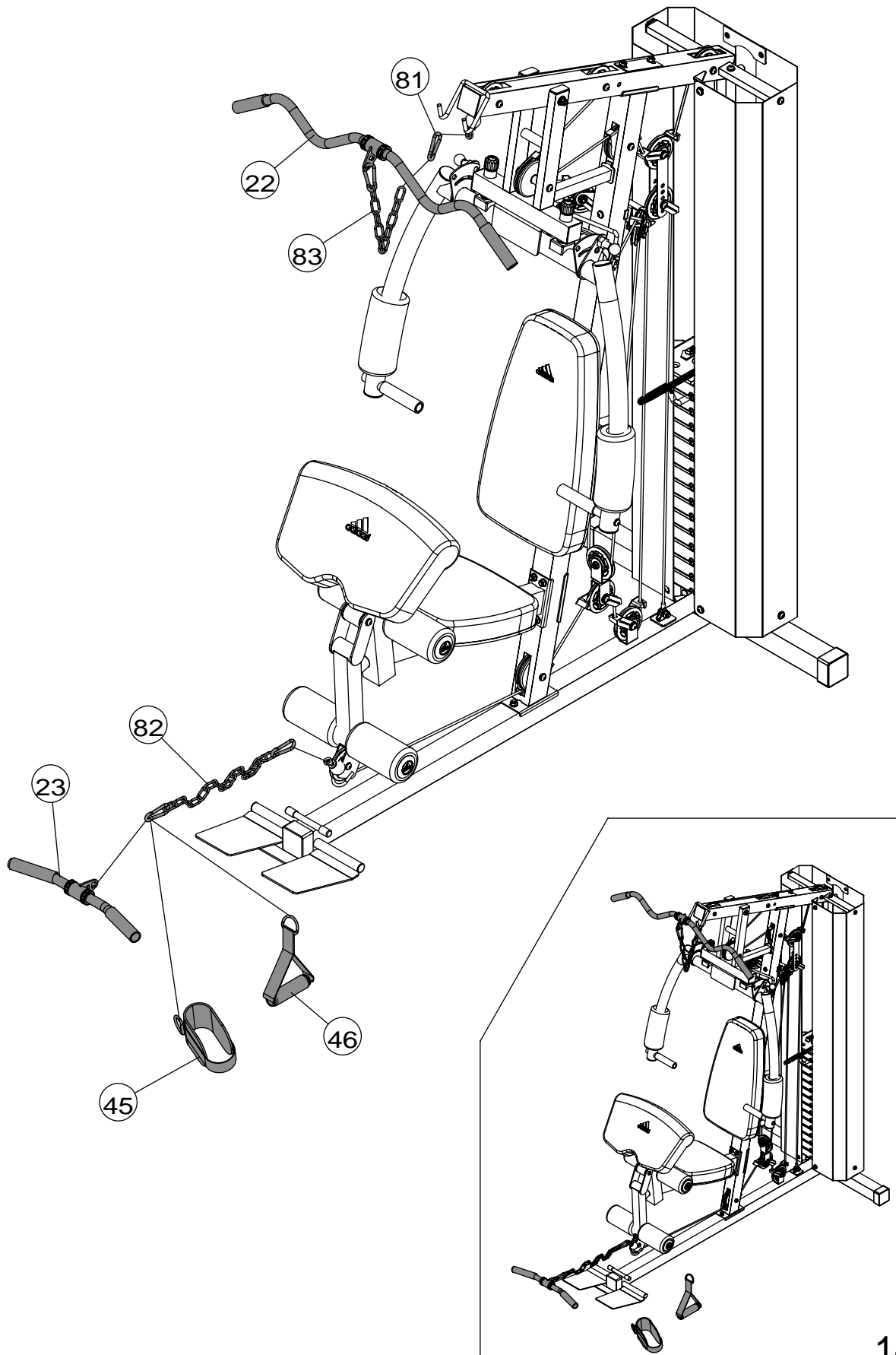

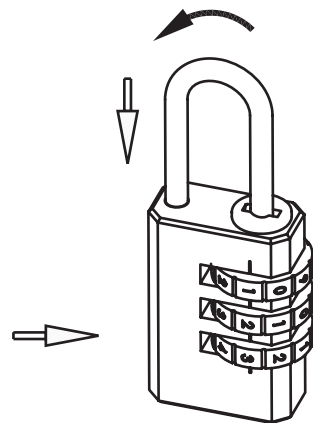
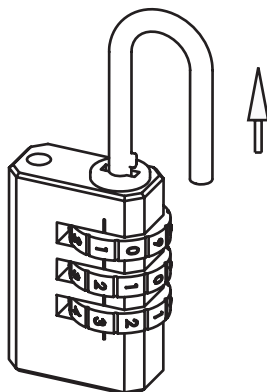
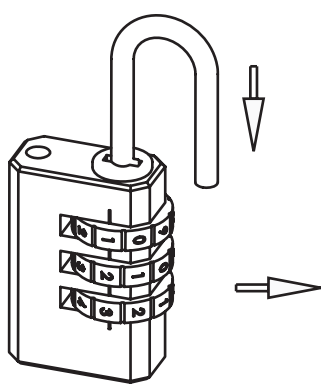
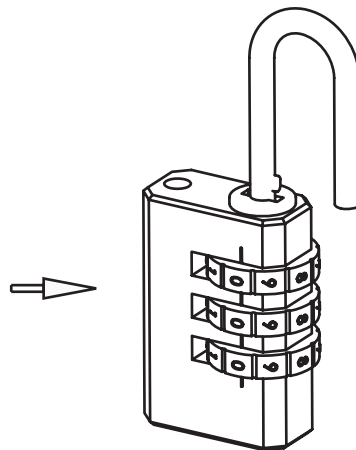
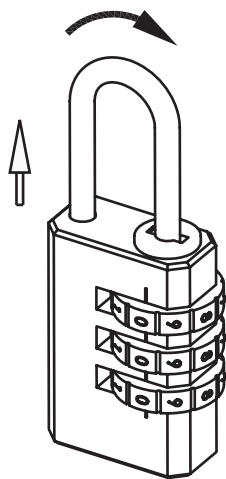
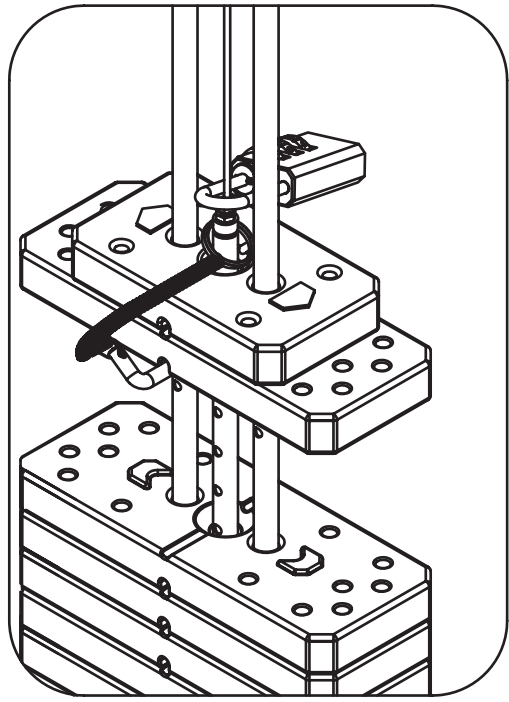
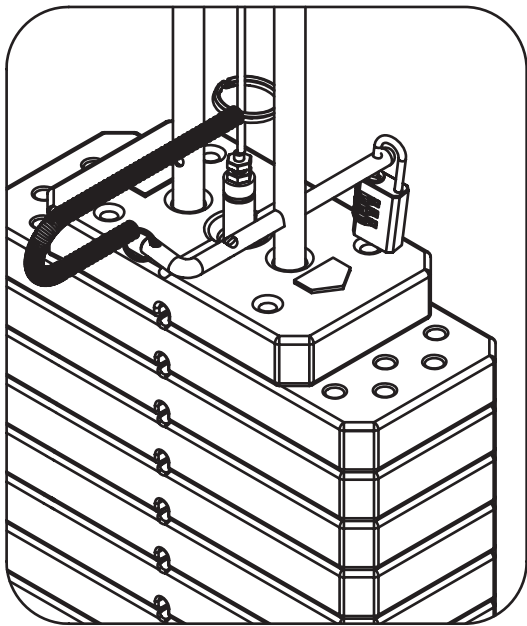

15

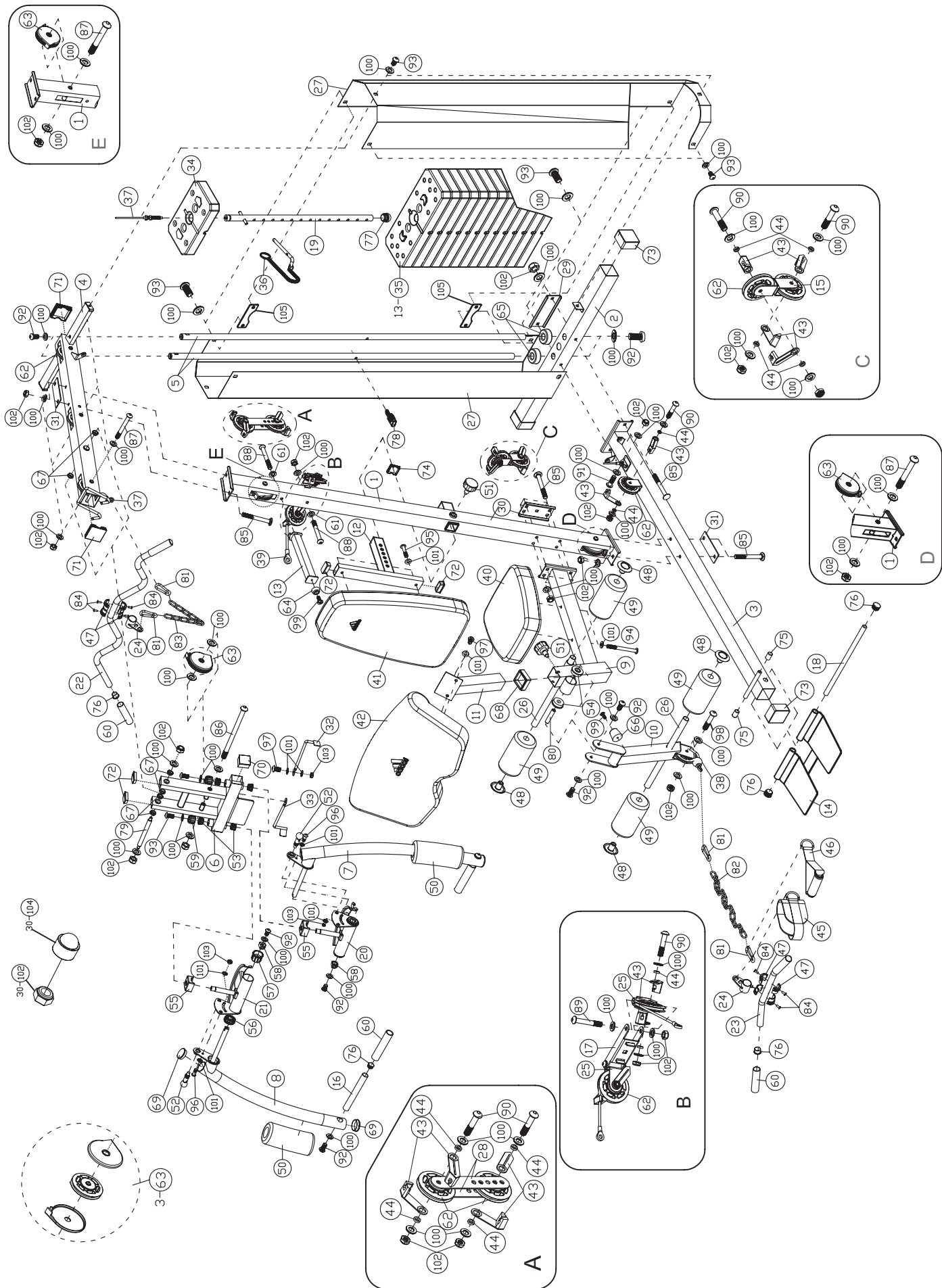

PART NO.	DESCRIPTION UK	DESCRIPTION GERMANY	SIZE	QTY
1	Front Vertical Frame	vor Vertikalrahmen		1
2	Rear Base Frame	hinten Grundrahmen		1
3	Base Frame	Grundrahmen		1
4	Upper Frame	oberen Rahmen		1
5	Guide Rod	Führungsstange		2
6	Front Press Base	vorne drücken Basis		1
7	Left Butterfly	links Schmetterling		1
8	Right Butterfly	Recht Schmetterling		1
9	Seat Support	Sitzträger		1
10	Leg Developer	Bein-Entwickler		1
11	Arm Curl Stand	Arm-Curl stehen		1
12	Backrest Adjustment Frame	Lehnenverstellung Rahmen		1
13	Front Press Stopper	vorne drücken Stopper		1
14	Foot Plate	Fußplatte		1
15	Angled Floating Pulley Bracket	abgewinkelt schwimmende Scheibe Halterung		1
16	Front Press Handle	vorne drücken Griff		2
17	Swivel Pulley Bracket Frame	Schwenk-Riemenscheibe Halterung Rahmen		1
18	Foot Plate Tube	Fußplatte Rohr		1
19	Selector Rod	Schaltstange		1
20	Left Butterfly Adjustment Frame	links Schmetterling Verstelleinheit		1
21	Right Butterfly Adjustment Frame	Recht Schmetterling Verstelleinheit		1
22	Lat Bar	lat bar		1
23	Shiver Bar	Schauer bar		1
24	Rotate Ring	Drehring		2
25	Swivel Pulley Bracket	Schwenk-Riemenscheibe Halterung		2
26	Foam Tube	Schaumrohr	Ø25mmx400mm	2
27	Weight Stack Cover	Gewichtsblock Abdeckung		2
28	Double Floating Pulley Bracket	Double-Float-Riemenscheibe Halterung	218mm x 38mm	2
29	Bracket	Klammer	180mm x 66mm	1
30	Bracket	Klammer	140mm x 65mm	1
31	Bracket	Klammer	140mm x 50mm	2
32	Left Pinch Protector	links Prise Beschützer		1
33	Right Pinch Protector	richtigen Prise Beschützer		1
34	Selector Stem	Wahlschalter Stammzellen		1
35	Weight Plate	Hantelscheibe		13
36	Weight Selector Pin	Gewicht Wahlschalter pin		1

37	Upper Cable	obere Kabel	3140mm	1
38	Lower Cable	unteren Kabel	4050mm	1
39	Butterfly Cable	Schmetterling-Kabel	2950mm	1
40	Seat Pad	Sitzpolster		1
41	Backrest Board	Rückenlehne Bord		1
42	Arm Curl Pad	Arm-Curl-Pad		1
43	Cable Retainer	Kabelhalter		14
44	Cable Retainer Bushing	Kabel Haltebuchse	Ø16mmxØ11mm	14
45	Ankle Strap	Riemchen		1
46	Single Handle	einziges Handgriff		1
47	Plastic Ring	Kunststoffring		8
48	Foam Roll End Cap	Schaumstoffrolle Endkappe		4
49	Foam Roll	Schaumstoffrolle		4
50	Butterfly Large Foam Roll	Schmetterling große Schaumstoffrolle		2
51	Lock Knob	Feststellknopf	M18	2
52	Quick Release Lock Pin	Schnellverschluss pin		2
53	Bushing	Buchse	Ø32mm x 19mm	4
54	Bushing	Buchse	Ø50mm Ø16mm	2
55	Butterfly Axle Bushing	Schmetterling Achse Buchse	41mm x Ø21mm	2
56	Spacer	spacer	Ø50mm x 20mm	2
57	Spacer	spacer	Ø50mm x 35mm	2
58	Spacer	spacer	Ø32mm x 12mm	2
59	Lock Ring	Sicherungsring		2
60	Grip	Griff	150mm	6
61	Washer	Waschmaschine	Ø30 x Ø10.5mm	2
62	Pulley	Flaschenzug		11
63	Pulley With Cover	Riemenscheibe mit Deckel		3
64	Rubber Bumper	Gummipuffer	Ø38mm x 15mm	1
65	Rubber Bumper	Gummipuffer	Ø62mm x 25mm	2
66	Rubber Bumper	Gummipuffer	Ø45mm x 40mm	1
67	Bushing	Buchse	Ø25mm x 10mm	6
68	Sleeve	Ärmel	60mm x 50mm	1
69	Round End Cap	runde Endkappe	Ø50mm	4
70	Square End Cap	Platz Endkappe	50mm x 50mm	2
71	Upper Frame End Cap	oberen Rahmen Endkappe	65mm x 65mm	2
72	End Cap	Endkappe	25mm x 50mm	4
73	Base Frame End Cap	Grundrahmen Endkappe	65mm x 65mm	3
74	End Cap	Endkappe	38mm x38mm	1

75	Rubber Bumper	Gummipuffer	Ø20mm x 29mm	2
76	End Cap	Endkappe	Ø25mm	8
77	Cone-shaped End Cap	kegelförmigen Endkappe	Ø25mm	1
78	Combination Lock	Schloss		1
79	Axle	Achse	M10 x 169mm	1
80	Leg Developer Axle	Bein-Entwickler Achse	M10 x 71mm	1
81	Hook	Haken		4
82	Chain	Kette	15-link	1
83	Chain	Kette	10-link	1
84	Rivet	Niet	Ø4mm x 10mm	8
85	Carriage Bolt	Schlossschraube	M10 x 85mm	10
86	Allen Bolt	Inbusschraube	M10 x 150mm	1
87	Allen Bolt	Inbusschraube	M10 x 85mm	5
88	Allen Bolt	Inbusschraube	M10 x 80mm	2
89	Allen Bolt	Inbusschraube	M10 x 65mm	2
90	Allen Bolt	Inbusschraube	M10 x 50mm	7
91	Allen Bolt	Inbusschraube	M10 x 30mm	1
92	Allen Bolt	Inbusschraube	M10 x 20mm	10
93	Allen Bolt	Inbusschraube	M10 x 16mm	14
94	Allen Bolt	Inbusschraube	M8 x 85mm	2
95	Allen Bolt	Inbusschraube	M8 x 40mm	2
96	Allen Bolt	Inbusschraube	M8 x 22mm	2
97	Allen Bolt	Inbusschraube	M8 x 18mm	4
98	Allen Bolt	Inbusschraube	M10 x 45mm	1
99	Philips Screw	Kreuzschlitzschraube	M6 x 16mm	2
100	Washer	Waschmaschine	Ø10mm	73
101	Washer	Waschmaschine	Ø8mm	14
102	Aircraft Nut	Flugzeuge Mutter	M10	30
103	Aircraft Nut	Flugzeuge Mutter	M8	4
104	Bolt Cover Cap	Bolzen Abdeckkappe	M10	30
105	Bracket	Klammer	155mm x 50mm	2
	Allen Wrench	Imbuss	#5	1
	Allen Wrench	Imbuss	#6	2

ADBE-10250 WEIGHT RESISTANCE CHART

Weight Plate	Front Press	Back Press	Butterfly	Lat Pull	Low Pulley
1	13.6	14.7	5.7	13.6	15.9
2	22.7	24.5	9.1	20.5	22.7
3	31.8	34.3	12.5	27.3	29.5
4	40.9	44.1	15.9	34.1	36.3
5	50	53.9	19.3	40.9	43.1
6	59.1	63.8	22.7	47.7	49.9
7	68.2	73.5	26.1	54.5	56.7
8	77.3	83.3	29.5	61.3	63.5
9	86.4	93.1	32.9	68.1	70.3
10	95.5	102.9	36.3	74.9	77.1
11	104.5	112.7	39.7	81.7	83.9
12	113.6	122.5	43.1	88.5	90.7
13	122.7	132.3	46.5	95.3	97.5



= 7.3 kg