







DE	Gebrauchsanleitung / Montageanleitung	2		Talis Classic 14165000		PuraVida 15665XXX		Metris 31456000
FR	Mode d'emploi / Instructions de montage	3						
EN	Instructions for use / assembly instructions	4						
IT	Istruzioni per l'uso / Istruzioni per Installazione	5						
ES	Modo de empleo / Instrucciones de montaje	6						
NL	Gebruiksaanwijzing / Handleiding	7						
DK	Brugsanvisning / Monteringsvejledning	8		Metris S 31665000		Metropol Classic 31365XXX		Focus 31965000
PT	Instruções para uso / Manual de Instalação	9						
PL	Instrukcja obsługi / Instrukcja montażu	10						
CS	Návod k použití / Montážní návod	11						
SK	Návod na použitie / Montážny návod	12		Metris Classic 31676XXX		Metris 31685000		Talis S / Talis 32675XXX
ZH	用户手册 / 组装说明	13						
RU	Руководство пользователя / Инструкция по монтажу	14						
FI	Käyttöohje / Asennusohje	15						
SV	Bruksanvisning / Monteringsanvisning	16		Logis 71605000		Talis S 72605000		Talis E 71765XXX
LT	Vartotojo instrukcija / Montavimo instrukcijos	17						
HR	Upute za uporabu / Uputstva za instalaciju	18						
TR	Kullanım kılavuzu / Montaj kılavuzu	19						
RO	Manual de utilizare / Instrucțiuni de montare	20						
EL	Οδηγίες χρήσης / Οδηγία συναρμολόγησης	21		Metropol 32565XXX		Logis E 71603000		Logis Loop 71267000
SL	Navodilo za uporabo / Navodila za montažo	22						
ET	Kasutusjuhend / Paigaldusjuhend	23						
LV	Lietošanas pamācība / Montāžas instrukcija	24						
SR	Uputstvo za upotrebu / Uputstvo za montažu	25						
NO	Bruksanvisning / Montasjeveiledning	26						
BG	Инструкция за употреба / Ръководство за монтаж	27		Metropol 74565000		Novus 71065000		Novus Loop 71365000
SQ	Udhëzuesi i përdorimit / Udhëzime rreth montimit	28						
AR	دليل الاستخدام / تعليمات التجميع	29						
HU	Használati útmutató / Szerelési útmutató	30						



Sicherheitshinweise

- ⚠ Bei der Montage müssen zur Vermeidung von Quetsch- und Schnittverletzungen Handschuhe getragen werden.
- ⚠ Das Produkt darf nur zu Bade-, Hygiene- und Körperreinigungszwecken eingesetzt werden.
- ⚠ Große Druckunterschiede zwischen den Kalt- und Warmwasseranschlüssen müssen ausgeglichen werden.

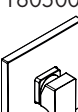
Montagehinweise

- Vor der Montage muss das Produkt auf Transportschäden untersucht werden. Nach dem Einbau werden keine Transport- oder Oberflächenschäden anerkannt.
- Die Leitungen und die Armatur müssen nach den gültigen Normen montiert, gespült und geprüft werden.
- Die in den Ländern jeweils gültigen Installationsrichtlinien sind einzuhalten.

Technische Daten

Betriebsdruck:	max. 1 MPa
Empfohlener Betriebsdruck:	0,1 - 0,5 MPa
Prüfdruck:	1,6 MPa (1 MPa = 10 bar = 147 PSI)
Heißwassertemperatur:	max. 70 °C
Empfohlene Heißwassertemperatur:	65 °C
Thermische Desinfektion:	max. 70 °C / 4 min

Das Produkt ist ausschließlich für Trinkwasser konzipiert!

Symbolerklärung



Kein essigsäurehaltiges Silikon verwenden!

Justierung (siehe Seite 34)

Einstellen der Warmwasserbegrenzung. In Verbindung mit Durchlauferhitzern ist eine Warmwassersperre nicht zu empfehlen.



Maße (siehe Seite 36)



Durchflussdiagramm (siehe Seite 37)

freier Durchfluss



Serviceteile (siehe Seite 38)

- XXX = Farbcodierung
- 000 = Chrom
- 090 = Chrom/Gold-Optik
- 140 = Brushed Bronze
- 340 = Brushed Black Chrome
- 400 = Weiß/Chrom
- 670 = Mattschwarz
- 700 = Mattweiß
- 990 = Polished Gold-Optic



Sonderzubehör (siehe Seite 41)

nicht im Lieferumfang enthalten

- Verlängerung 25 mm #13595000
- Verlängerung 22 mm (bei geringer Einbautiefe)



Reinigung (siehe Seite 42)



Bedienung (siehe Seite 35)



Prüfzeichen (siehe Seite 48)

Störung

Ursache

Abhilfe

Armatur schwergängig	- Kartusche defekt, verkalkt	- Kartusche austauschen
Armatur tropft	- Kartusche defekt	- Kartusche austauschen
Zu niedrige Warmwassertemperatur, kein Kaltwasser. Durchlauferhitzer springt an, wenn Kaltwasser angewählt wird.	- Warmwasserbegrenzung falsch eingestellt - Kreuzfluss	- Warmwasserbegrenzung einstellen - Kartusche austauschen



Consignes de sécurité

- △ Lors du montage, porter des gants de protection pour éviter toute blessure par écrasement ou coupure.
- △ Le produit ne doit servir qu'à se laver et à assurer l'hygiène corporelle.
- △ Il est conseillé d'équilibrer les pressions de l'eau chaude et froide.

Instructions pour le montage

- Avant son montage, s'assurer que le produit n'a subi aucun dommage pendant le transport. Après le montage, tout dommage de transport ou de surface ne pourra pas être reconnu.
- Les conduites et la robinetterie doivent être montés, rincés et contrôlés selon les normes en vigueur.
- Les directives d'installation en vigueur dans le pays concerné doivent être respectées.

Informations techniques

Pression de service autorisée: max. 1 MPa
 Pression de service conseillée: 0,1 - 0,5 MPa
 Pression maximum de contrôle: 1,6 MPa
 (1 MPa = 10 bar = 147 PSI)

Température d'eau chaude: max. 70 °C
 Température recommandée: 65 °C
 Désinfection thermique: max. 70 °C / 4 min

Le produit est exclusivement conçu pour de l'eau potable!

Description du symbole



Ne pas utiliser de silicone contenant de l'acide acétique!



Étalonnage (voir pages 34)

Réglage de la limitation d'eau chaude. En liaison avec les chauffe-eau, un blocage de l'eau chaude n'est pas recommandable.



Dimensions (voir pages 36)

Diagramme du débit (voir pages 37)

débit libre



Pièces détachées (voir pages 38)

XXX = Couleurs
 000 = Chromé
 090 = Chromé/Or L'optique
 140 = Brushed Bronze
 340 = Brushed Black Chrome
 400 = Blanc/Chromé
 670 = Matt Black
 700 = Matt White
 990 = Polished Gold-Optic



Accessoires en option (voir pages 41)

ne fait pas partie de la fourniture

- jeu de rallonge 25 mm #13595000
- Rallonge de 22 mm (pour profondeur de montage trop faible)



Nettoyage (voir pages 42)



Instructions de service (voir pages 35)



Classification acoustique et débit (voir pages 48)

Dysfonctionnement

Origine

Solution

Dureté de fonctionnement	- Cartouche défectueuse, entartrée	- Changer la cartouche
Le mitigeur goutte	- Cartouche défectueuse	- Changer la cartouche
Température d'eau chaude trop basse, pas d'eau froide. Le chauffe-eau instantané met en route quand on puise de l'eau froide.	- Limiteur de température mal positionné - Flux inversé	- Positionner le limiteur de température - Changer la cartouche



Safety Notes

- △ Gloves should be worn during installation to prevent crushing and cutting injuries.
- △ The product may only be used for bathing, hygienic and body cleaning purposes.
- △ The hot and cold supplies must be of equal pressures.

Installation Instructions

- Prior to installation, inspect the product for transport damages. After it has been installed, no transport or surface damage will be honoured.
- The pipes and the fixture must be installed, flushed and tested as per the applicable standards.
- The plumbing codes applicable in the respective countries must be observed.

Technical Data

Operating pressure: max. 1 MPa
 Recommended operating pressure: 0,1 - 0,5 MPa
 Test pressure: 1,6 MPa
 (1 MPa = 10 bar = 147 PSI)
 Hot water temperature: max. 70 °C
 Recommended hot water temp.: 65 °C
 Thermal disinfection: max. 70 °C / 4 min
 The product is exclusively designed for drinking water!

Symbol description



Do not use silicone containing acetic acid!

Adjustment (see page 34)

To adjust the hot water limiter. Using a hot water limiter in combination with a continuous flow water heater is not recommended.



Dimensions (see page 36)



Flow diagram (see page 37)

free flow



Spare parts (see page 38)

XXX = Colors
 000 = Chrome Plated
 090 = Chrome Plated/Gold Plated
 140 = Brushed Bronze
 340 = Brushed Black Chrome
 400 = White/Chrome Plated
 670 = Matt Black
 700 = Matt White
 990 = Polished Gold-Optic



Special accessories (see page 41)

order as an extra

- extension 25 mm #13595000
- Extension Set 22 mm (when wall is not deep enough)



Cleaning (see page 42)



Operation (see page 35)



Test certificate (see page 48)

Fault	Cause	Remedy
Mixer stiff	- Cartridge defective, calcified	- Exchange cartridge
Mixer dripping	- Cartridge defective	- Exchange cartridge
Hot water temperature too low, no cold water. Instantaneous water heater starts up when cold water is selected.	- Hot water limiter incorrectly set	- Set hot water limiter
	- Crossflow	- Exchange cartridge



Indicazioni sulla sicurezza

- ⚠ Durante il montaggio, per evitare ferite da schiacciamento e da taglio bisogna indossare guanti protettivi.
- ⚠ Il prodotto deve essere utilizzato esclusivamente per fare il bagno e per l'igiene del corpo.
- ⚠ Attenzione! Compensare le differenze di pressione tra i collegamenti dell'acqua fredda e dell'acqua calda.

Istruzioni per il montaggio

- Prima del montaggio è necessario controllare che non ci siano stati danni durante il trasporto. Una volta eseguito il montaggio, non verranno riconosciuti eventuali danni di trasporto o delle superfici.
- Montare, lavare e controllare tubature e rubinetteria rispettando le norme correnti.
- Vanno rispettate le direttive di installazione nazionali vigenti nel rispettivo paese.

Dati tecnici

Pressione d'uso: max. 1 MPa
 Pressione d'uso consigliata: 0,1 - 0,5 MPa
 Pressione di prova: 1,6 MPa
 (1 MPa = 10 bar = 147 PSI)

Temperatura dell'acqua calda: max. 70 °C
 Temp. dell'acqua calda consigliata: 65 °C
 Disinfezione termica: max. 70 °C / 4 min

Il prodotto è concepito esclusivamente per acqua potabile!

Descrizione simbolo

 Non utilizzare silicone contenente acido acetico!

 **Taratura** (vedi pagg. 34)

Regolazione del limitatore di erogazione d'acqua calda. Un limitatore di erogazione di acqua calda in combinazione con le caldaie istantanee non è consigliabile.

 **Ingombri** (vedi pagg. 36)

 **Diagramma flusso** (vedi pagg. 37)
portata libero

 **Parti di ricambio** (vedi pagg. 38)

XXX = Trattamento
 000 = Cromato
 090 = Cromo/Dorato Ottica
 140 = Brushed Bronze
 340 = Brushed Black Chrome
 400 = Bianco/Cromato
 670 = Matt Black
 700 = Matt White
 990 = Polished Gold-Optic

 **Accessori speciali** (vedi pagg. 41)

- non contenuto nel volume di fornitura
- Prolunga 25 mm #13595000
 - Prolunga 22 mm x set esterno (in caso di incasso troppo esterno al muro)

 **Pulitura** (vedi pagg. 42)

 **Procedura** (vedi pagg. 35)

 **Segno di verifica** (vedi pagg. 48)

Problema	Possibile causa	Rimedio
Miscelatore duro	- Cartuccia difettosa	- Sostituire la cartuccia
Miscelatore gocciola	- Cartuccia difettosa	- Sostituire la cartuccia
Temperatura dell'acqua calda troppo bassa, niente acqua fredda, caldaia istantanea si accende quando si seleziona acqua fredda	- Limitazione dell'acqua calda regolata male - Flusso incrociato	- Regolare la limitazione dell'acqua calda - Sostituire la cartuccia



Indicaciones de seguridad

- ⚠ Durante el montaje deben utilizarse guantes para evitar heridas por aplastamiento o corte.
- ⚠ El producto solo debe ser utilizado para fines de baño, higiene y limpieza corporal.
- ⚠ Grandes diferencias de presión en servicio entre agua fría y agua caliente deben equilibrarse.

Indicaciones para el montaje

- Antes del montaje se debe examinar el producto contra daños de transporte. Después de la instalación no se reconoce ningún daño de transporte o de superficie.
- Los conductos y la grifería deben montarse, lavarse y comprobarse según las normas vigentes.
- Es obligatorio el cumplimiento de las directrices de instalación vigentes en el país respectivo.

Datos técnicos

Presión en servicio:	max. 1 MPa
Presión recomendada en servicio:	0,1 - 0,5 MPa
Presión de prueba:	1,6 MPa (1 MPa = 10 bar = 147 PSI)
Temperatura del agua caliente:	max. 70 °C
Temp. recomendada del agua caliente:	65 °C
Desinfección térmica:	max. 70 °C / 4 min

El producto ha sido concebido exclusivamente para agua potable.

Descripción de símbolos



No utilizar silicona que contiene ácido acético!



Ajuste (ver página 34)

Ajuste del límite de agua caliente. En combinación con calentadores continuos no es recomendable utilizar un bloqueo de agua caliente.



Dimensiones (ver página 36)



Diagrama de circulación
(ver página 37)

caudal libre



Repuestos (ver página 38)

XXX = Acabados
 000 = Cromado
 090 = Cromo/Oro Óptica
 140 = Brushed Bronze
 340 = Brushed Black Chrome
 400 = Blanco/Cromado
 670 = Matt Black
 700 = Matt White
 990 = Polished Gold-Optic



Opcional (ver página 41)

no incluido en el suministro

- Prolongación 25 mm #13595000
- Alargo 22 mm (en caso de pared delgada)



Limpiar (ver página 42)



Manejo (ver página 35)



Marca de verificación
(ver página 48)

Problema

Causa

Solución

Manecilla va dura	- cartucho dañado	- cambiar el cartucho
Grifo pierde agua	- cartucho dañado	- cambiar el cartucho
Temperatura del agua caliente demasiado baja, agua fría	- tope de agua caliente mal	- ajustar tope
calentador se dispara al abrir agua fría	- Flujo cruzado	- cambiar el cartucho





Veiligheidsinstructies

- △ Bij de montage moeten ter voorkoming van knel- en snijwonden handschoenen worden gedragen.
- △ Het product mag alleen voor het wassen, hygiënische doeleinden en voor de lichaamreiniging worden gebruikt.
- △ Grote drukverschillen tussen de koud- en warmwater-toevoer dienen vermeden te worden.

Montage-instructies

- Vóór de montage moet het product gecontroleerd worden op transportschade. Na de inbouw wordt geen transport- of oppervlakteschade meer aanvaard.
- De leidingen en armaturen moeten gemonteerd, gespoeld en gecontroleerd worden volgens de geldige normen.
- De in de overeenkomstige landen geldende installatierichtlijnen moeten nageleefd worden.

Technische gegevens

Werkdruk: max.	max. 1 MPa
Aanbevolen werkdruk:	0,1 - 0,5 MPa
Getest bij:	1,6 MPa (1 MPa = 10 bar = 147 PSI)
Temperatuur warm water:	max. 70 °C
Aanbevolen warm water temp.:	65 °C
Thermische desinfectie:	max. 70 °C / 4 min

Het product is uitsluitend ontworpen voor drinkwater!

Symboolbeschrijving

 Gebruik geen zuurhoudende silicone!

 **Instellen** (zie blz. 34)

Instellen van de warmwaterbegrenzing. In combinatie met een doorstromer is een warmwaterblokkering niet aanbevelenswaardig.

 **Maten** (zie blz. 36)

 **Doorstroomdiagram** (zie blz. 37)
vrije doorstroom

 **Service onderdelen** (zie blz. 38)

XXX = Kleuren
000 = Verchroomd
090 = Chroom/Verguld-Look
140 = Brushed Bronze
340 = Brushed Black Chrome
400 = Wit/Verchroomd
670 = Matt Black
700 = Matt White
990 = Polished Gold-Optic

 **Toebehoren** (zie blz. 41)

behoort niet tot het leveringspakket

- Verlengstuk 25 mm #13595000
- verlengset 22 mm (bij geringe inbouwdiepte)

 **Reinigen** (zie blz. 42)

 **Bediening** (zie blz. 35)

 **Keurmerk** (zie blz. 48)

Storing	Oorzaak	Oplossing
Bediening zwaar	- Kardoes defect of verkalkt	- Kardoes uitwisselen
Mengkraan lekt	- Kardoes defect	- Kardoes uitwisselen
Warmwater temperatuur te laag, geen koud water. Doorstroomtoestel springt aan wanneer koud water gekozen is.	- Heetwaterbegrenzer verkeerd ingesteld - Kruisstroom	- Heetwaterbegrenzer instellen - Kardoes uitwisselen



Sikkerhedsanvisninger

- △ Ved monteringen skal der bruges handsker for at undgå kvæstelser og snitsår.
- △ Produktet må kun bruges til bade-, hygiejne og kropsrengøringsformål.
- △ Større trykforskel mellem koldt og varmt vand bør udjævnes.

Monteringsanvisninger

- Før monteringen skal produktet kontrolleres for transportskader. Efter monteringen godkendes transportskader eller skader på overfladen ikke længere.
- Ledningerne og armaturerne skal monteres, skylles og kontrolleres iht. de gældende standarder.
- Installationsbestemmelserne, der gælder i det enkelte land, skal overholdes.

Tekniske data

Driftstryk:	max. 1 MPa
Anbefalet driftstryk:	0,1 - 0,5 MPa
Prøvetryk:	1,6 MPa (1 MPa = 10 bar = 147 PSI)
Varmtvandstemperatur:	max. 70°C
Anbefalet varmtvandstemperatur:	65°C
Termisk desinfektion:	max. 70°C / 4 min
Produktet er udelukkende beregnet til drikkevand!	

Symbolbeskrivelse



Der må ikke benyttes eddikesyreholdig silikone!



Forindstilling (se s. 34)

Indstilling af varmvandsbegrænsningen. I forbindelse med gennemstrømningsvandvarmere anbefaler vi ikke en varmvandsspærre.



Målene (se s. 36)



Gennemstrømningsdiagram (se s. 37)

fri gennemstrømning



Reserve dele (se s. 38)

- XXX = Overflade
- 000 = Krom
- 090 = Krom/Guld Optic
- 140 = Brushed Bronze
- 340 = Brushed Black Chrome
- 400 = Hvid/Krom
- 670 = Matt Black
- 700 = Matt White
- 990 = Polished Gold-Optic



Specialtilbehør (se s. 41)

ikke med i leveringsomfang

- Forlængersæt 25 mm #13595000
- Forlænger 22 mm (ved for stor indbygningsdybde)



Rengøring (se s. 42)



Brugsanvisning (se s. 35)



Godkendelse (se s. 48)

Fejl	Årsag	Hjælp
Grebet går trægt	- Kartusche defekt, tilkalket	- Udskift kartusche
Armaturet drypper	- Defekt kartusche	- Udskift kartusche
For lav varmtvandstemperatur. Ingen koldt vand. Vandvarmeren starter, når der åbnes for det kolde vand.	- Varmtvandsbegrænsningen er forkert indstillet - Kryds-flow	- Indstil varmtvandsbe-grænsningen - Udskift kartusche



Avisos de segurança

- ⚠ Durante a montagem devem ser utilizadas luvas de protecção, de modo a evitar ferimentos resultantes de entalamentos e de cortes.
- ⚠ O produto só pode ser utilizado para fins de higiene pessoal.
- ⚠ Grandes diferenças entre as pressões das águas quente e fria devem ser compensadas.

Avisos de montagem

- Antes da montagem deve-se controlar o produto relativamente a danos de transporte. Após a montagem não são aceites quaisquer danos de transporte ou de superfície.
- As tubagens e a torneira têm que ser montadas, enxaguadas e verificadas de acordo com as normas em vigor.
- A prescrições de instalação válidas nos respetivos países devem ser respeitadas.

Dados Técnicos

Pressão de funcionamento:	max. 1 MPa
Pressão de func. recomendada:	0,1 - 0,5 MPa
Pressão testada:	1,6 MPa (1 MPa = 10 bar = 147 PSI)
Temperatura da água quente:	max. 70 °C
Temp. água quente recomendada:	65 °C
Desinfecção térmica:	max. 70 °C / 4 min

Este produto foi única e exclusivamente concebido para água potável!

Descrição do símbolo



Não utilizar silicone que contenha ácido acético!



Afinação (ver página 34)

Ajuste do limitador de água quente. Em combinação com um esquentador, não é recomendável o uso de um bloqueio de água quente.



Medidas (ver página 36)



Fluxograma (ver página 37)

caudal livre



Peças de substituição (ver página 38)

XXX = Acabamentos
 000 = Cromado
 090 = Cromado/Ouro Ótica
 140 = Brushed Bronze
 340 = Brushed Black Chrome
 400 = Branco/Cromado
 670 = Matt Black
 700 = Matt White
 990 = Polished Gold-Optic



Acessórios especiais (ver página 41)

não incluído no volume de fornecimento

- Crescente 25 mm #13595000
- Crescente 22 mm (quando instalado demasiado longe da parede)



Limpeza (ver página 42)



Funcionamento (ver página 35)



Marca de controlo (ver página 48)

Falha	Causa	Solução
Misturadora perra	- Cartucho defeituoso, calcificado	- Substituir o cartucho
Misturadora a pingar	- Cartucho defeituoso	- Substituir o cartucho
Temperatura da água quente muito baixa, sem água fria. O esquentador dispara quando a água fria está seleccionada.	- O limitador de temperatura está incorrectamente colocado - Fluxo cruzado	- Regular o limitador de temperatura - Substituir o cartucho



Wskazówki bezpieczeństwa

- △ Aby uniknąć zranień na skutek zgniecenia lub przecięcia, podczas montażu należy nosić rękawice ochronne.
- △ Produkt może być używany tylko do kąpieli, higieny i czyszczenia ciała.
- △ Znaczne różnice ciśnień na dopływach ciepłej i zimnej wody muszą zostać wyrównane.

Wskazówki montażowe

- Przed montażem należy skontrolować produkt pod kątem szkód transportowych. Po montażu nie widać żadnych szkód transportowych ani szkód na powierzchni.
- Przewody i armatura muszą być montowane, płukane i kontrolowane według obowiązujących norm.
- Należy przestrzegać wytycznych instalacyjnych obowiązujących w danym kraju.

Dane techniczne

Ciśnienie robocze:	maks. 1 MPa
Zalecane ciśnienie robocze:	0,1 - 0,5 MPa
Ciśnienie próbne:	1,6 MPa
	(1 MPa = 10 bary = 147 PSI)
Temperatura wody gorącej:	maks. 70 °C
Zalecana temperatura wody gorącej:	65 °C
Dezynfekcja termiczna:	maks. 70 °C / 4 min
Produkt przeznaczony wyłącznie do wody pitnej!	

Opis symbolu



Nie stosować silikonów zawierających kwas octowy!



Ustawianie (patrz strona 34)

Ustawianie ogranicznika ciepłej wody. Używanie ogranicznika temperatury wody w połączeniu z przepływowym podgrzewaczem wody nie jest zalecane.



Wymiary (patrz strona 36)



Schemat przepływu

(patrz strona 37)

swobodny przepływ



Części serwisowe (patrz strona 38)

XXX = Kody kolorów

000 = Chrom

090 = Chrom/Złoty Szlachetna

140 = Brushed Bronze

340 = Brushed Black Chrome

400 = Biały/Chrom

670 = Matt Black

700 = Matt White

990 = Polished Gold-Optic



Wyposażenie specjalne

(patrz strona 41)

Nie jest częścią dostawy

- Przedłużka 25 mm #13595000
- Rozeta maskująca 22 mm (przy małej głębokości zabudowy)



Czyszczenie (patrz strona 42)



Obsługa (patrz strona 35)



Znak jakości (patrz strona 48)

Usterka

Przyczyna

Pomoc

Uchwyt armatury pracuje z wysiłkiem

- Uszkodzony wkład, zakamieniony

- Wymiana wkładu

Armatura cieknie

- Uszkodzony wkład

- Wymiana wkładu

Za niska temperatura ciepłej wody, brak zimnej wody. Przepływowo podgrzewacz wody uruchamia się, gdy wybiera się zimną wodę.

- Niewłaściwe ustawienie ogranicznika ciepłej wody

- Ustawić ogranicznik ciepłej wody

- Przepływ krzyżowy

- Wymiana wkładu





Bezpečnostní pokyny

- △ Pro zabránění řezným zraněním a pohmožděninám je nutné při montáži nosit rukavice.
- △ Produkt smí být používán pouze ke koupání a za účelem tělesné hygieny.
- △ Je nutné vyrovnat velké rozdíly tlaku mezi přípoji studené a teplé vody.

Pokyny k montáži

- Před montáží je třeba produkt zkontrolovat, zda nebyl při transportu poškozen. Po zabudování nebudou uznány žádné škody způsobené transportem nebo poškození povrchu.
- Vedení a armatura musí být namontovány, propláchnuty a otestovány podle platných norem.
- Je třeba dodržovat montážní pravidla platné v dané zemi.

Technické údaje

Provozní tlak: max. 1 MPa
 Doporučený provozní tlak: 0,1 - 0,5 MPa
 Zkušební tlak: 1,6 MPa

(1 MPa = 10 bar = 147 PSI)

Teplota horké vody: max. 70 °C
 Doporučená teplota horké vody: 65 °C
 Tepelná desinfekce: max. 70 °C / 4 min

Výrobky Hansgrohe jsou vhodné pro přímý kontakt s pitnou vodou.

Popis symbolů



Nepoužívat silikon s obsahem kyseliny octové!



Nastavení (viz strana 34)

Nastavení omezovače teplé vody. Ve spojení s průtokovým ohřívačem se použití uzávěru teplé vody nedoporučuje.



Rozměry (viz strana 36)



Diagram průtoku (viz strana 37)

volný průtok



Servisní díly (viz strana 38)

XXX = Kód povrchové úpravy

000 = Chrom

090 = Chrom/Zlato Oc'el

140 = Brushed Bronze

340 = Brushed Black Chrome

400 = Bílá/Chrom

670 = Matt Black

700 = Matt White

990 = Polished Gold-Optic



Zvláštní příslušenství

(viz strana 41)

není součástí dodávky

- prodloužení 25 mm #13595000

- prodloužení 22 mm (při malé hloubce zabudování)



Čištění (viz strana 42)



Ovládání (viz strana 35)



Zkušební značka (viz strana 48)

Porucha	Příčina	Odstranění
Armatura jde ztěžka	- Kartuše je vadná, zanesená vodním kamenem	- Kartuši vyměnit
Armatura odkapává	- Kartuše je vadná	- Kartuši vyměnit
nízká teplota teplé vody studená voda naskočí, když se navolí studená voda	- Špatně nastavená zarážka pro teplou vodu - Křížení toků	- Seřadit zarážku pro teplou vodu - Kartuši vyměnit



Bezpečnostné pokyny

- △ Pri montáži musíte nosiť rukavice, aby ste predišli pomliaždeninám a rezným poraneniam.
- △ Produkt sa smie používať len na kúpanie a telesnú hygienu.
- △ Veľké rozdiely v tlaku medzi prípojkami studenej a teplej vody musia byť vyrovnané.

Pokyny pre montáž

- Pred montážou musíte produkt skontrolovať, či nebol počas transportu poškodený. Po zabudovaní nebudú uznané žiadne škody spôsobené transportom alebo poškodenia povrchu.
- Ledningarna och blandaren måste monteras, spolás igenom och kontrolleras enligt de gällande normerna.
- Je potrebné dodržiavať smernice o inštalácii, ktoré sú práve teraz platné v krajinách.

Technické údaje

Prevádzkový tlak: max. 1 MPa
 Doporučený prevádzkový tlak: 0,1 - 0,5 MPa
 Skúšobný tlak: 1,6 MPa
 (1 MPa = 10 bar = 147 PSI)

Teplota teplej vody: max. 70 °C
 Doporučená teplota teplej vody: 65 °C
 Termická dezinfekcia: max. 70 °C / 4 min
 Výrobok je koncipovaný výhradne pre pitnú vodu!

Popis symbolov



Nepoužívať silikón s obsahom kyseliny octovej!



Nastavenie (viď strana 34)

Nastavenie obmedzenia teplej vody. V spojení s prietokovými ohrievačmi sa neodporúča použitie obmedzovača teplej vody.



Rozmery (viď strana 36)



Diagram prietoku (viď strana 37)

volný prietok



Servisné diely (viď strana 38)

XXX = Farebné označenie
 000 = Chróm
 090 = Chróm/Zlato Ocel
 140 = Brushed Bronze
 340 = Brushed Black Chrome
 400 = Biela/Chróm
 670 = Matt Black
 700 = Matt White
 990 = Polished Gold-Optic



Zvláštne príslušenstvo

(viď strana 41)

nie je súčasťou dodávky

- Predĺženie 25 mm #13595000
- Predĺženie 22 mm (pri malej montážnej hĺbke)



Čistenie (viď strana 42)



Obsluha (viď strana 35)



Osvedčenie o skúške

(viď strana 48)

Porucha	Príčina	Pomoc
Armatúra "chodí" ťažko	- Kartúša je poškodená, vápenaté usadeniny	- Vymeniť kartušu
Z armatúry kvapká voda	- Kartúša je poškodená	- Vymeniť kartušu
Málo teplá voda, žiadna studená voda, prietokový ohrievač naskočí, keď sa navolí studená voda.	- Nesprávne nastavená zarážka na teplú vodu - Kríženie tokov	- Nastavenie zarážky na teplú vodu - Vymeniť kartušu



安全技巧

- △ 装配时为避免挤压和切割受伤，必须戴上手套。
- △ 本产品只允许作为洗浴、卫生和洁身之用。
- △ 冷热水管间过大的压力差必须予以平衡。

安装提示

- 安装前必须检查产品是否受到运输损害。安装后将不认可运输损害或表面损伤。
- 管道和阀门必须根据通用标准进行安装、冲洗和检查。
- 请遵守当地国家现行的安装规定。

技术参数

工作压力:	最大 1 MPa
推荐工作压力:	0,1 - 0,5 MPa
测试压强:	1,6 MPa
	(1 MPa = 10 bar = 147 PSI)
热水温度:	最大 70°C
推荐热水温度:	65°C
热力消毒:	最大 70°C / 4 分钟

该产品专为饮用水设计！

符号说明



请勿使用含有乙酸的硅胶！

调节 (参见第页 34)

热水温度调节。如果使用即热式喷头，则不建议安装热水阀门。



大小 (参见第页 36)



流量示意图 (参见第页 37)
时的流速



备用零件 (参见第页 38)

XXX = 颜色代码
 000 = 镀铬
 090 = 镀铬/黑色
 140 = Brushed Bronze
 340 = Brushed Black Chrome
 400 = 白色/镀铬
 670 = Matt Black
 700 = Matt White
 990 = Polished Gold-Optic



选装附件 (参见第页 41)
不在供货范围内

- 加长 25 mm #13595000
- 加长件22mm (墙壁不够深时)



清洗 (参见第页 42)



操作 (参见第页 35)



检验标记 (参见第页 48)

问题	原因	补救
龙头不灵活	- 阀芯损坏, 结垢	- 更换阀芯
龙头滴水	- 阀芯损坏	- 更换阀芯
热水温度过低, 没有冷水。选择冷水时, 热水器启动。	- 温度限制器设置错误 - 交叉流动	- 设置温度限制器 - 更换阀芯



Указания по технике безопасности

- △ Во время монтажа следует надеть перчатки во избежание прищемления и порезов.
- △ Изделие разрешается использовать только в гигиенических целях: для принятия ванны и личной гигиены.
- △ донного клапа. Перед установкой смесителя необходимо регулировочными кранами выровнять авление холодной и горячей воды при помощи вентмлей регулирующих подачу воды в квартиру.

Указания по монтажу

- Перед монтажом следует проверить изделие на предмет повреждений при перевозке. После монтажа претензии о возмещении ущерба за повреждения при перевозке или повреждения поверхностей не принимаются.
- Трубы и арматура должны быть установлены, промыты и проверены в соответствии с действующими нормами.
- Необходимо соблюдать требования по монтажу, действующие в соответствующих странах.

Технические данные

Рабочее давление: не более. 1 МПа
 Рекомендуемое рабочее давление: 0,1 - 0,5 МПа
 Давлении: 1,6 МПа
 (1 МПа = 10 bar = 147 PSI)
 Температура горячей воды: не более. 70 °С
 Рекомендуемая темп. гор. воды: 65 °С
 Термическая дезинфекция: не более. 70 °С / 4 мин
 Изделие предназначено исключительно для питьевой воды!

Описание символов



Не применяйте силикон, содержащий уксусную кислоту.



Подгонка (см. стр. 34)

Регулировка ограничителя горячей воды. В сочетании с проточными нагревателями не рекомендуется использовать блокировку воды.



Размеры (см. стр. 36)



Схема потока (см. стр. 37)

свободное истечение



Комплект (см. стр. 38)

XXX = Цветная кодировка
 000 = Хром
 090 = Хром/Глянцевое Золото
 140 = Brushed Bronze
 340 = Brushed Black Chrome
 400 = Белый/Хром
 670 = Matt Black
 700 = Matt White
 990 = Polished Gold-Optic



Специальные принадлежности (см. стр. 41)

не включено в объем поставки!

- Удлинение 25 мм #13595000
- Удлинение 22 мм (при малой глубине установки)



Очистка (см. стр. 42)



Эксплуатация (см. стр. 35)



Знак технического контроля (см. стр. 48)

Неисправность	Причина	Устранение неисправности
Арматура работает с усилием	- Картридж неисправен, засорение накипью	- Замените картридж
Арматура протекает	- Картридж неисправен	- Замените картридж
Слишком низкая температура горячей воды. Проточный нагреватель запускается при выборе холодной воды.	- Ограничение горячей воды отрегулировано неправильно - Перекрестный поток	- Отрегулируйте ограничение горячей воды - Замените картридж



Turvallisuusohjeet

- △ Asennuksessa on käytettävä käsiineitä puristumien ja viiltojen aiheuttamien tapaturmien estämiseksi.
- △ Tuotetta saa käyttää ainoastaan kylpy-, hygienia- ja puhdistustarkoituksiin.
- △ Suuret paine-erot kylmä- ja kuumavesiliitäntöjen välillä on tasattava.

Asennusohjeet

- Ennen asennusta on tarkastettava tuotteen mahdolliset kuljetusvahingot. Asennuksen jälkeen kuljetus- ja pintavaurioita ei hyväksytä.
- Putket ja hana on asennettava, huuhdeltava ja tarkastettava voimassa olevien standardien mukaisesti.
- Jokaisessa maassa on noudatettava siellä päteviä asennusohjeita.

Tekniset tiedot

Käyttöpaine:	maks. 1 MPa
Suosittelut käyttöpaine:	0,1 - 0,5 MPa
Koestuspaine:	1,6 MPa
	(1 MPa = 10 bar = 147 PSI)
Kuuman veden lämpötila:	maks. 70 °C
Kuuman veden suosituslämpötila:	65 °C
Lämpödesinfektio:	maks. 70 °C / 4 min

Tuote on suunniteltu käytettäväksi ainoastaan juomaveden kanssa!

Merkin kuvaus



Älä käytä etikkahappopitoista silikonia!

Säättö (katso sivu 34)

Lämpötilan rajoittimen säätäminen. Emme suosittele käyttämään lämpötilan rajoitinta vedenlämmittimen (läpivirtauskuumennin) yhteydessä.



Mitat (katso sivu 36)



Virtausdiagrammi (katso sivu 37)

vapaa läpivirtaus



Varaosat (katso sivu 38)

XXX = Värikoodaus

000 = Kromi

090 = Kromi/Kultaoptiikka

140 = Brushed Bronze

340 = Brushed Black Chrome

400 = Valkoinen/Kromi

670 = Matt Black

700 = Matt White

990 = Polished Gold-Optic



Erityisvaruste (katso sivu 41)

ei kuulu toimitukseen

- Pidennys 25 mm #13595000

- Pidennys 22 mm (pienemmällä asennussyvydellä)



Puhdistus (katso sivu 42)



Käyttö (katso sivu 35)



Koestusmerkki (katso sivu 48)

Häiriö

Syy

Toimenpide

Hana on raskaskäyttöinen	- Patruuna rikki, kalkkikerrostumia	- Vaihda patruuna
Hanasta tippuu vettä	- Patruuna rikki	- Vaihda patruuna
Lämminveden lämpötila liian alhainen, ei kylmää vettä. Läpivirtauskuumennin käynnistyy kylmää vettä otettaessa.	- Lämminveden rajoitin väärin säädetty	- Säädä lämminveden rajoitin
	- Ristiinvirtaus	- Vaihda patruuna



Säkerhetsanvisningar

- △ Handskar ska bäras under monteringsarbetet så att man kan undvika kläm- och skärskador.
- △ Produkten får bara användas till kroppshygien med bad och dusch.
- △ Stora tryckskillnader mellan anslutningarna för varmt och kallt vatten måste utjämnas.

Monteringsanvisningar

- Det måste undersökas om produkten har transportskador innan den monteras. Efter monteringen accepteras inga transport- eller ytskiktsskador.
- Ledningarna och blandaren måste monteras, spolas igenom och kontrolleras enligt de gällande normerna.
- De installationsriktlinjer som gäller i länderna ska följas.

Tekniska data

Driftstryck:	max. 1 MPa
Rek. driftstryck:	0,1 - 0,5 MPa
Tryck vid provtryckning:	1,6 MPa (1 MPa = 10 bar = 147 PSI)
Varmvattentemperatur:	max. 70 °C
Rek. varmvattentemp.:	65 °C
Termisk desinfektion:	max. 70 °C / 4 min

Produkten är enbart avsedd för dricksvatten!

Symbolförklaring



Använd inte silikon som innehåller ättiksyra!



Justering (se sidan 34)

Ställa in varmvattenregleringen. Tillsammans med varmvattenberedare rekommenderas inte en varmvattenspär.



Måtten (se sidan 36)



Flödesschema (se sidan 37)

fri genomströmning



Reservdelar (se sidan 38)

XXX = Färgkodning

000 = Krom

090 = Krom/Guld-Optik

140 = Brushed Bronze

340 = Brushed Black Chrome

400 = Vit/Krom

670 = Matt Black

700 = Matt White

990 = Polished Gold-Optic



Specialtillbehör (se sidan 41)

medföljer ej leveransen

- Förlängning 25 mm #13595000

- Förlängning 22 mm (vid litet monteringsdjup)



Rengöring (se sidan 42)



Hantering (se sidan 35)



Testsigill (se sidan 48)

Störning

Orsak

Åtgärd

Blandare är trög	- Patron defekt, förkalkad	- Byt ut patron
Blandare droppar	- Patron defekt	- Byt ut patron
För låg varmvattentemperatur, inget kallvatten. Varmvattenberedaren slår på när kallvatten väljs.	- Varmvattenreglering felaktigt inställd - Korsflöde	- Ställ in varmvattenreglering - Byt ut patron



Saugumo technikos nurodymai

- △ Apsaugai nuo užspaudimo ir įsijpavimo montavimo metu mūvėkite pirštines.
- △ Gaminys turi būti naudojamas tik maudymuisi, kūno higienai ir švarai palaikyti.
- △ Turi būti išlyginti šalto ir karšto slėgio nelygumai.

Montavimo instrukcija

- Prieš montuojant būtina patikrinti, ar gaminys nebuvo pažeistas transportavimo metu. Sumontavus pretenzijos dėl transportavimo ir paviršiaus pažeidimų nepriimamos.
- Vamzdžiai ir sujungimai turi būti montuojami, plaujami ir tikrinami pagal galiojančias normas.
- Laikykitės atitinkamoje šalyje galiojančių direktyvų dėl įrengimo.

Techniniai duomenys

Darbinis slėgis: ne daugiau kaip 1 MPa
 Rekomenduojamas slėgis: 0,1 - 0,5 MPa
 Bandomasis slėgis: 1,6 MPa
 (1 MPa = 10 barų = 147 PSI)
 Karšto vandens temperatūra: ne daugiau kaip 70 °C
 Rekomenduojama karšto vandens temperatūra: 65 °C
 Terminis dezinfekavimas: ne daugiau kaip 70 °C / 4 min
 Produktas skirtas tik geriamajam vandeniui!

Simbolio aprašymas



Nenaudokite silikono, kurio sudėtyje yra acto rūgšties!



Reguliuavimas (žr. psl. 34)

Karšto vandens ribojimas. Kartu su cirkuliaciniais šildytuvais nerekomenduojama naudoti karšto vandens blokavimo įtaisų.



Įšmatavimai (žr. psl. 36)



Pralaidumo diagrama (žr. psl. 37)

laisvas vandens pralaidumas



Atsarginės dalys (žr. psl. 38)

XXX = Spalvos
 000 = Chrom
 090 = Chrominė/Aukso Optika
 140 = Brushed Bronze
 340 = Brushed Black Chrome
 400 = Balta/Chrom
 670 = Matt Black
 700 = Matt White
 990 = Polished Gold-Optic



Specialūs priedai (žr. psl. 41)

nėra pridama

- Ilgiklis 25 mm #13595000
- Ilgiklis 22 mm (esant nepakankamam sienos gyliui)



Valymas (žr. psl. 42)



Eksploatacija (žr. psl. 35)



Bandymo pažyma (žr. psl. 48)

Gedimas	Priežastis	Priemonė
Sunkiai sukiojama rankenėlė	- Kasetė pažeista, užkalkėjusi	- Pakeisti kasetę
Maišytuvus praleidžia vandenį	- Kasetė pažeista	- Pakeisti kasetę
Per maža karšto vandens temperatūra, nėra šalto vandens. Momentinis pašildytojas pradeda veikti, kai naudojamas šalta vanduo	- Neteisingai nustatytas karšto vandens ribotuvas - Kryžminė srovė	- Nustatyti karšto vandens ribotuvą - Pakeisti kasetę



Sigurnosne upute

- △ Prilikom montaže se radi sprječavanja prignječenja i posjekotina moraju nositi rukavice.
- △ Proizvod se smije primjenjivati samo za kupanje, tuširanje i osobnu higijenu.
- △ Velika razlika u pritisku između vruće i hladne vode mora biti izbalansirana.

Upute za montažu

- Prije montaže mora se provjeriti je li proizvod oštećen prilikom transporta. Nakon ugradnje se ne priznaju nikakve reklamacije koje se odnose na površinska i transportna oštećenja.
- Cijevi i armatura moraju biti postavljeni, isprani i testirani prema važećim normama.
- Obvezno se moraju uvažiti propisi o instalacijama koji vrijede u dotičnoj zemlji.

Tehnički podatci

Najveći dopušteni tlak:	tlak 1 MPa
Preporučeni tlak:	0,1 - 0,5 MPa
Probni tlak:	1,6 MPa
	(1 MPa = 10 bar = 147 PSI)
Temperatura vruće vode:	tlak 70°C
Preporučena temperatura vruće vode:	65°C
Termička dezinfekcija:	tlak 70°C / 4 min
Proizvod je koncipiran isključivo za pitku vodu!	

Opis simbola



Nemojte koristiti silikon koji sadrži octenu kiselinu!



Regulacija (pogledaj stranicu 34)

Namještanje limitera tople vode. U kombinaciji s protočnim bojlerima nije preporučljiva primjena sustava za blokiranje dotoka tople vode.



Mjere (pogledaj stranicu 36)



Dijagram protoka

(pogledaj stranicu 37)
slobodan protok



Rezervni djelovi

(pogledaj stranicu 38)

XXX = Boje
000 = Krom
090 = Optika Krom/Zlato
140 = Brushed Bronze
340 = Brushed Black Chrome
400 = Bijela/Krom
670 = Matt Black
700 = Matt White
990 = Polished Gold-Optik



Posebni pribor

(pogledaj stranicu 41)

Nije sadržano u isporuci!

- Produljenje 25 mm #13595000
- Produljenje 22 mm (kod manje dubine ugradnje)



Čišćenje (pogledaj stranicu 42)



Upotreba (pogledaj stranicu 35)



Oznaka testiranja

(pogledaj stranicu 48)

Greška

Uzrok

Otklanjanje

Ručica se zaglavila

- Neispravan uložak Taloženje kamenca

- Zamijenite uložak

Slavina kaplje

- Neispravan uložak

- Zamijenite uložak

Preniska temperatura vruće vode, nedostatak hladne vode. Protočni

- Limiter vruće vode nije dobro podešen

- Podesite limiter vruće vode

bojler se pali pri podešenoj funkciji za protok hladne vode

- Križni tok vode

- Zamijenite uložak





Güvenlik uyarıları

- △ Montaj esnasında ezilme ve kesilme gibi yaralanmaları önlemek için eldiven kullanılmalıdır.
- △ Ürün yalnızca banyo, hijyen ve beden temizliği amaçları doğrultusunda kullanılabilir.
- △ Sıcak ve soğuk su bağlantıları arasında büyük basınç farklılıkları varsa, bu basınç farklılıklarının dengelenmesi gerekir.

Montaj açıklamaları

- Montaj işleminden önce ürün nakliye hasarları yönünden kontrol edilmelidir. Montaj işleminden sonra nakliye veya yüzey hasarları için sorumluluk üstlenilmemektedir.
- Boruların ve armatürün montajı, yıkanması ve kontrolü geçerli normlara göre yapılmalıdır.
- Ülkelerde geçerli kurulum yönetmeliklerine riayet edilmelidir.

Teknik bilgiler

İşletme basıncı:	azami 1 MPa
Tavsiye edilen işletme basıncı:	0,1 - 0,5 MPa
Kontrol basıncı:	1,6 MPa (1 MPa = 10 bar = 147 PSI)
Sıcak su sıcaklığı:	azami 70 °C
Tavsiye edilen su ısı:	65 °C
Termik dezenfeksiyon:	azami 70 °C / 4 dak

Ürün sadece şebeke suyu için tasarlanmıştır!

Simge açıklaması

 Asetik asit içeren silikon kullanmayın!

 **Ayarlama** (bakınız sayfa 34)

Sıcak su sınırlamasının ayarlanması. Sıcak su kilitinin sürekli ısıtıcıyla kullanılması tavsiye edilmez.

 **Ölçüleri** (bakınız sayfa 36)

 **Akış diyagramı** (bakınız sayfa 37)
serbest akış

 **Yedek Parçalar** (bakınız sayfa 38)

XXX = Renkler
000 = Krom
090 = Krom/Altın-Optik
140 = Brushed Bronze
340 = Brushed Black Chrome
400 = Beyaz/Krom
670 = Matt Black
700 = Matt White
990 = Polished Gold-Optic

 **Özel aksesuarlar** (bakınız sayfa 41)

Teslimat kapsamına dahil değildir

• Uzatma 25 mm #13595000

• Uzatma 22 mm (montaj derinliği düşükken)

 **Temizleme** (bakınız sayfa 42)

 **Kullanımı** (bakınız sayfa 35)

 **Kontrol işareti** (bakınız sayfa 48)

arıza	sebebe	yardım
Batarya kullanımı ağırlaşıyor	- Kartuş Bozulmuş ve kireçlenmiş olabilir	- Kartuşu değiştirin
Batarya su damlatıyor	- Kartuş bozuk olabilir	- Kartuşu değiştirin
Sıcak su sıcaklığı çok düşük, soğuk su yok. Soğuk su seçilince şofben çalışmaya başlıyor.	- Isı limitleyici düzgün çalışmıyor - Çapraz akış	- Isı limitleyiciyi yeniden ayarlayın - Kartuşu değiştirin



Instrucțiuni de siguranță

- ⚠ La montare utilizați mănuși pentru evitarea contuziunilor și tăierii mâinilor.
- ⚠ Produsul poate fi utilizat doar pentru spălarea, menținerea igienei și curățarea corpului.
- ⚠ Diferențele de presiune mari între alimentarea cu apă rece și apă caldă trebuie echilibrate.

Instrucțiuni de montare

- Înainte de instalare verificați, dacă produsul prezintă deteriorări de transport. După instalare garanția nu acoperă deteriorările de transport și cele de suprafață.
- Conductele și bateriile trebuie montate, spălate și verificate conform normelor în vigoare.
- Respectați reglementările referitoare la instalare valabile în țara respectivă.

Date tehnice

Presiune de funcționare: max. 1 MPa
 Presiune de funcționare recomandată: 0,1 - 0,5 MPa
 Presiune de verificare: 1,6 MPa
 (1 MPa = 10 bar = 147 PSI)

Temperatura apei calde: max. 70°C
 Temperatura recomandată a apei calde: 65°C
 Dezinfecție termică: max. 70°C / 4 min

Produsul este destinat exclusiv pentru apă potabilă.

Descrierea simbolurilor



Nu utilizați silikon cu conținut de acid acetic!



Reglare (vezi pag. 34)

Reglarea limitatorului de apă caldă. Nu se recomandă folosirea unui limitator de apă caldă în combinație cu un boiler instant.



Dimensiuni (vezi pag. 36)



Diagrama de debit (vezi pag. 37)
debit cu curgere liberă



Piese de schimb (vezi pag. 38)

XXX = Coduri de culori
 000 = Crom
 090 = Crom/Auriu Optic
 140 = Brushed Bronze
 340 = Brushed Black Chrome
 400 = Alb/Crom
 670 = Matt Black
 700 = Matt White
 990 = Polished Gold-Optic



Accesorii opționale (vezi pag. 41)

nu este inclus în setul livrat

- Prolungitor 25 mm #13595000
- Prolungitor 22 mm (în cazul montării la adâncime mică)



Curățare (vezi pag. 42)



Utilizare (vezi pag. 35)



Certificat de testare (vezi pag. 48)

Deranjament

Cauza

Măsurile de remediere

Bateria se mișcă dificil	- Cartuș defect din cauza depunerilor de calcar	- Schimbați cartușul.
Bateria picură	- Cartuș defect	- Schimbați cartușul.
Temperatura apei este prea mică, nu este apă rece. Boilerul instant pornește când se dă drumul la apa rece	- Limitarea temperaturii apei calde setată incorect. - Curgere încrucișată (apa rece în intră în conducta de apă caldă și invers)	- Setați limitarea temperaturii apei calde. - Schimbați cartușul.





Υποδειξεις ασφαλείας

- ⚠ Για να αποφύγετε τραυματισμούς κατά τη συναρμολόγηση πρέπει να φοράτε γάντια.
- ⚠ Το προϊόν επιτρέπεται να χρησιμοποιείται μόνο σαν μέσο λουτρού, υγιεινής και καθαρισμού του σώματος.
- ⚠ Οι διαφορές της πίεσης μεταξύ της σύνδεσης κρύου και ζεστού νερού θα πρέπει να αντισταθμίζονται.

Οδηγίες συναρμολόγησης

- Πριν τη συναρμολόγηση πρέπει να εξεταστεί το προϊόν για ζημιές μεταφοράς. Μετά την εγκατάσταση δεν αναγνωρίζονται ζημιές από τη μεταφορά ή επιφανειακές ζημιές.
- Οι σωλήνες και η μπαταρία πρέπει να τοποθετηθούν σύμφωνα με τα ισχύοντα πρότυπα, να τεθούν υπό πίεση και να δοκιμαστούν.
- Θα πρέπει να τηρούνται οι οδηγίες εγκατάστασης που ισχύουν σε κάθε κράτος.

Τεχνικά Χαρακτηριστικά

Λειτουργία πίεσης: έως 1 MPa
 Συνιστώμενη λειτουργία πίεσης: 0,1 - 0,5 MPa
 Πίεση ελέγχου: 1,6 MPa
(1 MPa = 10 bar = 147 PSI)
 Θερμοκρασία ζεστού νερού: έως 70 °C
 Συνιστώμενη θερμοκρασία ζεστού νερού: 65 °C
 Θερμική απολύμανση: έως 70 °C / 4 min
 Το προϊόν έχει σχεδιαστεί αποκλειστικά για πόσιμο νερό!

Περιγραφή συμβόλων



Μην χρησιμοποιείτε σιλικόνη που περιέχει οξικό οξύ!



Ρύθμιση (βλ. Σελίδα 34)

Ρύθμιση του δοσομετρητή ζεστού νερού. Δεν συνιστάται η διάταξη φραγής ζεστού νερού σε συνδυασμό με ταχυθερμοσίφωνα.



Διαστάσεις (βλ. Σελίδα 36)



Διάγραμμα ροής (βλ. Σελίδα 37)

Ελεύθερη ροή



Ανταλλακτικά (βλ. Σελίδα 38)

XXX = Χρώματα
 000 = Επιχρωμιωμένο
 090 = Επιχρωμιωμένο/Οπτική Χρυσού
 140 = Brushed Bronze
 340 = Brushed Black Chrome
 400 = Λευκό/Επιχρωμιωμένο
 670 = Matt Black
 700 = Matt White
 990 = Polished Gold-Optic



Ειδικά αξεσουάρ (βλ. Σελίδα 41)

δεν περιλαμβάνεται στον παραδοτέο εξοπλισμό

- Επιμήκυνση 25 mm #13595000
- Σωλήνας επιμήκυνσης 22 mm (σε μειωμένο βάθος τοποθέτησης)



Καθαρισμός (βλ. Σελίδα 42)



Χειρισμός (βλ. Σελίδα 35)



Σήμα ελέγχου (βλ. Σελίδα 48)

Βλάβη

Αιτία

Διόρθωση

Σκληρή μπαταρία (μείκτης)	- Ελαττωματικό φυσίγγιο, άλατα	- Αλλαγή φυσιγγίου
Η μπαταρία στάζει	- Ελαττωματικό φυσίγγιο	- Αλλαγή φυσιγγίου
Χαμηλή θερμοκρασία ζεστού νερού, καθόλου κρύο νερό. Ο ταχυθερμοσίφωνας ενεργοποιείται, όταν επιλέγεται το κρύο νερό.	- Λάθος ρύθμιση της περιοριστικής διάταξης ζεστού νερού - Σταυροειδής ροή	- Ρυθμίστε την περιοριστική διάταξη του ζεστού νερού - Αλλαγή φυσιγγίου





Varnostna opozorila

- ⚠ Pri montaži je treba nositi rokavice, da se preprečijo poškodbe zaradi zmečkanja ali urezov.
- ⚠ Ta izdelek se sme uporabljati le z namenom umivanja, vzdrževanja higiene in telesne nege.
- ⚠ Velike razlike v tlaku med priključkom za mrzlo in priključkom za toplo vodo je potrebno izravnati.

Navodila za montažo

- Pred montažo je treba izdelek preveriti glede morebitnih transportnih poškodb. Po vgradnji transportne ali površinske poškodbe ne bodo več priznane.
- Cevi in armaturo je treba montirati, izprati in preveriti po veljavnih standardih.
- Upoštevati je treba pravilnike o inštalacijah, ki veljajo v posamezni državi.

Tehnični podatki

Delovni tlak:	maks. 1 MPa
Priporočeni delovni tlak:	0,1 - 0,5 MPa
Preskusni tlak:	1,6 MPa (1 MPa = 10 bar = 147 PSI)
Temperatura tople vode:	maks. 70 °C
Priporočena temperatura tople vode:	65 °C
Termična dezinfekcija:	maks. 70 °C / 4 min
Proizvod je zasnovan izključno za sanitarno vodo!	

Opis simbola



Ne smete uporabiti silikona, ki vsebuje osetno kislino!



Justiranje (glejte stran 34)

Nastavitev omejevalnika tople vode. V povezavi s pretočnimi grelniki uporaba zapore tople vode ni priporočljiva.



Mere (glejte stran 36)



Diagram pretoka (glejte stran 37)

prost pretok



Rezervni deli (glejte stran 38)

XXX = Barve
 000 = Krom
 090 = Krom/Pozlačena
 140 = Brushed Bronze
 340 = Brushed Black Chrome
 400 = Bela/Krom
 670 = Matt Black
 700 = Matt White
 990 = Polished Gold-Optic



Poseben pribor (glejte stran 41)

Ni vključeno

- Podaljšek 25 mm #13595000
- Podaljšek 22 mm (če zid ni dovolj globok)



Čiščenje (glejte stran 42)



Upravljanje (glejte stran 35)



Preskusni znak (glejte stran 48)

Napaka

Vzrok

Pomoč

Težko premikanje armature	- Pokvarjen vložek, poapneno	- Zamenjajte vložek
Iz armature kaplja	- Pokvarjen vložek	- Zamenjajte vložek
Prenizka temperatura tople vode, ni mrzle vode. Pretočni grelnik se sproži, kadar izberete mrzlo vodo.	- Omejevalnik tople vode ni pravilno nastavljen - Križni tok	- Nastavite omejevalnik tople vode - Zamenjajte vložek



Ohutusjuhised

- △ Kandke paigaldamisel muljumis- ja löikevigastuste vältimiseks kindaid.
- △ Toodet tohib kasutada ainult pesemis-, hügieeni- ja kehahapustamiseesmärkidel.
- △ Kui külma ja kuuma vee ühenduste surve on väga erinev, tuleb need tasakaalustada.

Paigaldamisjuhised

- Enne paigaldamist tuleb toodet kontrollida transpordikahjustuste osas. Pärast paigaldamist ei tunnustata enam transpordi- või pinnakahjustuste kaebuseid.
- Voolikute ja segisti paigaldamisel, loputamisel ja kontrollimisel tuleb lähtuda kehtivatest normatiividest.
- Vastavas riigis kehtivaid paigalduseeskirju tuleb järgida.

Tehnilised andmed

Töörõhk	maks. 1 MPa
Soovitav töörõhk:	0,1 - 0,5 MPa
Kontrollsurve:	1,6 MPa (1 MPa = 10 baari = 147 PSI)
Kuuma vee temperatuur:	maks. 70 °C
Soovitav kuuma vee temperatuur:	65 °C
Termiline desinfitatsioon:	maks. 70 °C / 4 min
Toode on ette nähtud eranditult joogivee jaoks!	

Sümbolite kirjeldus



Ärge kasutage äädikhapet sisaldavat silikooni!



Reguleerimine (vt lk 34)

Sooja vee piirangu seadistamine. Ühenduses boileritega ei ole sooja vee blokeeringu soovitatav.



Mõõtude (vt lk 36)



Läbivooludiagramm (vt lk 37)

äravoolu surve



Varuosad (vt lk 38)

XXX = Värvid
 000 = Kroom
 090 = Kroom/Kuld Optik
 140 = Brushed Bronze
 340 = Brushed Black Chrome
 400 = Valge/Kroom
 670 = Matt Black
 700 = Matt White
 990 = Polished Gold-Optic



Spetsiaalne lisavarustus (vt lk 41)

ei sisaldu komplektis

- pikendus 25 mm #13595000
- pikendus 22 mm (kui sein ei ole piisavalt paks)



Puhastamine (vt lk 42)



Kasutamine (vt lk 35)



Kontrollsertifikaat (vt lk 48)

Rike	Põhjus	Lahendus
Segisti käib raskelt	- Tööelement on katkine, lubjastunud	- Vahetage tööelement
Segisti tilgub	- Tööelement on katkine	- Vahetage tööelement
Liiga madal sooja vee temperatuur, külma vett pole. Läbivoolu boiler hakkab tööle, kui on valitud külm vesi.	- Kuuma vee piirang valesti seatud - Ristvool	- Seadke kuuma vee piirang - Vahetage tööelement



Drošības norādes

- △ Montāžas laikā, lai izvairītos no saspiedumiem un iegriezumiem, nepieciešams nēsāt cimdus.
- △ Šo produktu drīkst izmantot tikai, lai mazgātos, higiēnai un ķermeņa tīrīšanai.
- △ Jāizlīdzina spiediena atšķirības starp aukstā un karstā ūdens pievadiem.

Norādījumi montāžai

- Pirms montāžas nepieciešams pārbaudīt, vai produktam transportēšanas laikā nav radušies bojājumi. Pēc iebūvēšanas bojājumi, kas radušies transportēšanas laikā, vai virsmas bojājumi netiek atzīti.
- Caurulvadi un armatūra ir jāuzstāda, jāizskalo un jāpārbauda saskaņā ar spēkā esošajiem standartiem.
- Jāievēro attiecīgās valstīs spēkā esošās montāžas prasības.

Tehniskie dati

Darba spiediens: maks. 1 MPa
 Ieteicamais darba spiediens: 0,1 - 0,5 MPa
 Pārbaudes spiediens: 1,6 MPa
 (1 MPa = 10 bar = 147 PSI)

Karstā ūdens temperatūra: maks. 70 °C
 Ieteicamā karstā ūdens temperatūra: 65 °C
 Termiskā dezinfekcija : maks. 70 °C / 4 min

Izstrādājums ir paredzēts tikai dzeramajam ūdenim!

Simbolu nozīme



Neizmantojot silikonu, kas satur etiķskābi!



Ieregulēšana (skat. lpp. 34)

Karsta ūdens ierobežotāja regulēšana. Kopā ar caurteces sildītājiem nav ieteicams izmantot ūdens bloķētāju.



Izmērus (skat. lpp. 36)



Caurplūdes diagramma (skat. lpp. 37)

brīva caurplūde



Rezerves daļas (skat. lpp. 38)

XXX = Krāsu kodi
 000 = Hroma
 090 = Hroma/Zelta
 140 = Brushed Bronze
 340 = Brushed Black Chrome
 400 = Balta/Hroma
 670 = Matt Black
 700 = Matt White
 990 = Polished Gold-Optic



Speciāli aksesuāri (skat. lpp. 41)

komplektā netiek piegādāts

- Pagarinājums 25 mm #13595000
- Pagarinājums 22 mm (ja iebūvēšanas dziļums nav pietiekams)



Tīrīšana (skat. lpp. 42)



Lietošana (skat. lpp. 35)



Pārbaudes zīme (skat. lpp. 48)

Traucējums

Iemesls

Bojājumu novēršana

Jaucējkrāns smagi grozāms	- Bojāta kartuša, aizkalķojusies	- Nomainīt kartušu
Jaucējkrāns pil	- Bojāta kartuša	- Nomainīt kartušu
Pārāk zema ūdens temperatūra, nav aukstā ūdens, izvēloties auksto ūdeni, sāk darboties caurteces sildītājs	- Nepareizi noregulāta karstā ūdens bloķēšana - Ūdens sajaukšanās	- Noregulēt karstā ūdens ierobežošanu - Nomainīt kartušu





Sigurnosne napomene

- △ Prilikom montaže se radi sprečavanja prignječenja i posekotina moraju nositi rukavice.
- △ Proizvod sme da se koristi samo za kupanje, tuširanje i ličnu higijenu.
- △ Velika razlika u pritisku između vruće i hladne vode mora biti izbalansirana.

Instrukcije za montažu

- Pre montaže se mora proveriti da li je proizvod oštećen pri transportu. Nakon ugradnje se ne priznaju nikakve reklamacije koje se odnose na površinska i transportna oštećenja.
- Vodovi i armatura moraju biti postavljeni, isprani i testirani prema važećim normama.
- Treba se pridržavati propisa koji u određenim zemljama važe za instalacije.

Tehnički podaci

Radni pritisak:	maks. 1 MPa
Preporučeni radni pritisak:	0,1 - 0,5 MPa
Probni pritisak:	1,6 MPa
	(1 MPa = 10 bar = 147 PSI)
Temperatura vruće vode:	maks. 70 °C
Preporučena temperatura vruće vode:	65 °C
Termička dezinfekcija:	maks. 70 °C / 4 min
Proizvod je koncipiran isključivo za pijaću vodu!	

Opis simbola



Nemojte koristiti silikon koji sadrži sirćetnu kiselinu!



Podešavanje (vidi stranu 34)

Podešavanje ograničivača tople vode. U kombinaciji sa protočnim bojlerima ne preporučuje se primena sistema za blokiranje dotoka tople vode.



Mere (vidi stranu 36)



Dijagram protoka (vidi stranu 37)

slobodan protok



Rezervni delovi (vidi stranu 38)

XXX = Oznake boja
 000 = Hrom
 090 = Dezen Hrom/Zlatna
 140 = Brushed Bronze
 340 = Brushed Black Chrome
 400 = Bela/Hrom
 670 = Matt Black
 700 = Matt White
 990 = Polished Gold-Optic



Poseban pribor (vidi stranu 41)

Nije sadržano u isporuci

- Produžetak 25 mm #13595000
- Produžetak 22 mm (kod manje dubine ugradnje)



Čišćenje (vidi stranu 42)



Rukovanje (vidi stranu 35)



Ispitni znak (vidi stranu 48)

Smetnja

Uzrok

Pomoć

Ručica se zaglavila

- Neispravna kartuša, nataloženi kamenac

- Zamenite kartušu

Slavina kaplje

- Neispravna kartuša

- Zamenite kartušu

Preniska temperatura tople vode, nema hladne vode. Protočni bojler se pali iako je puštena hladna voda.

- Ograničavač vruće vode nije dobro podešen

- Podesite ograničavač vruće vode

- Ukršteni tok vode

- Zamenite kartušu





Sikkerhetshenvisninger

- △ Bruk hansker under montasjen for å unngå klem- og kuttskader.
- △ Produktet skal kun brukes for bade-, hygiene- og kroppshygiene.
- △ Store trykkdifferanser mellom kaldt- og varmtvannstilkoblinger skal utlignes.

Montagehenvisninger

- Før montasjen skal produktet sjekkes for transportskader. Etter monteringen aksepteres ikke noen transport- eller overflateskader.
- Ledningene og armaturen skal monteres, spyles og sjekkes iht. de gyldige normer.
- Gjeldende retningslinjer for rørleggerarbeid i de enkelte land skal følges.

Tekniske data

Driftstrykk	maks. 1 MPa
Anbefalt driftstrykk:	0,1 - 0,5 MPa
Prøvetrykk	1,6 MPa
	(1 MPa = 10 bar = 147 PSI)
Varmtvannstemperatur	maks. 70 °C
Anbefalt temperatur for varmt vann	65 °C
Termisk desinfisering:	maks. 70 °C / 4 min
Produktet er utelukkende designet for drikkevann!	

Symbolbeskrivelse



Ikke bruk silikon som inneholder eddiksyre!



Justering (se side 34)

Innstilling av varmtvannsbegrensning. I forbindelse med gjennomstrømningsvarmere er det ikke anbefalt å bruke en varmtvannsperre.



Mål (se side 36)



Gjennomstrømningsdiagram
(se side 37)

fri gjennomstrømning



Serviceleder (se side 38)

XXX = Fargekode

000 = Krom

090 = Krom/Gull-Optikk

140 = Brushed Bronze

340 = Brushed Black Chrome

400 = Hvit/Krom

670 = Matt Black

700 = Matt White

990 = Polished Gold-Optic



Ekstratilbehør (se side 41)

ikke med i leveransen

- Forlengelse 25 mm #13595000

- Forlengelse 22 mm (ved liten montasjedybde)



Rengjøring (se side 42)



Betjening (se side 35)



Prøvemerket (se side 48)

Feil	Årsak	Feilrettelse
Armatur ikke lett bevegelig	- Kartusj defekt, forkalkning	- Kartusj byttes
Armatur drypper	- Kartusj defekt	- Kartusj byttes
For lav varmtvannstemperatur, ikke noe kaldtvann. gjennomstrømningsvarmerer slår seg på når det velges kaldt vann.	- Varmtvannsbegrensning er feil innstilt - Krysstrømning	- Varmtvannsbegrensning innstilles - Kartusj byttes



Указания за безопасност

- ⚠ При монтажа трябва да се носят ръкавици, за да се избегнат наранявания поради притискане или порязване.
- ⚠ Позволено е използването на продукта само за къпане, хигиена и цели на почистване на тялото.
- ⚠ Големите разлики в налягането между изводите за студената и топлата вода трябва да се изравняват.

Указания за монтаж

- Преди монтажа продуктът трябва да се провери за транспортни щети. След монтажа не се признават транспортни или повърхностни щети.
- Тръбопроводите и арматурата трябва да се монтират, промият и проверят в съответствие с валидните норми.
- Трябва да бъдат спазвани валидните в съответните страни предписания за инсталиране.

Технически данни

Работно налягане:	макс. 1 МПа
Препоръчително работно налягане:	0,1 - 0,5 МПа
Контролно налягане:	1,6 МПа (1 МПа = 10 bar = 147 PSI)
Температура на горещата вода:	макс. 70 °C
Препоръчителна температура на горещата вода:	65 °C
Термична дезинфекция:	макс. 70 °C / 4 мин
Продуктът е разработен само за питейна вода!	

Описание на символите



Не използвайте силикон, съдържащ оцетна киселина!



Юстиране (вижте стр. 34)

Настройка на ограничителя за топлата вода. Във връзка с проточни нагреватели не се препоръчва блокировка за топлата вода



Размери (вижте стр. 36)



Диаграма на потока (вижте стр. 37)

свободен поток



Сервизни части (вижте стр. 38)

XXX = Цветово кодиране
 000 = Хром
 090 = Хром/Оптика За Злато
 140 = Brushed Bronze
 340 = Brushed Black Chrome
 400 = Бял/Хром
 670 = Matt Black
 700 = Matt White
 990 = Polished Gold-Optic



Специални принадлежности (вижте стр. 41)

не се съдържа в обема на доставка

- Удължител 25 мм #13595000
- Удължител 22 мм (при малка монтажна дълбочина)



Почистване (вижте стр. 42)



Обслужване (вижте стр. 35)



Контролен знак (вижте стр. 48)

Неизправност	Причина	Помощ
Трудно подвижна арматура	- Дефектна гилза, покрита с варовик	- Сменете гилзата
Арматурата капе	- Дефектна гилза	- Сменете гилзата
Твърде ниска температура на топлата вода, няма студена вода.	- Ограничението за топлата вода е грушно настроено	- Настройте ограничението за топлата вода
Проточният нагревател се задейства, когато се избере студена вода	- Кръстосване на потока	- Сменете гилзата



Udhëzime sigurie

- △ Për të evituar lëndimet e pickimeve ose të prerjeve gjatë procesit të montimit duhet që të vishni doreza.
- △ Produkti duhet të përdoret vetëm qëllimet e banjave, të higjienës dhe të larjes së trupit.
- △ Ndryshimet e mëdha të presionit mes lidhjeve të ujit të ftohtë dhe atij të ngrohtë duhen ekuilibruar.

Udhëzime për montimin

- Përpara montimit duhet që produkti të kontrollohet për dëmtime nga transporti. Pas instalimit nuk do të njihet asnjë dëmtim nga transporti ose dëmtim i sipërfaqes.
- Tubacionet dhe rubinetet duhet që të montohen, të shpëlahen dhe të kontrollohen sipas standardeve në fuqi
- Duhet të respektohen linjat udhëzuese të instalimit, të vlefshme për vendet respektive.

Të dhëna teknike

Presioni gjatë punës	maks. 1 MPa
Presioni i rekomanduar:	0,1 - 0,5 MPa
Presioni për provë:	1,6 MPa (1 MPa = 10 bar = 147 PSI)
Temperatura e ujit të ngrohtë	maks. 70 °C
Temperatura e rekomanduar e ujit të ngrohtë:	65 °C
Dezinfektim Termik:	maks. 70 °C / 4 min

Produkti është projektuar ekskluzivisht për ujë të pijshëm!

Përshkrimi i simbolit



Mos përdorni silikon që në përbërje ka acid acetik.



Justimi (shih faqen 34)

Rregullimi i kufizimit me ujë të nxehtë. Nje kombinim me një bojler ujit nuk është i rekomanduar.



Përmasat (shih faqen 36)



Diagrami i qarkullimit
(shih faqen 37)

rrjedhja e lirë



Pjesët e servisit (shih faqen 38)

- XXX = Kodimi me anë të ngjyrave
- 000 = Krom
- 090 = Krom/I Arte-Optike
- 140 = Brushed Bronze
- 340 = Brushed Black Chrome
- 400 = E Bardhë/Krom
- 670 = Matt Black
- 700 = Matt White
- 990 = Polished Gold-Optic



Pajisje të posaçme (shih faqen 41)

nuk përfshihet në vëllimin e furnizimit

- Zgjatësi 25 mm #13595000
- Zgjatësi 22 mm (lartësia e montimit jo e madhe)



Pastrimi (shih faqen 42)



Përdorimi (shih faqen 35)



Shenja e kontrollit (shih faqen 48)

Dëmtim

Shkaku

Ndihme

Armatura punon rende	- Kartusha me defekt, me kalk	- Kembeni kartushen
Armatura pikon	- Kartusha me defekt	- Kembeni kartushen
Temperaturë e ulët e ujit të ngrohtë, nuk ka ujë të ftohtë. Ngrohësi elektrik i ujit ndizet kur zgjidhet uji i ftohtë.	- Kufiri i ujit te ngrohte eshte regjistruar gabim - Rrjedhje e kryqëzuar.	- Regjistroni kufirin e ujit te ngrohte - Kembeni kartushen



وصف الرمز

هام! لا تستخدم السليكون الذي يحتوي على أحماض!

الضبط (راجع صفحة 34)

ضبط تحديد المياه الدافئة. لا ينصح باستخدام محدد المياه الدافئة مع سخان المياه الوتقي.

أبعاد (راجع صفحة 36)

رسم للصراف (راجع صفحة 37)
التدفق الحر

قطع الغيار (راجع صفحة 38)

XXX = الألوان
000 = كروم
090 = كروم/لون ذهبي
Brushed Bronze = 140
Brushed Black Chrome = 340
400 = أبيض/كروم
Matt Black = 670
Matt White = 700
Polished Gold-Optic = 990

ملحقات خاصة (راجع صفحة 41)

غير مدرج مع المحتويات المسلمة
• وصلة إطالة 25 مم #13595000

• طقم الملحقات 22 مم (عندما لا يكون الجدار عميقاً بما يكفي)

التنظيف (راجع صفحة 42)

التشغيل (راجع صفحة 35)

شهادة اختبار (راجع صفحة 48)

تنبيهات الأمان

⚠ يجب إرتداء قفازات لليد أثناء التركيب لتجنب حدوث أخطار الإنحشار أو الجروح.

⚠ لا يجب استخدام المنتج إلا في أغراض الاستحمام والأغراض الصحية وأغراض تنظيف الجسم.

⚠ يجب أن يكون تيار الماء الساخن والماء البارد متعادلين في الضغط.

تعليمات التركيب

- قبل القيام بعملية التركيب، يجب فحص المنتج للتأكد من خلوه من أية تلفيات ناتجة عن النقل. بعد القيام بعملية التركيب، لن يتم الاعتراف بوجود أية تلفيات سطحية أو تلفيات ناتجة عن عملية النقل.
- يجب تركيب وغسيل واختبار التوصيلات وخلطات المياه طبقاً للمعايير السارية.
- يجب مراعاة القواعد الخاصة بالتركيب وأعمال السباكة وفقاً للوائح الخاصة بكل بلد.

المواصفات الفنية

ضغط التشغيل: الحد الأقصى 1 ميجاباسكال

ضغط التشغيل الموصى به: 0,1 - 0,5 ميجاباسكال

ضغط الاختبار: 1,6 ميجاباسكال

(1 ميجاباسكال = 10 بار = 147 PSI)

درجة حرارة الماء الساخن: الحد الأقصى 70°C

درجة الحرارة الموصى بها للماء الساخن: 65°C

تعقيم حراري: الحد الأقصى 4 / 70°C الدقيقة

المنتج مخصص فقط لماء الشرب!

العطل	السبب	العلاج والإصلاح
الخلط ثقيل الحركة	- الخرطوشة تالفة، تراكم عليها الجير	- قم بتغيير الخرطوشة
تساقط قطرات مياه من الخلط	- الخرطوشة تالفة	- قم بتغيير الخرطوشة
درجة حرارة الماء الساخن منخفضة للغاية، ولا يوجد ماء بارد. سخان المياه الفوري يعمل عند استخدام الماء البارد.	- محدد الماء الساخن مضبوط بشكل خاطيء - اندفاع متعكس للمياه	- قم بضبط محدد الماء الساخن - قم بتغيير الخرطوشة



Biztonsági utasítások

- △ A szerelésnél a zúzódások és vágási sérülések elkerülése érdekében kesztyűt kell viselni.
- △ A terméket csak fürdéshez, mosakodáshoz, és egészségügyi tisztálkodáshoz szabad használni.
- △ A hidegvíz- és a melegvíz-csatlakozások közötti nagy nyomáskülönbséget kicell egyenlíteni!

Szerelési utasítások

- A szerelés előtt ellenőrizni kell, hogy a terméknek nincs-e szállítási sérülése. Beépítés után a szállítási- vagy felületi sérüléseket nem ismerik el.
- A vezetékeket és a csaptelepet az érvényes szabványoknak megfelelően kell felszerelni, öblíteni és ellenőrizni
- Az egyes országokban érvényes installációs irányelveket be kell tartani.

Műszaki adatok

Üzemi nyomás:	max. 1 MPa
Ajánlott üzemi nyomás:	0,1 - 0,5 MPa
Nyomáspróba:	1,6 MPa
	(1 MPa = 10 bar = 147 PSI)

Forróvíz hőmérséklet:	max. 70 °C
Forróvíz javasolt hőmérséklete:	65 °C
Termikus fertőtlenítés:	max. 70 °C / 4 perc

A terméket kizárólag ivóvízhez tervezték!

Szimbólumok leírása



Ne használjon ecetsavtartalmú szilikon!



Beállítás (lásd a oldalon 34)

A meleg víz korlátozás beállítása. Átfolyós vízmelegítőknél meleg víz korlátozó használata nem ajánlott.



Méretet (lásd a oldalon 36)



Átfolyási diagramm

(lásd a oldalon 37)

szabad átfolyás



Tartozékok (lásd a oldalon 38)

XXX = Színkódolás

000 = Króm

090 = Króm/Arany-Hatású

140 = Brushed Bronze

340 = Brushed Black Chrome

400 = Fehér/Króm

670 = Matt Black

700 = Matt White

990 = Polished Gold-Optic



Egyéb tartozék (lásd a oldalon 41)

a szállítási egység nem tartalmazza

- Hosszabbítás 25 mm #13595000
- Hosszabító készlet 22 mm (kis beépítési mélység esetén)



Tisztítás (lásd a oldalon 42)



Használat (lásd a oldalon 35)

- A csaptelepeken átfolyt víz hőmérséklete fogyasztásra szánt víz esetében a 65 °C-ot nem haladhatja meg. A csaptelep nem eredményezheti az emberi fogyasztásra (pl. ivás és főzés céljából) szánt víz minőségromlását.
- Beüzemelés és üzemszünetek után szigorúan be kell tartani a használati útmutatóban leírtakat. Beüzemeléskor a csaptelepet át kell öblíteni, legalább 2 percig történő hideg- és melegvízes folytatást javasolunk. Minimum 1 napos üzemszünet után fogyasztás előtt a csaptelepben stagnáló hideg- illetve melegvíz fogyasztása nem javasolt, a csaptelepben stagnáló vizet ki kell engedni, legalább 2 perces folytatás javasolt. A kifolytatás során nyert vizet ivóvízként, illetve ételkészítési céllal felhasználni nem szabad.
- Tekintettel arra, hogy a forró víz fémoldó képessége a hideg víznél nagyobb, emiatt főzés ivás céljából az OKI a hideg víz használatát javasolja.
- A csaptelepek perlátorát javasolt havonta vízkőtelepíteni, illetve fertőtleníteni. A csaptelepek tisztítása, fertőtlenítése során kizárólag olyan gyegyszer alkalmazható, amely megfelel a 201/2001. (X.25) Kormányrendelet, illetve a 38/2003. (VII.7) ÉSzcM-FVM-KvVM együttes rendeletben leírtaknak.
- A perlátor működési elvéből adódóan jelentős aeroszolt képez, így Legionella expozíció szempontjából fokozott kockázatot jelent. Ezért alkalmazása nem javasolt az egészségügyi intézmények fekvőbeteg ellátó szobáiban, illetve minden olyan helyen, ahol a hideg és / vagy használati melegvíz Legionella csíraszama eléri a 49/2015 (XI.6.) EMMI rendelet alapján meghatározott beavatkozási szintet.



Vizsgajel (lásd a oldalon 48)



Hiba	Ok	Megoldás
Nehezen nyitható a csap.	- A kerámiabetét meghibásodott, elvízkövesedett.	- A kerámiabetétet ki kell cserélni.
Csöpög a csap.	- A kerámiabetét meghibásodott.	- A kerámiabetétet ki kell cserélni.
Túl alacsony melegvíz hőmérséklet, nincs hidegvíz. A hidegvíz kiválasztásakor beindul az átfolyós melegítő.	- A melegvíz szabályozó rosszul van beállítva. - Kereszfolyás	- A melegvíz szabályozót újra be kell állítani. - A kerámiabetétet ki kell cserélni.

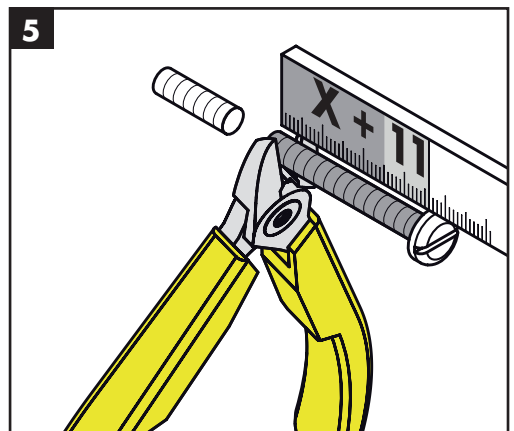
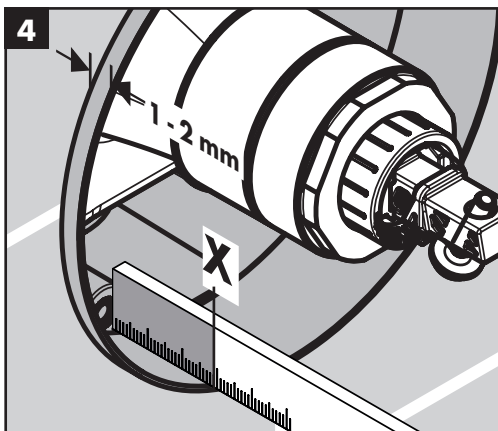
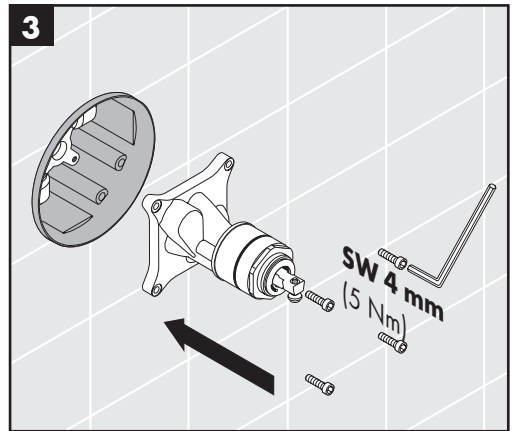
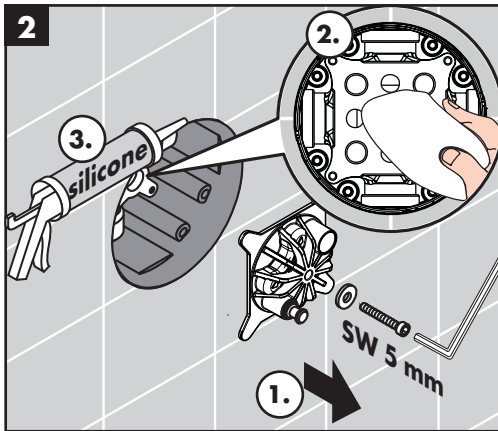
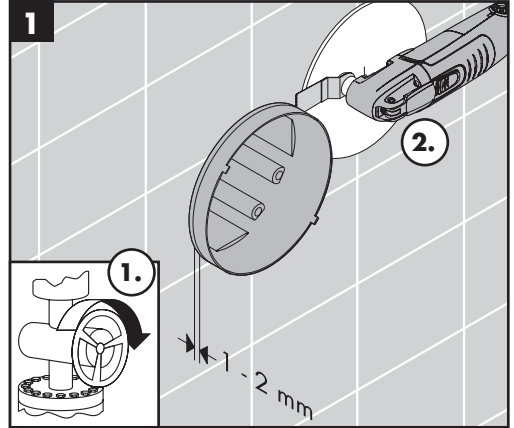
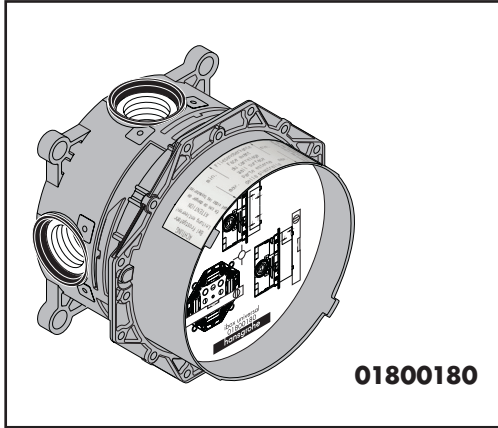

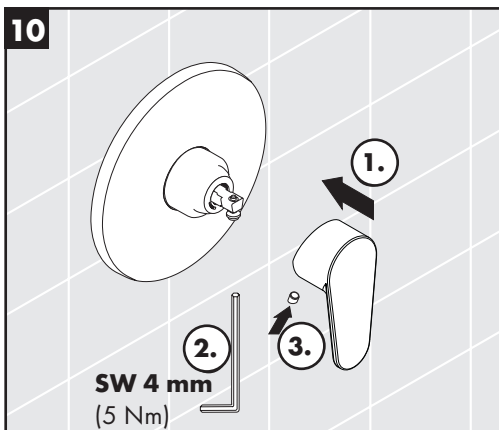
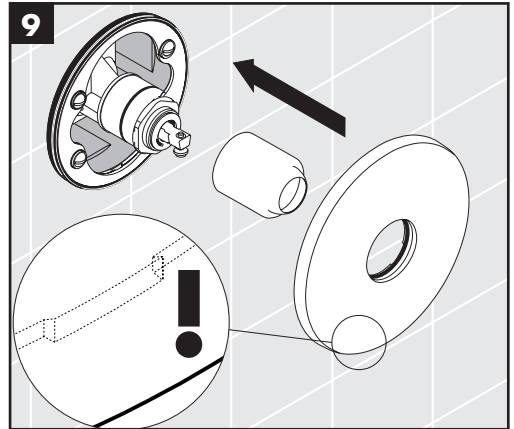
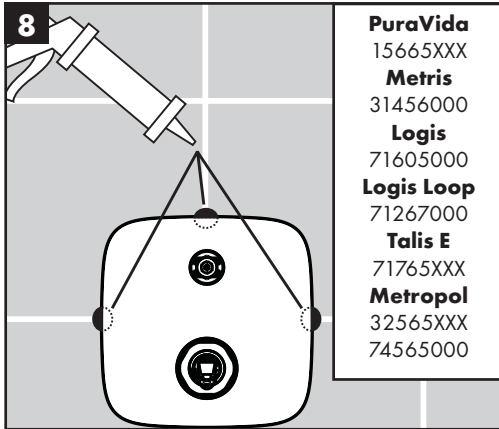
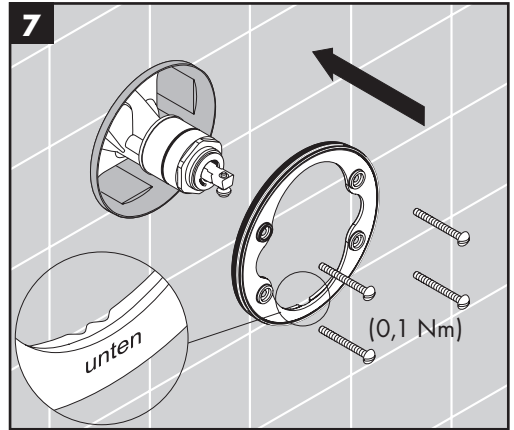
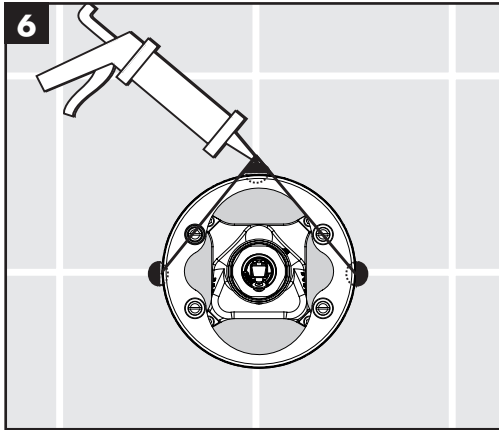

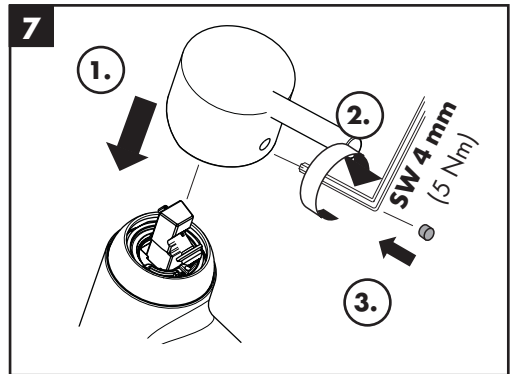
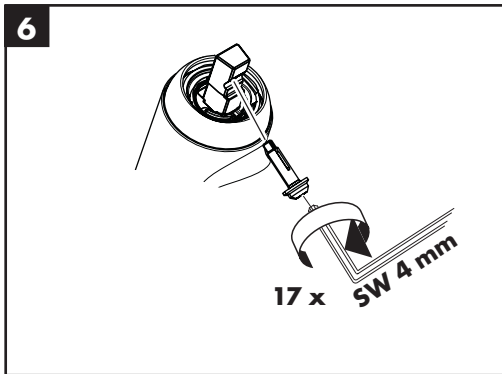
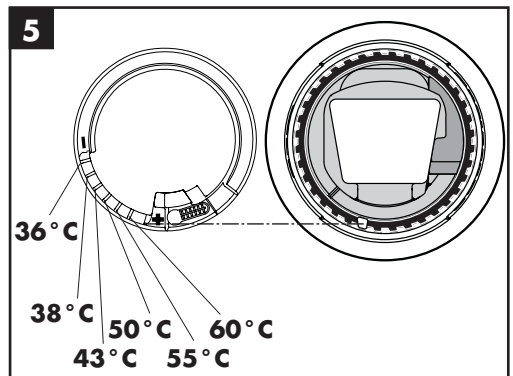
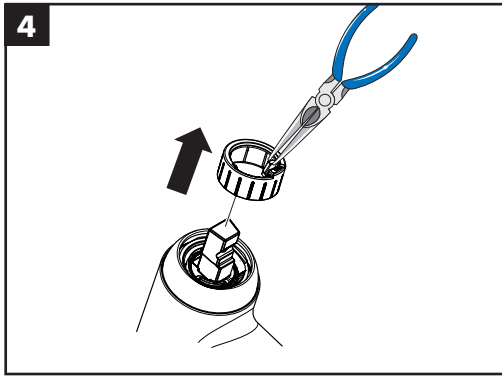
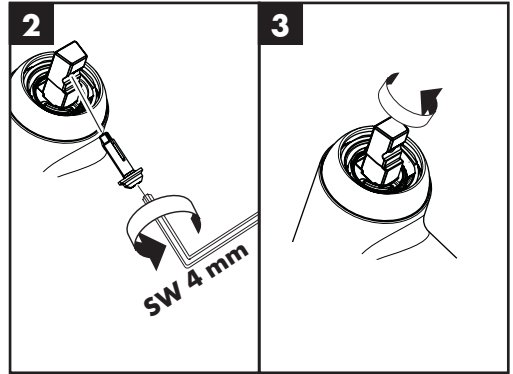
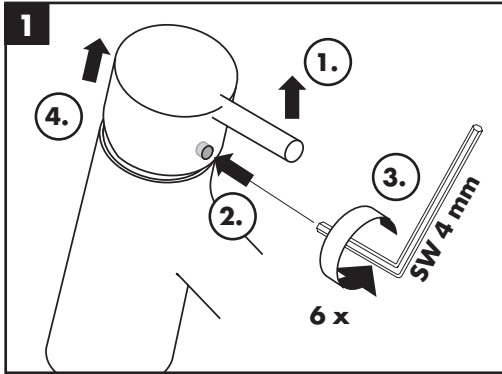

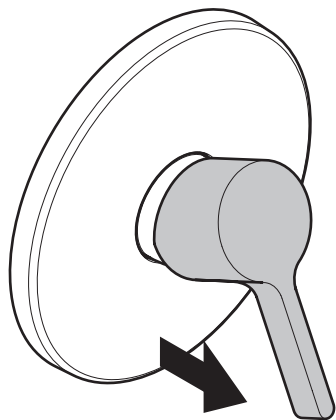

öffnen / ouvert / open / aperto / abierto / open /
 åbne / abrir / otworzyć / otevřít / otvorit / 开 /
 открыть / nyitás / avaaminen / öppna / atidaryti /
 Otvaranje / açmak / deschide / ανοικτό / odpreti /
 avage / atvērt / otvoriti / åpne / отваряне / hare / فتح

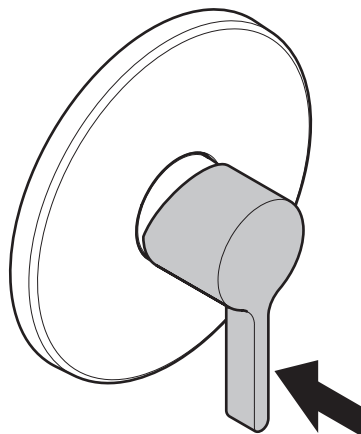

schließen / fermé / close / chiudere / cerrar / sluiten /
 lukke / fechar / zamknąć / zavřít / uzavrieť / 关 /
 закрыть / bezárás / sulkeminen / stänga / uždaryti /
 Zatvaranje / kapatmak / închide / κλειστό / zapreti /
 sulgege / aizvērt / zatvori / lukke / затваряне /
 mbylle / إغلاق

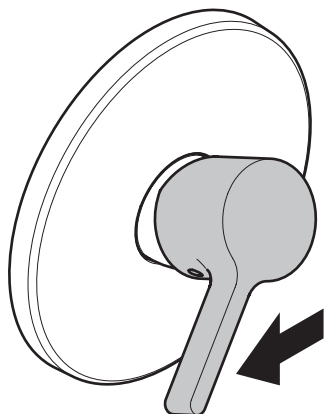

warm / chaud / hot / caldo / caliente / varm / varmt /
 quente / ciepła / teplá / teplá / 热 / горячая / meleg /
 lämmin / varmi / karštas / Vruća voda / sıcak / cald /
 ζεστό / toplo / kuum / karsts / topla / varm / тепло /
 i ngrohtë / ساخن

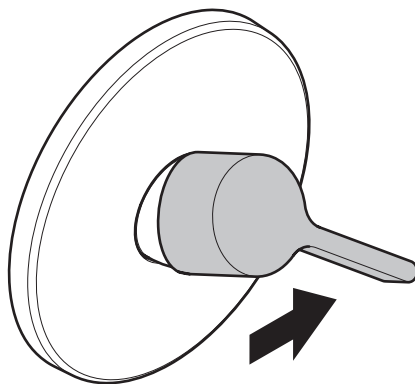

kalt / froid / cold / freddo / frío / koud / koldt / fria /
 zimna / studená / studená / 冷 / холодная / hideg /
 kylmä / kallt / šaltas / Hladno / soğuk / rece / κρύο /
 mrzlo / külm / auksts / hladno / kaldt / студено /
 i ftohtë / بارد

**Talis Classic**

14165000

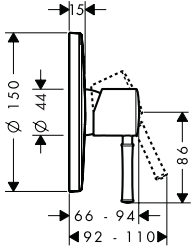
**PuraVida**

15665XXX

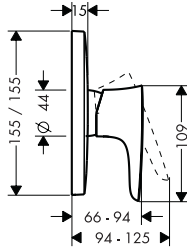
**Metropol Classic**

31365XXXX

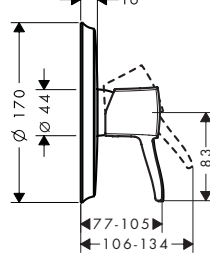
**Metris**

31456000

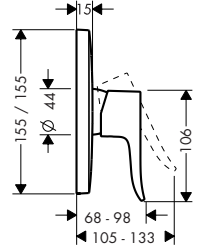
**Metris S**

31665000

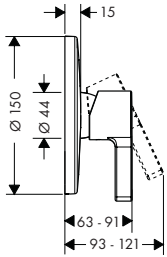
**Talis S / Talis**

32675XXX

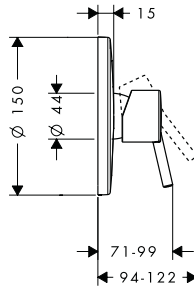
**Metris Classic**

31676XXX

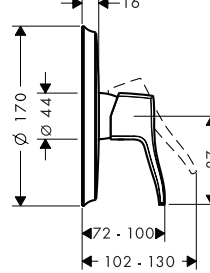
**Metris**

31685000

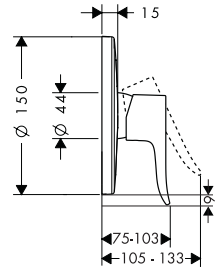
**Focus**

31965000

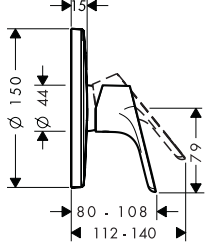
**Talis S**

72605000

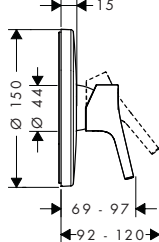
**Logis Loop**

71267000

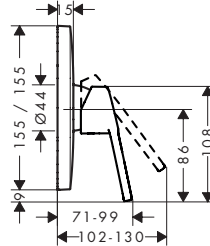
**Logis E**

71603000

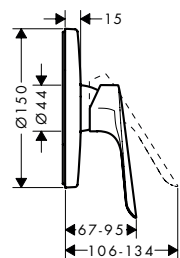



Talis E
71765XXX

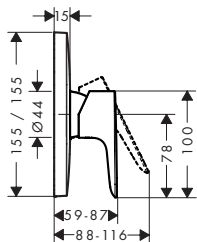

Logis
71605000

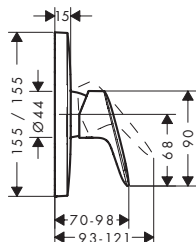

Metropol
32565XXX / 74565000

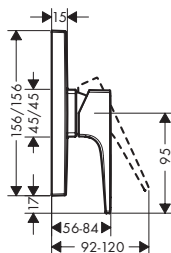

Novus
71065000 / 71065003

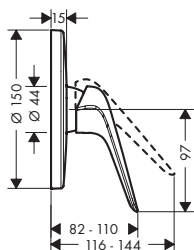

Novus Loop
71365000

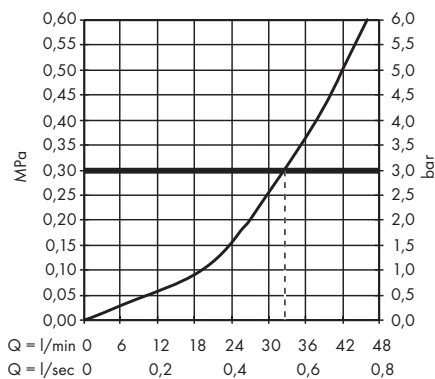
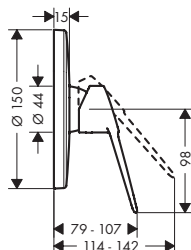



Talis Classic 14165000

Metris S 31665000

Focus 31965000

Talis S / Talis 32675XXX

Talis S 72605000

Metris 31685000

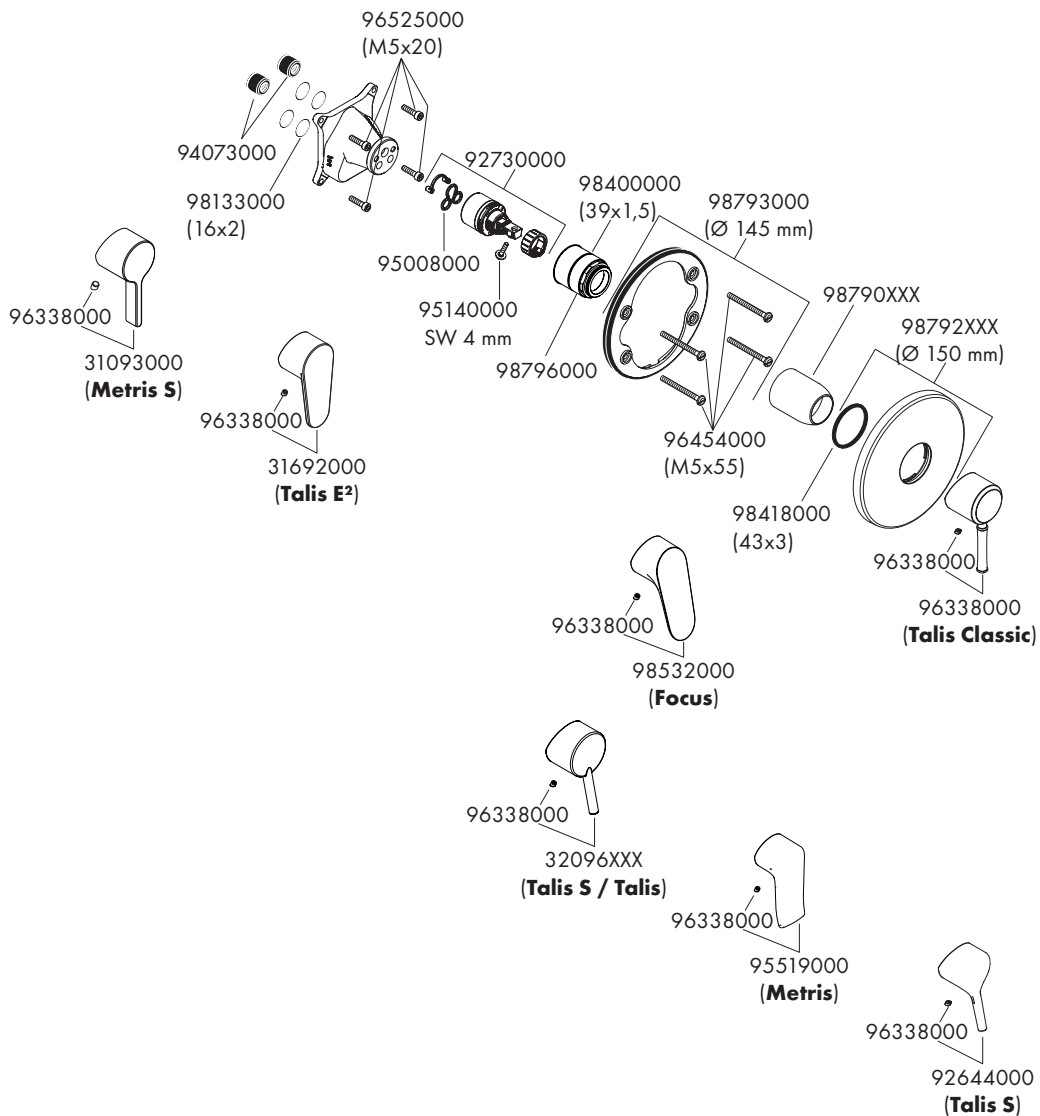



PuraVida 15665XXX

Metris 31456000

Logis 71605000

Talis E 71765XXX

Logis Loop 71267000

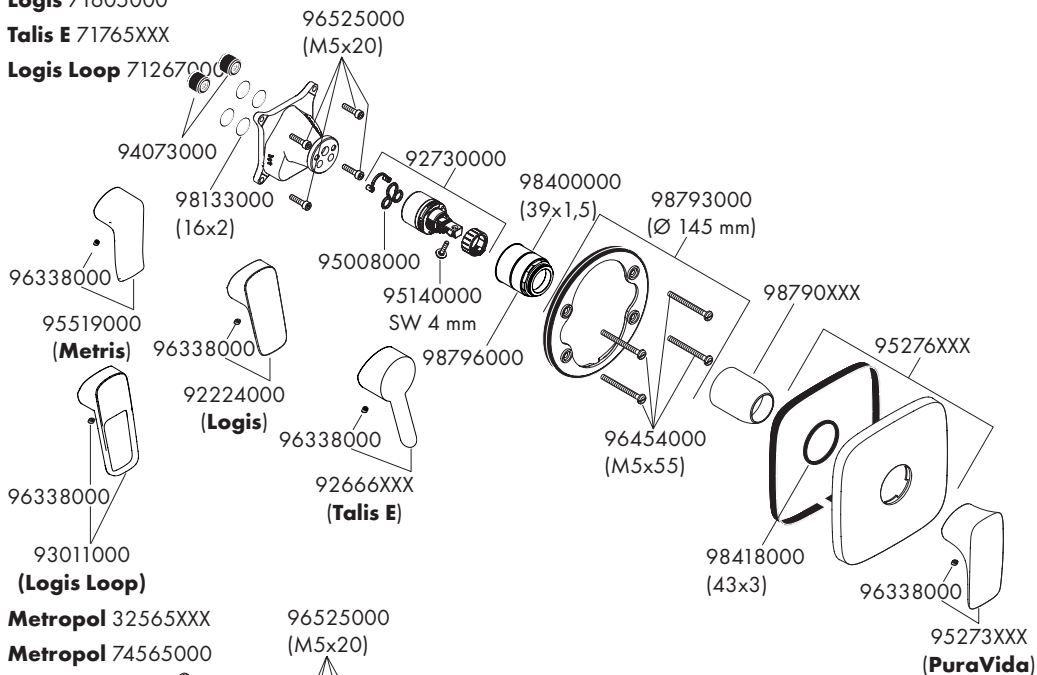

Metropol 32565XXX

Metropol 74565000

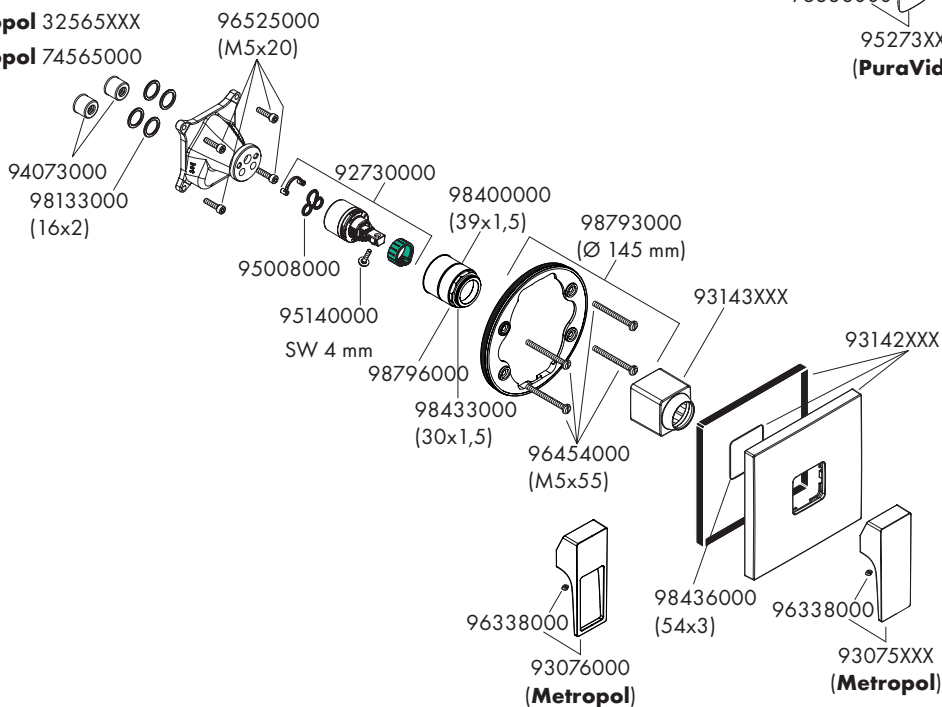



Metropol Classic 31365XXX

Metris Classic 31676XXX

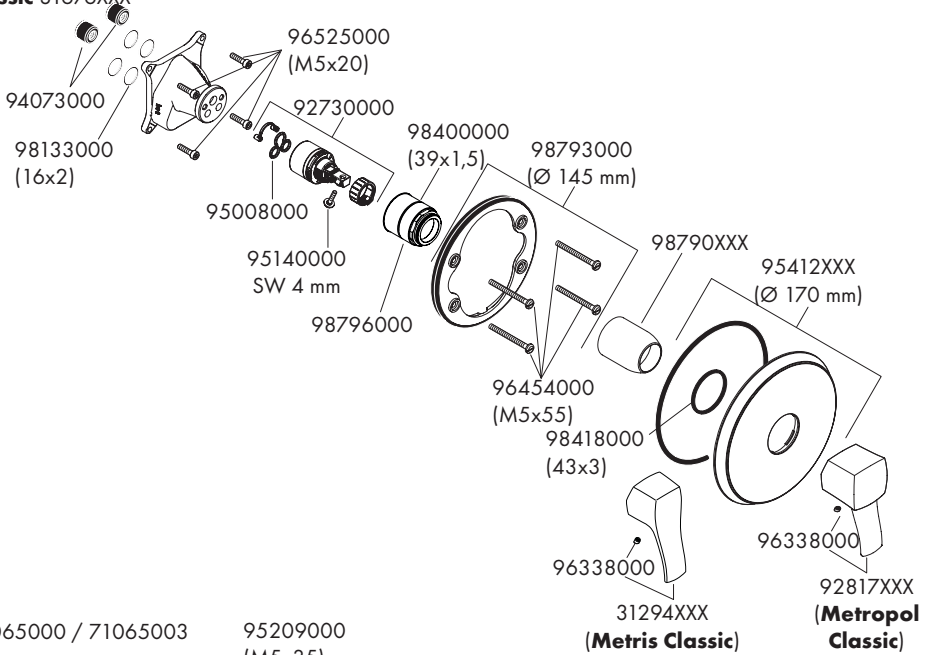

Novus 71065000 / 71065003

Novus Loop 71365000

Logis E 71603000

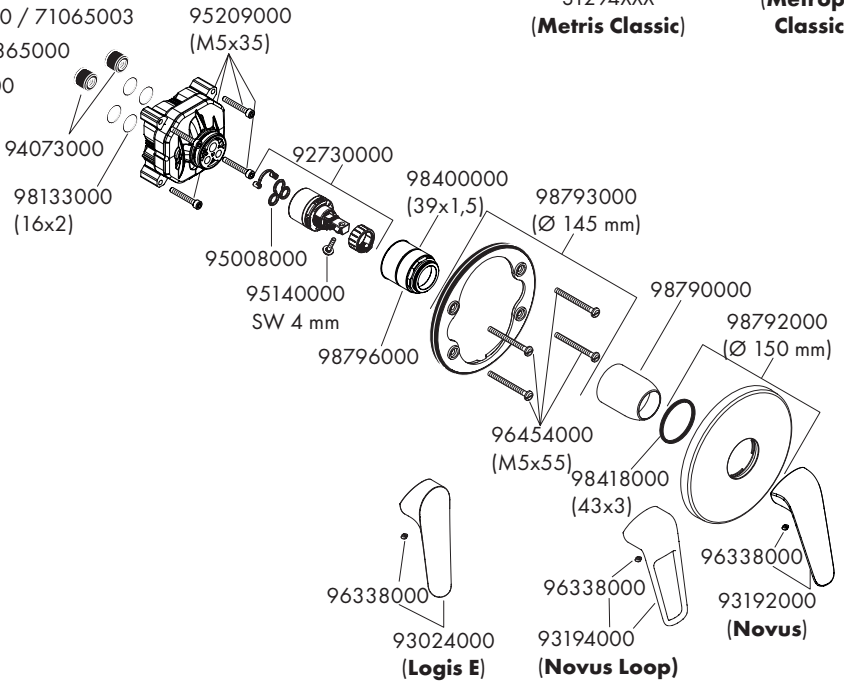



Talis Classic 14165000
Metris S 31665000
Focus 31965000
Talis S / Talis 32675XXX
Talis S 72605000
Metris 31685000

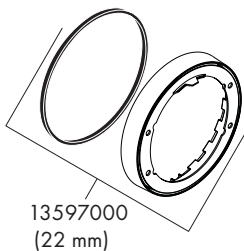

Metropol Classic 31365XXX
Metris Classic 31676XXX

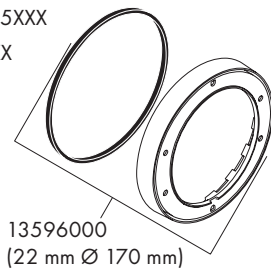

PuraVida 15665XXX
Metris 31456000
Logis 71605000
Talis E 71765XXX
Logis Loop 71267000

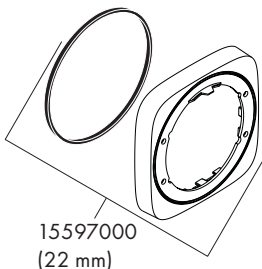

Novus 71065000 / 71065003
Novus Loop 71365000
Logis E 71603000

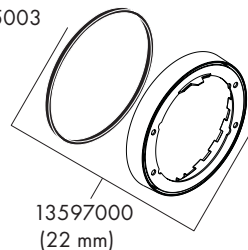

Metropol 32565XXX
Metropol 74565000

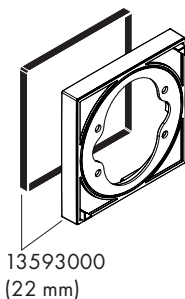

Talis Classic 14165000
Metris S 31665000
Focus 31965000
Talis S / Talis 32675XXX
Talis S 72605000
Metris 31685000
PuraVida 15665XXX
Metris 31456000
Logis 71605000
Talis E 71765XXX
Logis Loop 71267000
Metropol 32565XXX
Metropol 74565000
Metropol Classic 31365XXX
Metris Classic 31676XXX
Novus 71065000 / 71065003
Novus Loop 71365000
Logis E 71603000

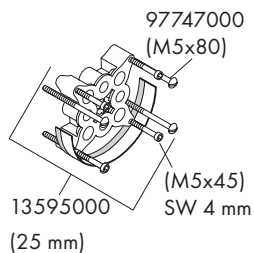



- DE** Reinigungsempfehlung / Garantie / Kontakt
- FR** Recommandation pour le nettoyage / Garanties / Contact
- EN** Cleaning recommendation / Warranty / Contact
- IT** Raccomandazione di pulizia / Garanzia / Contatto
- ES** Recomendaciones para la limpieza / Garantía / Contacto
- NL** Aanbevelingen inzake reiniging / Garantie / Contact
- DK** Rensning, anbefaling / Garanti / Kontakt
- PT** Recomendações de limpeza / Garantia / Contacto
- PL** Zalecenie dotyczące pielęgnacji / Gwarancja / Kontakt
- CS** Doporučení k čištění / Záruka / Kontakt
- SK** Odporúčania pre čistenie / Záruka / Kontakt
- ZH** 清洁指南 / 担保 / 接触
- RU** Рекомендации по очистке / Гарантия / Контакты
- HU** Tisztítási tanácsok / Garancia / érintkezés
- FI** Puhdistussuositus / Takuu / Kosketus
- SV** Rengöringsrekommendationer / Garanti / Contacto
- LT** Valymo rekomendacijos / Garantija / Kontaktai
- HR** Preporuke za čišćenje / Garancija / Kontakt
- TR** Temizleme önerisi / Garanti / Temas
- RO** Recomandări pentru curățare / Garanție / Contact
- EL** Σύσταση καθαρισμού / Εγγύηση / επαφή
- SL** Priporočilo za čišćenje / Garancija / Kontakt
- ET** Puhastussoovitused / Garantii / Kontakt
- LV** Tīrīšanas ieteikumi / Garantija / Kontakti
- SR** Preporuke za čišćenje / Garancija / Kontakt
- NO** Anbefaling for rengjøring / Garanti / Kontakt
- BG** Препоръка за почистване / Гаранция / Контакт
- SQ** Këshilla rreth pastrimit / Garancia / Kontakt
- KO** 세정시 권장사항 / 품질보증 / 접촉
- AR** توصيات التنظيف / الضمان (الولايات المتحدة الأمريكية) / اتصال



[www.hansgrohe.com/
cleaning-recommendation](http://www.hansgrohe.com/cleaning-recommendation)



[www.hansgrohe.com/
cleaning-recommendation](http://www.hansgrohe.com/cleaning-recommendation)



[www.hansgrohe.com/
cleaning-recommendation](http://www.hansgrohe.com/cleaning-recommendation)



[www.hansgrohe.com/
cleaning-recommendation](http://www.hansgrohe.com/cleaning-recommendation)











P-IX

DVGW

SINTEF

NF



ETA



GODKENDT
TIL DRIKKEVAND

14165000		CQ0125	X			X
15665XXX	PA-IX 9710/IB	CQ0125	X			X
31365XXX						X
31456000	PA-IX 9710/IB	CQ0125	X			X
31665000	PA-IX 9710/IB	CQ0125	X			X
31676XXX	PA-IX 9710/IB	CQ0125	X			X
31685000	PA-IX 9710/IB	CQ0125	X			X
31965000	PA-IX 9710/IB	CQ0125	X	X		X
32565XXX						X
32675XXX	PA-IX 9710/IB	CQ0125	X			X
71065000						X
71267000						X
71365000						X
71603000						X
71605000	PA-IX 9710/IB		X	X		X
71765XXX	PA-IX 9710/IB					X
72605000	PA-IX 9710/IB					X
74565000						X

