

3020285

02/10/13-04-13/05/19

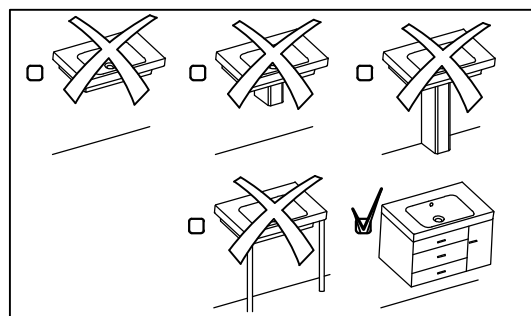

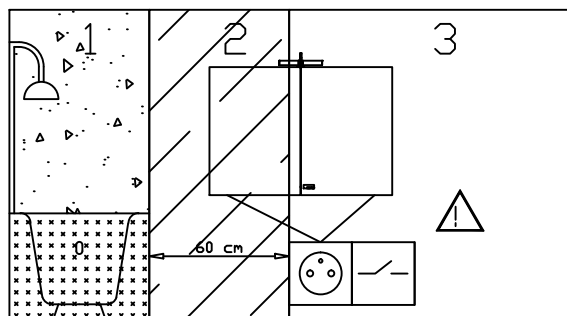
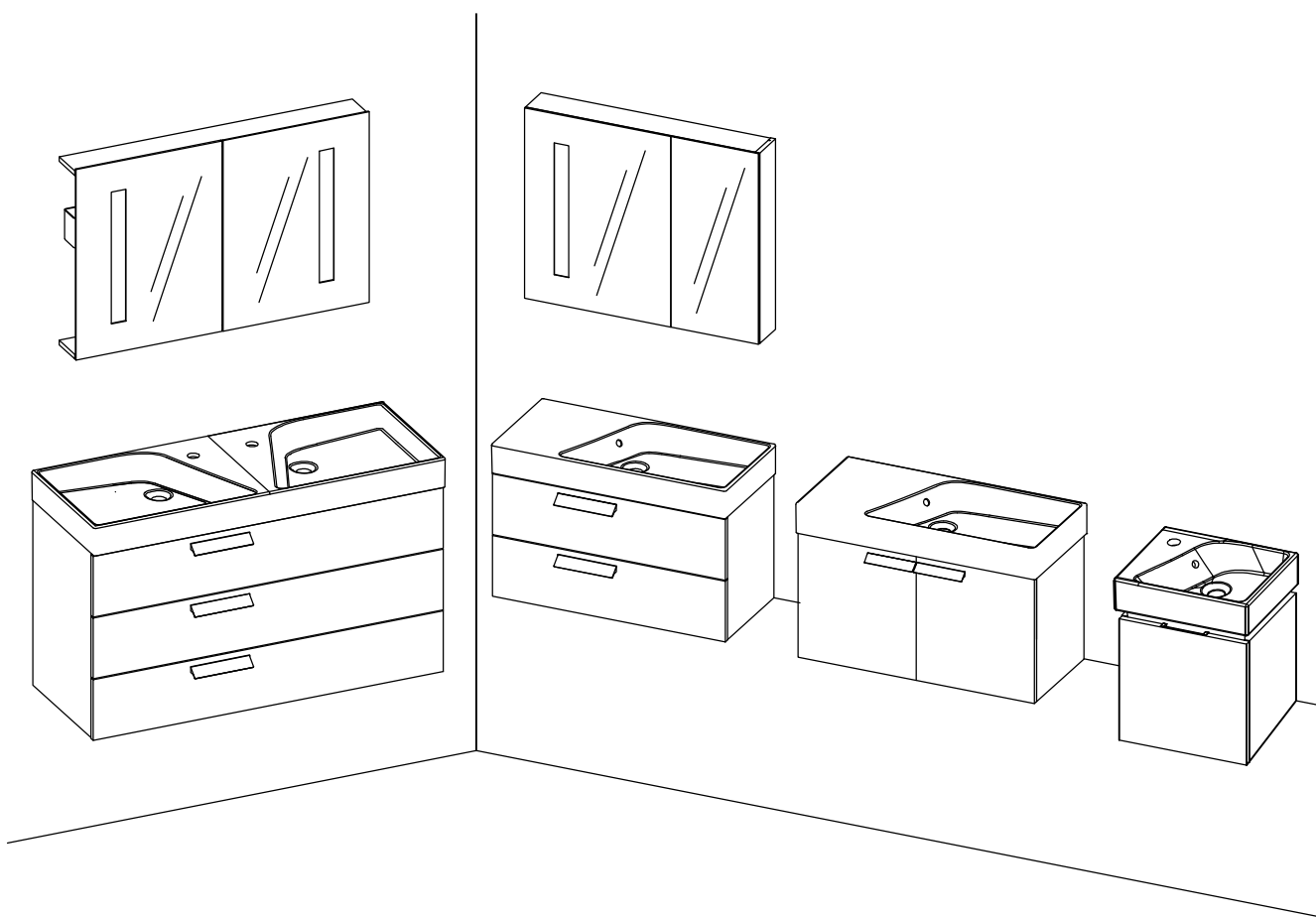

- (F) Cette notice est destinée à faciliter le montage du meuble, elle n'est pas contractuelle.
- (GB) Fitting instructions are intended to ease fitting. They are not subject to contract.
- (D) Unverbindliche Montageanleitung.
- (NL) Deze montagehandleiding is bedoeld om de montage te vereenvoudigen. Zij is niet bindend.
- (SP) Esta nota de instrucciones le ayudará a montar el mueble, no es contractual.
- (I) Le seguenti istruzioni sono destinate a facilitarvi il montaggio del mobile, e sono indicative.
- (P) Esta noticia é destinada a facilitar a montagem do móvel, não é contratual.
- (RUS) Інструкція з монтажу є допоміжною і не є договірною. Вона не є гарантією на монтаж меблів.



- (F) Le choix des types de vis et chevilles, ainsi que la méthode de perçage pour les fixations murales sont fonction de la nature et de la qualité du mur et, de ce fait, relèvent de la seule responsabilité du poseur.
- (GB) Since the type of wall determines the fittings necessary for each unit, bolts and screws have not been supplied but left to the responsibility of the installer.
- (D) Das Befestigungsmaterial (Schrauben und Dübel), muss je nach Beschaffenheit der Wand (Mauerwerk, Gipskarton etc.) ausgewählt werden. Die Verantwortung für die einwandfreie Installation, übernimmt der Fachmann.
- (NL) Omdat de manier van bevestigen bepaald wordt door het type muur, zijn schroeven en pluggen niet inbegrepen en vallen onder de verantwoordelijkheid van de installateur.
- (SP) La elección del tipo de los torillos y clavijos y el modo de perforar la pared dependen de la naturaleza y de la calidad del muro y por esto dependen de la responsabilidad de la persona quien instala.
- (I) La scelta dei tipi di viti e tasselli, oltre che il sistema di foratura per il fissaggio murale sono da scegliere in funzione della struttura e qualità del muro, e per questo. La responsabilità spetta a chi esegue la posa.
- (P) A escolha do tipos de parafusos e cavilhas assim que o metodo de furar para colocar as fixacoes murais depende da natureza e da qualidade do muro, e de facto, atribuem a unica responsabilidade ao instalador.
- (RUS) Вибір типів шурупів та цвяхів та методу свердління для кріплення до стіни залежить від її структури та якості. Відповідальність за правильну установку, несе фахівець.



- (F) Tous les raccordements électriques doivent être réalisés selon les réglementations en vigueur par une personne qualifiée
- (GB) All electrical connections must be made in accordance with the latest IEE regulations (BS EN) by a qualified person.
- (D) Alle elektrischen Anschlüsse, müssen gemäß den VDE-Vorschriften, von einem Fachmann installiert werden.
- (NL) Alle elektrische aansluiten dienen, conform de geldende normen, te worden geïnstalleerd door een erkend installateur
- (SP) Todas las conexiones eléctricas deberán ser realizadas por personal cualificado y siguiendo las regulaciones marcadas por el IEE (Instituto de Ingenieros Eléctricos)
- (I) Elettriche devono essere eseguite da personale qualificato e in conformità alle più recenti norme IEE (Institution of Electrical Engineers)
- (P) Todos os racordamentos eléctricos devem ser realizados segundo as reglementações em vigor por uma pessoa qualificada
- (RUS) Все электрические соединения должны устанавливаться квалифицированным персоналом и соответствовать последним стандартам IEE (Институт Инженерной Электроники, Великобритания)

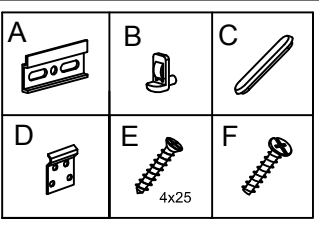
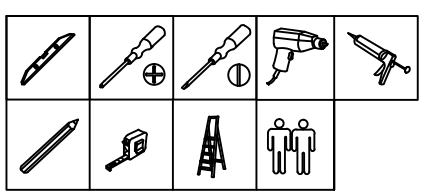
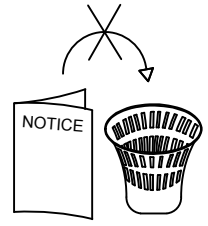
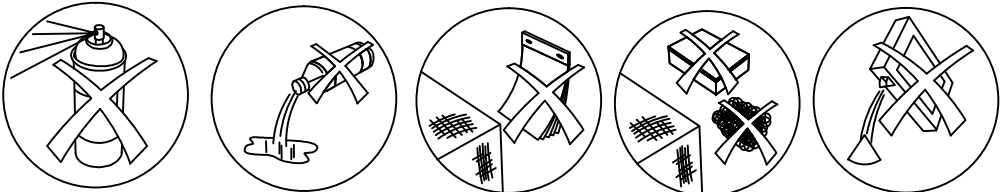

1

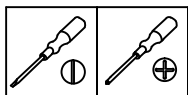
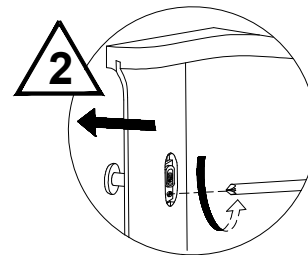
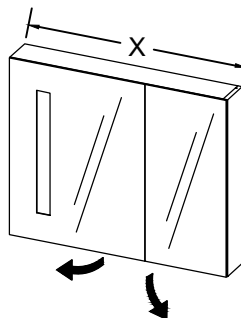
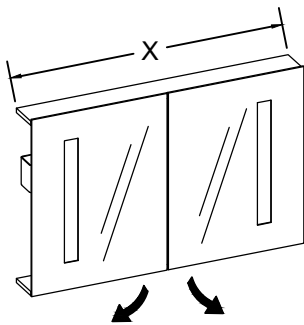
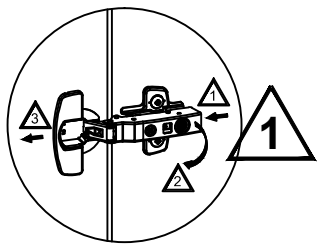

2

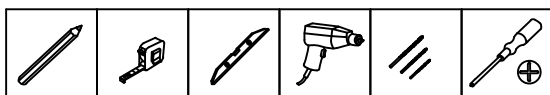
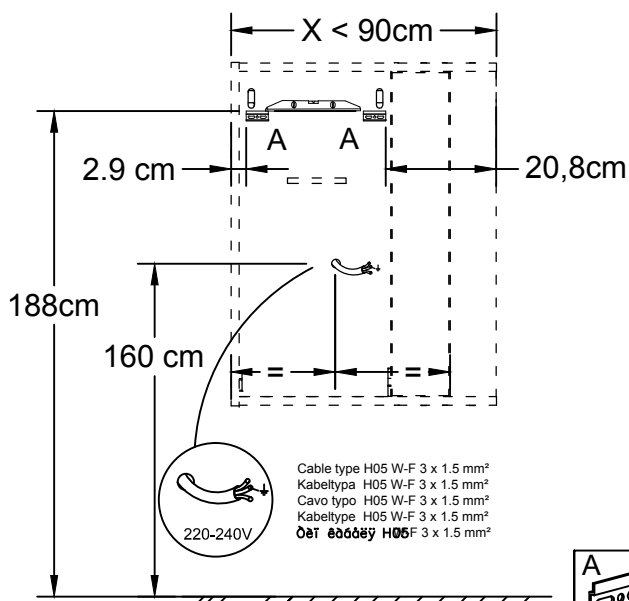
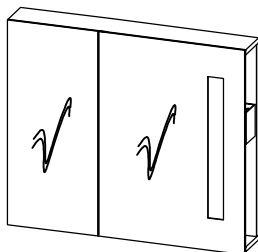
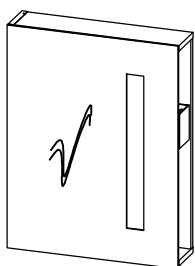

3

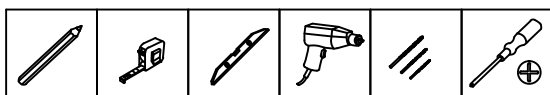
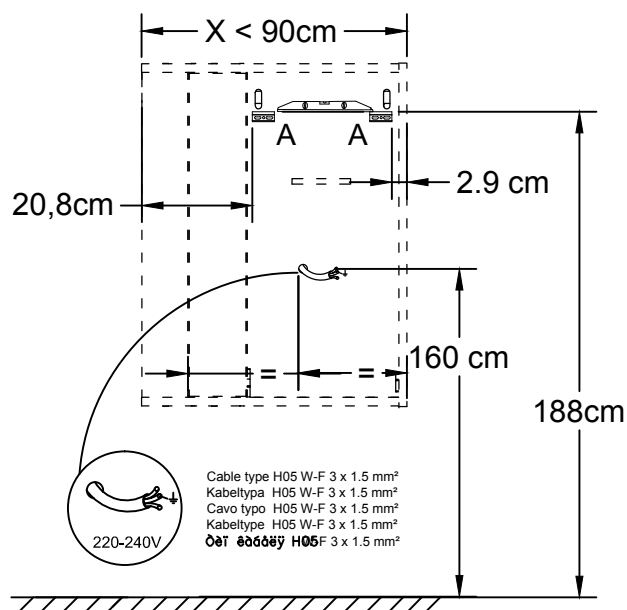
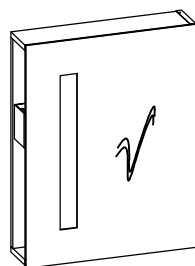
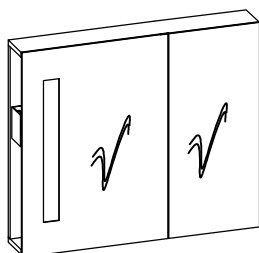

4

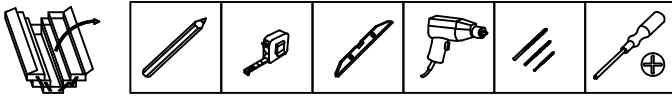
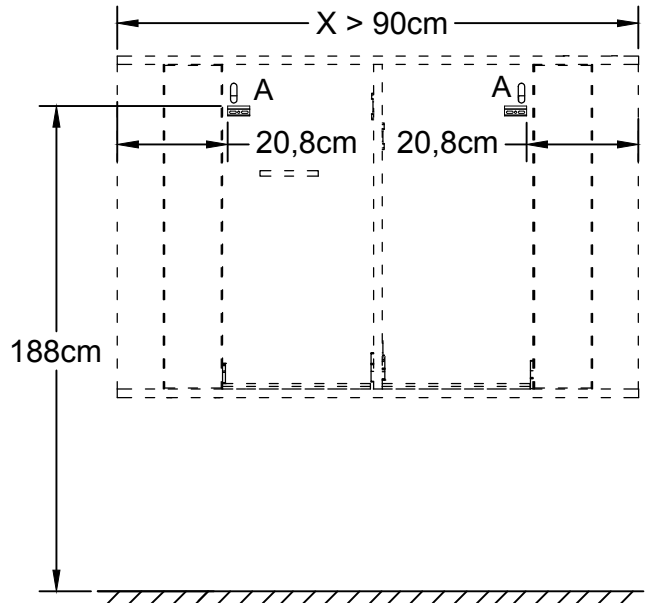
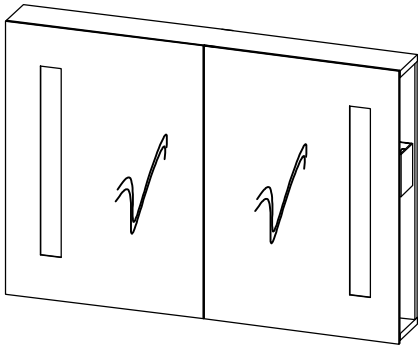

5

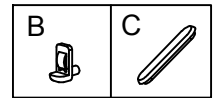
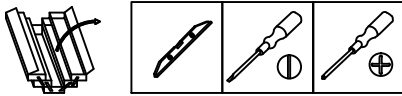
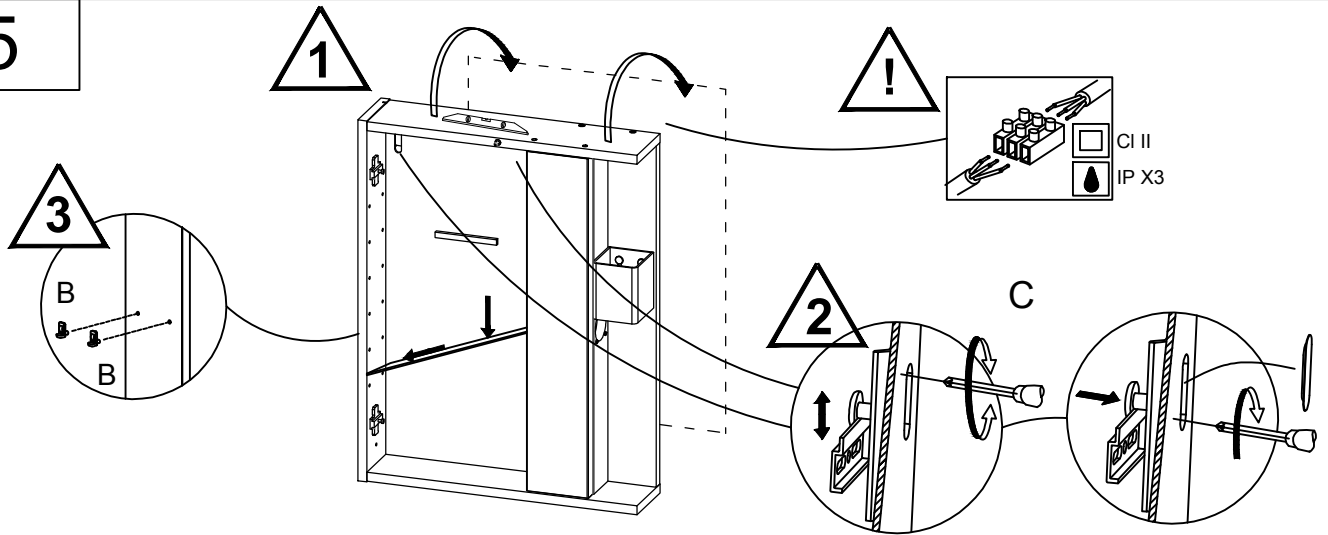

6

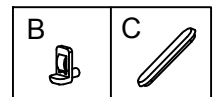
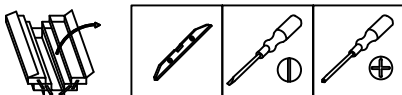
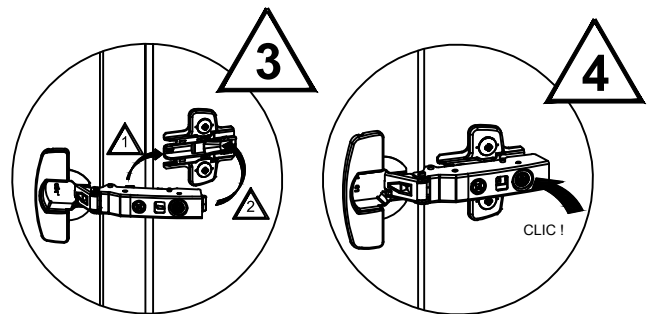
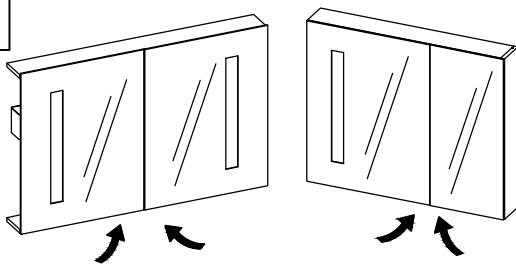

7

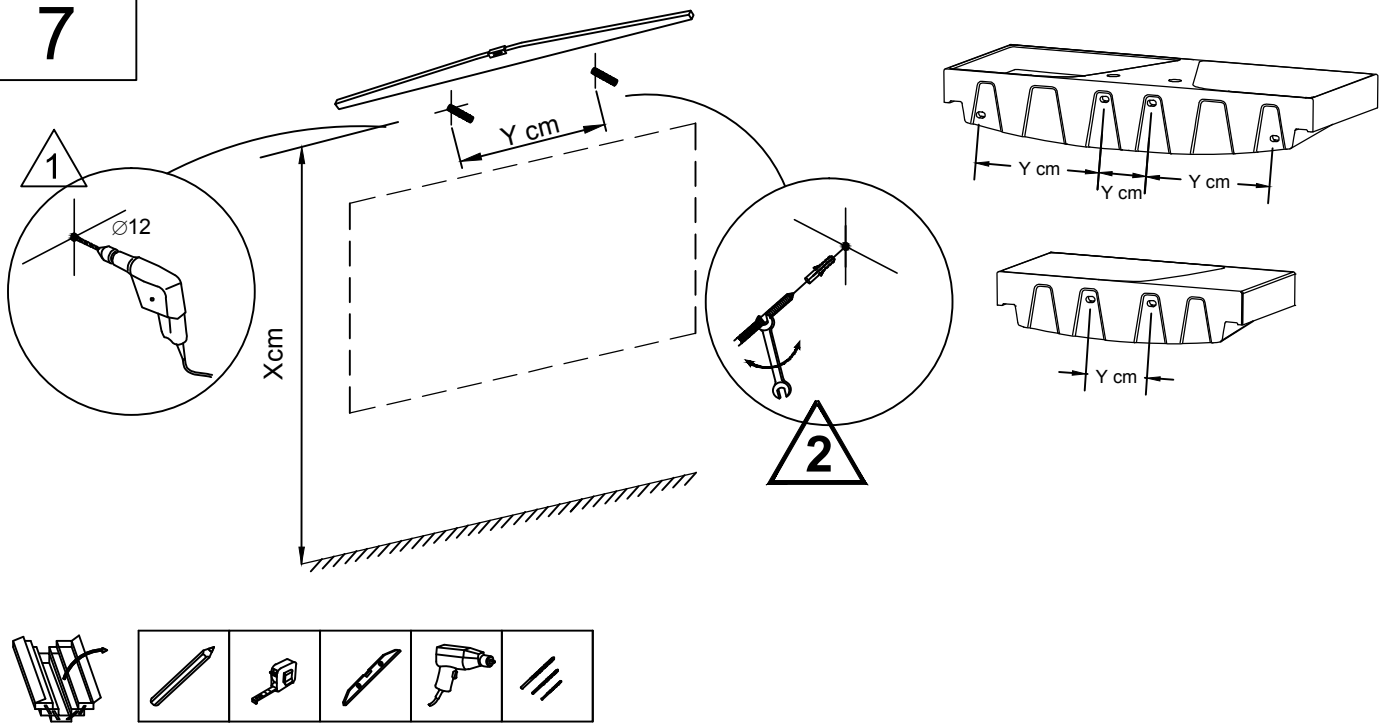

8

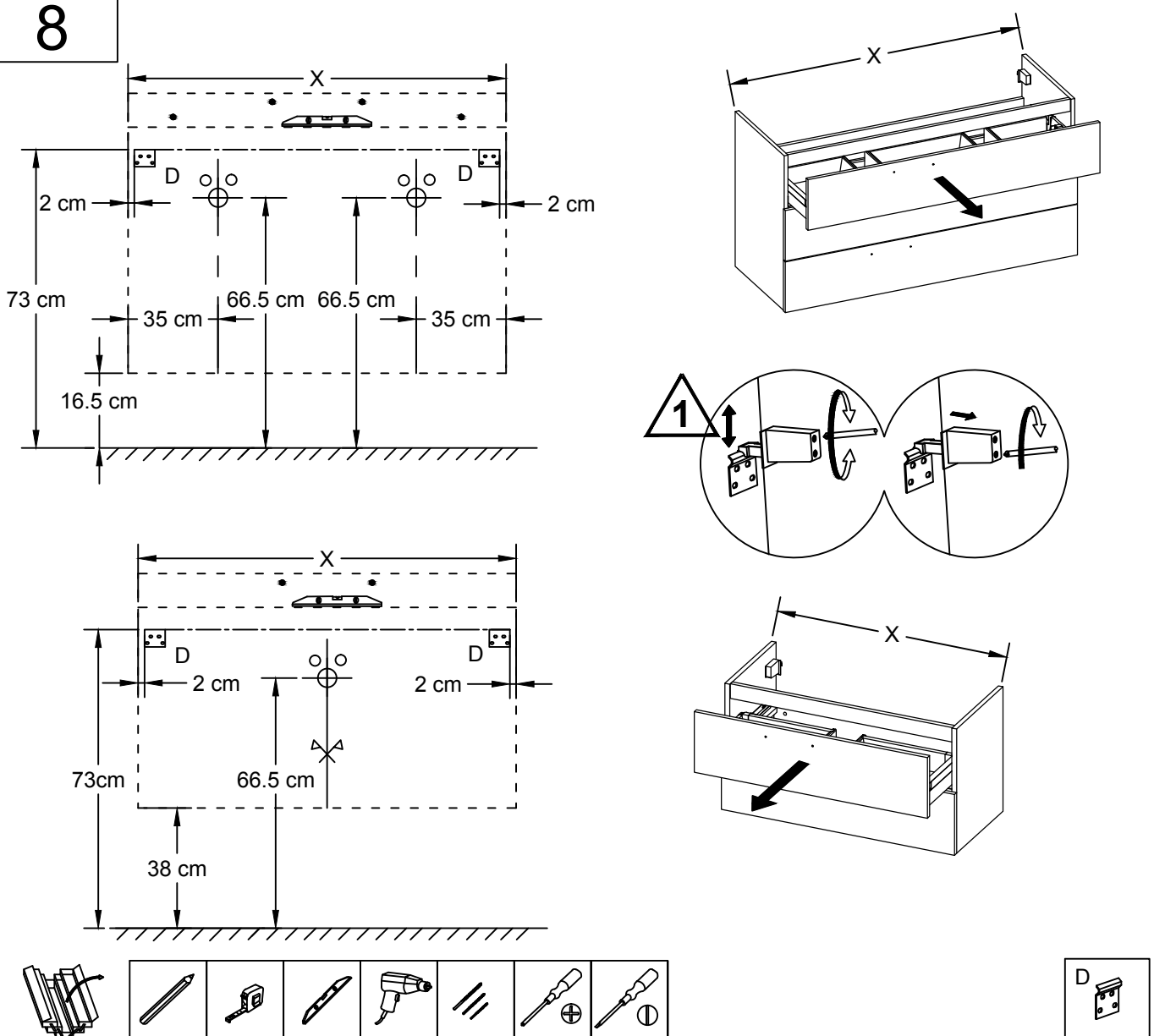

9

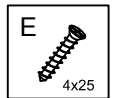
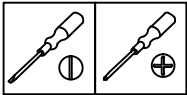
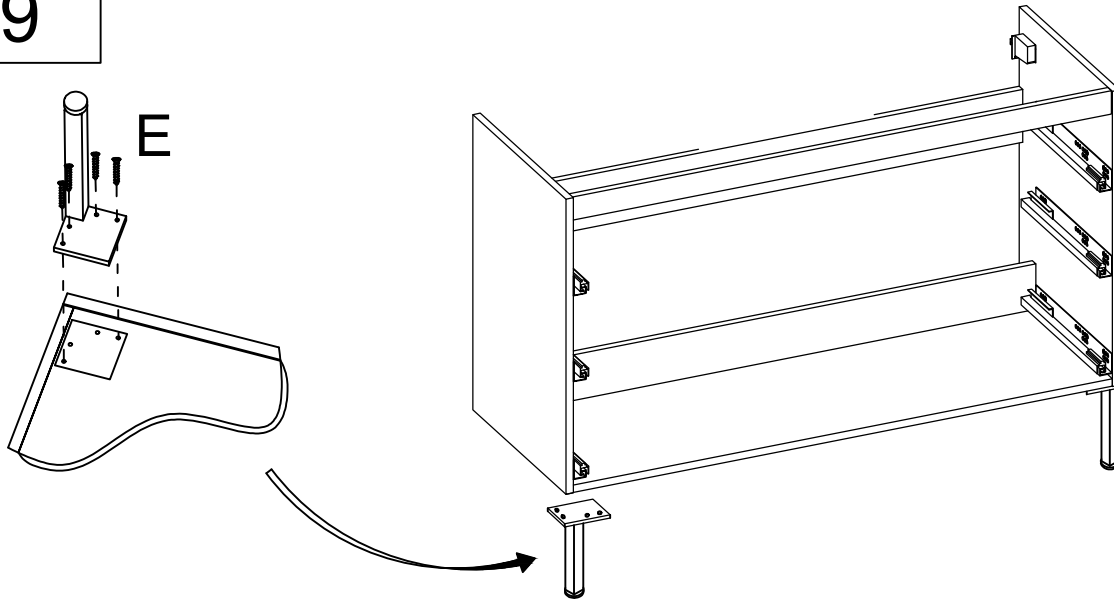

10

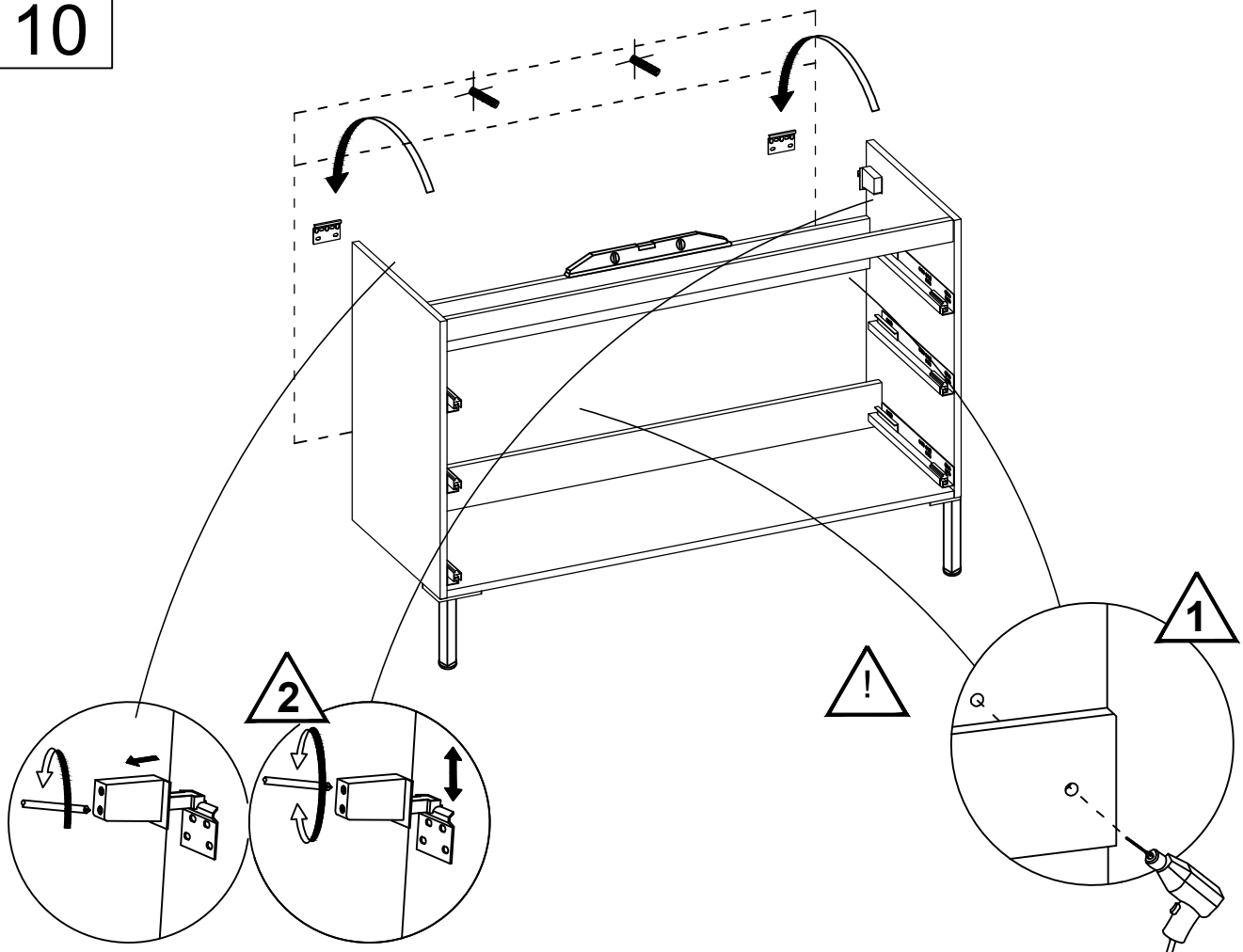

11

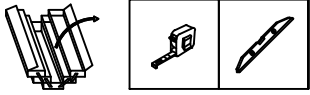
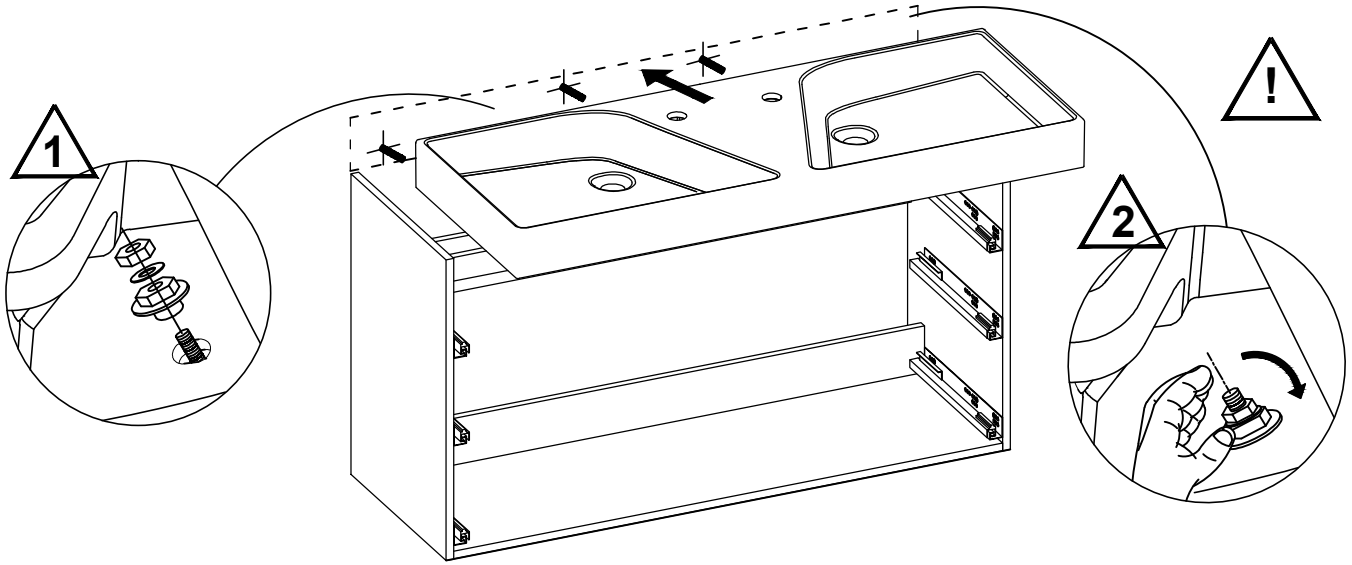

12

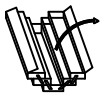
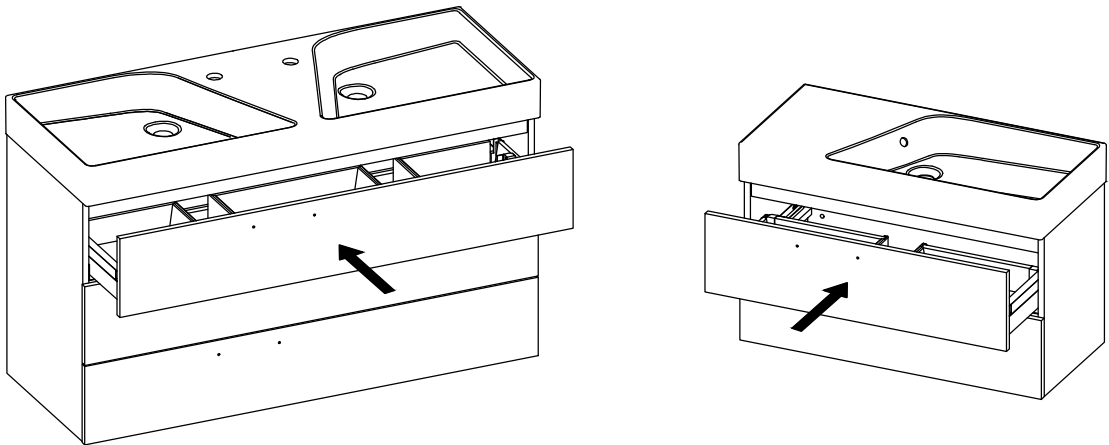

13

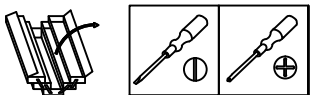
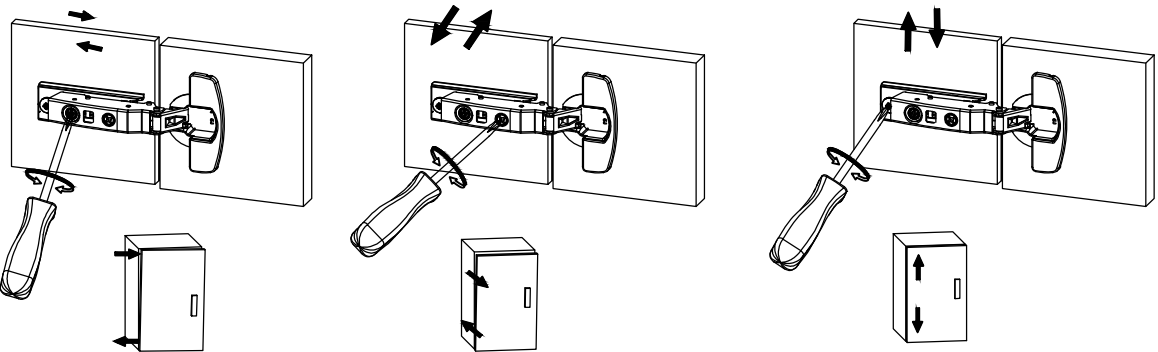

14

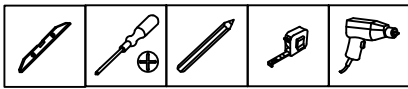
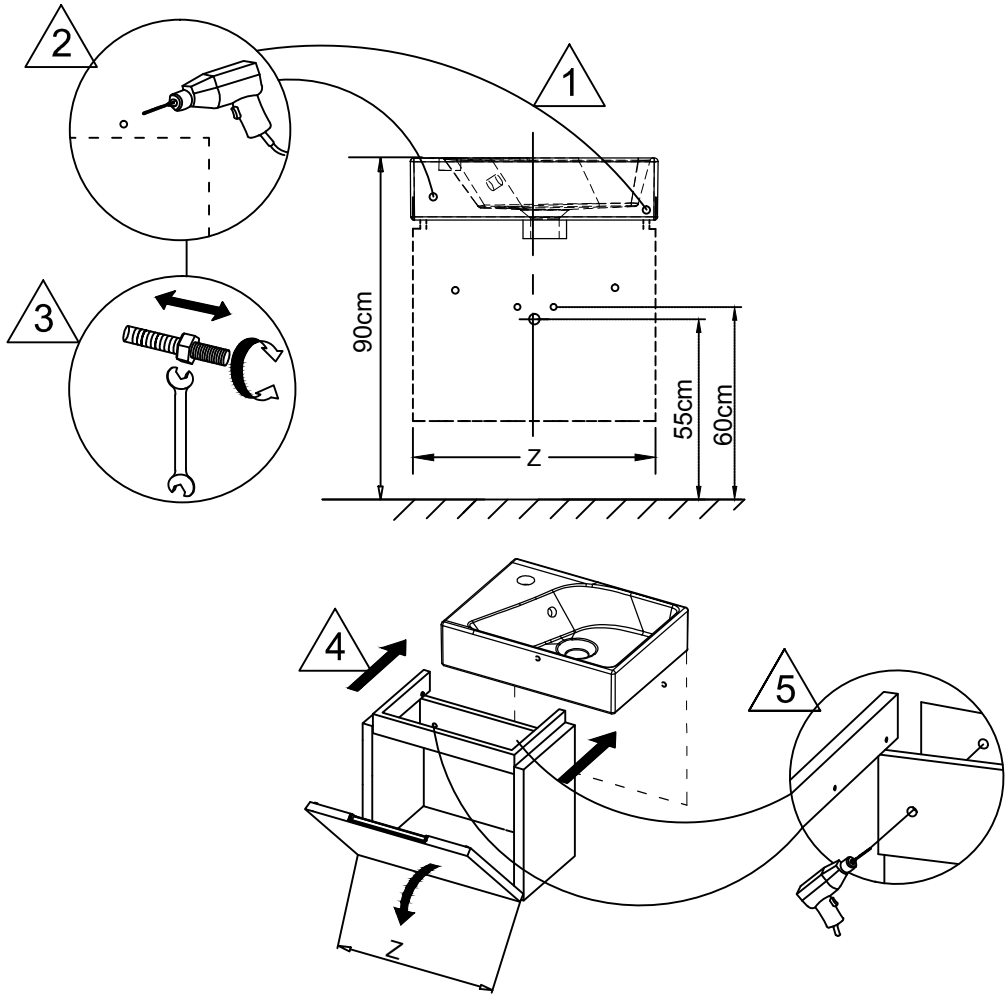

15

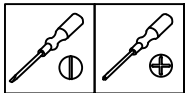
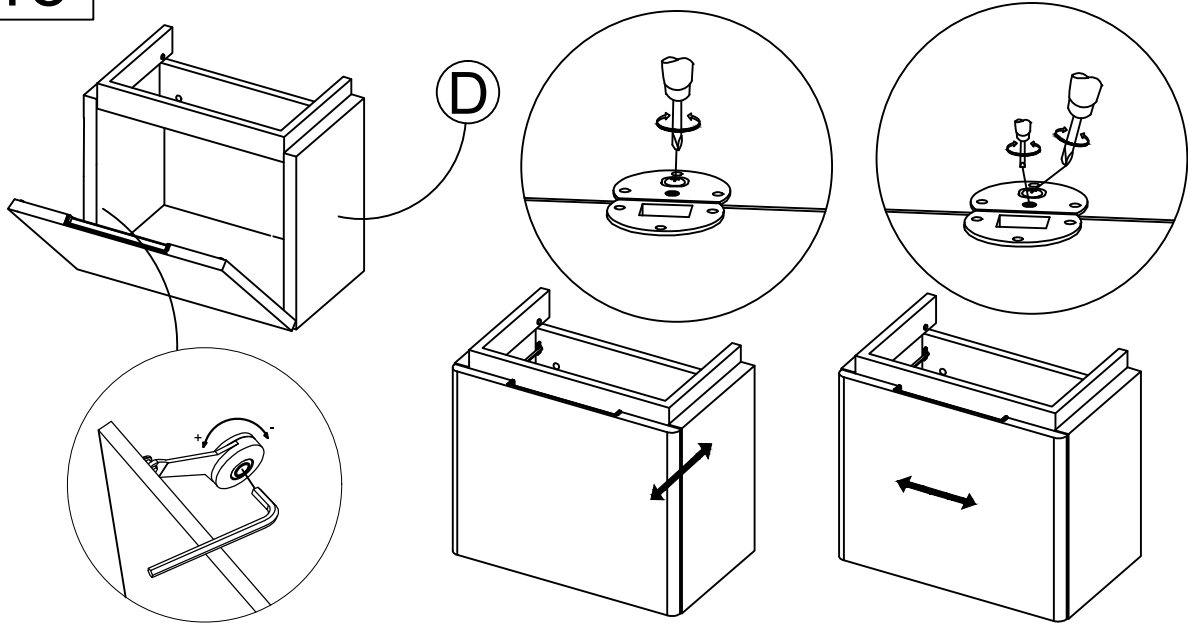

16

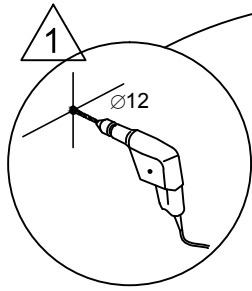
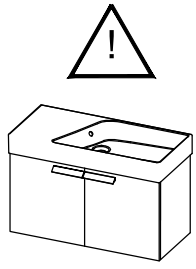

X cm

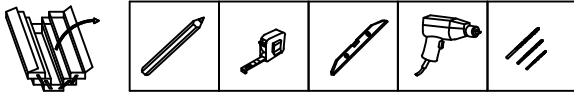
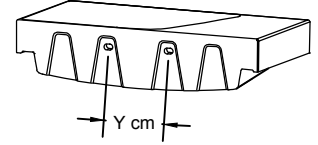
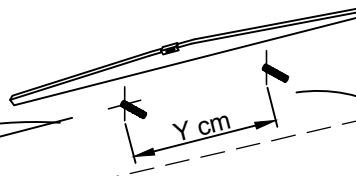

17

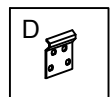
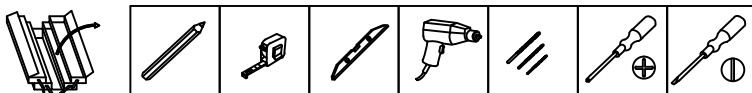
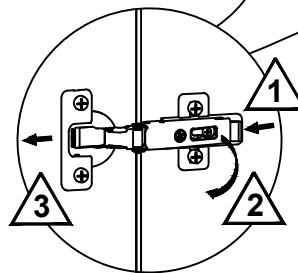
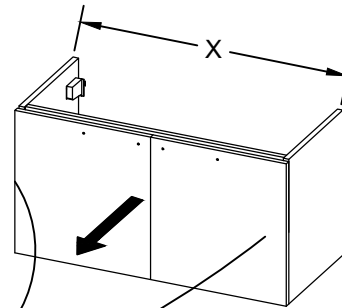
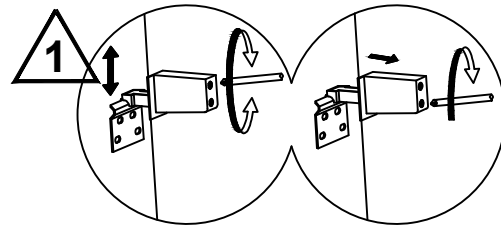
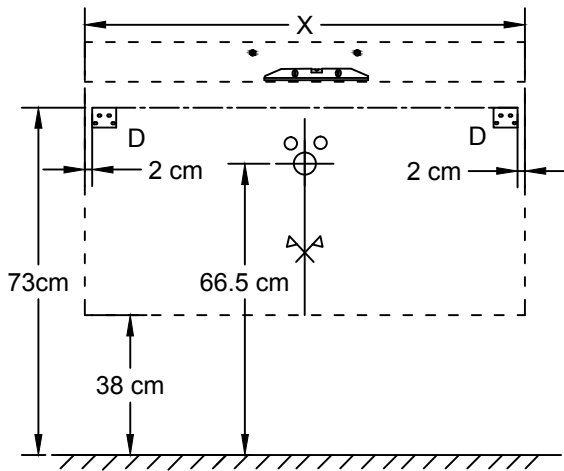

18

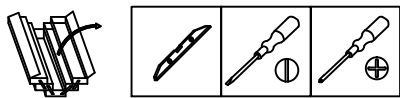
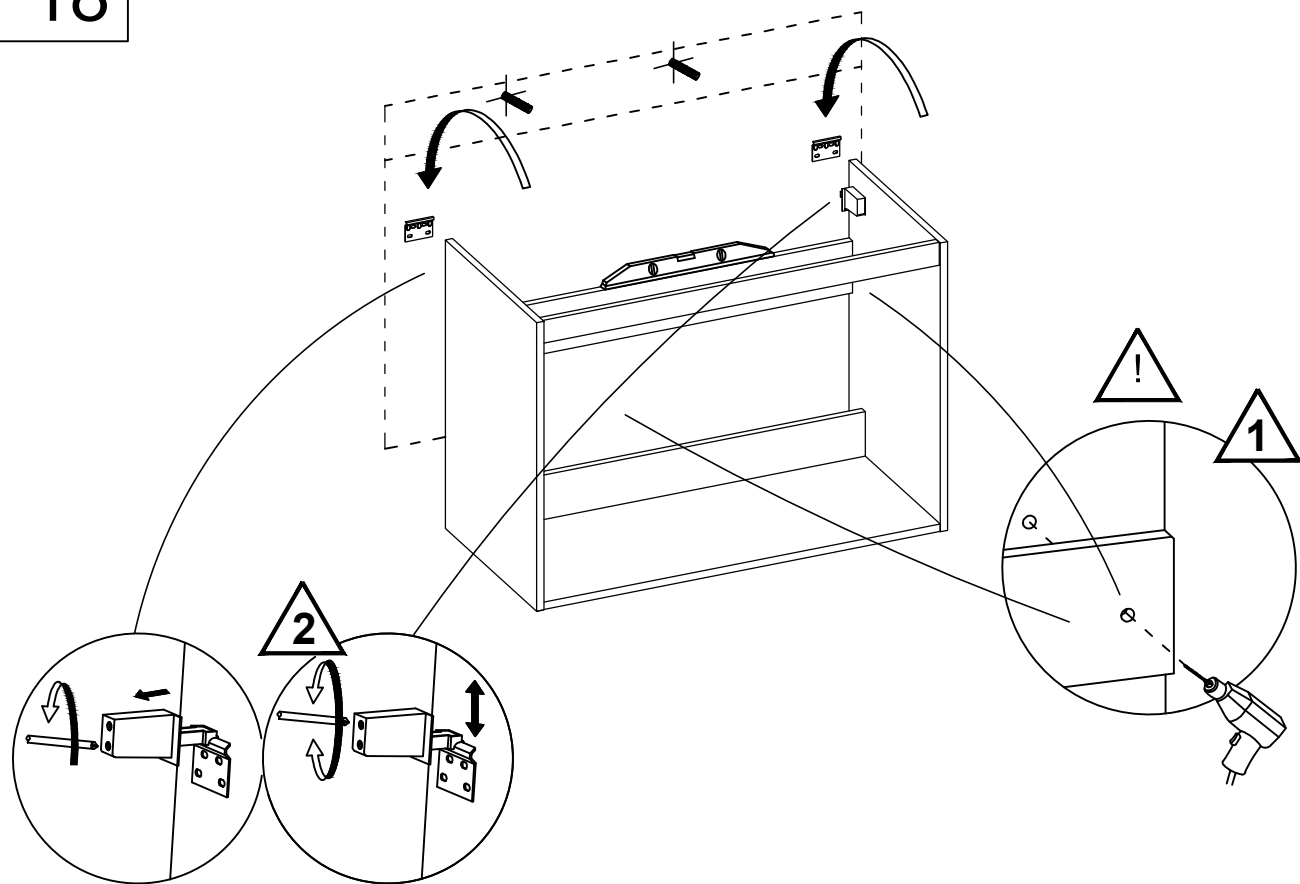

19

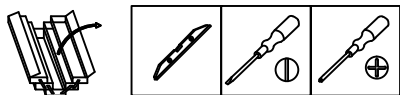
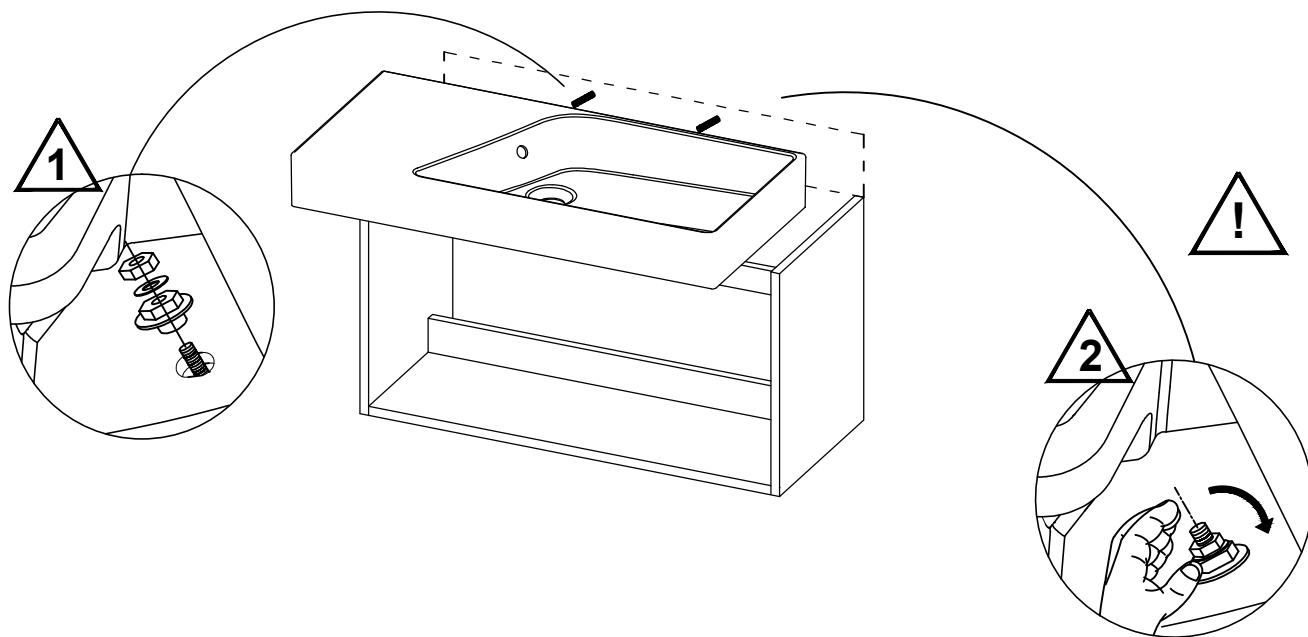

20

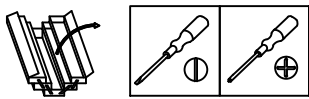
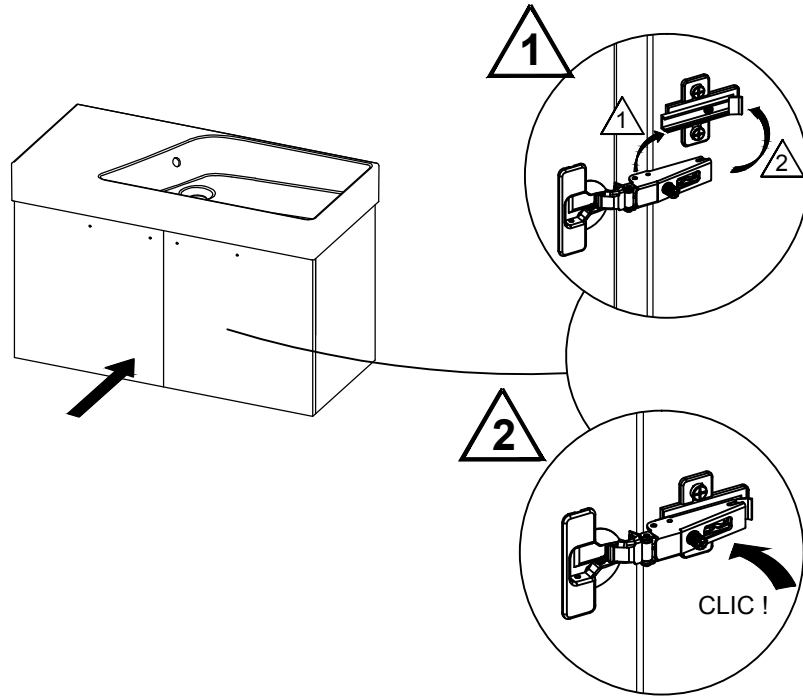

21

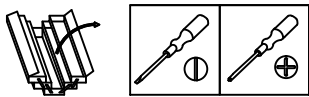
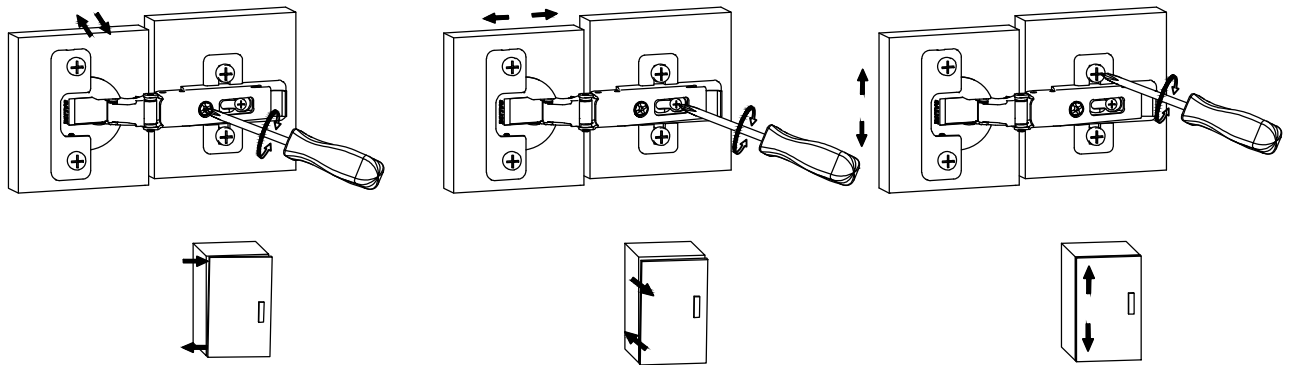

22

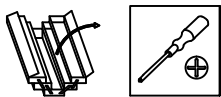
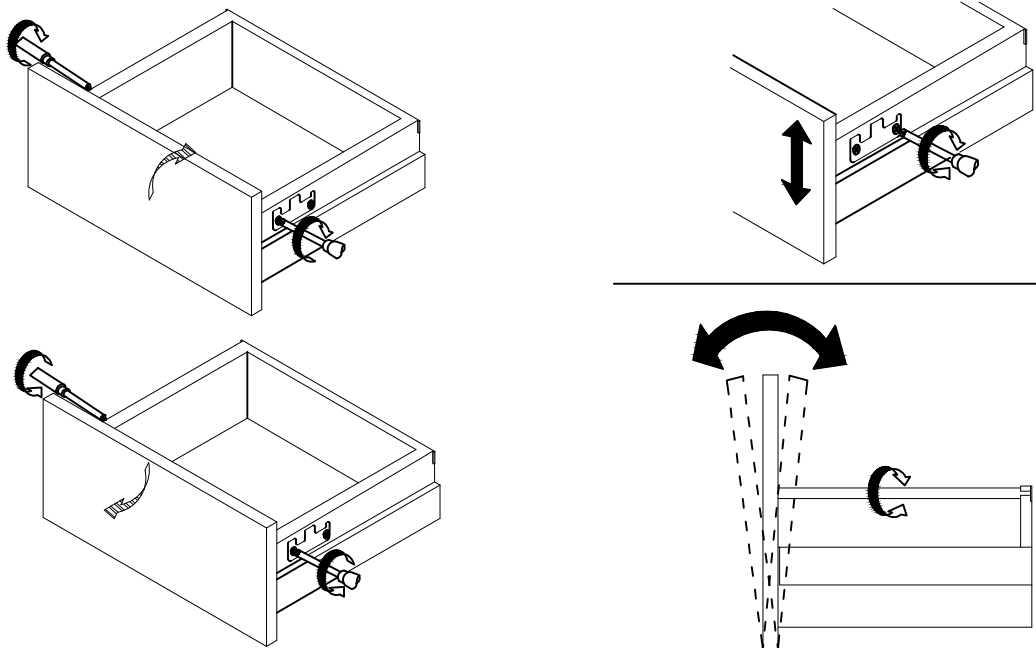

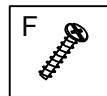
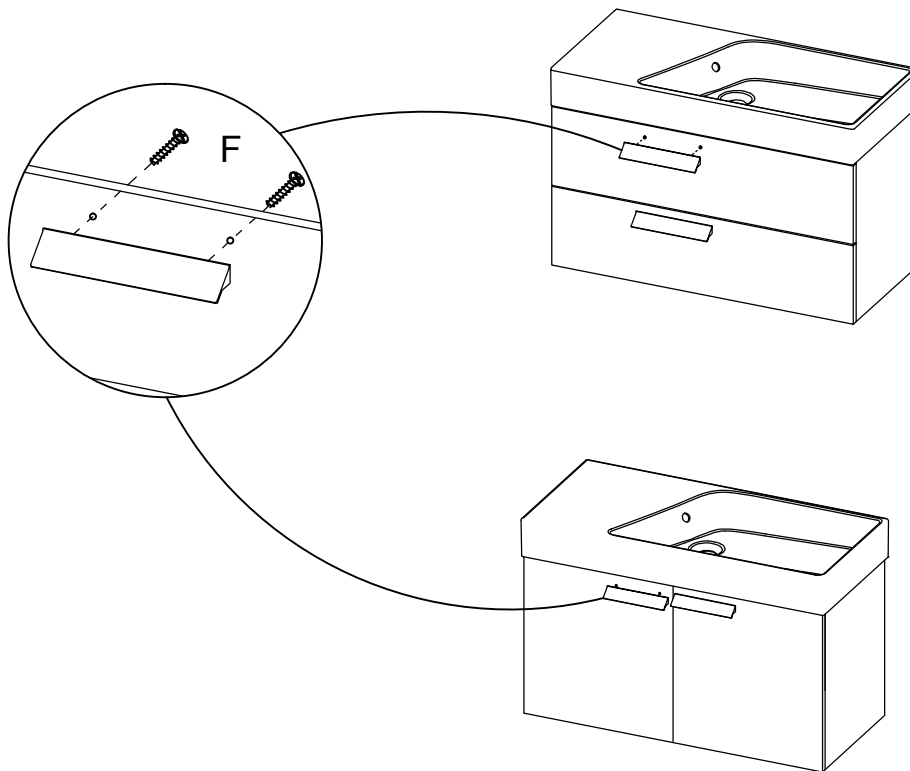
**JACOB DELAFON España**

Ctra. Logroño, km 17
50629 SOBRADIEL
ZARAGOZA
<http://www.jacobdelafon.com/es/index.jde>
Tél : +34 902 46 46 86

KOHLER / JACOB DELAFON

207, Angle Boulevard d'Anfa
20 000 CASABLANCA
<http://www.jacobdelafon.com/ma/index.jdf>
Tél : +212 2 295 9740

KOHLER UK

Cromwell Road
Cheltenham
GL525EP Gloucestershire
UNITED KINGDOM
<http://www.kohler.co.uk>
Tél : +44 (0)844 571 0048

SAV JACOB DELAFON FRANCE/BENELUX

ZI des Ecrevolles
10000 TROYES
assteclsav@kohlereupe.com
<http://www.jacobdelafon.com>
Tel : 03.25.70.91.25.
Fax : 03.25.81.49.09

KOHLER DEUTSCHLAND

Kohler GmbH
Vertriebsniederlassung Jacob Delafon
Postfach 1260 / 45733 Oer-Erkenschwick
www.jacobdelafon.de
Tel: +49 (0) 231 9860 430
Fax: +49 (0) 231 9860 425
customerservice.kohlergmbh@kohlereurope.com

KOHLER MIDDLE EAST

Al Thuraya Tower 2
9th Floor, Office 905
P.O. Box 500431
DIC, Dubai, UAE
<http://www.me.kohler.com/eu/index.htm>
Tél : +971-4-3624650

КОЛЕР РУС / KOHLER RUS

Ул. 1-я Бородинская, д.2а
Офис 147
121059 МОСКВА
РОССИЯ
<http://www.jacobdelafon.ru>
Тел.: +7 495 783 5223