

Тумба Ненси/ Bedside table NANCY

Код ТН ВЭД ЕАЭС

9403 60 100 1
9403 90 300 0



отрезать
и приклеить

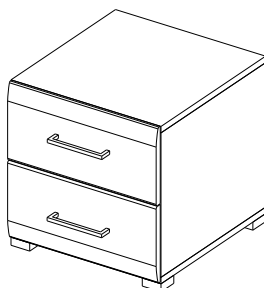

400	410	430

Craft gold - Крафт золотой
Ash light - Ясень светл

корпус
39НВТ1 / 2555
39НЯТ1 / 2577
39НАН08 / 3429
фасад
39ФБТ1 / 2588
39ФУТ1 / 2822

Комплектовочная ведомость/Set package sheet

Упак/ Package	Наименование	Description	Décor			Размер/ Size, mm	Кол-во/ Quantity	№	
			Wenge	Ash light	Craft gold				
1	Фурнитура	Furniture/Cabinetry hardware	-	-	-	-	1		
2	Боковина левая	Side left	Wenge	Ash light	Craft gold	358x410	1	1	
	Боковина правая	Side right				358x410	1	2	
	Крыша верхняя	Top high				400x414	1	3	
	Крыша нижняя	Top low				400x410	1	4	
	Детали ящика	Side drawers				100x400	4	6	
	Детали ящика	Side drawers				100x308	4	7	
	ХДФ	Back element				White	400x340	2	8
	ХДФ	Back element				White	372x396	1	9

Продается отдельно/Sold separately:

Упак/ Package	Наименование	Description	Décor		Размер/ Size, mm	Кол-во/ Quantity	№
			White gl	Cappuccino gl			
1	Панель	Drawer panel	White gl	Cappuccino gl	192x396	2	5

1		2		73		48		2x20	14		3,5x30
	8 x		8 x		8 x		15 x				4 x
5		7x50	126	C42 128 mm	72		6		6,3x10,5	38	
	12 x		2 x		8 x		8 x				4 x
15		24		400 mm	18						3,5x15
	1 x		2 x				20 x				

2

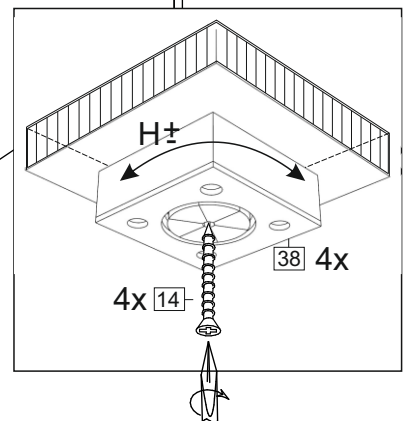
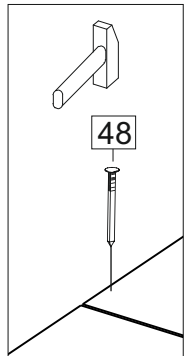
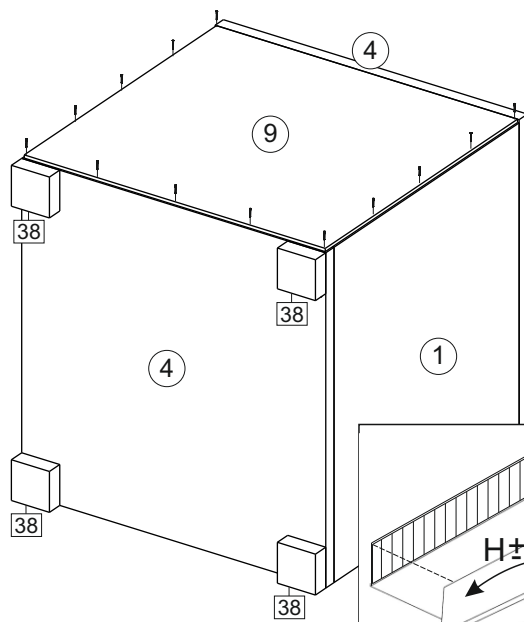
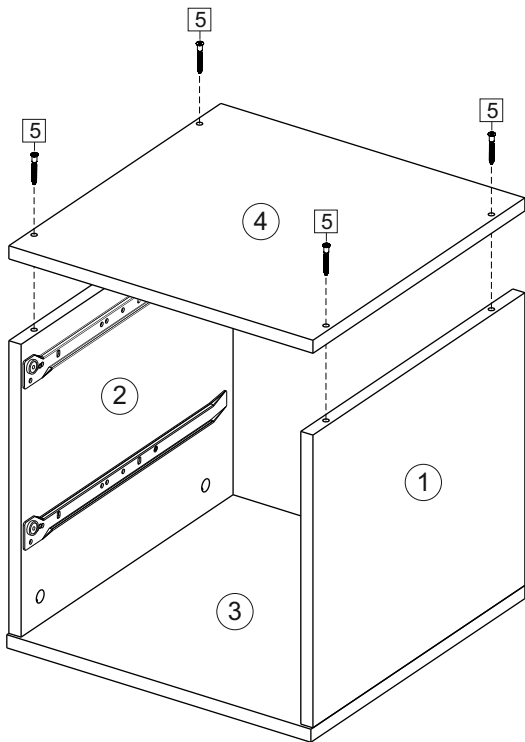
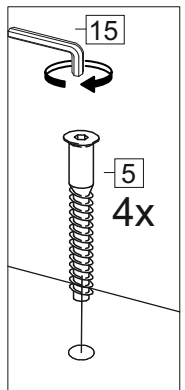
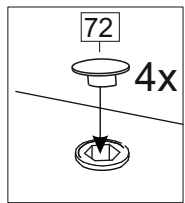
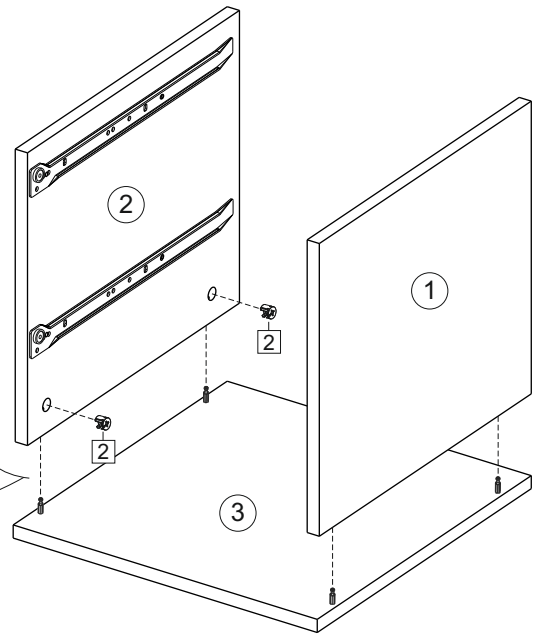
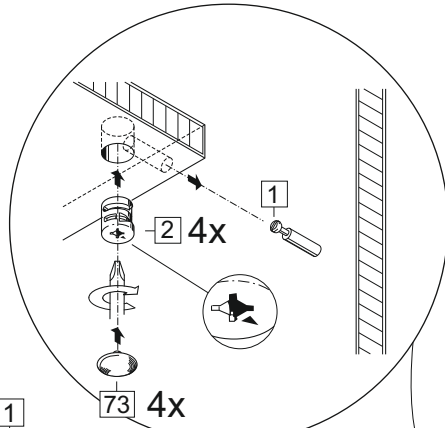
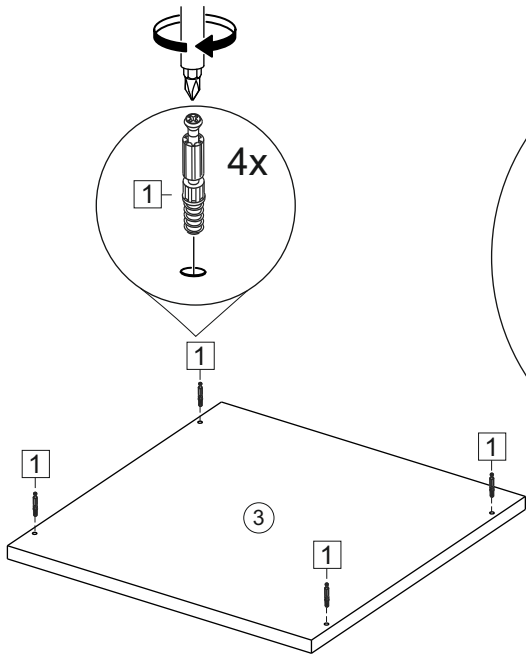
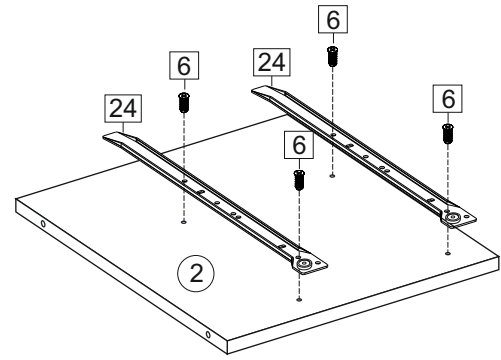
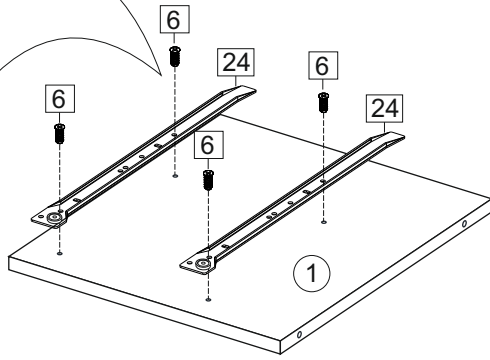
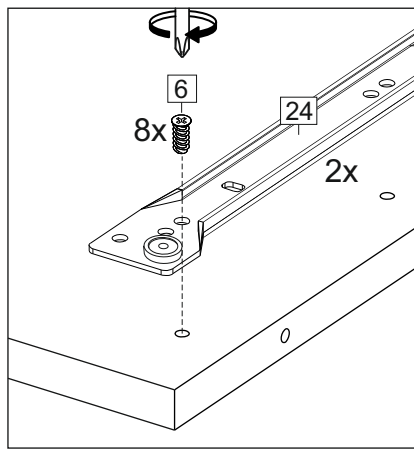

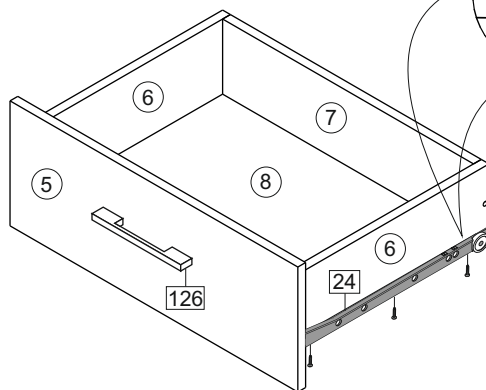
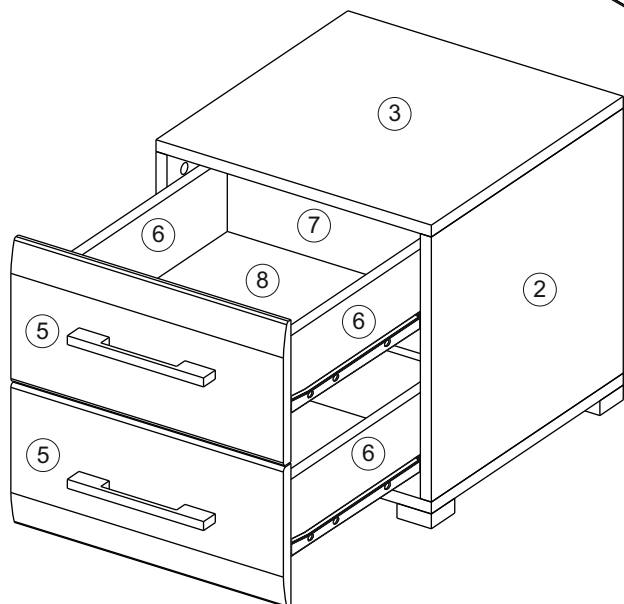
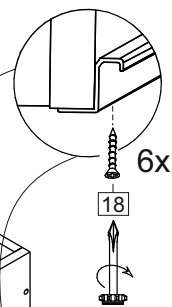
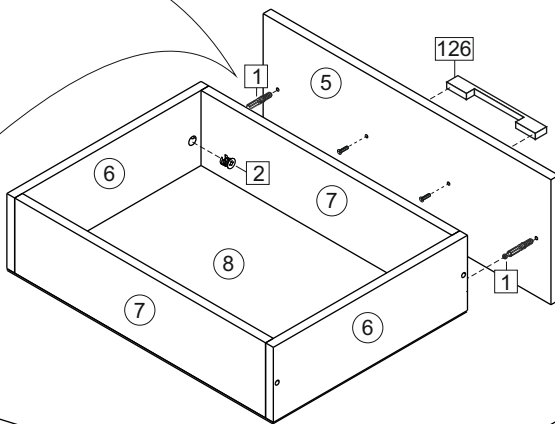
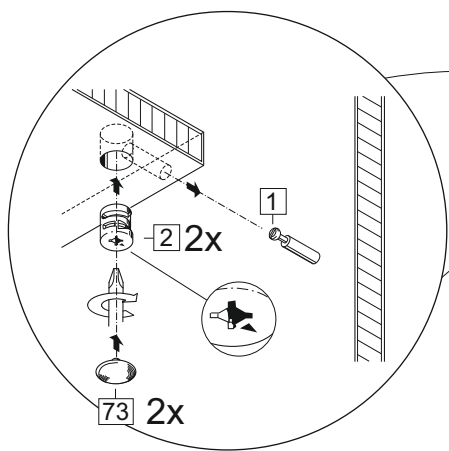
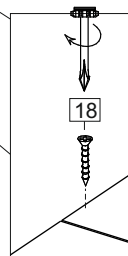
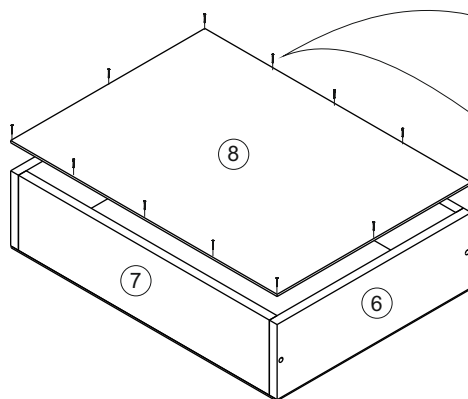
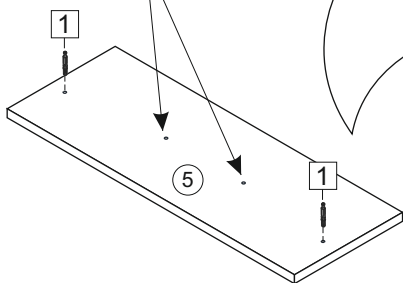
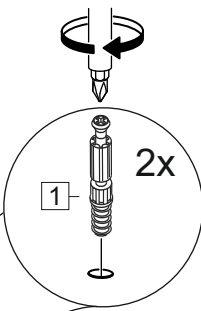
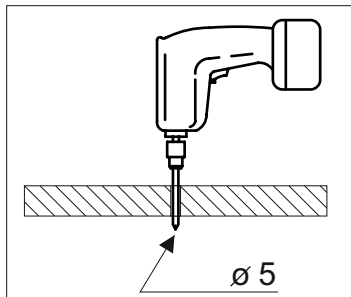
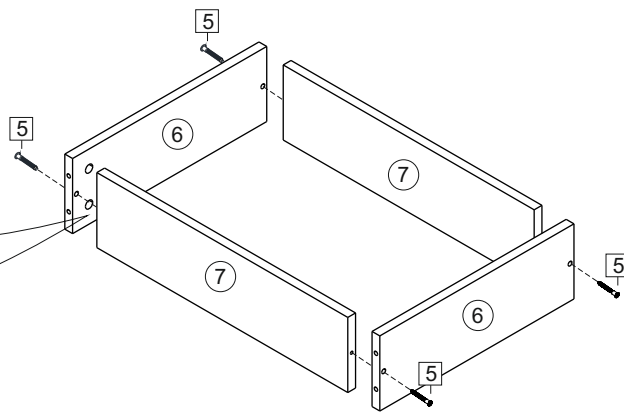
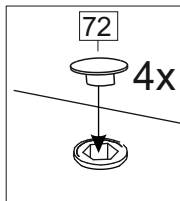
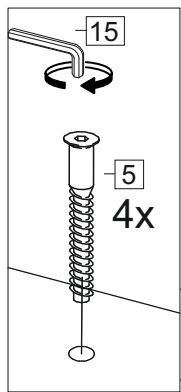

(PL) Instrukcja montażu

(CZ) Návod k montáži

(D) Montageanleitung

(GB) Assembly instruction

(F) Model d'emploi

(HU) Szerelési útmutató

(I) Istruzione di montaggio

(NL) Handleiding voor de montage



(RU) Инструкция по монтажу

(RO) Instrucțiuni de montare

(SK) Návod k montáži

(TR) Montaj talimatı

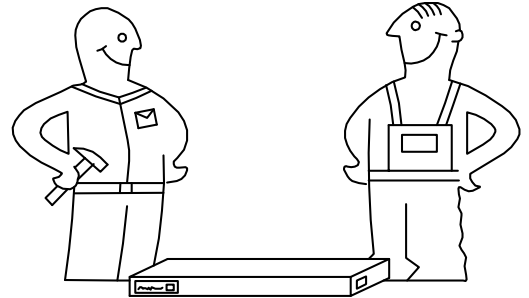
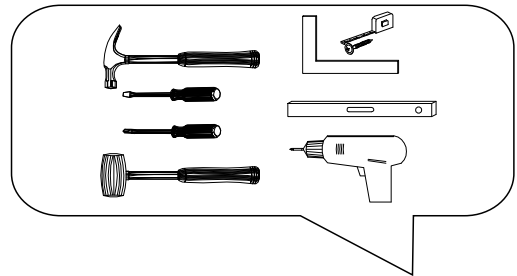

⚠ Uwaga • Upozornění • Achtung • Attention • Caution • Figyelem ⚠ Attenzione • Opgelet • Внимание • Atenție • Upozornenie • Dikkat	
PL	Czyszczenie należy wykonać wyłącznie za pomocą ściereczki lub lekko nawilżonego ręcznika. Nie stosować środków czyszczących do szorowania.
CZ	Čistění je nutné vykonávat výhradně pomocí utěrky nebo lehce navlhčeného ručníku. Nepoužívejte čističí prostředky obsahující abrazivní částice.
D	Bitte nur mit einem Staubtuch oder leicht feuchtem Lappen reinigen. Keine scheuernden Putzmittel verwenden.
GB	Please only clean with a duster or a damp cloth. Do not use any abrasive cleaners.
F	Le nettoyage se fait uniquement à l'aide d'un torchon ou d'une serviette légèrement mouillée.
HU	A tisztítás kizárólag törülköh vagy enyhén nedvesített törölköző segítségével végezhető. Súroló hatású tisztítószerket nem szabad használni.
I	Pulire esclusivamente con un panno o un asciugamano umido.
NL	Reinig alleen met een stofdoek of een lichtjes vochtige doek. Gebruik geen schurende poetsmiddelen.
RU	Очищайте от пыли тряпкой или слегка влажной ветошью. Не допускается применение чистящих средств, не предназначенных для ухода за мебелью.
RO	Curățarea trebuie efectuată numai cu o cârpă sau cu un prosop ușor umezit. Nu utilizați agenți de curățare abrazivi.
SK	Čistení je nutné vykonávať výhradne pomocí utierky alebo ľahko zvlhnutým ručníkom. Nepoužívajte čistiace prostriedky obsahujúce abrazívne častice.
TR	Lütfen sadece bir toz bezilye veya hafif nemli yumuşak bir bezle siliniz. Aşındırıcı temizlik malzemeleri kullanmayınız.

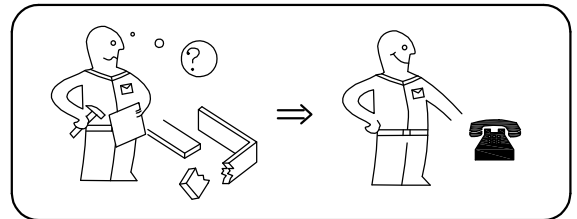
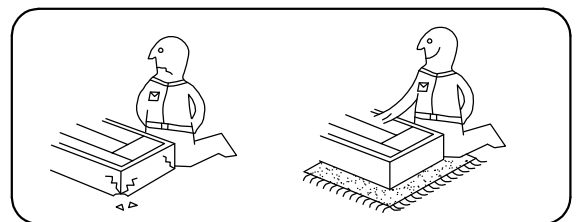

**Karta serwisowa • Servisní list • Service Karte • Service card • Carte de service • Szervizkártya
Scheda di servizio • Service kaart • Сервисная карта • Fisa service • Servisný list • Servis karti**

