

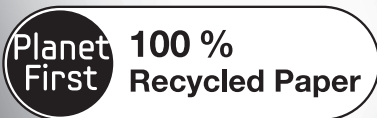

NV70*33 Series
NV66*33 Series

Built-in Oven

user & installation manual



This manual is made with 100 % recycled paper.

imagine the possibilities

Thank you for purchasing this Samsung product.



contents

USING THIS MANUAL

4

04 Using this manual

SAFETY INSTRUCTIONS

4

04 Safety instructions

MAINTENANCE

8

08 Bulb exchange

INSTALLATION

9

10 Door removal
10 Door glass removal

ENVIRONMENT

11

11 Auto energy saving function
11 Energy saving tip
11 Correct Disposal of This Product
(Waste Electrical & Electronic Equipment)

OVEN CONTROLS

12

12 Oven controls

ACCESSORIES

12

12 Accessories

INITIAL CLEANING

14

14 Initial cleaning

USING THE OVEN

14

14 Step 1. Select the cooking mode
14 Step 2. Set temperature
14 Useful auto speed preheating

English - 2

TIME SETTING

15

- 15 Set time
- 15 Set cook timer
- 15 Set end timer
- 16 Set delay start
- 16 Set kitchen timer

OTHER SETTINGS

16

- 16 Tone signal
- 16 Oven light
- 16 Child lock
- 16 Switch off

COOKING FUNCTIONS

17

- 17 Cooking functions

COOKING GUIDE

18

- 18 Poultry (Chicken/Duck)
- 18 Meat (Beef/Pork/Lamb)
- 19 Fish
- 19 Dishes
- 19 Grill
- 20 Baked goods
- 21 Frozen ready-meal

AUTOMATIC COOKING

22

- 22 Auto cook programmes

CLEANING AND CARES

25

- 25 Steam cleaning (depending on model)
- 25 Catalytic enamel surface (depending on model)
- 26 Hand cleaning
- 26 Water collector cleaning (depending on model)
- 26 Detaching the side runners (depending on model)
- 27 Attaching the side catalyst (depending on model)
- 27 Cleaning the ceiling (depending on model)
- 28 Troubleshooting
- 28 Information codes

TEST DISHES

29

- 29 Test dishes

using this manual

Thank you for choosing SAMSUNG Built - In Oven.

This User Manual contains important information on safety and instructions intended to assist you in the operation and maintenance of your appliance.

Please take the time to read this User Manual before using your oven and keep this book for future reference.

The following symbols are used in the text of this User Manual:



WARNING or CAUTION



NOTE or INFORMATION

safety instructions

Installation of this oven must be performed only by a licensed electrician. The installer is responsible for connecting the appliance to the mains power supply in observance of the relevant safety recommendations.

WARNING

This appliance is not intended for use by persons (including children) with reduced physical, sensory or mental capabilities, or lack of experience and knowledge, unless they have been given supervision or instruction concerning use of the appliance by a person responsible for their safety.

Children should be supervised to ensure that they do not play with the appliance.

If the supply cord is defective, it must be replaced by a special cord or assembly available from the manufacturer or an authorized service agent. (Fixed wiring type model only)

If the supply cord is damaged, it must be replaced by the manufacturer, its service agent or similarly qualified persons in order to avoid a hazard.
(Power cord type model only)

This Appliance should be allowed to disconnection from the supply after installation. The disconnection may be achieved by having the plug accessible or by incorporating a switch in the fixed wiring in accordance with the wiring rules.

The method of fixing is not to depend on the use of adhesives since they are not considered to be a reliable fixing means.

During use the appliance becomes hot. Care should be taken to avoid touching heating elements inside the oven.

⚠ **WARNING:** Accessible parts may become hot during use. Young children should be kept away.

If this appliance has steam or self cleaning function, excess spillage and all utensils must be removed before using the cleaning or self cleaning options.

If this appliance has self cleaning functions, during self cleaning the surfaces may get hotter than usual and children should be kept away.
(Cleaning function model only)

Only use the temperature probe recommended for this oven. (Temperature sensing probe model only)

A steam cleaner is not to be used.

⚠ **WARNING:** Ensure that the appliance is switched off before replacing the lamp to avoid the possibility of electric shock.

Do not use harsh abrasive cleaners or sharp metal scrapers to clean the oven door glass since they can scratch the surface, which may result in the glass shattering.

⚠ **WARNING:** The appliance and its accessible parts become hot during use.
Care should be taken to avoid touching heating elements. Children less than 8 years of age shall be kept away unless continuously supervised.

This appliance can be used by children aged from 8 years and above and persons with reduced physical, sensory or mental capabilities or lack of experience and knowledge if they have been given supervision or instruction concerning use of the appliance in a safe way and understand the hazards involved. Children should not play with the appliance. Cleaning and user maintenance should not be made by children without supervision.

The temperature of external surfaces may be high when the appliance is operating.

The door or the outer surface may get hot when the appliance is operating.

Keep the appliance and its cord out of reach of children less than 8 years.

Appliances are not intended to be operated by means of an external timer or separate remote-control system.

Please put the bent up frame side to the back, in order to support the rest position when cooking large loads.
(Depending on model)

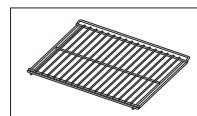

⚠ CAUTION

If the oven has been damaged in transport, do not connect it.

This appliance must be connected to the mains power supply only by a specially licensed electrician.

In the event of a fault or damage to the appliance, do not attempt to operate it.

Repairs should be performed by a licensed technician only. Improper repair may result in considerable danger to you and others. If your oven needs repair, contact a SAMSUNG Service Centre or your dealer.

Electrical leads and cables should not be allowed to touch the oven.

The oven should be connected to the mains power supply by means of an approved circuit breaker or fuse. Never use multiple plug adapters or extension leads.

The power supply of the appliance should be turned off when it is being repaired or cleaned.

Take care when connecting electrical appliances to sockets near the oven.

If this appliance has a steam cooking function, do not operate this appliance when the water supply cartridge is damaged. (Steam function model only)

When the cartridge is cracked or broken, do not use it and contact your nearest service center. (Steam function model only)

This oven has been designed only for the cooking of household foods.

During use, the oven interior surfaces become hot enough to cause burns. Do not touch heating elements or interior surfaces of the oven until they have had time to cool.



Never store flammable materials in the oven.



The oven surfaces become hot when the appliance is operated at a high temperature for an extended period of time.

When cooking, take care when opening the oven door as hot air and steam can escape rapidly.

When cooking dishes that contain alcohol, the alcohol may evaporate due to the high temperatures and the vapor can catch fire if it comes into contact with a hot part of the oven.

For your safety, do not use high-pressure water cleaners or steam jet cleaners.

Children should be kept at a safe distance when the oven is in use.
Frozen foods such as pizzas should be cooked on the big grid. If the baking tray is used, it may become deformed due to the great variation in temperatures.
Do not pour water into the bottom of the oven when it is hot. This could cause damage to the enamel surface.
The oven door must be closed during cooking.
Do not line the bottom of the oven with aluminum foil and do not place any baking trays or tins on it. The aluminum foil blocks the heat, which may result in damage to the enamel surfaces and cause poor cooking results.
Fruit juices will leave stains, which can become permanent on the enamel surfaces of the oven. When cooking very moist cakes, use the deep pan.
Do not rest bake ware on the open oven door.
Keep children away from the door when opening or closing it as they may bump themselves on the door or catch their fingers in the door.
Do not step, lean, sit or place heavy items on the door.
Do not open the door with unnecessarily strong force.
 WARNING: Do not disconnect the appliance from the main power supply even after the cooking process is completed.
 WARNING: Do not leave the door open while oven is cooking.

	Символ «не для пищевой продукции» применяется в соответствии с техническим регламентом Таможенного союза «О безопасности упаковки» 005/2011 и указывает на то, что упаковка данного продукта не предназначена для повторного использования и подлежит утилизации. Упаковку данного продукта запрещается использовать для хранения пищевой продукции.
	Символ «петля Мебиуса» указывает на возможность утилизации упаковки. Символ может быть дополнен обозначением материала упаковки в виде цифрового и/или буквенного обозначения.

ЭНЕРГЕТИЧЕСКАЯ ЭФФЕКТИВНОСТЬ	
Класс энергоэффективности	A
Потребление электроэнергии, кВт·ч стандартный разогрев	0.89
принудительная циркуляция воздуха (при стандартной загрузке)	0.79
Полезный объем жарочного электрошкафа V, л	Серия NV70*33 : 70 л Серия NV66*33 : 66 л
Тип полезного объема жарочного электрошкафа, л	большой
Адрес и наименование лаборатории	(Мэтан-донг) 129, Самсунг-ро, Йонгтонг-гу, Сувон-си, Гйонги-до, Корея, 443-742
Характеристики энергетической эффективности определены согласно Приказу Министерства промышленности и торговли РФ от 29 апреля 2010 г. № 357	
На продукте присутствует наклейка с информацией о его энергетической эффективности	
※ оборудование класса I	

English - 7

maintenance

BULB EXCHANGE

⚠ WARNING

- Before replacing any of the oven bulbs, switch oven off and disconnect the oven from the mains.
- Bulbs can be purchased from the SAMSUNG Service Centre.

Rear oven light

⚠ Use a lamp with a 25-40 watt/220~240 V, 300 °C heat-resistant oven light for replacement.

1. Remove cap by turning anti-clockwise and remove the metal ring and sheet ring. If necessary, replace the oven light.
2. Clean the glass cap, the metal ring and the sheet ring if necessary.
3. Fit the metal and the sheet ring to the glass cap.
4. Replace glass cap where you have removed it in step 1 and turn it clockwise to keep it in place.

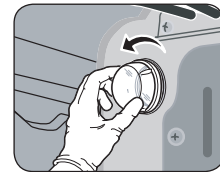

Side oven light (Depending on model)

⚠ Use a lamp with a 40 watt/220~240 V, 300 °C heat-resistant oven light for replacement.

1. To remove the glass cover, hold the lower end with one hand, insert a flat sharp implement such as a table knife between the glass and the frame.
2. Pop out the cover and if necessary, replace the oven light.
3. Re-attach the glass cover.

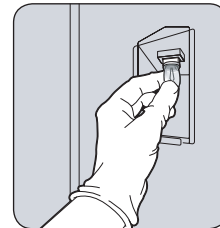
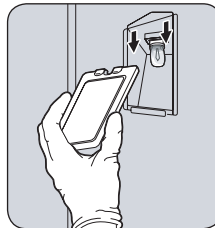
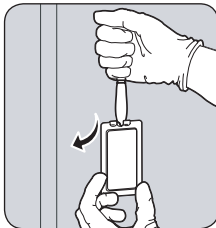

📌 **TIP:** Always use a dry cloth when handling a halogen bulb to prevent sweat from fingers being deposited on the bulb surface. It increases the life of the bulb when you exchange the bulb.

installation

⚠ Safety instructions for installation

This oven may be installed only by an approved electrician. The installer is responsible for connecting the appliance to the main supply, while observing the relevant safety regulations.

- Ensure protection from live parts when installing the oven.

Power connection

If the appliance is not connected to the mains with a plug, a multi-pole isolator switch (with at least 3 mm contact spacing) must be provided in order to satisfy safety regulations. The power cable (H05 RR-F or H05 VV-F, min. 1.5~2.5 mm²) must be of sufficient length to be connected to the oven, even if the oven stands on the floor in front of its built-in cabinet. Open the rear connection cover of the oven with a screwdriver and loosen the screws of the cable clamp before you connect the power lines to the relevant connection terminals. The oven is earthed via the (⏏)-terminal. The yellow and green cable (earth connection) must be connected first and be longer than the others. If the oven is connected to the mains with a plug, this plug must remain accessible after the oven is installed. Samsung will take no responsibility for accidents that originate from a missing or faulty earth connection.

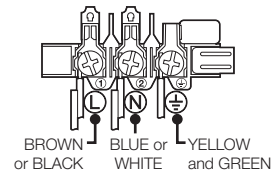

- ⚠ **WARNING:** Do not allow the connecting cable to become trapped during installation, and prevent it coming into contact with hot parts of the oven.

Installation in the cabinet

With built-in furniture, plastic surfaces and adhesive for the oven should be resistant to 90 °C inside of the furniture and to 75 °C for adjacent furniture. Samsung will take no responsibility for damage of plastic surfaces or adhesive from the heat.

There should be a ventilation gap in the base of the kitchen cabinet where the oven is to be placed. For ventilation, a gap of about 50 mm should be left between the lower shelf and the supporting wall. If the oven is to be installed below a hob, the hob's installation instructions should be followed.

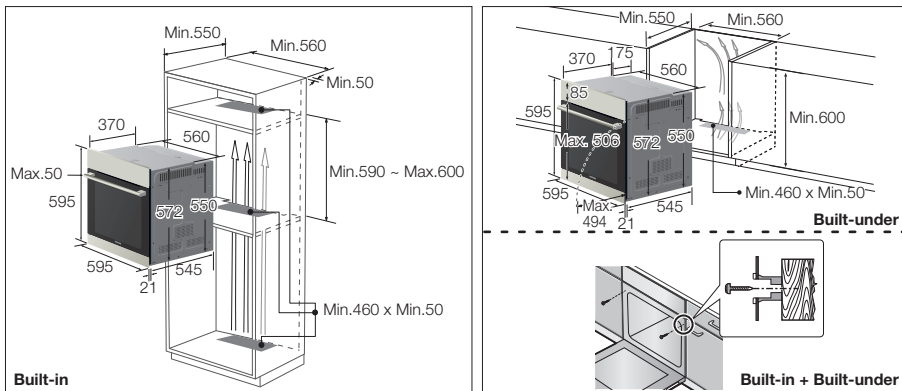

Push the appliance completely into the cabinet and fix the oven firmly on both sides using 2 screws. Make sure that a gap of at least 5 mm should be left between the appliance and the adjacent cabinet.

After installation, remove the vinyl protective film, tape, paper and accessories from the door and inside of oven. Before uninstalling the oven from the furniture, disconnect the oven from the power supply and release the 2 screws on the both sides of the oven.

- ⚠ **WARNING:** The built-in furniture must have a minimum ventilation gap for Air-flow as shown in picture. Do not cover this hole with strips of wood, for this is used to provide ventilation.

- 🔧 The front exterior of the oven such as handle is different model by model. But the size of the oven in the picture is same.

DOOR REMOVAL

For normal use, the oven door must not be removed but if removal is necessary, for example, for cleaning purposes, follow these instructions.

⚠ WARNING: The oven door is heavy.

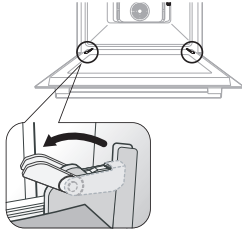

1. Open the door and flip open the clips at both hinges completely.

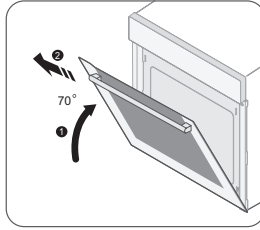

2. Close the door by approximately 70°. With both hands, grasp the sides of the oven door at its middle and lift and pull upwards until the hinges can be taken out.

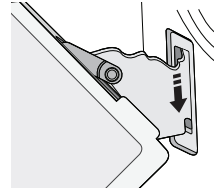

3. After cleaning, to attach the door repeat steps 1 and 2 in reverse order. The clip on the hinge should be closed on both sides.

DOOR GLASS REMOVAL

The oven door is equipped with three sheets of glass placed against each other. These sheets can be removed for cleaning.

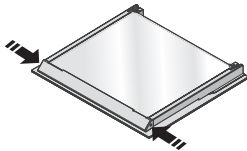

1. Press both buttons on the left and right sides of the door.

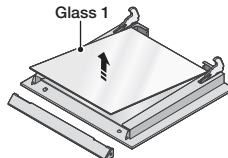

2. Detach the covering and remove glass 1 and 2 from the door.

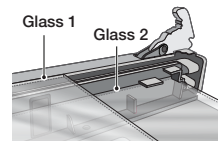

3. After cleaning the door glasses, for assembly repeat 1, 2 steps in reverse order. Check the correct position of glass 1 and 2 with above picture.

📝 ATTACHING: When assembling the glass 1, the screen printed surface of the glass 1 should be on the inside, between the glass sheets.

AUTO ENERGY SAVING FUNCTION

- If you do not select any function when appliance is in the middle of setting or operating with temporary stop condition, function is cancelled and clock will be displayed after 10 minutes.
- Light : During cooking process, you can switch off Oven lamp by pressing 'Oven light' button. For energy saving, the oven lighting is switched off a few minutes after cooking program has started.

ENERGY SAVING TIP

- During cooking, the oven door should be closed except for turning food over. Please do not open the door frequently during cooking to keep the temperature in cavity and it will save the energy and time.
- If cooking time is more than 30 minutes, you can switch off the oven 5-10 minutes before the end of the cooking time for energy saving. The residual heat will complete the cooking process.
- After completing one cooking, if you succeed to another cooking before oven cools off, you can reduce energy and time for re-heating the oven.



CORRECT DISPOSAL OF THIS PRODUCT (WASTE ELECTRICAL & ELECTRONIC EQUIPMENT)

(Applicable in countries with separate collection systems)

This marking on the product, accessories or literature indicates that the product and its electronic accessories (e.g. charger, headset, USB cable) should not be disposed of with other household waste at the end of their working life. To prevent possible harm to the environment or human health from uncontrolled waste disposal, please separate these items from other types of waste and recycle them responsibly to promote the sustainable reuse of material resources.

Household users should contact either the retailer where they purchased this product, or their local government office, for details of where and how they can take these items for environmentally safe recycling.

Business users should contact their supplier and check the terms and conditions of the purchase contract. This product and its electronic accessories should not be mixed with other commercial wastes for disposal.

Подлежит использованию по назначению
в нормальных условиях
Срок службы: 7 лет

oven controls

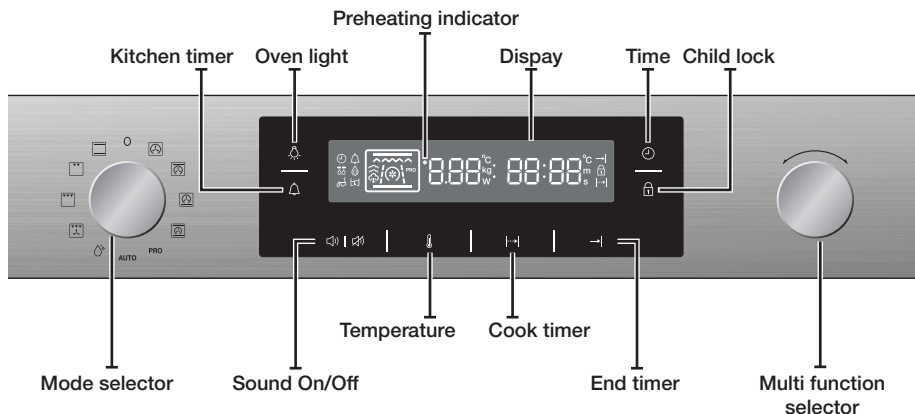

Front design

The front panel is available in various material and color options including stainless steel, white, black, beige and glass. For purposes of quality improvement, the appearance may be subject to change.

accessories

Your new Samsung oven comes with a lot of accessories that should become very helpful during the preparation of different meals. The following accessories are supplied differently model by model.



WARNING

- Be sure to attach the accessory correctly to the shelf level inside of the oven. Trays need to have at least 2 cm space towards the bottom of the oven, otherwise the enamel surface could be damaged.
- Be very careful removing meals and/or accessories out of the oven. Hot meals, accessories and surfaces can burn you.



The accessories can become deformed when they become hot. When they have cooled down, the deformation disappears with no effect on the function.

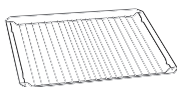

Wire shelf

The wire shelf should be used for grilling and roasting meals. You could use it with casseroles and other baking pots. Please put the bent up frame side to the back, in order to support the reposition when cooking large loads.

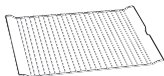

Wire tray insert (Depending on model)

The wire tray insert should be used for grilling and roasting meals. It can be used in combination with the tray to prevent liquids from dropping onto the bottom of the oven.



Baking tray (Depending on model)

The baking tray (Depth : 20 mm) could be used for the preparation of cakes, cookies and other pastries. Please put the slanted side to the front.



Universal tray (Depending on model)

The universal tray (Depth : 30 mm) could be used for the preparation of cakes, cookies and other pastries. And it is also good for roasting. It can be used in combination with the wire tray insert to prevent liquids from dropping onto the bottom of the oven. Please put the slanted side to the front.



Extra deep tray (Depending on model)

The extra deep tray (Depth : 50 mm) is also good for roasting. It can be used in combination with the wire tray insert to prevent liquids from dropping onto the bottom of the oven. Please put the slanted side to the front.



Rotisserie spit (Depending on model)

The rotisserie spit could be used for grilling such as chicken. The rotisserie spit can only be used in single mode on shelf level 3, because its spit has to be attached to an adapter on the back plane. Remove black plastic handle while cooking.

Rotisserie spit and Shashlik (Depending on model)

To use it :

- Place the tray (no trivet) at shelf level 1 to collect the cooking juices or on the bottom of the oven if the piece of meat to be roasted is too big.
- Slide one of the forks onto the spit; put the piece of meat to be roasted onto the spit;
- Parboiled potatoes and vegetables can be placed around the edge of the tray to roast at the same time.
- Place the cradle on the middle shelf and position with the "v" shape at the front.
- To help insert the spit, the handle can be screwed onto the blunt end.
- Rest the spit onto the cradle with the pointed end towards the back and gently push until the tip of the spit enters the turning mechanism at the back of the oven. The blunt end of the spit must rest on the "v" shape. (The spit has two lugs which should be nearest to the oven door so to stop the spit going forward, the lugs also act as a grip for the handle.)
- Unscrew the handle before cooking. After cooking screw the handle back on to help remove the spit from the cradle.

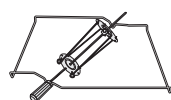

It is recommended that the spit accessories are used with food under 1.5 kg weight.

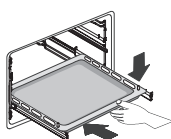

Telescopic rails (Depending on model)

- To insert the wire shelf or tray, first slide out the telescopic rails for one particular level.
- Place the wire shelf or tray on the rails and push them back completely into the oven. Close the oven door only after you have pushed the telescopic rails into the oven.

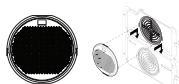

Grease filter (Depending on model)

The grease filter installed on the back oven interior wall protects the fan, round heater, and the oven from impurity, particularly spattering fat. When cooking meat, we recommend using the fat filter. When baking pastry, always remove the filter! If the filter is installed when baking pastry or cakes, the results can be quite poor.

initial cleaning

Before the oven is used for the first time, initial cleaning of the oven is required to remove the new oven smell.

1. Remove all accessories from the oven.
2. Run oven with convection 200 °C or conventional 200 °C for an hour. This procedure will burn any remaining production substances in the oven.
3. Switch off the oven by turning mode selector to off after an hour.

 For the first time use of the accessories, clean the accessories thoroughly with warm water, detergent and soft clean cloth.

using the oven

Your new oven has below basic steps for cooking.

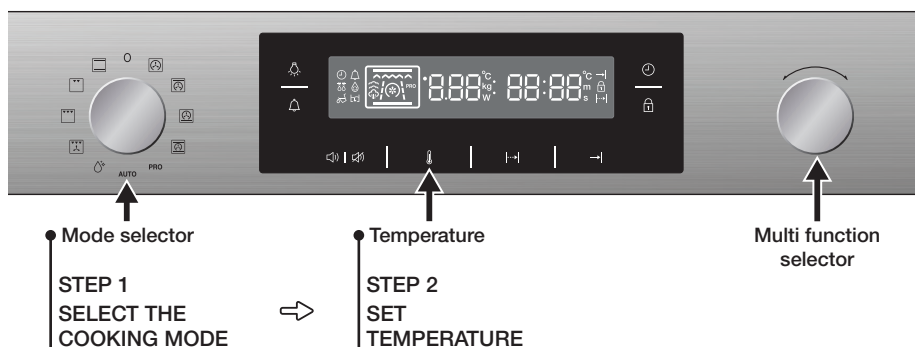



STEP 1. SELECT THE COOKING MODE

Select the cooking mode by turning the mode selector.

STEP 2. SET TEMPERATURE

The temperature can be set after setting the cooking function. Each cooking function has a different temperature range, refer to the cooking function part in the manual.

1. Press the  key, temperature figure will blink.
2. Turn the multi function selector to set desired temperature.
3. Press the  key again to finish the setting of temperature.

 During cooking, you can change the temperature in the same order as above.

USEFUL AUTO SPEED PREHEATING

Your oven offers cooking functions, which include a fast preheating stage.

This stage will be indicated beside temperature setting in the display.

During this preheating stage various heating elements are applied to speed up heating of the oven.

Even though you change temperature to higher, the oven automatically change target temperature and auto speed preheating will be applied. After the selected temperature is reached, the preheating indicator will disappear and a signal reminds you to insert the food into your oven.

time setting

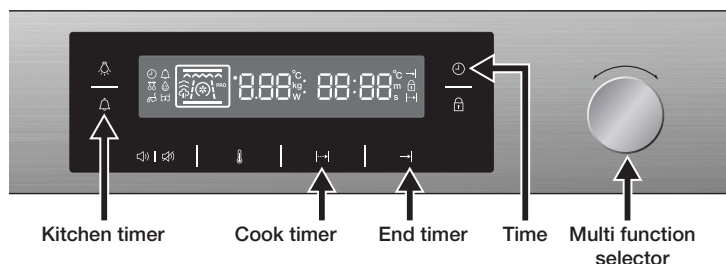

SET TIME

For the first time use of the oven or after power failure, time setting is required.

1. Press the key, hours figure will blink.
2. Turn the Multi function selector to set hours.
3. Press the key, minutes figure will blink.
4. Turn the Multi function selector to set minutes.
5. Press the key again to set the current time.



The desired time can be reset in the same order as above.
During cooking process, press key to see the current time.

SET COOK TIMER

After you set cooking function, you can select the cooking time.
After the cooking time is over, the heating elements automatically turn off.

1. Press key, cook timer figure will blink.
2. Turn the multi function selector to apply the desired time for cook timer.
3. Press key again.



The cook timer can be reset in the same order as above. When the set time is over, the display shows blinking "0:00" with a signal. You can set a new cook timer or turn off the oven.
To cancel the cook timer, press key and set the cook timer to zero.

SET END TIMER

After you set cooking function, you can set when the cooking time ends.
After the cooking time is over, heating elements automatically turn off.

1. Press key, end timer figure will blink.
2. Turn the Multi function selector to apply the time for end timer.
3. Press key again.





The end timer can be reset in the same order as above and when the set time is over, the display shows blinking "0:00" with a signal.
To cancel the end timer, press key and set the end timer to current time.

SET DELAY START

If the cook timer is entered after the end timer has already been set, the oven starts and stops operation automatically at the set time.

WARNING

- When you use delay start, do not leave the food for too long time in the oven as food may spoil.
- As delay start function is without pre-heating, cooking result can be a little different with normal cooking condition with pre-heating.

1. Press  key, end timer figure will blink.
2. Turn the multi function selector to apply the time for end timer.
3. Press  key, cook timer figure will blink.
4. Turn the multi function selector to apply the time for cook timer.
5. The delay start point is automatically calculated and the oven is waiting until delay start point.





Delay start will not be set in twin mode.

The cook timer, end timer and delay start can be set after cooking function setting.

SET KITCHEN TIMER

The kitchen timer can be set independently of the oven function and used with cook timer or end timer at the same time. The kitchen timer has it's own signal so you can recognise it from the others.

1. Press  key, kitchen timer figure will blink.
2. Turn the multi function selector, to apply the desired time for kitchen timer.
3. Press  key again.



To cancel the kitchen timer, press the hold  key for two seconds.

The kitchen timer can be reset in the same order as above and when the set time is over, the display shows blinking "0:00" with a signal.

other settings

TONE SIGNAL

 |  To activate or deactivate the tone signal, press and hold the  |  key for 3 seconds.

OVEN LIGHT



Press  key to turn on and off.

For energy saving, the oven light is switched off within a few minutes after the start of a cooking.

CHILD LOCK



To activate or deactivate the child lock function, press and hold  key for 3 seconds.

Display will show the  when the child lock function is activated. You can use the child lock function during cooking also. In this case all keys and multi function selector will not operate but you can switch off by turning the mode selector to off.

SWITCH OFF











When the oven has been switched off every heating element stops operating.

The cooling fan will continue to run for a while after the oven has been switched off for safety.

cooking functions

This oven offers below various functions.

Symbol	Function Temp Range	Use
	Conventional 40-250 °C	Heat is emitted from the top and bottom heating system. This function should be used for standard baking and roasting of almost any type of dishes. Suggested temperature : 200 °C
	Convection 40-250 °C	The heat generated by the convection is evenly distributed in the oven by fans. This function can be used for frozen dishes and baking. Suggested temperature : 170 °C
	Top + Convection 40-250 °C	The heat generated by the top heating system and the convection is evenly distributed in the oven by fans. This function can be used for roasting dishes that require a crispy topping eg. meat or lasagne. Suggested temperature : 190 °C
	Bottom + convection 40-250 °C	The heat generated by the bottom heating system and the convection is evenly distributed in the oven by fans. This function can be used for pizzas, bread and cakes. Suggested temperature : 190 °C
	Large grill 40-270 °C	Heat is emitted from the large area grill. This function can be used for browning the tops of food eg. meat, lasagne, gratin dishes. Suggested temperature : 240 °C
	Eco grill 40-270 °C	Heat is emitted from the small area grill. This function can be used for smaller dishes that need less heat, like fish and filled baguettes. Suggested temperature : 240 °C
	Fan grill 40-270 °C	The heat generated by the two top heating elements is distributed by the fan. This mode can be used for grilling meat and fish. Suggested temperature : 240 °C
	Intensive cook 40-250 °C	This mode activates all heating elements such as upper, lower and convection fan alternately. The heat is distributed evenly in the oven. This mode is suitable for big quantities of food, which need heat, such as large gratins and pies. Suggested temperature : 170 °C
PRO	ProRoasting 40-150 °C	This mode includes an automatic pre-heat cycle up to 220 °C. The top heater and the convection fan is operating during the process of searing the meat. After this stage the food is cooked gently by the low temperature selected. The top and bottom heaters are operating on this cycle. This mode is suitable for meat roasts, poultry and fish. Suggested temperature : 100 °C  Please start cooking without pre-heating.

cooking guide



INFORMATION



- We recommend to pre-heat the oven using all cooking modes except for some items specified in the cooking guide.
- When using the Eco Grill function, put food in the centre of accessory.







WARNING on ACRYLAMIDE

- If you have baked and fried food, Acrylamide may cause health problem. Acrylamide is mostly produced in starch such as potato chips, French fries, and bread that have been heated. Therefore we recommend that you cook at low temperature and do not cook until they are too dark.



POULTRY (CHICKEN/DUCK)

Food Item	Mode	Shelf level	Accessory	Temp. (°C)	Time (min.)
Whole chicken (800-1300 g)	Top+Convection 	2	Wire tray insert + Universal (deep) tray	190-220	45-65
Chicken pieces (500-1000 g)	Top+Convection 	4	Wire tray insert + Universal (deep) tray	200-220	25-35
Duck breast (300-500 g)	Top+Convection 	4	Wire tray insert + Universal (deep) tray Add 1 cup water	180-200	25-35



MEAT (BEEF/PORK/LAMB)

Food Item	Mode	Shelf level	Accessory	Temp. (°C)	Time (min.)
Beef steaks (400-800 g)	Large Grill 	4	Wire tray insert + Universal (deep) tray	240	1st side : 8-10 2nd side : 5-7
Roast beef (800-1200 g)	Top+Convection 	2	Wire tray insert + Universal (deep) tray Add 1 cup water	200-220	45-60
Pork on bone (1000 g)	Top+Convection 	3	Wire tray insert + Universal (deep) tray	180-200	50-65
Lamb rack (350-700 g)	Convection 	3	Wire tray insert + Universal (deep) tray	190-200	40-50



FISH

Food Item	Mode	Shelf level	Accessory	Temp. (°C)	Time (min.)
Roast fish (500 g-1000 g) Use ovenproof dish	Top+Convection 	2	Wire shelf	180-200	30-40
Whole fish (300-1000 g)	Conventional 	3	Wire tray insert + Universal (deep) tray	240	15-20
Fish filets (500-1000 g)	Conventional 	3	Baking (universal) tray	200	13-20















DISHES

Food Item	Mode	Shelf level	Accessory	Temp. (°C)	Time (min.)
Cannelloni / Lasagne (250-500 g) Use ovenproof dish	Bottom+Convection 	3	Wire shelf	180	22-30
Homemade pizza (500-1000 g)	Bottom+Convection 	2	Baking (universal) tray	200-220	15-25
Baked potato (500-1000 g)	Conventional 	3	Baking (universal) tray	180-200	30-45









GRILL

Food Item	Mode	Shelf level	Accessory	Temp. (°C)	Time (min.)
Sausages (thick) 5-10 pcs	Large Grill 	4	Wire tray insert + Universal (deep) tray	220	1st side : 5-8 2nd side : 5-8
Toast 5-10 pcs	Large Grill 	5	Wire shelf	240	1st side : 1-2 2nd side : 1-2
Cheese on toast 4-6 pcs	Large Grill 	4	Wire tray insert + Baking (universal) tray	200	4-8

BAKED GOODS

Food Item	Mode	Shelf level	Accessory	Temp. (°C)	Time (min.)
Sponge cake (250-500 g)	Conventional 	2	Wire shelf	160-180	20-30
Marble cake (500-1000 g)	Conventional 	2	Wire shelf	170-190	40-50
Yeast cake on tray with fruit & crumbles topping (1000-1500 g)	Conventional 	2	Baking (universal) tray	160-180	25-35
Muffins (500-800 g)	Conventional 	2	Wire shelf	190-200	25-30
Fresh croissant (200-400 g) (ready-dough)	Convection 	3	Wire shelf	180-200	15-25
Frozen puff pastry small pies with filling (300-600 g) No preheat necessary	Bottom+Convection 	3	Baking (universal) tray	180-200	20-25
Frozen yeast dough pie with apple (350-700 g)	Bottom+Convection 	3	Wire shelf	180-200	15-20
Yeast dough pies with filling (600-1000 g)	Bottom+Convection 	3	Baking (universal) tray	180-200	20-30
Homemade bread (700-900 g)	Bottom+Convection 	2	Wire shelf	170-180	45-55
Baked bananas (3-5 pcs)	Convection 	3	Wire shelf	220-240	15-25
Baked apples 5-8 pcs each 150-200 g	Convection 	3	Wire shelf	200-220	15-25
Apple & almond cake (500-1000 g)	Convection 	2	Wire shelf	170-190	35-45
Apple Yeast Tray Cake	Conventional 	3	Baking (universal) tray	150-170	65-75
	Convection 	2		150-170	70-80
	Convection 	1 + 4	Baking (universal) tray + Universal (deep) tray	150-170	75-85

FROZEN READY-MEAL

Food Item	Mode		Shelf level	Accessory	Temp. (°C)	Time (min.)
Frozen pizza (300-1000 g)	Convection		2	Wire shelf	200-220	15-25
Frozen oven chips (300-700 g)	Convection		2	Baking (universal) tray	180-200	20-30
Frozen croquettes (500-1000 g)	Convection		2	Baking (universal) tray	180-200	25-35
Frozen oven camembert (2 – 4 each 75 g) No preheat necessary	Eco Grill		3	Wire shelf	200	10-12
Frozen baguettes with topping (Tomato-mozzarella or Ham & cheese)	Eco Grill		3	Wire tray insert + Baking (universal) tray	200	15-20
Frozen fish fingers (300-700 g) No preheat necessary	Eco Grill		3	Wire tray insert + Baking (universal) tray	200	15-25
Frozen fish burger (300-600 g) No preheat necessary	Eco Grill		3	Baking (universal) tray	180-200	20-35
Frozen lasagne (500-1000 g)	Conventional		3	Wire shelf	180-200	40-50

automatic cooking

With automatic cooking function, you can select desired auto programmes for cooking, roasting and baking.

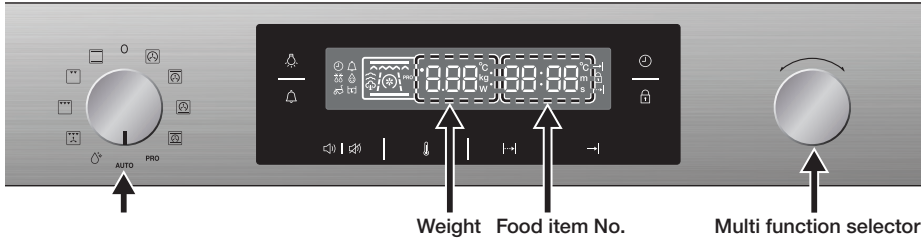

1. Turn the mode selector to Auto cook mode.
2. Turn the multi function selector to choose the desired Food item No. and wait for 4-5 seconds.
3. Turn the multi function selector to choose the desired weight and wait for 4-5 seconds.
4. After 4-5 seconds, Auto cook programmes will start automatically.

AUTO COOK PROGRAMMES

The following table presents 25 Auto Programmes for Cooking, Roasting and Baking. It contains its quantities, weight ranges and appropriate recommendations. Cooking modes and times have been pre-programmed for your convenience. You can refer to these guidelines for cooking. Always insert food in cold oven.

No	Food item	Weight/kg	Accessory	Shelf level	Recommendation
A:01	Frozen pizza	1. 0.3 - 0.6 2. 0.7 - 1.0	Wire shelf	2	Put frozen Pizza in the centre of Wire shelf. We recommend 0.3-0.6 kg setting for thin pizzas, 0.7-1.0 kg for pizzas with thick topping.
A:02	Frozen oven chips	1. 0.3 - 0.5 2. 0.5 - 0.7	Baking tray	2	Distribute frozen Oven Chips on baking tray. The first setting is recommended for thin French fries, the second setting is recommended for thick oven chips. Use baking paper. We recommend to turn over after 2/3 of cooking time.
A:03	Frozen croquettes	1. 0.3 - 0.6 2. 0.7 - 1.0	Baking tray	2	Put frozen potato croquettes evenly on baking tray. We recommend to turnover after 2/3 of cooking time.
A:04	Homemade lasagne	1. 0.3 - 0.5 2. 0.8 - 1.0	Wire shelf	3	Use ovenproof glassware. Put chilled or homemade lasagne in the middle of oven on wire rack.
A:05	Beef steaks	1. 0.3 - 0.6 2. 0.6 - 0.8	Wire shelf Universal tray	4 3	Put 2-6 beef steaks side by side evenly on Wire shelf. The first setting is for thin steaks, the second setting is for thick steaks. Turn over after beep sounds.

No	Food item	Weight/kg	Accessory	Shelf level	Recommendation
A:06	Roast beef	1. 0.6 - 0.8 2. 0.9 - 1.1 3. 1.2 - 1.4	Wire shelf Universal tray	2 1	Marinate Roast Beef and put on Wire shelf. Add 1 cup of water into Universal tray. Turn over after beep sounds. After cooking wrap in aluminium foil and let stand for 5-10 min.
A:07	Roast pork	1. 0.6 - 0.8 2. 0.9 - 1.1	Wire shelf Universal tray	2 1	Put marinated roast pork on Wire shelf. Turn over, as soon as the oven beeps
A:08	Lamb chops	1. 0.3 - 0.4 2. 0.5 - 0.6	Wire shelf Universal tray	4 3	Marinate lamb chops. Put lamb chops on Wire shelf. Turn over, as soon as the oven beeps. The first setting is for thin chops, the second setting is for thick chops.
A:09	Chicken pieces	1. 0.5 - 0.7 2. 1.0 - 1.2	Wire shelf Universal tray	4 3	Brush chicken pieces with oil and spices. Put chicken pieces side by side on the Wire shelf.
A:10	Roast chicken	1. 0.8 - 1.0 2. 1.1 - 1.3	Wire shelf Universal tray	2 1	Brush chilled chicken with oil and spices and put breast-side-up on the Wire shelf.
A:11	Duck breast	1. 0.3 - 0.5 2. 0.6 - 0.8	Wire shelf Universal tray	4 3	Prepare duck breast, put on the Wire shelf with the fat-side up. First setting is for one duck breast, the second setting is for 2 thick duck breasts.
A:12	Roll of turkey	1. 0.6 - 0.8 2. 0.9 - 1.1	Wire shelf Universal tray	2 1	Put roll of turkey on the Wire shelf. Turn over, as soon as the oven beeps
A:13	Steamed fish	1. 0.2 - 0.4 2. 0.5 - 0.7 3. 0.8 - 1.0	Wire shelf	2	Put prepared fresh fish (e.g. trout, haddock, codfish) in a suitable sized ovenproof glassware with lid. Add liquid until bottom of dish is covered e.g. 3-4 tbsp. lemon juice, white wine or water and cover with lid. Put dish on Wire shelf. If you prefer roasted appearance, brush skin of fish with olive oil and do not cover.
A:14	Roast fish	1. 0.5 - 0.7 2. 0.8 - 1.0	Wire shelf Universal tray	4 3	Put fishes head to tail on the Wire shelf. First setting is for 2 fishes, the second setting is for 4 fishes. The programme is suitable for whole fishes, like trout, pikeperch or gilthead.
A:15	Salmon steaks	1. 0.3 - 0.4 2. 0.7 - 0.8	Wire shelf Universal tray	4 3	Put salmon steaks on the Wire shelf. Turn over, as soon as the oven beeps.
A:16	Oven potatoes	1. 0.4 - 0.6 2. 0.8 - 1.0	Baking tray	2	Rinse potatoes, cut potatoes into halves. Brush with olive oil, herbs and spices. Distribute on the baking tray evenly. The first setting is for small potatoes (each 100 g), the second setting is for large oven potatoes (each 200 g).
A:17	Roast vegetables	1. 0.4 - 0.6 2. 0.8 - 1.0	Universal tray	4	Put vegetables, such as sliced courgette, pieces of pepper, sliced aubergine, mushrooms and cherry tomatoes into Universal tray. Brush with a mixture of olive oil, herbs and spices.

No	Food item	Weight/kg	Accessory	Shelf level	Recommendation
A:18	Vegetable gratin	1. 0.4 - 0.6 2. 0.8 - 1.0	Wire shelf	2	Prepare vegetable gratin using an ovenproof round dish. Put dish on Wire shelf in the centre of oven.
A:19	Marble cake	1. 0.5 - 0.6 2. 0.7 - 0.8 3. 0.9 - 1.0	Wire shelf	2	Put dough into suitable sized deep round baking pan for bundt cake/ ring cake. This programme is suitable for batter such as marble cake, lemon cake and hazelnut cake.
A:20	Muffins	1. 0.5 - 0.6 2. 0.7 - 0.8	Wire shelf	2	Put mixture into a suitable sized buttered baking dish or tin for 12 muffins. Set dish on rack. 0.5 -0.6 kg weight range is recommended for muffins of each 45 g, 0.7-0.8 kg weight range is recommended for medium sized muffins of each 65 g.
A:21	White bread	1. 0.7 - 0.8	Wire shelf	2	This programme is suitable for bread mixtures using 500 g wheat flour. Follow instruction on package. Put yeast dough into rectangular baking dish. Brush top of dough with water. Cut length with a knife.
A:22	Wholemeal bread	1. 0.7 - 0.8	Wire shelf	2	This programme is suitable for bread mixtures using 500 g wheat and rye flour. Follow instruction on package. Put leaven (sour dough) into suitable rectangular baking dish. Brush top of dough with water. Cut length with a knife.
A:23	Bread rolls / Ciabatta	1. 0.2 - 0.4 2. 0.6 - 0.8	Baking tray	3	The first setting is suitable for dough used for small pieces such as bread rolls or fresh dough for croissants (4-8 pcs). Setting 2 is suitable for dough used for homemade ciabatta breads or baguettes (2-6 pcs). Use baking paper.
A:24	Homemade pizza	1. 0.2 - 0.6 2. 0.8 - 1.2	Baking tray	2	The first setting is suitable for Pizza Snacks (7-9 pcs). Setting 2 is suitable for one round or tray sized Pizza. The weight ranges are including topping such as sauce, vegetables, ham and cheese. If you prefer strong crust, we recommend to preheat oven with bottom heat plus convection mode for 5 min.
A:25	Yeast dough fermentation	1. 0.2 - 0.4 (pizza dough) 2. 0.4 - 0.6 (yeast dough) 3. 0.6 - 0.8 (bread dough)	Wire shelf	2	0.2-0.4 kg weight range setting is to prepare yeast dough for pizza, cake, or to proof bread dough. Put into a big round dish and cover with cling film. 0.4-0.6 kg setting is for bread dough like yeast dough or sour dough. 0.6-0.8 kg setting is for leaven bread. Knead dough manually, put into baking dish and cover with cling film.

cleaning and cares

STEAM CLEANING (DEPENDING ON MODEL)

If the oven is dirty, it must be cleaned and you can use the steam cleaning option. It helps you clean the inside of the oven more easily.

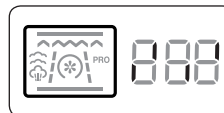

1. Remove all accessories from the oven before using the steam cleaning function.
2. Pour 400 ml (3/4 pint) of water onto the bottom of the oven and close the oven door.
3. Turn the mode selector to Δ^* . When you choose steam cleaning function, steam cleaning is automatically started after a few seconds.
4. When the display starts to blink with a signal, the steam cleaning is complete. Set the mode selector to Off to end the steam cleaning.
5. Clean the oven interior with a soft clean cloth and remove the remaining water on the bottom of the oven with a sponge.



INFORMATION

- If the oven interior is hot, the steam cleaning mode does not operate. Please cool down the oven before you operate it.



WARNING

- Take care when opening the door before the end of the steam cleaning procedure; the water on the bottom is hot.
- Never leave the residual water in the oven for a longer time, for example, over night.
- If the oven is heavily soiled, the procedure may be repeated after the oven has cooled.
- If the oven is heavily soiled with grease, for example, after roasting or grilling, it is recommend that you rub detergent into the stubborn soil before activating the oven cleaning function.
- Leave the oven door ajar after cleaning to allow the interior enamel surface to dry thoroughly.

CATALYTIC ENAMEL SURFACE (DEPENDING ON MODEL)

The removable parts are coated with a dark gray catalytic enamel this can become coated with oil and fat distributed by circulating air during convection heating. These deposits will burn off at oven temperatures of 200 °C and above.

1. Remove all accessories from the oven.
2. After cleaning all interior oven surfaces, set the oven to convection 250 °C for an hour.



INFORMATION

- The catalytic parts can be 1 side or 3 sides depending on model.

HAND CLEANING



WARNING: Make sure the oven and accessories are cool before cleaning.

Do not use abrasive cleaning agents, hard brushes, scouring pads or cloths, steel wool, knives or other abrasive materials.

Oven Interior

- For cleaning the interior of the oven, use a clean cloth and a mild cleaning agent or warm soapy water.
- Do not hand-clean the door seal.
- To avoid damaging the enameled oven surfaces, only use customary oven cleaners.
- To remove stubborn soil, use a special oven cleaner.

Oven exterior

For cleaning the exterior of the oven such as oven door, handle and display, use a clean cloth and a mild cleaning detergent or warm soapy water and dry with kitchen roll or a dry towel.

Especially grease and dirt can remain around handle or keys because of hot air coming from oven, so please clean handle and keys after you use the oven.

Accessories

Wash the accessories after every use and dry it with a tea towel.

If necessary, soak in warm soapy water for about 30 minutes for easier cleaning.

WATER COLLECTOR CLEANING (DEPENDING ON MODEL)

The water collector collects any excess moisture when oven is operating. Food residue can collect on the water collector. Clean the water collector regularly to protect your kitchen units from any damage after cooking.



WARNING: If you encounter a water leakage from the water collector after the cooking, please contact us at the service center.

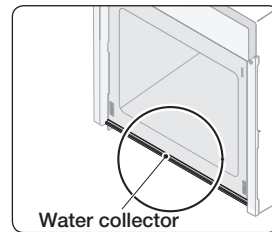

DETACHING THE SIDE RUNNERS (DEPENDING ON MODEL)

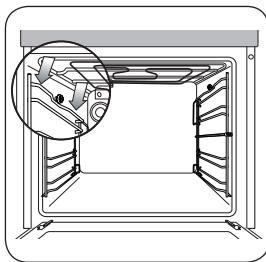

1. Press central part of the side runner top portion.

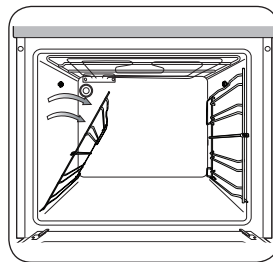

2. Rotate the side runner by approximately 45°.

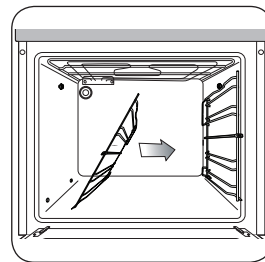

3. Pull and remove the side runner from bottom two holes. Repeat these steps in reverse order for attaching.



ATTACHING THE SIDE CATALYST (DEPENDING ON MODEL)

To install the side catalyst, the side runners should be removed. (Please refer to the "DETACHING THE SIDE RUNNERS")

1. Bring the side catalyst to interior's side surface. Adjust the oven interior's screw to side catalyst's hole and push the side catalyst.

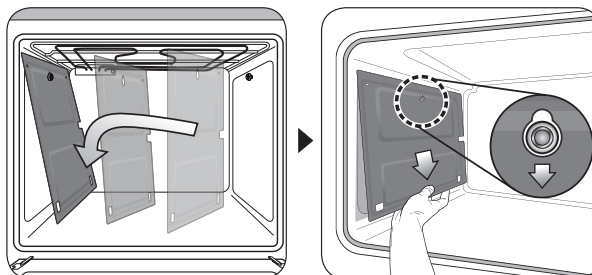

2. Check the side catalyst is hung like a picture. Attach the other side in the same way. Repeat above steps in reverse order for detaching.

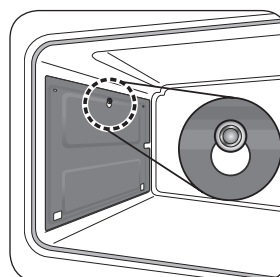

CLEANING THE CEILING (DEPENDING ON MODEL)

1. You can let down the grill heater to help when cleaning the ceiling of the oven. Remove the circular nut by turning it anti-clockwise while holding the grill heater.

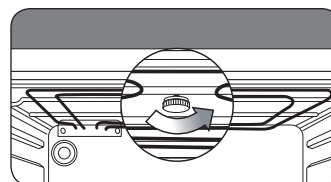

2. The front of the grill heater moves down and the grill heater can not be removed from the oven. Do not force the grill heater down, or it may become deformed.

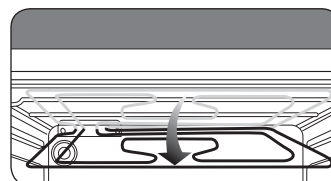

3. When cleaning has been done, lift the grill heater back to its original level and turn the circular nut clockwise.

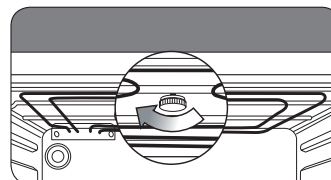



TROUBLESHOOTING

PROBLEM	SOLUTION
What should I do if the oven doesn't heat up?	<ul style="list-style-type: none"> The oven may not be switched on. Switch the oven on. Check to see if the required settings have been applied. A household fuse may have blown or a circuit breaker may have tripped. Replace the fuses or reset the circuit. If this happens repeatedly, call a qualified electrician.
What should I do if, even though the oven function and temperature have been set, the oven does not heat up?	<ul style="list-style-type: none"> Do not leave the oven door open while oven is cooking. If you don't leave the oven door open, there may be problems with the internal electrical connections. Call your local service centre.
What should I do if the oven light doesn't illuminate?	<ul style="list-style-type: none"> The oven light may have failed. Replace the oven light. If the oven light doesn't work after changing the oven light, call your local service centre.
What should I do if the cooling fan is running after the oven has been switched off?	<ul style="list-style-type: none"> After use, the cooling fan runs to protect your oven from the heat until the oven has cooled down. Call your local service centre if the cooling fan continues to run after the oven has cooled down.
What should I do if the all keys are not pressed?	<ul style="list-style-type: none"> Check if the child lock function is active or not. If the child lock function is not activated, call your local service centre.

INFORMATION CODES

All information codes are not from the fault of the oven. Please refer to below solution first, if the information codes still occur, please call your local SAMSUNG Customer Care Centre.

CODE	PROBLEM	SOLUTION
	Safety Shutoff Oven has continued operating at set temperature for prolonged time. <ul style="list-style-type: none"> Under 105 °C 16 hours From 105 °C to 240 °C 8 hours From 245 °C to Max 4 hours 	Turn oven off and remove food. As it is not the error of oven, please use the oven again after turning oven off.
	Key Error It occurs when the key is pressed and held for a period of time.	Clean the keys and check if there is water on the surface around key. Turn off the oven and try setting again. If it occurs again, call your local SAMSUNG Customer Care Centre.
	Safety Error An oven error may cause low performance and problems in safety.	Stop using the oven immediately and turn oven off. Call your local SAMSUNG Customer Care Centre.

1) ** refers to all numbers.











test dishes

According to standard EN 60350

1. Baking

The recommendations for baking refer to a preheated oven.

Always put trays the slanted side to the door front.

Type of food	Accessory	Shelf level	Cooking mode	Temp. (°C)	Time (min.)
Shortbread	Baking tray	3	Conventional 	160	20-30
		2	Convection 	150	25-35
	Baking tray + Universal tray	1 + 4	Convection 	150	25-35
Small cakes	Baking tray	3	Conventional 	160	15-25
		2	Convection 	150	25-35
	Baking tray + Universal tray	1 + 4	Convection 	150	30-40
Fatless sponge cake	Springform cake tin (Dark coated, ø 26 cm) on Wire shelf	2	Conventional 	160	25-35
		2	Convection 	160	35-45
Apple pie	Wire shelf + 2 Springform cake tins * (Dark coated, ø 20 cm)	1 Placed diagonally	Conventional 	180	70-90
	Baking (universal) tray + Wire shelf + 2 Springform cake tins ** (Dark coated, ø 20 cm)	1 + 3	Convection 	180	80-100

* Two cakes are arranged on the grid at the back left and at the front right.

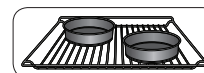

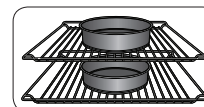

** Two cakes are arranged in the center on top of each other.



2. Grilling

Preheat the empty oven for 5 minutes using Large Grill function.

For Beef burgers, it is recommended to preheat the oven for 15 minutes.

Type of food	Accessory	Shelf level	Cooking mode	Temp. (°C)	Cooking (min.)
White bread toasts	Wire shelf	5	Large Grill 	270	1st 1-2 2nd 1-1½
Beef burgers (12 ea)	Wire tray insert + Universal tray (to catch drippings)	4	Large Grill 	270	1st 14-16 2nd 5-7



Производитель : Samsung Electronics Co., Ltd /
Самсунг Электроникс Ко., Лтд

Адрес производителя :
(Мэтан-донг) 129, Самсунг-ро, Йонгтонг-гу, Сувон-си,
Гйонгги-до, Корея, 443-742

Адрес мощностей производства :
20230 313 Моо 1, Сухафибан 8 Рoad, Срирача Индастри Парк,
Т. Бунг А. Срирача, Чонбури, Тайланд

Страна производства : Таиланд

Импортер в России :
ООО «Самсунг Электроникс Рус Компани»
Адрес: 125009, г. Москва, Россия, ул. Воздвиженка 10, 4 этаж

В СЛУЧАЕ ВОЗНИКНОВЕНИЯ ВОПРОСОВ ИЛИ КОММЕНТАРИЕВ

СТРАНА	ТЕЛЕФОН	ВЕБ-УЗЕЛ
RUSSIA	8-800-555-55-55	www.samsung.com/ru/support
GEORGIA	0-800-555-555	www.samsung.com/support
ARMENIA	0-800-05-555	
AZERBAIJAN	0-88-555-55-55	
KAZAKHSTAN	8-10-800-500-55-500(GSM: 7799, VIP care 7700)	
UZBEKISTAN	8-10-800-500-55-500	www.samsung.com/kz_ru/support
KYRGYZSTAN	8-10-800-500-55-500	
TADJIKISTAN	8-10-800-500-55-500	www.samsung.com/support
MONGOLIA	7-495-363-17-00	
BELARUS	810-800-500-55-500	
MOLDOVA	0-800-614-40	
UKRAINE	0-800-502-000	www.samsung.com/ua/support (Ukrainian) www.samsung.com/ua_ru/support (Russian)

DG68-00591B-01